

EC-TW4

Mini Table Type Motor Unit Type Side-mounted Motor Body Width 78 mm 24v Stepper Motor

Model Specification Items

Series	EC	Type	TW4	Lead	Stroke	Cable Length	Options
				H : 6mm M : 4mm L : 2mm	30:30mm 50:50mm	0: With terminal block type connector 1: 1m 2: 2m 3: 3m 4: 4m 5: 5m 6: 6m 7: 7m 8: 8m 9: 9m 10: 10m	Refer to Options below.

* Please refer to P.16 for more information about the model specification items.

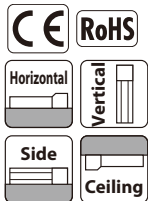

* Depending on the model, there may be some limitations to using the vertical, side, and ceiling mount positions. Please contact IAI for more information regarding mounting positions.

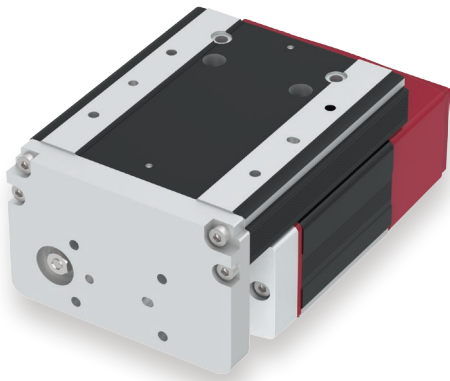

Table of Payload by Speed/Acceleration

Lead 6					Lead 4				
Orientation	Horizontal		Vertical		Orientation	Horizontal		Vertical	
	Acceleration (G)					Acceleration (G)			
Speed (mm/s)	0.3	0.5	0.3	0.5	Speed (mm/s)	0.3	0.5	0.3	0.5
0	2.5	2.5	1	1	0	4	4	1.5	1.5
300	2.5	2.5	1	1	200	4	4	1.5	1.5

Lead 2		
Orientation	Horizontal	Vertical
	Acceleration (G)	
Speed (mm/s)	0.3	0.3
0	8	2.5
100	8	2.5



(1) The maximum acceleration/deceleration is 0.3G for lead 2 and 0.5G for leads 4, 6.
 (2) When performing push-motion operation, refer to P.65.

Actuator Specifications

Lead and Payload					Stroke and Max Speed (Unit: mm/s)		
Model number	Lead (mm)	Max. payload		Max. push force (N)*	Lead (mm)	30 (mm)	50 (mm)
		Horizontal (kg)	Vertical (kg)				
EC-TW4H-①-②(-③)	6	2.5	1	30	6	300	
EC-TW4M-①-②(-③)	4	4	1.5	45	4	200	
EC-TW4L-①-②(-③)	2	8	2.5	90	2	100	

Legend: ① Stroke ② Cable Length ③ Option

*Speed limitation applies to push motion. See the manual or contact IAI.

① Stroke

① Stroke (mm)	EC-TW4
30	○
50	○

② Cable Length

Cable code	Cable length
0	No cable (with connector)
1~3	1~3m
4~5	4~5m
6~10	6~10m

③ Options

Name	Option code	Reference page
Brake	B	See P.59
Non-motor end specification	NM	See P.62
PNP specification	PN	See P.62
Battery-less Absolute Encoder specification	WA	See P.62
Wireless communication specification	WL	See P.62

Actuator Specifications

Item	Description
Drive system	Ball screw φ6mm, rolled C10
Positioning repeatability	±0.05mm
Table/frame	Material: Aluminum, black alumite treatment
Allowable static moment	Ma direction: 8.3N-m, Mb direction: 8.3N-m, Mc direction: 26.3N-m
Allowable dynamic moment (*)	Ma direction: 5.4N-m, Mb direction: 5.4N-m, Mc direction: 17.2N-m
Ambient operating temperature/humidity	0 to 40°C, 85% RH or less (Non-condensing)
Service life	5,000km or 50 million cycles

· Overhang load length guideline:
 Ma direction: 100mm or less in the table top direction, 50mm or less in the table tip direction
 Mb/Mc direction: 120mm or less
 (*) For reference rated life of 5,000km. The service life differs according to operation conditions and mounting status. Contact IAI to check the service life.

Dimensions

CAD drawings can be downloaded from our website.
www.intelligentactuator.com



*1 When the rod is returning to its home position, please be careful of interference from surrounding objects, as it will travel until it reaches the M.E.
M.E: Mechanical end S.E: Stroke end

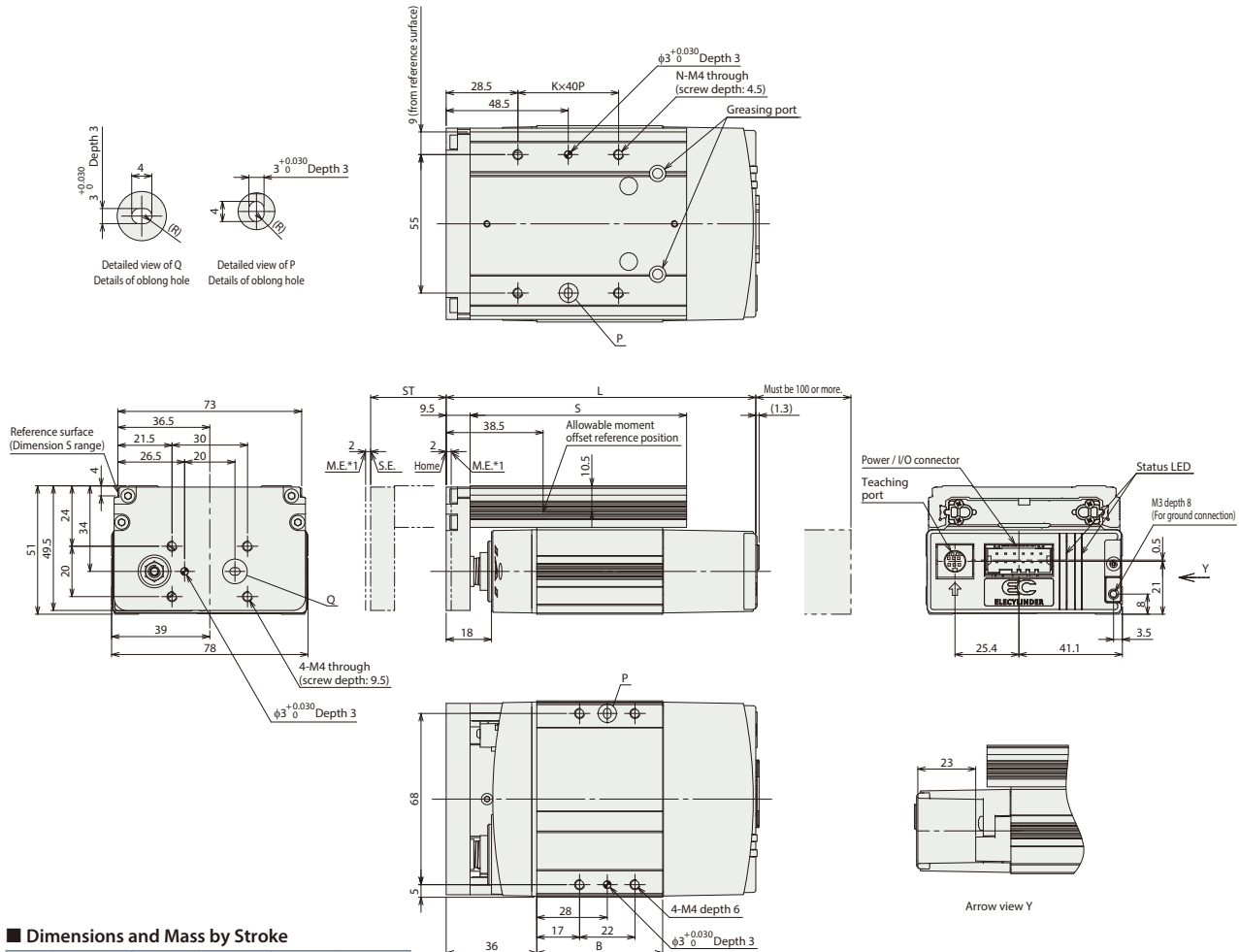

Dimensions and Mass by Stroke

Encoder Type	Incremental		Battery-less Absolute		
	Stroke	30	50	30	50
L	W/o Brake	123	143	143	143
	With Brake	153	153	173	173
B	W/o Brake	50	70	70	70
	With Brake	80	80	100	100
S		86	106	86	106
K		1	2	1	2
N		4	6	4	6
Weight (kg)	W/o Brake	0.8	0.9	0.8	0.9
	With Brake	0.9	1.0	1.0	1.0

Controller side Options/Accessories

Name	Touch Panel Teaching Pendant	PC software	24VDC power supply
External view			
Model	<input type="checkbox"/> TB-02 (for wired connection only) <input type="checkbox"/> TB-03 (for wired/wireless connection)	<input type="checkbox"/> RCM-101-MW (RS232 connection version) <input type="checkbox"/> RCM-101-USB (USB connection version)	<input type="checkbox"/> PS-241 (100V input) <input type="checkbox"/> PS-242 (200V input)
Overview	<ul style="list-style-type: none"> ● TB-02 A teaching pendant equipped with functions such as start point, end point, and AVD input, trial operation, and monitoring. ● TB-03 A data setter that supports wireless connection. The start point, end point and AVD can be input with wireless connection. 	Software for start point input, end point input and AVD input, trial operation, and monitoring using a PC. Both the RS232C version and USB version are available for PC connection.	A 24VDC power supply that can instantaneously output up to 17A. Input voltage 200VAC and 100VAC specifications are available.

* For system configurations using the above tools, refer to P.68.