

Standard Type **RCP6(S)**

Cleanroom Specification **RCP6(S)CR**

Dust/Splash-Proof Specification **RCP6(S)W**

Controller for ROBO Cylinder® **PCON-CB/CFB**

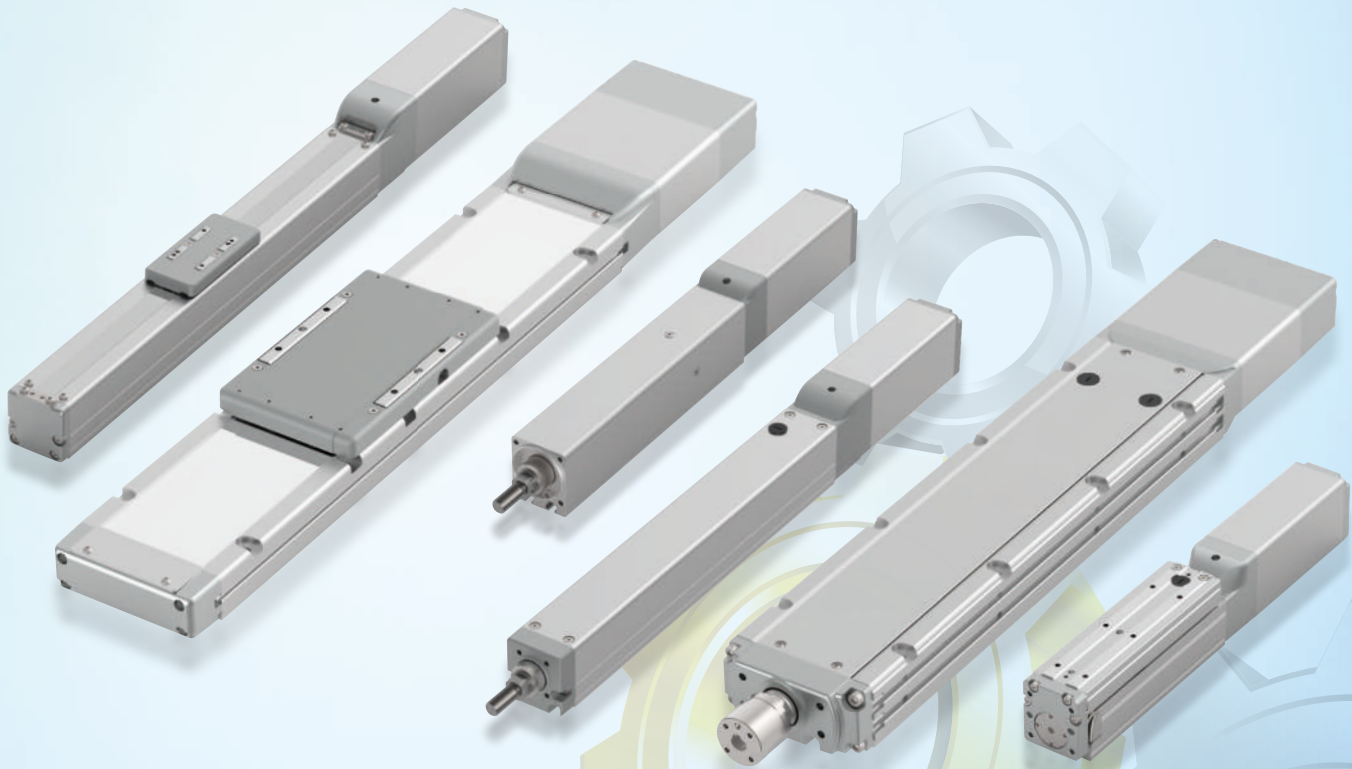

New Controller Series Additions



New Cleanroom Specification Series Additions

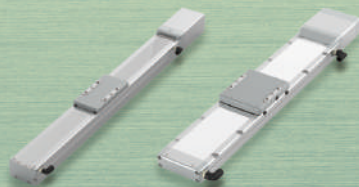

New Dust/Splash-Proof Specification Series Additions



IAI's Next Generation ROBO Cylinder®: RCP6

You Can Select the Product That Best Suits Your Needs from an Abundant Lineup of 156 Models*.

*Total by Types, Separate or Built-In Controller, and Specifications

1 Equipped with High-resolution Battery-less Absolute Encoder as Standard.

The advantages of an actuator with battery-less absolute encoder

No battery maintenance is required since there is no battery. Since home-return operation is not required at start up or after emergency stop or malfunction, this reduces your operation time, resulting in reduced production costs. Price is the same as the conventional incremental encoders.

The advantages of using an absolute encoder.

1. With an absolute encoder, home-return is not required.
2. No external home sensor is required since home-return is not necessary.
3. Removal of items being worked on is not necessary, even after an emergency stop.
4. The troublesome creation of home-return programs is not necessary even when stopping in the complex inside of a machine.

The advantages of battery-less

1. No battery maintenance required
2. No installation space for battery required

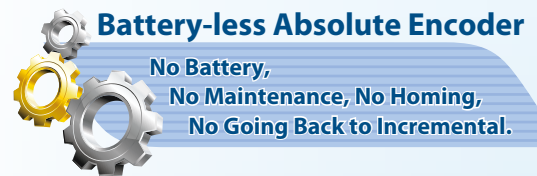

2 Improved Positioning Repeatability

With the improvement of the accurate processing technology of rolled ball screws and the thread grooves of nuts, a significantly higher precision compared to the previous ROBO Cylinder's positioning repeatability ($\pm 20\mu\text{m}$) has been achieved.

Standard specification $\pm 10\mu\text{m}$

High-precision specification $\pm 5\mu\text{m}$ (Available only for RCP6(S)-SA/WSA, RCP6(S)CR-SA/WSA)

* $1\mu\text{m}=0.001\text{mm}$

3 PowerCON® Compatible

Compatible with PowerCON® which is equipped with a high-output driver. The output of the stepper motor has increased by about 50% due to the use of PowerCON. Shortened cycle times were achieved through increased maximum speeds, which contributes to improved equipment productivity.

4 The Built-in Controller Type Is Available for All Models.

Standard/separate controller type or built-in controller type can be selected for all models.

The advantages of a built-in controller type.

- ▶ Smaller control panel.
- ▶ Simple wiring.
- ▶ Less maintenance parts necessary because wires are being shared.

By using the gateway unit and the hub unit(s), it is possible to reduce the size of the control panel and a number of cables.

*Please refer to P.8 for more information regarding the gateway unit and the hub unit.

Control Panel for Standard Controller

Control Panel for the RCP6S Built-in Controller Actuator

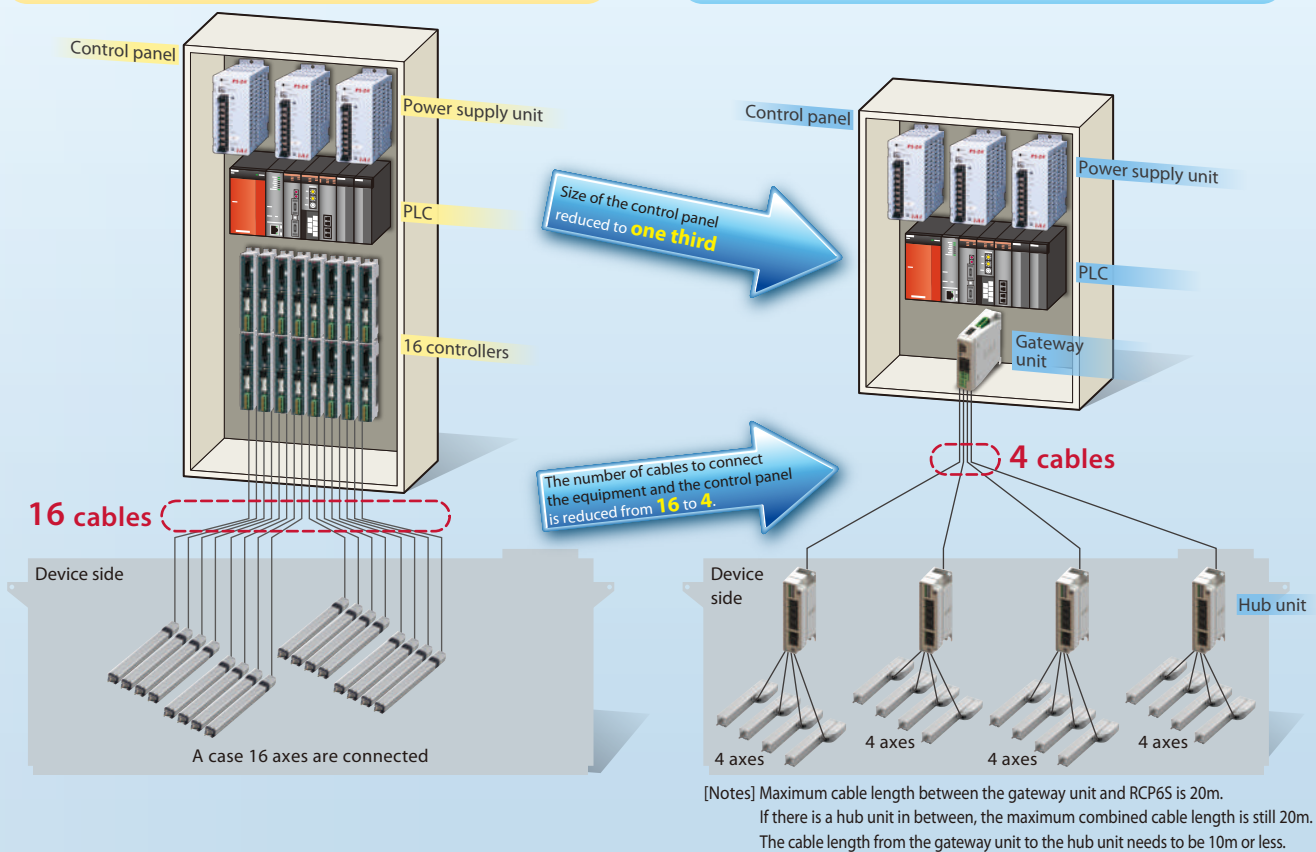

5 Gateway unit and hub unit connection capability RCP6S Gateway Controller

This controller can connect RCP, RCA, and RCD series actuators to an RCP6S gateway unit and hub unit. Mini ROBO Cylinders and gripper type actuators can be added to the RCP6S network. Please see P.282 for information on connectable models.

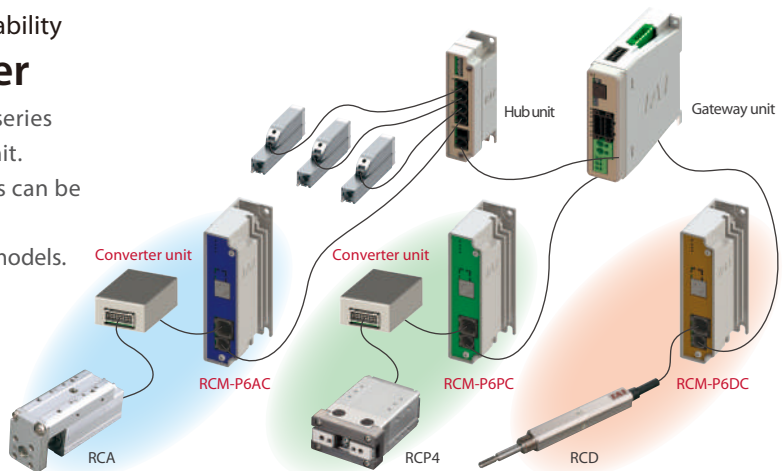

6 Cleanroom Specification Is Now Available

Clean Class 10 Clean Class 2.5

Cleanroom specification is now available. Eight slider types, including the wide slider, are available in total. Ideal for use in special environments such as cleanroom.

There are 2 standards that represent the cleanliness.

- 1. Fed.Std.209D Standard**
Displays the number of particles in 1ft³ with reference to particles of 0.5μm or more.
<Display method> Class 1, 10, 100, 1,000, 10,000, 100,000
- 2. JIS B9920 (ISO 14644-1) Standard**
The number of particles 0.1μm or larger in 1m³ is expressed in exponents when expressed in power of 10.



7 Dust/Splash-Proof Specification Is Now Available

IP 65

Dust-proof/splash-proof specification is now available. Twenty-four rod types or 48 models, including the Radial Cylinder and Wide Radial Cylinder, are available in total. Can be used for equipment that comes in contact with water.

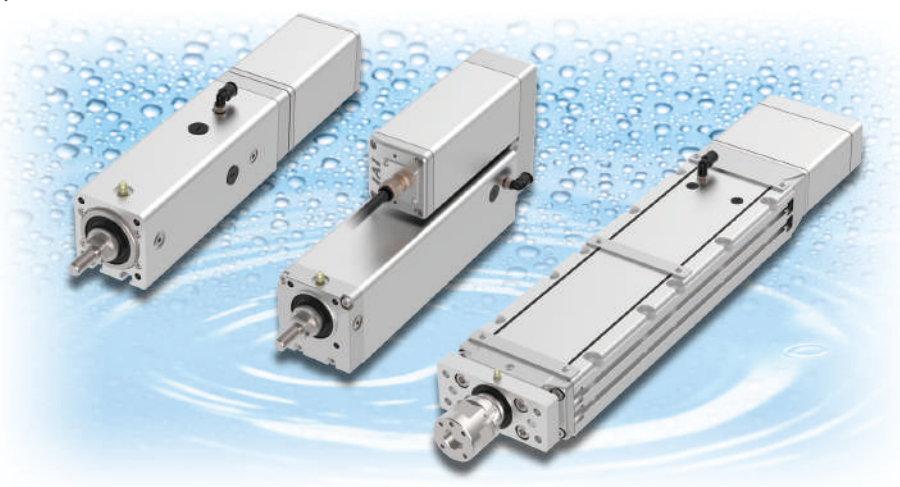

Protection Degree Display

IP

First Indicative Number
Protection against human bodies and solid foreign matter

Second Indicative Number
Protection against ingress of water

IP65	Solid foreign matter	(Summary) Dust-resistant type* Total protection of the interior from dust ingress.
	Water	(Summary) Protection from water jets.* No harmful effects from direct water jets coming from any direction.

* IEC 60529 / JIS C 0920

Table of Contents

Foreword

RCP6 Features	1
Table of Contents	4
Series Lineup and Features	5
Product Lineup	9
Model Specification Items	15

Slider Type

RCP6(S)-SA4C	21
Motor Coupled Specification RCP6(S)-SA6C	23
RCP6(S)-SA7C	25
RCP6(S)-SA8C	27

RCP6(S)-SA4R	29
Motor Side-mounted Specification RCP6(S)-SA6R	31
RCP6(S)-SA7R	33
RCP6(S)-SA8R	35

Wide Slider Type

RCP6(S)-WSA10C	37
Motor Coupled Specification RCP6(S)-WSA12C	39
RCP6(S)-WSA14C	41
RCP6(S)-WSA16C	43

RCP6(S)-WSA10R	45
Motor Side-mounted Specification RCP6(S)-WSA12R	47
RCP6(S)-WSA14R	49
RCP6(S)-WSA16R	51

Rod Type

RCP6(S)-RA4C	53
Motor Coupled Specification RCP6(S)-RA6C	55
RCP6(S)-RA7C	57
RCP6(S)-RA8C	59

RCP6(S)-RA4R	61
Motor Side-mounted Specification RCP6(S)-RA6R	63
RCP6(S)-RA7R	65
RCP6(S)-RA8R	67

Radial Cylinder®

RCP6(S)-RRA4C	69
Motor Coupled Specification RCP6(S)-RRA6C	71
RCP6(S)-RRA7C	73
RCP6(S)-RRA8C	75

RCP6(S)-RRA4R	77
Motor Side-mounted Specification RCP6(S)-RRA6R	79
RCP6(S)-RRA7R	81
RCP6(S)-RRA8R	83

Wide Radial Cylinder®

RCP6(S)-WRA10C	85
Motor Coupled Specification RCP6(S)-WRA12C	87
RCP6(S)-WRA14C	89
RCP6(S)-WRA16C	91

RCP6(S)-WRA10R	93
Motor Side-mounted Specification RCP6(S)-WRA12R	95
RCP6(S)-WRA14R	97
RCP6(S)-WRA16R	99

Table Type

RCP6(S)-TA4C	101
Motor Coupled Specification RCP6(S)-TA6C	105
RCP6(S)-TA7C	109

RCP6(S)-TA4R	113
Motor Side-mounted Specification RCP6(S)-TA6R	117
RCP6(S)-TA7R	121

<Cleanroom> Slider Type

RCP6(S)CR-SA4C	125
Motor Coupled Specification RCP6(S)CR-SA6C	127
RCP6(S)CR-SA7C	129
RCP6(S)CR-SA8C	131

<Cleanroom> Wide Slider Type

RCP6(S)CR-WSA10C	133
Motor Coupled Specification RCP6(S)CR-WSA12C	135
RCP6(S)CR-WSA14C	137
RCP6(S)CR-WSA16C	139

<Dust/Splash-Proof> Rod Type

RCP6(S)W-RA4C	141
Motor Coupled Specification RCP6(S)W-RA6C	143
RCP6(S)W-RA7C	145
RCP6(S)W-RA8C	147

RCP6(S)W-RA4R	149
Motor Side-mounted Specification RCP6(S)W-RA6R	151
RCP6(S)W-RA7R	153
RCP6(S)W-RA8R	155

Dust/Splash-Proof Radial Cylinder®

RCP6(S)W-RRA4C	157
Motor Coupled Specification RCP6(S)W-RRA6C	159
RCP6(S)W-RRA7C	161
RCP6(S)W-RRA8C	163

RCP6(S)W-RRA4R	165
Motor Side-mounted Specification RCP6(S)W-RRA6R	167
RCP6(S)W-RRA7R	169
RCP6(S)W-RRA8R	171

<Dust/Splash-Proof> Wide Radial Cylinder

RCP6(S)W-WRA10C	173
Motor Coupled Specification RCP6(S)W-WRA12C	175
RCP6(S)W-WRA14C	177
RCP6(S)W-WRA16C	179

RCP6(S)W-WRA10R	181
Motor Side-mounted Specification RCP6(S)W-WRA12R	183
RCP6(S)W-WRA14R	185
RCP6(S)W-WRA16R	187

Options

RCP6 Series Options	189
Selection Notes	196, 204

Reference Data

Correlation Diagrams of Push Force and Current Limit ...	205
Tables of Payload by Speed/Acceleration ...	207
Selection Guideline for Allowable Load Mass ...	243
Duty Cycle	247
Double Slider Selection Notes ...	248
Component Materials	249

Controller

PCON-CB/CFB	255
Controller Specifications ...	271
Gateway Unit	273
RCP6S Hub Unit	277
PLC Connection Unit	278
RCP6S Gateway Controller ...	279

Foreword
Slider Type
Wide Slider Type
Rod Type
Radial Cylinder
Wide Radial Cylinder
Table Type
Cleanroom Slider
Cleanroom Wide Slider
Dust/Splash-Proof Rod
Dust/Splash-Proof Radial Cylinder®
Dust/Splash-Proof Wide Radial Cylinder
Options
Reference Data
Controller

RCP6/RCP6S Series: Models and Features

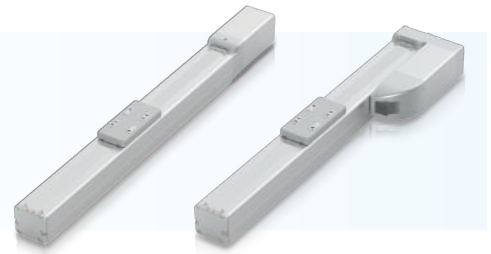

Slider Type: SA

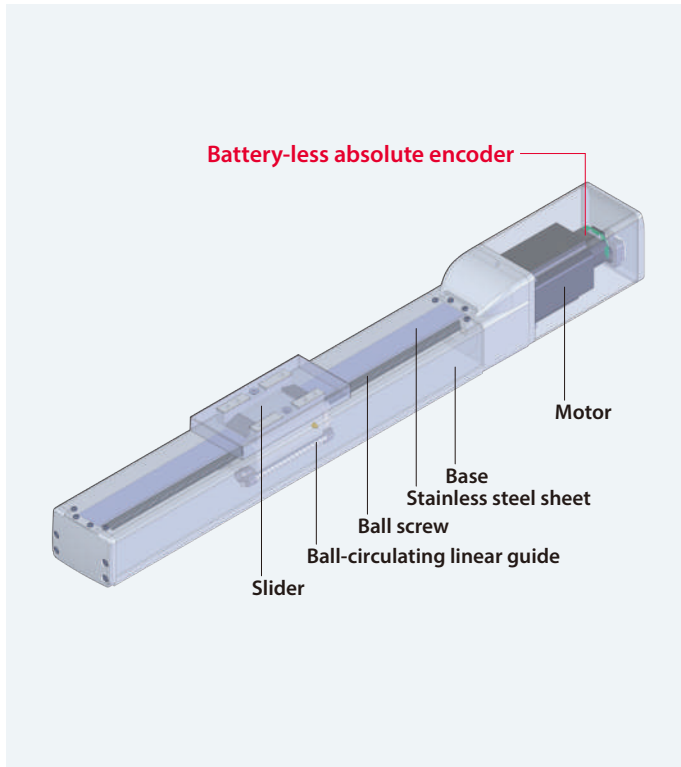

Features

- ▶ With a base integrated ball circulating linear guide, it will be able to deal with moments in the pitching (Ma), yawing (Mb), and rolling (Mc) directions.
- ▶ By combining multiple axes, two-dimensional and three-dimensional operations are possible.

Usage examples

- Switching from rod-less air cylinder
- Switching from self-made equipment with ballscrew, guide, and motor.
- Using as base and movable axes of the cartesian system.
- Work such as assembly, inspection, and measuring length that require high accuracy.

Wide Slider Type: WSA

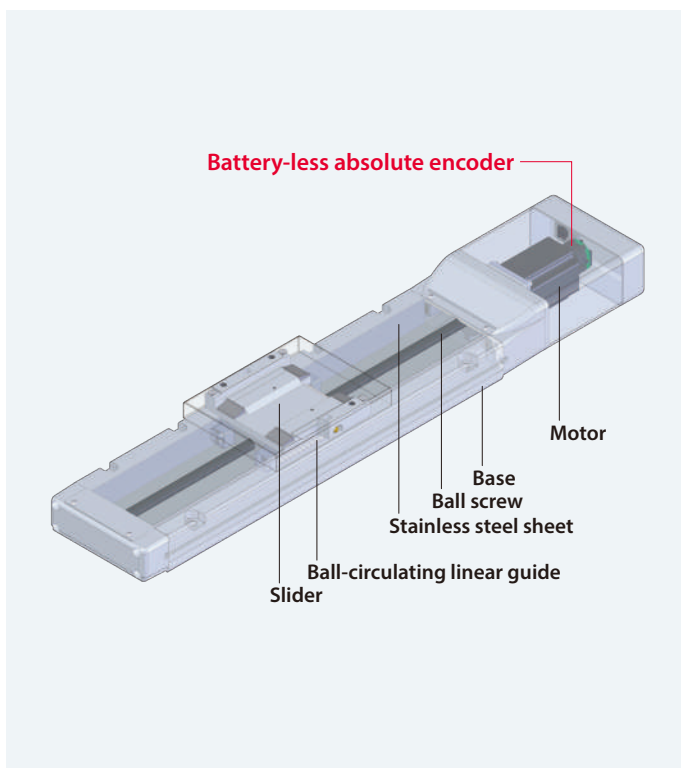

Features

- ▶ Perfect for the base axis of the cartesian system. With a built-in ball circulating linear guide inside its wide body, it will be able to deal with moments in the pitching (Ma), yawing (Mb), and rolling (Mc) directions.
- ▶ 2nd axis can be installed onto the wide slider type without removing its stainless steel sheet.
- ▶ By combining multiple axes, two-dimensional and three-dimensional operations are possible.

Usage examples

- Switching from rod-less air cylinder
- Switching from self-made equipment with ballscrew, guide, and motor.
- Work such as assembly, inspection, and measuring length that require high accuracy.

Rod Type: RA

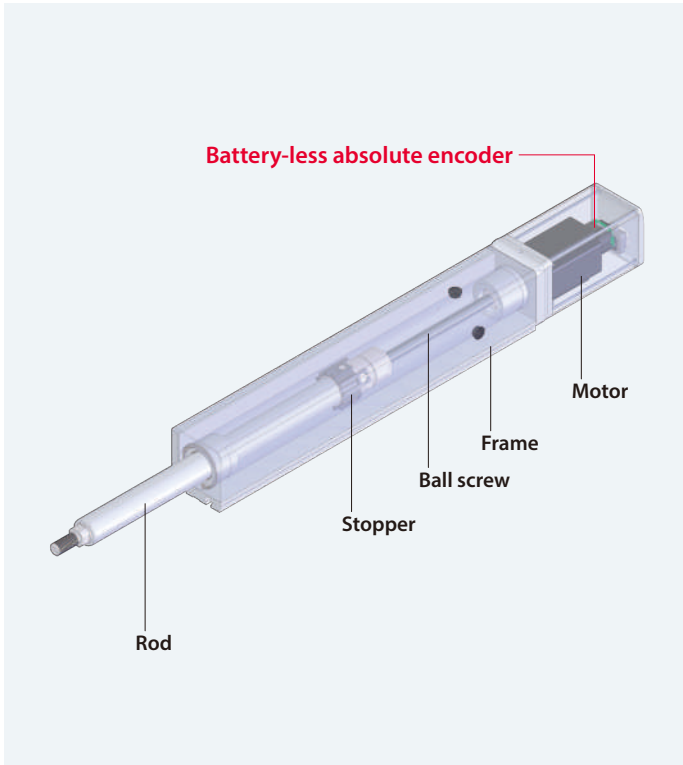

Features

- ▶ This is a type that does not build in a linear guide inside of the actuator. Of the RCP6 rod-types that resemble air cylinders, this is the least expensive model.

Usage examples

- Switching from rod type air cylinder
- Push force combined with a guide
- Inserting, press-fitting, or riveting a work
- Using as a lifter or a work piece unloader

Radial Cylinder: RRA

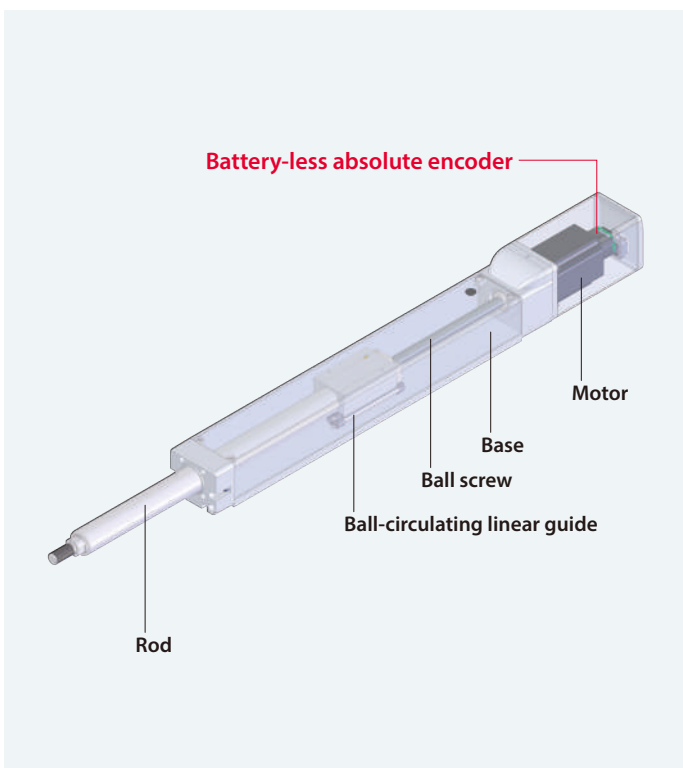

Features

- ▶ Since ball circulating linear guides are built in, it can take radial loads and moment loads. The vibration upon stopping can be suppressed and a long stroke of up to 700mm has become possible. In addition, product quality has significantly increased with a non-rotating rod precision of "0 degree" with a no load condition.
- ▶ The equipment will be compact since an external guide is unnecessary.

Usage examples

- Inserting, press-fitting, or riveting a work
- Using as a lifter or a work piece unloader
- Using as a movable vertical axis of the cartesian system
- Transferring or positioning a lightweight object

RCP6/RCP6S Series: Models and Features



Wide Radial Cylinder: **WRA**

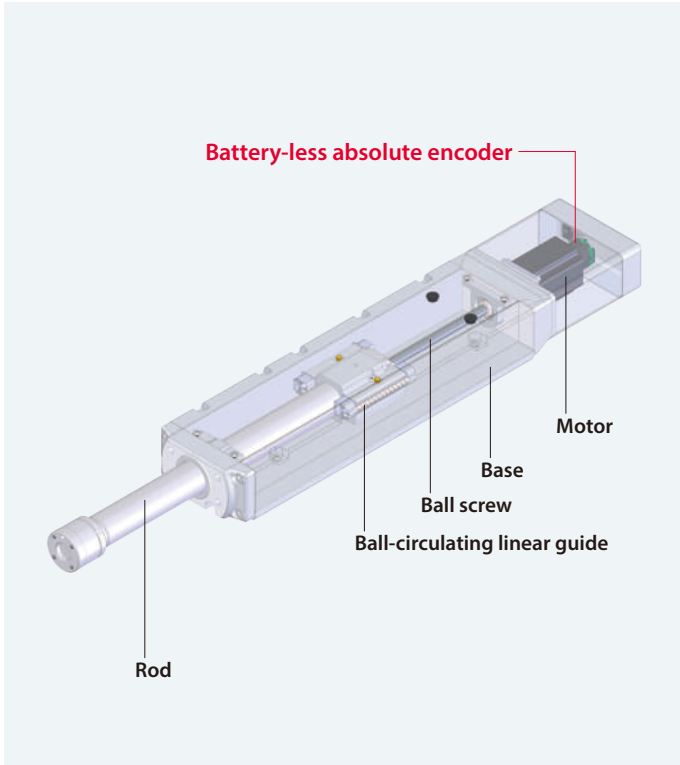

Features

- ▶ Due to a wide body and high-rigidity rod, it can deal with up to four times the allowable torque on rod tip compared to a standard radial cylinder. Due to a high dynamic allowable moment, it can be utilized for uses such as tightening screws and stirring that have large load torque.
- ▶ The equipment will be compact since an external guide is unnecessary.

Usage examples

- Inserting, press-fitting, or riveting a work
- Tightening a screw or stirring
- Using as a lifter or a work piece unloader
- Using as a movable vertical axis of the cartesian system
- Transferring or positioning a lightweight object
- Using as a base axis of the pick-and-place unit

Table Type: **TA**

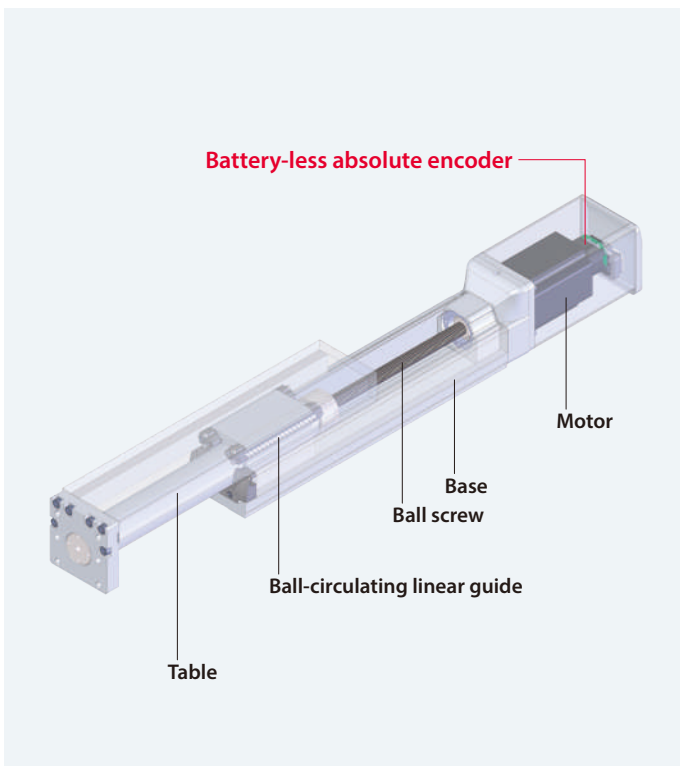

Features

- ▶ Work piece can be installed using the tapped mounting holes on the top surface of the table and the tip plate.
- ▶ With a built-in ball circulating linear guide in the table section, it will be able to deal with moments in the pitching (Ma), yawing (Mb), and rolling (Mc) directions.
- ▶ High-rigidity specification (double-block) can be selected as an option. With two guide blocks, the dynamic allowable moment increases.

Usage examples

- Switching from table type air cylinder
- Clamping tasks that pinch work from both sides
- Positioning tasks that hold work with the front side of the table
- A function for pushing works on a conveyor to the side
- Using as a movable vertical axis of the cartesian system

Built-in Controller Type: RCP6S

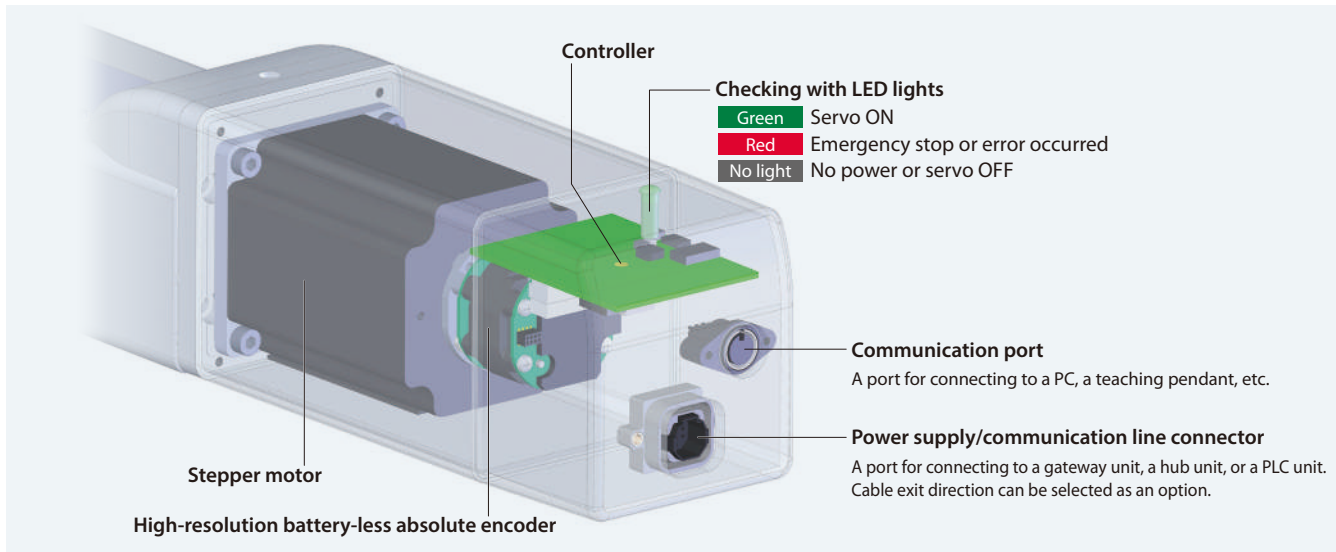

RCP6S Peripheral Equipment

*Gateway unit or PLC connection unit is required to operate the RCP6S.

1 Gateway Unit



► **Compatible field networks**
The gate unit can be used with the following 6 types of field networks.

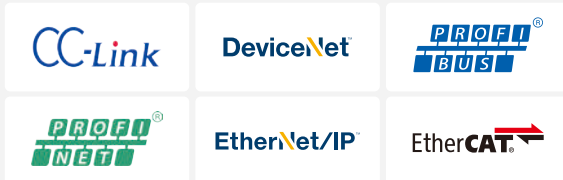

- 4 RCP6S' or 4 hub units can be connected to a gateway unit.
- Brake can be forcibly released by supplying power to the brake release input terminal of external power input for each channel. (In the case that the actuator is directly connected)

► The communication time when RCP6S is connected directly is 10ms, while it is 40ms when using the RCP6S with a hub unit. There will be no change in communication time when the number of connected actuators is increased.

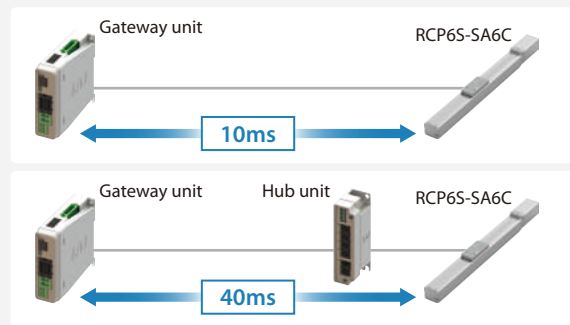

2 Hub Unit



- A hub unit is a signal distribution unit used by combining with a gateway unit.
- A gateway unit and a hub unit, or a hub unit and a RCP6 are each connected with a serial communication.
- A maximum of 4 RCP6S' can be connected.
- By operating the brake release switch, ON/OFF actions of the brake can be performed.

3 PLC Connection Unit



- A PLC connection unit is a unit to be moved with serial communication from a master controller or a PLC by combining it with RCP6S.
- A RCP6S and a PLC connection unit can be connected with a cable with connectors.

4 RCP6S Gateway Controller



- A controller for connecting RCP, RCA and RCD series units to a gateway unit or hub unit.
- Capable of connecting mini ROBO Cylinders and gripper type actuators within the RCP6S network.

Product Lineup

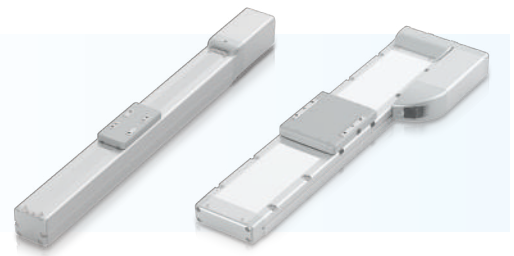

Slider Type: SA

Motor	Type	External View	Body Width (mm)	Lead (mm)	Positioning Repeatability (mm)	Stroke (mm)	Max. Speed (mm/s)		Reference Page
							Horizontal	Vertical	
Coupled Motor	SA4C		40mm	16	±0.01	50~500 (50mm increments)	1,260	7	P.21
				10			785	12	
				5			390	14	
				2.5			195	18	
	SA6C		58mm	20	±0.01	50~800 (50mm increments)	1,440 <1,280>	15	P.23
				12			900	28	
				6			450	32	
				3			225	40	
	SA7C		70mm	24	±0.01	50~800 (50mm increments)	1,200	37	P.25
				16			980 <840>	46	
				8			490	51	
				4			245 <210>	55	
SA8C		85mm	30	±0.01	50~1,100 (50mm increments)	1,200 <850>	28	P.27	
			20			1,000 <800>	60		
			10			500	70		
			5			250	80		
Side-mounted Motor	SA4R		40mm	16	±0.01	50~500 (50mm increments)	1260 <1120>	7	P.29
				10			785	12	
				5			390	14	
				2.5			195	18	
	SA6R		58mm	20	±0.01	50~800 (50mm increments)	1280 <1120>	15	P.31
				12			900 <800>	28	
				6			450	32	
				3			225	40	
	SA7R		70mm	24	±0.01	50~800 (50mm increments)	1,080	37	P.33
				16			840 <700>	46	
				8			420	51	
				4			210	55	
SA8R		85mm	30	±0.01	50~1,100 (50mm increments)	1,200 <850>	26	P.35	
			20			1,000 <800>	55		
			10			500 <450>	70		
			5			250	80		

Values in brackets < > are for when the maximum speed differs due to vertical use. Values in brackets [] are for high-precision specification.

Wide Slider Type: WSA

Motor	Type	External View	Body Width (mm)	Lead (mm)	Positioning Repeatability (mm)	Stroke (mm)	Max. Speed (mm/s)		Reference Page
							Horizontal	Vertical	
Coupled Motor	WSA10C		100mm	16	±0.01	50~500 (50mm increments)	840	4	P.37
				10			610	15	
				5			390 <350>	28	
				2.5			195 <175>	40	
	WSA12C		120mm	20	±0.01	50~800 (50mm increments)	800	12	P.39
				12			600	25	
				6			450 <400>	40	
				3			225	60	
	WSA14C		140mm	24	±0.01	50~800 (50mm increments)	700	25	P.41
				16			560	50	
				8			420 <350>	65	
				4			210 <175>	80	
WSA16C		160mm	20	±0.01	50~1,100 (50mm increments)	720	50	P.43	
			10			450 <240>	70		
			5			195 <170>	100		
							50		
Side-mounted Motor	WSA10R		100mm	16	±0.01	50~500 (50mm increments)	840	4	P.45
				10			610	15	
				5			390 <305>	28	
				2.5			195 <175>	40	
	WSA12R		120mm	20	±0.01	50~800 (50mm increments)	800	12	P.47
				12			600	25	
				6			450 <400>	40	
				3			225	60	
	WSA14R		140mm	24	±0.01	50~800 (50mm increments)	700	25	P.49
				16			560	50	
				8			420 <350>	65	
				4			175	80	
WSA16R		160mm	20	±0.01	50~1,100 (50mm increments)	600	30	P.51	
			10			365 <210>	70		
							15		
							45		

Values in brackets < > are for when the maximum speed differs due to vertical use. Values in brackets [] are for high-precision specification.

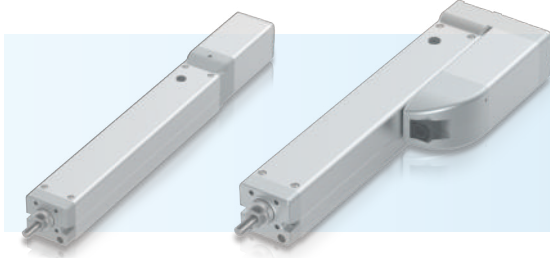

Rod Type: RA

*Push force can be achieved only during push mode and speed is limited below 20mm/s depending on the model. See manual for details.

Motor	Type	External View	Body Width (mm)	Lead (mm)	Positioning Repeatability (mm)	Stroke (mm)	Max. Speed (mm/s)	Max. Push Force (N)*	Max. Payload (kg)	Reference Page	
									Horizontal Vertical		
Coupled Motor	RA4C			16	±0.01	50~200 (50mm increments)	840	48	6	1.5	P.53
				10			700	77	15	2.5	
				5			350	155	28	5	
				2.5			175	310	40	10	
	RA6C			20	±0.01	50~300 (50mm increments)	800	56	6	1.5	P.55
				12			700	93	25	4	
				6			450	185	40	10	
				3			225	370	60	20	
	RA7C			24	±0.01	50~300 (50mm increments)	860 <640>	182	20	3	P.57
				16			700 <560>	273	50	8	
				8			420 <350>	547	60	18	
				4			210 <175>	1,094	80	28	
RA8C			20	±0.01	50~300 (50mm increments)	600 <450>	500	30	5	P.59	
			10			300 <250>	1,000	60	40		
			5			150	2,000	100	70		
Side-mounted Motor	RA4R			16	±0.01	50~200 (50mm increments)	840	48	5	1	P.61
				10			610	77	12	2.5	
				5			350	155	25	5	
				2.5			175	310	40	10	
	RA6R			20	±0.01	50~300 (50mm increments)	800	56	6	1.5	P.63
				12			700	93	25	4	
				6			450	185	40	10	
				3			225	370	60	20	
	RA7R			24	±0.01	50~300 (50mm increments)	860 <640>	182	20	3	P.65
				16			560	273	50	8	
				8			420 <350>	547	60	18	
				4			175	1,094	80	28	
RA8R			20	±0.01	50~300 (50mm increments)	400	500	30	5	P.67	
			10			200	1,000	60	40		
			5			100	2,000	100	70		

Values in brackets < > are for when the maximum speed differs due to vertical use.

Radial Cylinder: RRA

*Push force can be achieved only during push mode and speed is limited below 20mm/s depending on the model. See manual for details.

Motor	Type	External View	Body Width (mm)	Lead (mm)	Positioning Repeatability (mm)	Stroke (mm)	Max. Speed (mm/s)	Max. Push Force (N)*	Max. Payload (kg)	Reference Page	
									Horizontal Vertical		
Coupled Motor	RRA4C			16	±0.01	60~410 (50mm increments)	1,120	48	7	1.5	P.69
				10			700	77	18	3	
				5			350	155	28	6	
				2.5			175	310	40	10	
	RRA6C			20	±0.01	65~415 (50mm increments)	800	56	6	1.5	P.71
				12			700	93	25	4	
				6			450	185	40	10	
				3			225	370	60	20	
	RRA7C			24	±0.01	70~520 (50mm increments)	860 <640>	182	20	3	P.73
				16			700 <560>	273	50	8	
				8			420 <350>	547	60	18	
				4			210	1,094	80	28	
RRA8C			20	±0.01	50~700 (50mm increments)	600 <450>	500	30	5	P.75	
			10			300 <250>	1,000	60	40		
			5			150	2,000	100	70		
Side-mounted Motor	RRA4R			16	±0.01	60~410 (50mm increments)	840	48	5	1	P.77
				10			610	77	13	2.5	
				5			350	155	28	5	
				2.5			175	310	40	10	
	RRA6R			20	±0.01	65~415 (50mm increments)	800	56	6	1.5	P.79
				12			700	93	25	4	
				6			450	185	40	10	
				3			225	370	60	20	
	RRA7R			24	±0.01	70~520 (50mm increments)	860 <640>	182	20	3	P.81
				16			560	273	50	8	
				8			420 <350>	547	60	18	
				4			175	1,094	80	28	
RRA8R			20	±0.01	50~700 (50mm increments)	400	500	30	5	P.83	
			10			200	1,000	60	40		
			5			100	2,000	100	70		

Values in brackets < > are for when the maximum speed differs due to vertical use.

Product Lineup



Wide Radial Cylinder: WRA

*Push force can be achieved only during push mode and speed is limited below 20mm/s depending on the model. See manual for details.

Motor	Type	External View	Body Width (mm)	Lead (mm)	Positioning Repeatability (mm)	Stroke (mm)	Max. Speed (mm/s)	Max. Push Force (N)*	Max. Payload (kg)		Reference Page
									Horizontal	Vertical	
Coupled Motor	WRA10C		100mm	16	±0.01	50~500 (50mm increments)	700	48	4	-	P.85
				10			525	77	14.5	-	
				5			350 <260>	155	28	5	
				2.5			175	310	40	10	
				20			800	56	7.5	-	
				6			560	93	30	-	
	WRA12C		120mm	20	±0.01	50~500 (50mm increments)	400 <340>	185	55	7.5	P.87
				12			225 <200>	370	70	17.5	
				6			630	182	25	-	
				3			560	273	50	-	
				24			420 <210>	547	65	15	
				8			210 <130>	1,094	85	25	
WRA14C		140mm	20	±0.01	50~600 (50mm increments)	450	500	30	-	P.89	
			16			240 <200>	1,000	60	36.5		
			8			130 <100>	2,000	100	70		
			4			700	48	4	-		
			24			525	77	11.5	-		
			16			350 <260>	155	28	5		
WRA16C		160mm	5	±0.01	50~800 (50mm increments)	175 <150>	310	40	10	P.93	
			20			800	56	7.5	-		
			12			560	93	30	-		
			6			400 <280>	185	55	7.5		
			3			225 <200>	370	70	17.5		
			24			630	182	25	-		
Side-mounted Motor	WRA10R		100mm	16	±0.01	50~500 (50mm increments)	560	273	50	-	P.95
				10			350 <210>	547	65	15	
				5			175 <130>	1,094	85	25	
				2.5			420	500	30	-	
				20			240 <180>	1,000	60	34.5	
				12			120 <100>	2,000	100	63	
	WRA12R		120mm	20	±0.01	50~600 (50mm increments)	420	500	30	-	P.97
				16			350 <210>	547	65	15	
				8			175 <130>	1,094	85	25	
				4			420	500	30	-	
				24			240 <180>	1,000	60	34.5	
				16			120 <100>	2,000	100	63	
WRA14R		140mm	20	±0.01	50~800 (50mm increments)	420	500	30	-	P.99	
			16			240 <180>	1,000	60	34.5		
			8			120 <100>	2,000	100	63		
			4			700	48	4	-		
			24			525	77	11.5	-		
			16			350 <260>	155	28	5		
WRA16R		160mm	5	±0.01	50~800 (50mm increments)	175 <150>	310	40	10	P.99	
			20			800	56	7.5	-		
			12			560	93	30	-		
			6			400 <280>	185	55	7.5		
			3			225 <200>	370	70	17.5		
			24			630	182	25	-		

Values in brackets < > are for when the maximum speed differs due to vertical use.

Table Type: TA

Motor	Type	External View	Body Width (mm)	Lead (mm)	Positioning Repeatability (mm)	Stroke (mm)	Max. Speed (mm/s)	Max. Payload (kg)		Reference Page	
									Horizontal	Vertical	
Coupled Motor	TA4C		40mm	16*	±0.01	Single Block: 25~150 (25mm increments) Double Block: 40, 65, 90, 140, 190, 240	980 <700>	3[-]	1[-]	P.101 P.103	
				10			785 <700>	4[8]	2.5[2.5]		
				5			390	5[10]	5[5]		
				2.5			195	5[10]	10[10]		
				20*			1,120 <800>	5[-]	1[-]		
				12			800 [800<680>]	8[15]	3[3]		
	TA6C		58mm	6	±0.01	Single Block: 25~200 (25mm increments) Double Block: 45, 70, 95, 120~320 (50mm increments)	400	10[20]	6[6]	P.105 P.107	
				3			200	10[20]	12[12]		
				24*			1,080 <860>	10[-]	3[-]		
				16			700 <560>	12[25]	7[7]		
				8			420 <350>	15[30]	16[16]		
				4			210	15[30]	20[24]		
Side-mounted Motor	TA4R		40mm	16*	±0.01	Single Block: 25~150 (25mm increments) Double Block: 40, 65, 90, 140, 190, 240	980 <700>	3[-]	1[-]	P.113 P.115	
				10			785 <700> [700<525>]	4[8]	2.5[2.5]		
				5			390	5[10]	5[5]		
				2.5			195	5[10]	10[10]		
				20*			1,120 <800>	5[-]	1[-]		
				12			800 <680>	8[15]	3[3]		
	TA6R		58mm	6	±0.01	Single Block: 25~200 (25mm increments) Double Block: 45, 70, 95, 120~320 (50mm increments)	400	10[20]	6[6]	P.117 P.119	
				3			200	10[20]	12[12]		
				24*			1,080 <860>	10[-]	3[-]		
				16			700 <560>	12[25]	7[7]		
				8			420 <350>	15[30]	16[16]		
				4			210	15[30]	20[24]		
TA7R		70mm	24*	±0.01	Single Block: 25~300 (25mm increments) Double Block: 40, 65, 90~390 (50mm increments)	1,080 <860>	10[-]	3[-]	P.121 P.123		
			16			700 <560>	12[25]	7[7]			
			8			420 <350>	15[30]	16[16]			
			4			210	15[30]	20[24]			

* Single Block (SB) specification only. Values in brackets < > are for when the maximum speed differs due to vertical use. Values in brackets [] are for the double-block specification.



Slider Type SA <Cleanroom Specification>

Motor	Type	External View	Body Width (mm)	Lead (mm)	Positioning Repeatability (mm)	Max Speed (mm/s)	Max. Payload (kg)		Cleanliness	Reference Page	
							Horizontal	Vertical			
Coupled Motor	SA4C		40mm	16	±0.01 [±0.005]	1,260	7	1.5	Class 10 (Fed.Std.209D Standard)	P.125	
				10		785	12	3			
				5		390	14	5.5			
				2.5		195	18	12			
	SA6C		58mm	20	±0.01 [±0.005]	1,440<1,280>	15	1		P.127	
				12		900	28	2.5			
				6		450	32	6			
	SA7C		70mm	24	±0.01 [±0.005]	1,200	37	3		Class 2.5 Equivalent (ISO14644-1 Standard)	P.129
				16		980<840>	46	8			
				8		490	51	16			
				4		245<210>	55	25			
	SA8C		85mm	30	±0.01 [±0.005]	1,200<850>	28	3		P.131	
				20		1,000<800>	60	4			
				10		500	70	25			
				5		250	80	55			

Values in brackets < > are for when the maximum speed differs for vertical use. Values in brackets [] are for High-Precision Specification.

Wide Slider Type WSA <Cleanroom Specification>

Motor	Type	External View	Body Width (mm)	Lead (mm)	Positioning Repeatability (mm)	Max Speed (mm/s)	Max. Payload (kg)		Cleanliness	Reference Page	
							Horizontal	Vertical			
Coupled Motor	WSA10C		100mm	16	±0.01 [±0.005]	840	4	-	Class 10 (Fed.Std.209D Standard)	P.133	
				10		610	15	-			
				5		390<350>	28	3			
				2.5		195<175>	40	10			
	WSA12C		120mm	20	±0.01 [±0.005]	800	12	-		P.135	
				12		600	25	-			
				6		450<400>	40	9			
	WSA14C		140mm	3	±0.01 [±0.005]	225	60	18		Class 2.5 Equivalent (ISO14644-1 Standard)	P.137
				24		700	25	-			
				16		560	50	-			
				8		420<350>	65	14			
	WSA16C		160mm	4	±0.01 [±0.005]	210<175>	80	26		P.139	
				20		720	50	-			
				10		450<240>	70	15			
				5		195<170>	100	50			

Values in brackets < > are for when the maximum speed differs for vertical use. Values in brackets [] are for High-Precision Specification.

Product Lineup

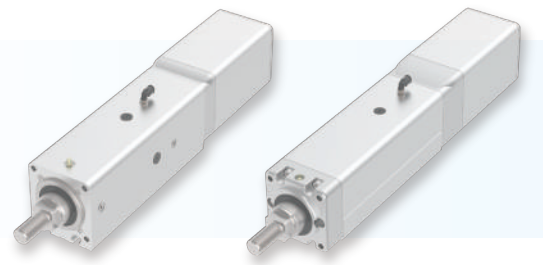

Rod Type **RA** <Dust/Splash-Proof Specification>

*Push force can be achieved only during push mode and speed is limited below 20mm/s depending on the model. See manual for details.

Motor	Type	External View	Body Width (mm)	Lead (mm)	Positioning Repeatability (mm)	Max speed (mm/s)		Max. Push Force (N)*	Max. Payload (kg)		Ingress Protection	Reference Page	
						Ambient Temperature Exceeding 5°C	Ambient Temperature 5°C or Below		Horizontal	Vertical			
Coupled Motor	RA4C		40mm	10	±0.01	525 <435>	435	77	11	2	IP65 (IEC 60529 Standard) (JIS C 0920 Standard)	P.141	
				5		350	260		155	23			4
				2.5		175 <150>	130		310	40			10
				12		630 <525>	525		93	25			4
				6		420 <370>	315		185	40			10
				3		210	105		370	60			20
	RA6C		58mm	16	±0.01	420	280	273	50	8		P.143	
				8		350 <280>	140		547	60			18
				4		140	105		1,094	80			28
				20		350 <330>	300		500	30			3
				10		200	170		1,000	60			35
				5		100	80		2,000	100			70
Side-mounted Motor	RA4R		40mm	10	±0.01	525 <435>	435	77	11	2	IP65 (IEC 60529 Standard) (JIS C 0920 Standard)	P.149	
				5		350	260		155	23			4
				2.5		175 <150>	130		310	40			10
				12		630 <525>	525		93	25			4
				6		420 <370>	315		185	40			10
				3		210	105		370	60			20
	RA6R		58mm	16	±0.01	420	280	273	50	8		P.151	
				8		350 <280>	140		547	60			18
				4		140	105		1,094	80			28
				20		350 <330>	300		500	30			3
				10		200	170		1,000	60			35
				5		100	80		2,000	100			70
RA7R		70mm	16	±0.01	420	280	273	50	8	P.153			
			8		350 <280>	140		547	60		18		
			4		140	105		1,094	80		28		
			20		350 <330>	300		500	30		3		
			10		200	170		1,000	60		35		
			5		100	80		2,000	100		70		
RA8R		85mm	20	±0.01	350 <330>	300	500	30	3	P.155			
			10		200	170		1,000	60		35		
			5		100	80		2,000	100		70		

Values in brackets < > are for when the maximum speed differs for vertical use.

Radial Cylinder® **RRA** <Dust/Splash-Proof Specification>

*Push force can be achieved only during push mode and speed is limited below 20mm/s depending on the model. See manual for details.

Motor	Type	External View	Body Width (mm)	Lead (mm)	Positioning Repeatability (mm)	Max speed (mm/s)		Max. Push Force (N)*	Max. Payload (kg)		Ingress Protection	Reference Page	
						Ambient Temperature Exceeding 5°C	Ambient Temperature 5°C or Below		Horizontal	Vertical			
Coupled Motor	RRA4C		45mm	10	±0.01	525 <435>	435	77	11	2	IP65 (IEC 60529 Standard) (JIS C 0920 Standard)	P.157	
				5		350	260		155	23			4
				2.5		175 <150>	105		310	40			10
				12		630 <525>	525		93	25			4
				6		420 <370>	315		185	40			10
				3		210	105		370	60			20
	RRA6C		65mm	16	±0.01	420	280	273	50	8		P.159	
				8		350 <280>	140		547	60			18
				4		140	105		1,094	80			28
				20		350 <330>	210		500	30			3
				10		200	130		1,000	60			35
				5		100	60		2,000	100			70
Side-mounted Motor	RRA4R		45mm	10	±0.01	525 <435>	435	77	11	2	IP65 (IEC 60529 Standard) (JIS C 0920 Standard)	P.165	
				5		350	260		155	23			4
				2.5		175 <150>	105		310	40			10
				12		630 <525>	525		93	25			4
				6		420 <370>	315		185	40			10
				3		210	105		370	60			20
	RRA6R		65mm	16	±0.01	420	280	273	50	8		P.167	
				8		350 <280>	140		547	60			18
				4		140	105		1,094	80			28
				20		350 <330>	210		500	30			3
				10		200	130		1,000	60			35
				5		100	60		2,000	100			70
RRA7R		78mm	16	±0.01	420	280	273	50	8	P.169			
			8		350 <280>	140		547	60		18		
			4		140	105		1,094	80		28		
			20		350 <330>	210		500	30		3		
			10		200	130		1,000	60		35		
			5		100	60		2,000	100		70		
RRA8R		85mm	20	±0.01	350 <330>	300	500	30	3	P.171			
			10		200	130		1,000	60		35		
			5		100	60		2,000	100		70		

Values in brackets < > are for when the maximum speed differs for vertical use.

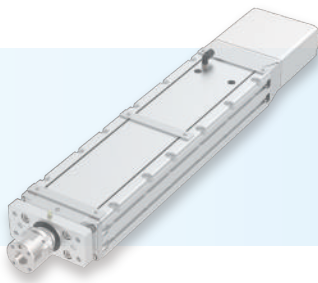

Wide Radial Cylinder **WRA** <Dust/Splash-Proof Specification>

*Push force can be achieved only during push mode and speed is limited below 20mm/s depending on the model. See manual for details.

Motor	Type	External View	Body Width (mm)	Lead (mm)	Positioning Repeatability (mm)	Max speed (mm/s)		Max. Push Force (N)*	Max. Payload (kg)		Ingress Protection	Reference Page			
						Ambient Temperature Exceeding 5°C	Ambient Temperature 5°C or Below		Horizontal	Vertical					
Coupled Motor	WRA10C		100mm	10	±0.01	525 <->	350	77	11.5	-	IP65 (IEC 60529 Standard) (JIS C 0920 Standard)	P.173			
				5		350 <215>	215						155	28	4
				2.5		175 <150>	65						310	40	10
	WRA12C		120mm	12	±0.01	560 <->	320	93	30	-		P.175			
				6		400 <220>	220						185	55	4
				3		225 <140>	80						370	70	14
	WRA14C		140mm	16	±0.01	420 <->	280	273	50	-		P.177			
				8		280 <210>	140						547	65	11.5
4				130		70	1,094				85		21.5		
WRA16C		160mm	20	±0.01	360 <->	240	500	30	-	P.179					
			10		220 <160>	120					1,000	60	30.5		
			5		110 <90>	80					2,000	100	59		
Side-mounted Motor	WRA10R		100mm	10	±0.01	525 <->	350	77	11.5	-	IP65 (IEC 60529 Standard) (JIS C 0920 Standard)	P.181			
				5		350 <215>	215						155	28	4
				2.5		175 <150>	65						310	40	10
	WRA12R		120mm	12	±0.01	560 <->	320	93	30	-		P.183			
				6		400 <220>	220						185	55	4
				3		225 <140>	80						370	70	14
	WRA14R		140mm	16	±0.01	420 <->	280	273	50	-		P.185			
				8		280 <210>	140						547	65	11.5
4				130		70	1,094				85		21.5		
WRA16R		160mm	20	±0.01	360 <->	240	500	30	-	P.187					
			10		220 <160>	120					1,000	60	30.5		
			5		110 <90>	80					2,000	100	59		

Values in brackets < > are for when the maximum speed differs for vertical use.

Model Specification Items

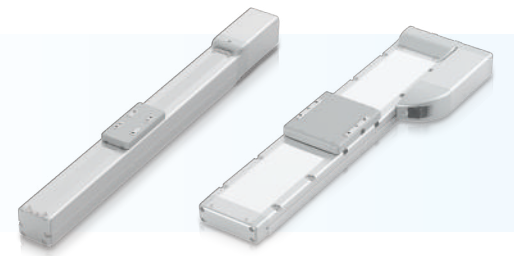

Slider Type: SA

Series	Type	Encoder Type	Motor Type	Ball Screw Lead	Stroke	Applicable Controller (RCP6)	I/O Type (RCP6S)	Cable Length	Options
RCP6 Separate controller RCP6S Built-in controller		WA Battery-less absolute	35P 35□ Stepper motor 42P 42□ Stepper motor 56P 56□ Stepper motor 56SP 56□ Stepper motor	2.5 2.5mm 3 3mm 4 4mm 5 5mm 6 6mm 8 8mm 10 10mm 12 12mm 16 16mm 20 20mm 24 24mm 30 30mm	50 50mm ? ? 1100 1,100mm (Can be set in 50mm increments)	P3 PCON-CB/CGB PCON-CYB/PLB/POB MCON-C/CG-LC/LCG MSEL-PC/PG P4 PCON-CFB/CGFB	SE SIO Type	N None P 1m S 3m M 5m X □ Specified length R □ Robot cable	B Brake CJT Cable exit direction (Top) CJR Cable exit direction (Right) CJL Cable exit direction (Left) CJO Cable exit direction (Outside) CJB Cable exit direction (Bottom) HPR High-precision specification ML Motor side-mounted to the left MR Motor side-mounted to the right NM Non-motor end specification SS Slider spacer SR Slider roller specification W Double slider specification
SA4C Body width 40mm Coupled motor type									
SA6C Body width 58mm Coupled motor type									
SA7C Body width 70mm Coupled motor type									
SA8C Body width 85mm Coupled motor type									
SA4R Body width 40mm Side-mounted motor type									
SA6R Body width 58mm Side-mounted motor type									
SA7R Body width 70mm Side-mounted motor type									
SA8R Body width 85mm Side-mounted motor type									

When RCP6 (separate controller type) is selected, please pick a code for the applicable controller, and when RCP6S (built-in controller type) is selected, please pick a code for the I/O type.

*The type of motor, ball screw lead, stroke, and options vary depending on the actuator type. Please refer to the pages of each type for details.

Wide Slider Type: WSA

Series	Type	Encoder Type	Motor Type	Ball Screw Lead	Stroke	Applicable Controller (RCP6)	I/O Type (RCP6S)	Cable Length	Options
RCP6 Separate controller RCP6S Built-in controller		WA Battery-less absolute	35P 35□ Stepper motor 42P 42□ Stepper motor 56P 56□ Stepper motor 56SP 56□ Stepper motor	2.5 2.5mm 3 3mm 4 4mm 5 5mm 6 6mm 8 8mm 10 10mm 12 12mm 16 16mm 20 20mm 24 24mm	50 50mm ? ? 1100 1,100mm (Can be set in 50mm increments)	P3 PCON-CB/CGB PCON-CYB/PLB/POB MCON-C/CG-LC/LCG MSEL-PC/PG P4 PCON-CFB/CGFB	SE SIO Type	N None P 1m S 3m M 5m X □ Specified length R □ Robot cable	B Brake CJT Cable exit direction (Top) CJR Cable exit direction (Right) CJL Cable exit direction (Left) CJO Cable exit direction (Outside) CJB Cable exit direction (Bottom) HPR High-precision specification ML Motor side-mounted to the left MR Motor side-mounted to the right NM Non-motor end specification SR Slider roller specification
WSA10C Body width 100mm Coupled motor type									
WSA12C Body width 120mm Coupled motor type									
WSA14C Body width 140mm Coupled motor type									
WSA16C Body width 160mm Coupled motor type									
WSA10R Body width 100mm Side-mounted motor type									
WSA12R Body width 120mm Side-mounted motor type									
WSA14R Body width 140mm Side-mounted motor type									
WSA16R Body width 160mm Side-mounted motor type									

When RCP6 (separate controller type) is selected, please pick a code for the applicable controller, and when RCP6S (built-in controller type) is selected, please pick a code for the I/O type.

*The type of motor, ball screw lead, stroke, and options vary depending on the actuator type. Please refer to the pages of each type for details.

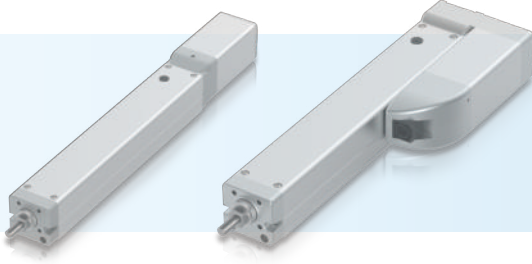

Rod Type: RA

RCP6 RCP6S — [] — **WA** — [] — [] — [] — [] / [] — [] — []

Series Type Encoder Type Motor Type Ball Screw Lead Stroke Applicable Controller (RCP6) I/O Type (RCP6S) Cable Length Options

RCP6 Separate controller		WA Battery-less absolute		50 50mm		SE SIO Type		N None	
RCP6S Built-in controller				300 300mm				P 1m	

(Can be set in 50mm increments)

35P 35□ Stepper motor				2.5 2.5mm		P3 PCON-CB/CGB PCON-CYB/PLB/POB MCON-C/CG-LC/LCG MSEL-PC/PG		S 3m	
42P 42□ Stepper motor				3 3mm		P4 PCON-CFB/CGFB		M 5m	
56P 56□ Stepper motor				4 4mm				X □ Specified length	
60P 60□ Stepper motor				5 5mm				R □ Robot cable	

When RCP6 (separate controller type) is selected, please pick a code for the applicable controller, and when RCP6S (built-in controller type) is selected, please pick a code for the I/O type.

RA4C Body width 40mm Coupled motor type				6 6mm				B Brake	
RA6C Body width 58mm Coupled motor type				8 8mm				CJT Cable exit direction (Top)	
RA7C Body width 70mm Coupled motor type				10 10mm				CJR Cable exit direction (Right)	
RA8C Body width 85mm Coupled motor type				12 12mm				CJL Cable exit direction (Left)	
RA4R Body width 40mm Side-mounted motor type				16 16mm				CJO Cable exit direction (Outside)	
RA6R Body width 58mm Side-mounted motor type				20 20mm				CJB Cable exit direction (Bottom)	
RA7R Body width 70mm Side-mounted motor type				24 24mm				FL Flange	
RA8R Body width 85mm Side-mounted motor type								FT Foot bracket	

ML Motor side-mounted to the left
MR Motor side-mounted to the right
MT Motor side-mounted to the top
NFA Tip adapter (Internal thread)
NM Non-motor end specification
NTB T-slot nut bar

*The type of motor, ball screw lead, stroke, and options vary depending on the actuator type. Please refer to the pages of each type for details.

Radial Cylinder: RRA

RCP6 RCP6S — [] — **WA** — [] — [] — [] — [] / [] — [] — []

Series Type Encoder Type Motor Type Ball Screw Lead Stroke Applicable Controller (RCP6) I/O Type (RCP6S) Cable Length Options

RCP6 Separate controller		WA Battery-less absolute		60 60mm		SE SIO Type		N None	
RCP6S Built-in controller				700 700mm				P 1m	

(Can be set in 50mm increments)

35P 35□ Stepper motor				2.5 2.5mm		P3 PCON-CB/CGB PCON-CYB/PLB/POB MCON-C/CG-LC/LCG MSEL-PC/PG		S 3m	
42P 42□ Stepper motor				3 3mm		P4 PCON-CFB/CGFB		M 5m	
56P 56□ Stepper motor				4 4mm				X □ Specified length	
60P 60□ Stepper motor				5 5mm				R □ Robot cable	

When RCP6 (separate controller type) is selected, please pick a code for the applicable controller, and when RCP6S (built-in controller type) is selected, please pick a code for the I/O type.

RRA4C Body width 40mm Coupled motor type				6 6mm				B Brake	
RRA6C Body width 58mm Coupled motor type				8 8mm				CJT Cable exit direction (Top)	
RRA7C Body width 70mm Coupled motor type				10 10mm				CJR Cable exit direction (Right)	
RRA8C Body width 85mm Coupled motor type				12 12mm				CJL Cable exit direction (Left)	
RRA4R Body width 40mm Side-mounted motor type				16 16mm				CJO Cable exit direction (Outside)	
RRA6R Body width 58mm Side-mounted motor type				20 20mm				CJB Cable exit direction (Bottom)	
RRA7R Body width 70mm Side-mounted motor type				24 24mm				FL Flange	
RRA8R Body width 85mm Side-mounted motor type								FFA Tip adapter (Flange)	

NFA Tip adapter (Internal thread)
KFA Tip adapter (Keyway)
ML Motor side-mounted to the left
MR Motor side-mounted to the right
NJ Knuckle joint
QR Clevis bracket
NM Non-motor end specification

*The type of motor, ball screw lead, stroke, and options vary depending on the actuator type. Please refer to the pages of each type for details.

Model Specification Items



Wide Radial Cylinder: WRA

Series	Type	Encoder Type	Motor Type	Ball Screw Lead	Stroke	Applicable Controller (RCP6)	I/O Type (RCP6S)	Cable Length	Options
RCP6 Separate controller RCP6S Built-in controller		WA Battery-less absolute	35P 35□ Stepper motor 42P 42□ Stepper motor 56P 56□ Stepper motor 60P 60□ Stepper motor	2.5 2.5mm 3 3mm 4 4mm 5 5mm 6 6mm 8 8mm 10 10mm 12 12mm 16 16mm 20 20mm 24 24mm	50 50mm 800 800mm (Can be set in 50mm increments)	P3 PCON-CB/CGB PCON-CYB/PLB/POB MCON-C/CG-LC/LCG MSEL-PC/PG P4 PCON-CFB/CGFB	SE SIO Type	N None P 1m S 3m M 5m X <input type="checkbox"/> Specified length R <input type="checkbox"/> Robot cable	B Brake CJT Cable exit direction (Top) CJR Cable exit direction (Right) CJL Cable exit direction (Left) CJO Cable exit direction (Outside) CJB Cable exit direction (Bottom) FL Flange ML Motor side-mounted to the left MR Motor side-mounted to the right NM Non-motor end specification NTBL T-slot nut bar (Left) NTBR T-slot nut bar (Right)
WRA10C Body width 100mm Coupled motor type									
WRA12C Body width 120mm Coupled motor type									
WRA14C Body width 140mm Coupled motor type									
WRA16C Body width 160mm Coupled motor type									
WRA10R Body width 100mm Side-mounted motor type									
WRA12R Body width 120mm Side-mounted motor type									
WRA14R Body width 140mm Side-mounted motor type									
WRA16R Body width 160mm Side-mounted motor type									

When RCP6 (separate controller type) is selected, please pick a code for the applicable controller, and when RCP6S (built-in controller type) is selected, please pick a code for the I/O type.

*The type of motor, ball screw lead, stroke, and options vary depending on the actuator type. Please refer to the pages of each type for details.

Table Type: TA

Series	Type	Encoder Type	Motor Type	Ball Screw Lead	Stroke	Applicable Controller (RCP6)	I/O Type (RCP6S)	Cable Length	Options
RCP6 Separate controller RCP6S Built-in controller		WA Battery-less absolute	35P 35□ Stepper motor 42P 42□ Stepper motor 56P 56□ Stepper motor	2.5 2.5mm 3 3mm 4 4mm 5 5mm 6 6mm 8 8mm 10 10mm 12 12mm 16 16mm 20 20mm 24 24mm	25 25mm 390 390mm	P3 PCON-CB/CGB PCON-CYB/PLB/POB MCON-C/CG-LC/LCG MSEL-PC/PG	SE SIO Type	N None P 1m S 3m M 5m X <input type="checkbox"/> Specified length R <input type="checkbox"/> Robot cable	B Brake CJT Cable exit direction (Top) CJR Cable exit direction (Right) CJL Cable exit direction (Left) CJO Cable exit direction (Outside) CJB Cable exit direction (Bottom) DB High-rigidity (Double-block guide) ML Motor side-mounted to the left MR Motor side-mounted to the right NM Non-motor end specification
TA4C Body width 40mm Coupled motor type									
TA6C Body width 58mm Coupled motor type									
TA7C Body width 70mm Coupled motor type									
TA4R Body width 40mm Side-mounted motor type									
TA6R Body width 58mm Side-mounted motor type									
TA7R Body width 70mm Side-mounted motor type									

When RCP6 (separate controller type) is selected, please pick a code for the applicable controller, and when RCP6S (built-in controller type) is selected, please pick a code for the I/O type.

*The type of motor, ball screw lead, stroke, and options vary depending on the actuator type. Please refer to the pages of each type for details.

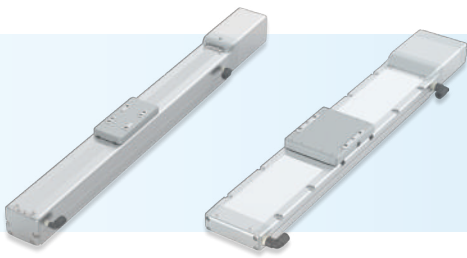

Slider Type: SA <Cleanroom Specification>

RCP6CR
RCP6SCR

Series Type Encoder Type Motor Type Ball Screw Lead Stroke Applicable Controller (RCP6CR) / I/O Type (RCP6SCR) Cable Length Options

RCP6CR	Separate controller	WA	Battery-less absolute	50	50mm	SE	SIO Type	N	None
RCP6SCR	Built-in controller								
SA4C	Body width 40mm Coupled motor type	35P	35□ Stepper motor	2.5	2.5mm	P3 PCON-CB/CGB PCON-CYB/PLB/POB MCON-C/CG-LC/LCG MSEL-PC/PG P4 PCON-CFB/CGFB	When RCP6CR (separate controller type) is selected, please pick a code for the applicable controller, and when RCP6SCR (built-in controller type) is selected, please pick a code for the I/O type.	S	3m
SA6C	Body width 58mm Coupled motor type	42P	42□ Stepper motor	3	3mm			X □	Specified length
SA7C	Body width 70mm Coupled motor type	56P	56□ Stepper motor	4	4mm			R □	Robot cable
SA8C	Body width 85mm Coupled motor type	56SP	56□ Stepper motor	5	5mm			B	Brake
				6	6mm			CJT	Cable exit direction (Top)
				8	8mm			CJR	Cable exit direction (Right)
				10	10mm			CJL	Cable exit direction (Left)
				12	12mm			CJO	Cable exit direction (Outside)
				16	16mm			CJB	Cable exit direction (Bottom)
				20	20mm			HPR	High-precision specification
				24	24mm	NM	Non-motor end specification		
				30	30mm	SS	Slider spacer		
						VR	Air suction joint in opposite position		
						W	Double slider specification		

*The type of motor, ball screw lead, stroke, and options vary depending on the actuator type. Please refer to the pages of each type for details.

Wide Slider Type: WSA <Cleanroom Specification>

RCP6CR
RCP6SCR

Series Type Encoder Type Motor Type Ball Screw Lead Stroke Applicable Controller (RCP6CR) / I/O Type (RCP6SCR) Cable Length Options

RCP6CR	Separate controller	WA	Battery-less absolute	50	50mm	SE	SIO Type	N	None
RCP6SCR	Built-in controller								
WSA10C	Body width 100mm Coupled motor type	35P	35□ Stepper motor	2.5	2.5mm	P3 PCON-CB/CGB PCON-CYB/PLB/POB MCON-C/CG-LC/LCG MSEL-PC/PG P4 PCON-CFB/CGFB	When RCP6CR (separate controller type) is selected, please pick a code for the applicable controller, and when RCP6SCR (built-in controller type) is selected, please pick a code for the I/O type.	S	3m
WSA12C	Body width 120mm Coupled motor type	42P	42□ Stepper motor	3	3mm			X □	Specified length
WSA14C	Body width 140mm Coupled motor type	56P	56□ Stepper motor	4	4mm			R □	Robot cable
WSA16C	Body width 160mm Coupled motor type	56SP	56□ Stepper motor	5	5mm			B	Brake
				6	6mm			CJT	Cable exit direction (Top)
				8	8mm			CJR	Cable exit direction (Right)
				10	10mm			CJL	Cable exit direction (Left)
				12	12mm			CJO	Cable exit direction (Outside)
				16	16mm			CJB	Cable exit direction (Bottom)
				20	20mm			HPR	High-precision specification
				24	24mm	NM	Non-motor end specification		
						VR	Air suction joint in opposite position		

*The type of motor, ball screw lead, stroke, and options vary depending on the actuator type. Please refer to the pages of each type for details.

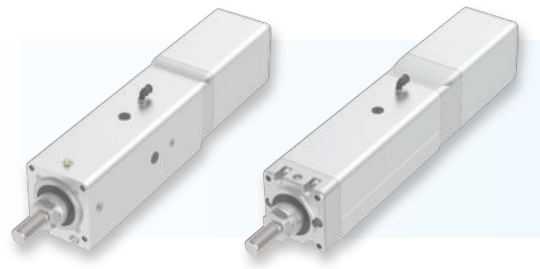

Model Specification Items

Rod Type: **RA** <Dust/Splash-Proof Specification>

RCP6W
RCP6SW

Series: **RCP6W** Separate controller, **RCP6SW** Built-in controller

Type: []

Encoder Type: **WA** Battery-less absolute

Motor Type: **35P** 35□ Stepper motor, **42P** 42□ Stepper motor, **56P** 56□ Stepper motor, **60P** 60□ Stepper motor

Ball Screw Lead: **2.5** 2.5mm, **3** 3mm, **4** 4mm, **5** 5mm, **6** 6mm, **8** 8mm, **10** 10mm, **12** 12mm, **16** 16mm, **20** 20mm

Stroke: **50** 50mm, **700** 700mm (Can be set in 50mm increments)

Applicable Controller (RCP6W): **P3** PCON-CB/CGB, PCON-CYB/PLB/POB, MCON-C/CG-LC/LCG, MSEL-PC/PG, **P4** PCON-CFB/CGFB, **P5** RCM-P6PC

I/O Type (RCP6SW): **SE** SIO Type

Cable Length: **N** None, **P** 1m, **S** 3m, **M** 5m, **X**□ Specified length, **R**□ Robot cable

Options: **FL** Flange, **FT** Foot bracket, **ML** Motor side-mounted to the left, **MR** Motor side-mounted to the right, **MT** Motor side-mounted on the top, **NFA** Tip adapter (Internal thread), **NM** Non-motor end specification, **NTB** T-slot nut bar

When RCP6W (separate controller type) is selected, please pick a code for the applicable controller, and when RCP6SW (built-in controller type) is selected, please pick a code for the I/O type.

* The type of motor, ball screw lead, stroke, and options vary depending on the actuator type. Please refer to the pages of each type for details.

Radial Cylinder: **RRA** <Dust/Splash-Proof Specification>

RCP6W
RCP6SW

Series: **RCP6W** Separate controller, **RCP6SW** Built-in controller

Type: []

Encoder Type: **WA** Battery-less absolute

Motor Type: **35P** 35□ Stepper motor, **42P** 42□ Stepper motor, **56P** 56□ Stepper motor, **60P** 60□ Stepper motor

Ball Screw Lead: **2.5** 2.5mm, **3** 3mm, **4** 4mm, **5** 5mm, **6** 6mm, **8** 8mm, **10** 10mm, **12** 12mm, **16** 16mm, **20** 20mm

Stroke: **50** 50mm, **700** 700mm (Can be set in 50mm increments)

Applicable Controller (RCP6W): **P3** PCON-CB/CGB, PCON-CYB/PLB/POB, MCON-C/CG-LC/LCG, MSEL-PC/PG, **P4** PCON-CFB/CGFB, **P5** RCM-P6PC

I/O Type (RCP6SW): **SE** SIO Type

Cable Length: **N** None, **P** 1m, **S** 3m, **M** 5m, **X**□ Specified length, **R**□ Robot cable

Options: **FL** Flange, **FT** Foot bracket, **FFA** Tip adapter (Flange), **KFA** Tip adapter (Keyway), **ML** Motor side-mounted to the left, **MR** Motor side-mounted to the right, **MT** Motor side-mounted on the top, **NFA** Tip adapter (Internal thread), **NM** Non-motor end specification, **NTB** T-slot nut bar

When RCP6W (separate controller type) is selected, please pick a code for the applicable controller, and when RCP6SW (built-in controller type) is selected, please pick a code for the I/O type.

* The type of motor, ball screw lead, stroke, and options vary depending on the actuator type. Please refer to the pages of each type for details.

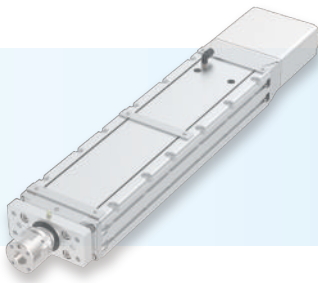

Wide Radial Cylinder: **WRA** <Dust/Splash-Proof Specification>

RCP6W
RCP6SW — [] — **WA** — [] — [] — [] — [] / [] — [] — []

Series Type Encoder Type Motor Type Ball Screw Lead Stroke Applicable Controller (RCP6W) I/O Type (RCP6SW) Cable Length Options

RCP6W	Separate controller	WA	Battery-less absolute		50 50mm	P3 PCON-CB/CGB PCON-CYB/PLB/POB MCON-C/CG-LC/LCG MSEL-PC/PG	SE SIO Type	N None	X <input type="checkbox"/> Specified length
RCP6SW	Built-in controller			800 800mm (Can be set in 50mm increments)	P4 PCON-CFB/CGFB				

WRA10C	Body width 100mm Coupled motor type
WRA12C	Body width 120mm Coupled motor type
WRA14C	Body width 140mm Coupled motor type
WRA16C	Body width 160mm Coupled motor type
WRA10R	Body width 100mm Side-mounted motor type
WRA12R	Body width 120mm Side-mounted motor type
WRA14R	Body width 140mm Side-mounted motor type
WRA16R	Body width 160mm Side-mounted motor type

35P	35□ Stepper motor
42P	42□ Stepper motor
56P	56□ Stepper motor
60P	60□ Stepper motor

2.5	2.5mm
3	3mm
4	4mm
5	5mm
6	6mm
8	8mm
10	10mm
12	12mm
16	16mm
20	20mm

When RCP6W (separate controller type) is selected, please pick a code for the applicable controller, and when RCP6SW (built-in controller type) is selected, please pick a code for the I/O type.

Not specified	Actuator cable length 2m
AC5	Actuator cable length 5m
AC10	Actuator cable length 10m
AC15	Actuator cable length 15m
B	Brake
CJT	Cable exit direction (Top)
CJR	Cable exit direction (Right)
CJL	Cable exit direction (Left)
CJO	Cable exit direction (Outside)
CJB	Cable exit direction (Bottom)
FL	Flange
ML	Motor side-mounted to the left
MR	Motor side-mounted to the right
NM	Non-motor end specification
NTBL	T-slot nut bar (Left)
NTBR	T-slot nut bar (Right)

*The type of motor, ball screw lead, stroke, and options vary depending on the actuator type. Please refer to the pages of each type for details.

RCP6(S)-SA4C



Model Specification Items

Series — Type — Encoder Type — Motor Type — Lead — Stroke — Applicable Controller/I/O Type — Cable Length — Options

RCP6: Separate Controller
RCP6S: Built-in Controller

WA: Battery-less Absolute

35P: Stepper Motor
35□ Size

16:16mm
10:10mm
5: 5mm
2.5:2.5mm

50: 50mm
500: 500mm (50mm increments)

[RCP6]
P3: PCON
MCON
MSEL
P5: RCM-P6PC
[RCP6S]
SE: SIO Type

N: None
P: 1m
S: 3m
M: 5m
X□□: Specified Length
R□□: Robot Cable

Please refer to the options table below.

* RCP6 does not include a controller. RCP6S includes a built-in controller.

* Please refer to P.15 for more information about the model specification items.

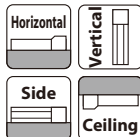

* Some limitations may apply to horizontal/side/ceiling mountings depending on the model. See page 204. Please contact IAI for more information.



Correlation Diagrams of Speed and Payload

(1) High-output enabled with PCON/MCON/MSEL connected.

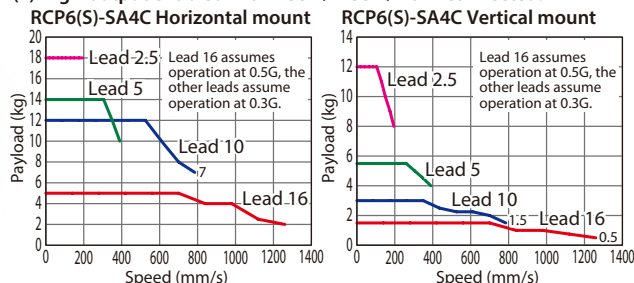

(2) High-output disabled with PCON/MCON connected.

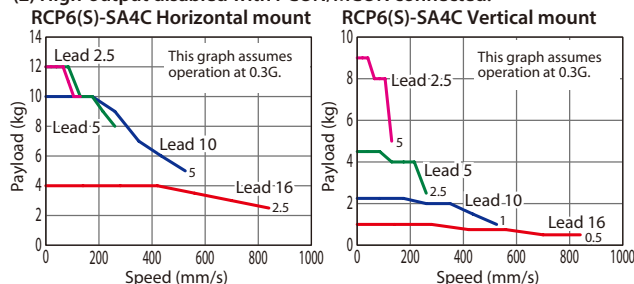

- The maximum acceleration/deceleration is 1G for horizontal, and 0.5G for vertical use.
- The actuator specification displays the payload's maximum value, but it will vary depending on the acceleration and speed. Please refer to the "Selection Guidelines" (Tables of Payload by Speed/Acceleration) on P.207 for more details.
- Please refer to P205 for performing push-motion operation.

Actuator Specifications

Lead and Payload

* Push force only available during push mode w / limited speed.

Model Number	Lead (mm)	Connected Controller	Max. Payload		Max. Push Force (N)*
			Horizontal (kg)	Vertical (kg)	
RCP6(S)-SA4C-WA-35P-16-①②③④	16	High-output Enabled	7	1.5	48
		High-output Disabled	4	1	
RCP6(S)-SA4C-WA-35P-10-①②③④	10	High-output Enabled	12	3	77
		High-output Disabled	10	2.25	
RCP6(S)-SA4C-WA-35P-5-①②③④	5	High-output Enabled	14	5.5	155
		High-output Disabled	12	4.5	
RCP6(S)-SA4C-WA-35P-2.5-①②③④	2.5	High-output Enabled	18	12	310
		High-output Disabled	12	9	

Legend: ① Stroke ② Applicable controller/I/O type ③ Cable length ④ Options

Stroke and Max. Speed

(Unit: mm/s)

Lead (mm)	Connected Controller	50~400 (Every 50mm)	450 (mm)	500 (mm)
	High-output Disabled	840		
10	High-output Enabled	785	675	555
	High-output Disabled	525		
5	High-output Enabled	390	330	275
	High-output Disabled	260		
2.5	High-output Enabled	195	165	135
	High-output Disabled	130		

① Stroke

Stroke (mm)	RCP6	RCP6S	Stroke (mm)	RCP6	RCP6S
50	○	○	300	○	○
100	○	○	350	○	○
150	○	○	400	○	○
200	○	○	450	○	○
250	○	○	500	○	○

④ Options

Name	Option Code	Reference Page
Brake	B	See P.189
Cable exit direction (Top)	CJT	See P.189
Cable exit direction (Right)	CJR	See P.189
Cable exit direction (Left)	CJL	See P.189
Cable exit direction (Bottom)	CJB	See P.189
Designated grease coating specification	G1/G3/G4	
High-Precision Specification (*1)	HPR	See P.192
Non-motor end specification	NM	See P.194
Slider roller specification	SR	See P.195
Double slider specification (*2)	W	See P.196

(*1) When the lead is 16, it cannot be selected. Double slider specification cannot be selected.

(*2) Some leads cannot be selected. (Please see P.248)

When selecting multiple options, please list them in alphabetical order. (e.g. B-CJB-NM)

③ Cable Length

Cable Type	Cable Code	RCP6		RCP6S
		P3	P5	SE
Standard	P (1m)	○	○	○
	S (3m)	○	○	○
	M (5m)	○	○	○
Specified Length	X06 (6m) ~X10 (10m)	○	○	○
	X11 (11m) ~X15 (15m)	○	○	○
	X16 (16m) ~X20 (20m)	○	○	○
		○	○	○
Robot Cable	R01 (1m) ~R03 (3m)	○	○	○
	R04 (4m) ~R05 (5m)	○	○	○
	R06 (6m) ~R10 (10m)	○	○	○
	R11 (11m) ~R15 (15m)	○	○	○
	R16 (16m) ~R20 (20m)	○	○	○
		○	○	○

* Please refer to P.267 and 283 for more information regarding the maintenance cables.

Actuator Specifications

Item	Description
Drive system	Ball screw φ8mm, rolled C10
Positioning repeatability (*1)	±0.01mm [±0.005mm]
Lost motion	0.1mm or less
Base	Material: Aluminum with white alumite treatment
Static allowable moment	Ma: 13.0N·m, Mb: 18.6N·m, Mc: 25.3N·m
Dynamic allowable moment (*2)	Ma: 5.0N·m, Mb: 7.1N·m, Mc: 9.7N·m
Ambient operating temp. & humidity	0~40°C, 85% RH or less (Non-condensing)

* Reference for overhang load length: Ma: 150mm or less, Mb, Mc: 150mm or less

(*1) Values in [] are for high-precision (for lead 2.5/5/10) specification.

(*2) Assumes a standard rated life of 5,000km. The service life will vary depending on operation and installation conditions.

Please refer to our website for more information regarding the directions of the allowable moment and overhang load length.



*1 When the slider is returning to its home position, please be careful of interference from surrounding objects, as it will travel until it reaches the M.E.
M.E: Mechanical end S.E: Stroke end

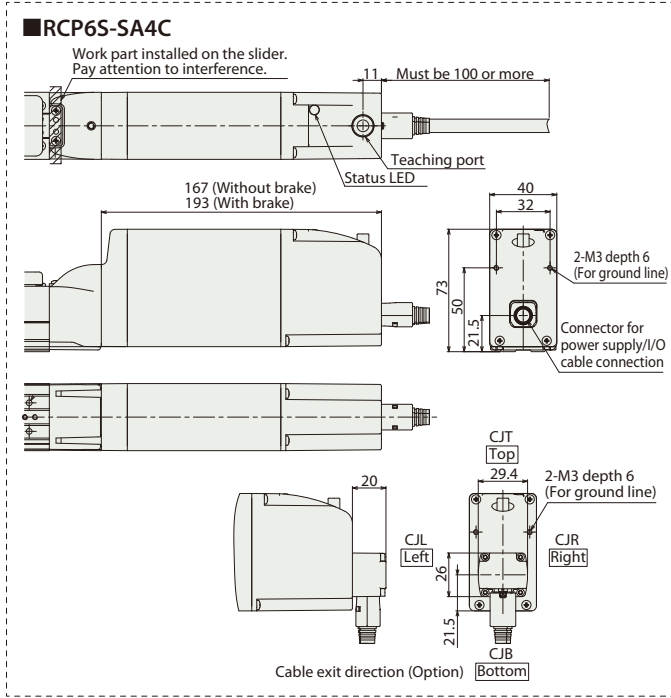
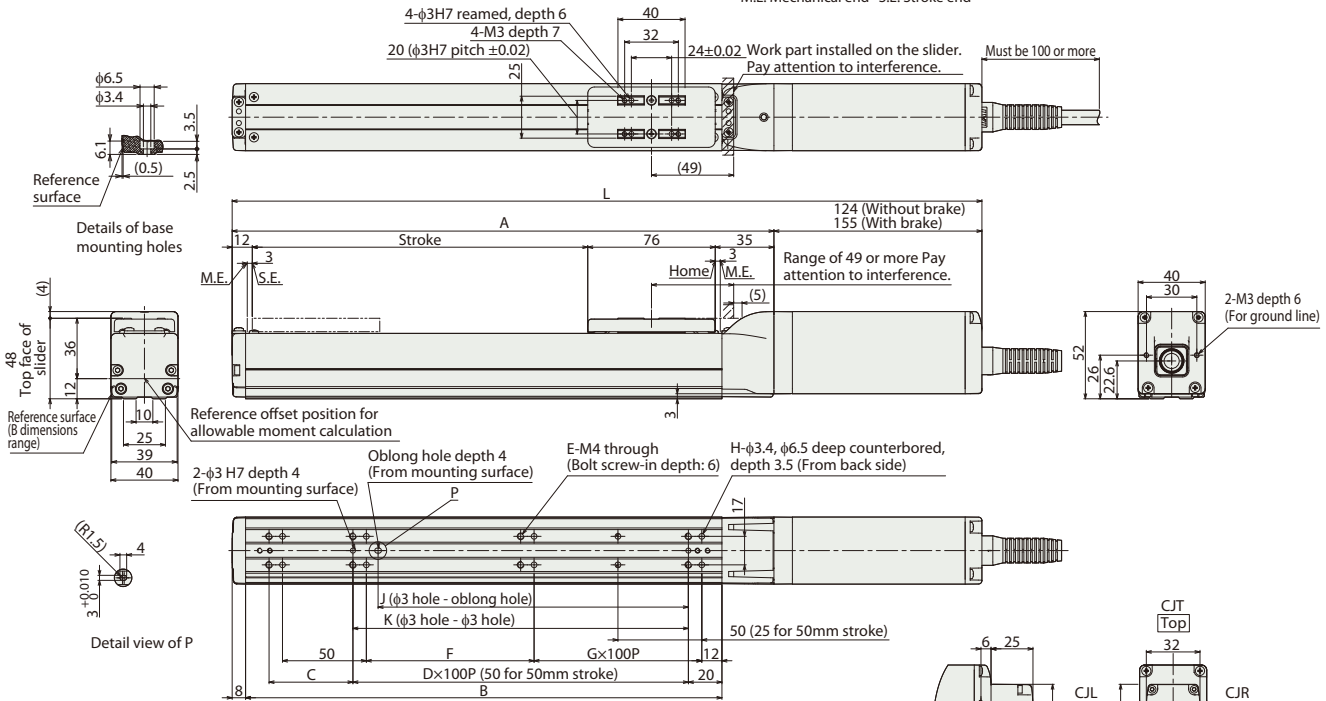

■ Dimensions and Mass by Stroke

		Stroke	50	100	150	200	250	300	350	400	450	500
L	RCP6	w/o brake	297	347	397	447	497	547	597	647	697	747
		w/brake	328	378	428	478	528	578	628	678	728	778
	RCP6S	w/o brake	340	390	440	490	540	590	640	690	740	790
		w/brake	366	416	466	516	566	616	666	716	766	816
A			173	223	273	323	373	423	473	523	573	623
B			134	184	234	284	334	384	434	484	534	584
C			50	50	100	50	100	50	100	50	100	50
D			-	1	1	2	2	3	3	4	4	5
E			6	6	6	8	8	10	10	12	12	14
F			50	100	50	100	50	100	50	100	50	100
G			0	0	1	1	2	2	3	3	4	4
H			8	8	10	10	12	12	14	14	16	16
J			35	85	85	185	185	285	285	385	385	485
K			50	100	100	200	200	300	300	400	400	500
Mass (kg)	RCP6	w/o brake	1.1	1.2	1.3	1.4	1.5	1.6	1.7	1.8	1.9	2.0
		w/brake	1.3	1.4	1.5	1.5	1.6	1.7	1.8	1.9	2.0	2.1
	RCP6S	w/o brake	1.3	1.4	1.5	1.6	1.7	1.8	1.9	2.0	2.1	2.2
		w/brake	1.5	1.6	1.6	1.7	1.8	1.9	2.0	2.1	2.2	2.3

② Applicable Controllers

The RCP6 series actuators can be operated by the controllers indicated below. Please select the type depending on your intended use. * Please refer to P.271 for more information about the built-in controller of RCP6S series.

Name	External view	Max. number of controlled axes	Input power	Control method				Maximum number of positioning points	Reference page
				Positioner	Pulse train	Program	Network * Option		
PCON-CYB/PLB/POB		1	DC24V	●	●	-	Network cannot be selected	64	Please contact IAI for more information.
PCON-CB/CGB		1		* Option	* Option	-	MECHATROLINK EtherCAT 	512 (768 for network spec.)	Please see P.255
MCON-C/CG		8		This model is network-compatible only.					256
MCON-LC/LCG		6		-	-	●	256		Please contact IAI for more information.
MSEL-PC/PG		4	Single-phase 100 ~ 230 VAC	-	-	●	30,000	Please contact IAI for more information.	
RCM-P6PC		1		Usable within the RCP6S Gateway system.				768	Please see P.279

* For the MCON controller, high-output enabled operation is only available if "high-output setting" is selected as an option. The maximum connectable axes with high-output enabled are C: 4 and LC: 3.

Foreword
 Slider Type
 Wide Slider Type
 Rod Type
 Radial Cylinder
 Wide Radial Cylinder
 Table Type
 Cleanroom Slider
 Cleanroom Wide Slider
 Dust/Splash-Proof Rod
 Dust/Splash-Proof Radial Cylinder*
 Dust/Splash-Proof Wide Radial Cylinder
 Options
 Reference Data
 Controller

RCP6(S)-SA6C

±10µm
Standard

±5µm
Optional

Simple
Dust-
proof

Battery-
less
Absolute

Motor
Unit
Type

Coupled
Motor

Body Width
58 mm

24v
Stepper
Motor

Model Specification Items

Series	Type	Encoder Type	Motor Type	Lead	Stroke	Applicable Controller/I/O Type	Cable Length	Options
RCP6: Separate Controller RCP6S: Built-in Controller	SA6C	WA	42P	20:20mm 12:12mm 6: 6mm 3: 3mm	50: 50mm 800: 800mm (50mm increments)	[RCP6] P3: PCON MCON MSEL P5: RCM-P6PC [RCP6S] SE: SIO Type	N: None P: 1m S: 3m M: 5m X□□: Specified Length R□□: Robot Cable	Please refer to the options table below.

* RCP6 does not include a controller. RCP6S includes a built-in controller.
* Please refer to P.15 for more information about the model specification items.

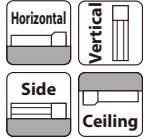

*Some limitations may apply to horizontal/side/ceiling mountings depending on the model. See page 204. Please contact IAI for more information.



- The maximum acceleration/deceleration is 1G for horizontal, and 0.5G for vertical use.
- The actuator specification displays the payload's maximum value, but it will vary depending on the acceleration and speed. Please refer to the "Selection Guidelines" (Tables of Payload by Speed/Acceleration) on P.207 for more details.
- Please refer to P.205 for performing push-motion operation.
- Depending on the ambient operational temperature, duty control is necessary for the RCP6S (built-in controller type) with lead 3/6. Please refer to P.247 for more information.

Correlation Diagrams of Speed and Payload

(1) High-output enabled with PCON/MCON/MSEL connected.

RCP6(S)-SA6C Horizontal mount

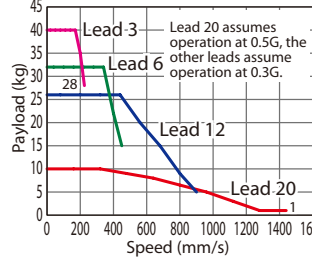

RCP6(S)-SA6C Vertical mount

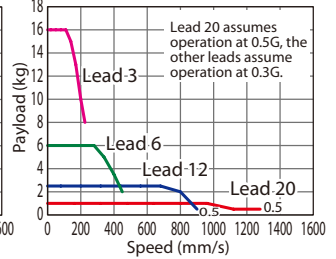

(2) High-output disabled with PCON/MCON connected.

RCP6(S)-SA6C Horizontal mount

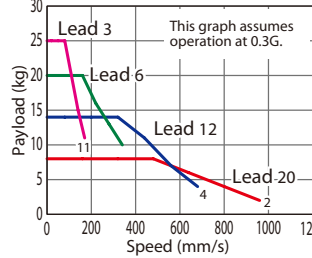

RCP6(S)-SA6C Vertical mount

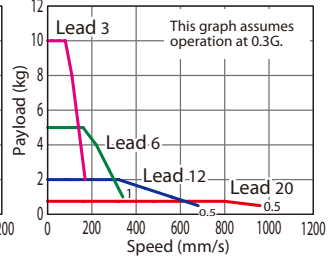

Actuator Specifications

Lead and Payload

* Push force only available during push mode w / limited speed.

Model Number	Lead (mm)	Connected Controller	Max. Payload		Max. Push Force (N)*
			Horizontal (kg)	Vertical (kg)	
RCP6(S)-SA6C-WA-42P-20-①-②-③-④	20	High-output Enabled	15	1	56
		High-output Disabled	8	0.75	
RCP6(S)-SA6C-WA-42P-12-①-②-③-④	12	High-output Enabled	28	2.5	93
		High-output Disabled	14	2	
RCP6(S)-SA6C-WA-42P-6-①-②-③-④	6	High-output Enabled	32	6	185
		High-output Disabled	20	5	
RCP6(S)-SA6C-WA-42P-3-①-②-③-④	3	High-output Enabled	40	16	370
		High-output Disabled	25	10	

Legend: ① Stroke ② Applicable controller/I/O type ③ Cable length ④ Options

Stroke and Max. Speed

(Unit: mm/s)

Lead (mm)	Connected Controller	Max. Speed								
		50~400 (Every 50mm)	450 (mm)	500 (mm)	550 (mm)	600 (mm)	650 (mm)	700 (mm)	750 (mm)	800 (mm)
20	High-output Enabled	1,440<1,280>	335<200>	1,130	970	840	735	650	575	
	High-output Disabled	960				840	735	650	575	
12	High-output Enabled	900	885	735	620	535	460	405	355	315
	High-output Disabled	680		620	535	460	405	355	315	
6	High-output Enabled	450	435	365	305	265	230	200	175	155
	High-output Disabled	340		305	265	230	200	175	155	
3	High-output Enabled	225	215	180	150	130	115	100	85	75
	High-output Disabled	170		150	130	115	100	85	75	

Values in brackets < > are for vertical use.

① Stroke

Stroke (mm)	RCP6	RCP6S	Stroke (mm)	RCP6	RCP6S
50	○	○	450	○	○
100	○	○	500	○	○
150	○	○	550	○	○
200	○	○	600	○	○
250	○	○	650	○	○
300	○	○	700	○	○
350	○	○	750	○	○
400	○	○	800	○	○

④ Options

Name	Option Code	Reference Page
Brake	B	See P.189
Cable exit direction (Top)	CJT	See P.189
Cable exit direction (Right)	CJR	See P.189
Cable exit direction (Left)	CJL	See P.189
Cable exit direction (Bottom)	CJB	See P.189
Designated grease coating specification	G1/G3/G4	
High-Precision Specification (*1)	HPR	See P.192
Non-motor end specification	NM	See P.194
Slider roller specification	SR	See P.195
Double slider specification (*2)	W	See P.196

(*1) When the lead is 20, it cannot be selected. Double slider specification cannot be selected.
(*2) Some leads cannot be selected. (Please see P.248)

When selecting multiple options, please list them in alphabetical order. (e.g. B-CJB-NM)

③ Cable Length

Cable Type	Cable Code	RCP6			RCP6S
		P3	P5	SE	
Standard	P (1m)	○	○	○	
	S (3m)	○	○	○	
	M (5m)	○	○	○	
	X06 (6m) ~X10 (10m)	○	○	○	
Specified Length	X11 (11m) ~X15 (15m)	○	○	○	
	X16 (16m) ~X20 (20m)	○	○	○	
	R01 (1m) ~R03 (3m)	○	○	○	
Robot Cable	R04 (4m) ~R05 (5m)	○	○	○	
	R06 (6m) ~R10 (10m)	○	○	○	
	R11 (11m) ~R15 (15m)	○	○	○	
	R16 (16m) ~R20 (20m)	○	○	○	
		○	○	○	
		○	○	○	

* Please refer to P.267 and 283 for more information regarding the maintenance cables.

Actuator Specifications

Item	Description
Drive system	Ball screw φ10mm, rolled C10
Positioning repeatability (*1)	±0.01mm [±0.005mm]
Lost motion	0.1mm or less
Base	Material: Aluminum with white alumite treatment
Static allowable moment	Ma: 48.5N·m, Mb: 69.3N·m, Mc: 103N·m
Dynamic allowable moment (*2)	Ma: 11.6N·m, Mb: 16.6N·m, Mc: 24.6N·m
Ambient operating temp. & humidity	0~40°C, 85% RH or less (Non-condensing)

* Reference for overhang load length: Ma: 220mm or less, Mb, Mc: 220mm or less

(*1) Values in [] are for high-precision (for lead 3/6/12) specification.

(*2) Assumes a standard rated life of 5,000km. The service life will vary depending on operation and installation conditions. Please refer to our website for more information regarding the directions of the allowable moment and overhang load length.

CAD drawings can be downloaded from our website.
www.intelligentactuator.com



*1 When the slider is returning to its home position, please be careful of interference from surrounding objects, as it will travel until it reaches the M.E.
M.E: Mechanical end S.E: Stroke end

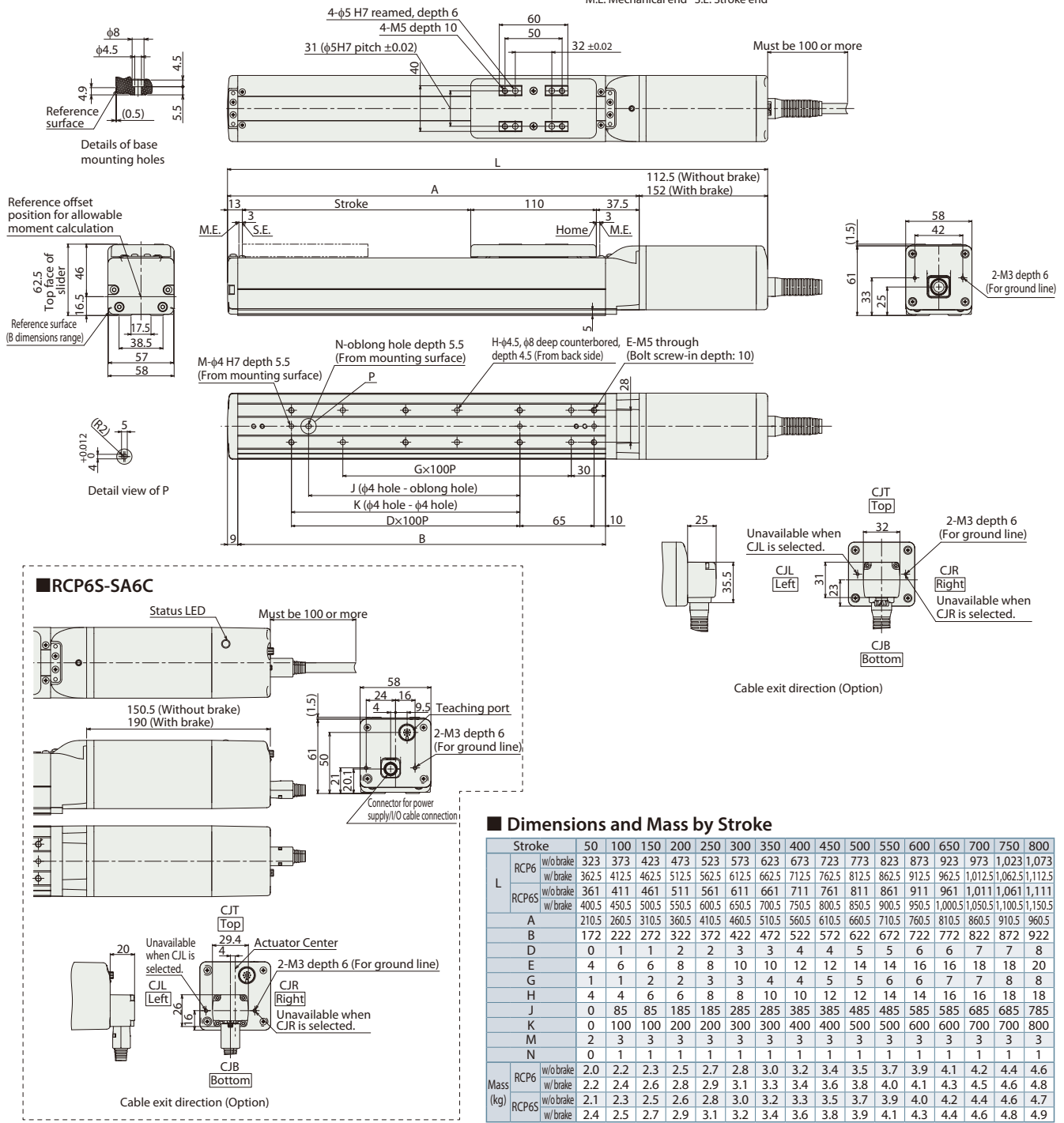

■ Dimensions and Mass by Stroke

Stroke	50	100	150	200	250	300	350	400	450	500	550	600	650	700	750	800			
L	RCP6		w/o brake	323	373	423	473	523	573	623	673	723	773	823	873	923	973	1,023	1,073
	w/ brake	362.5	412.5	462.5	512.5	562.5	612.5	662.5	712.5	762.5	812.5	862.5	912.5	962.5	1,012.5	1,062.5	1,112.5	1,162.5	
L	RCP6S		w/o brake	361	411	461	511	561	611	661	711	761	811	861	911	961	1,011	1,061	1,111
	w/ brake	400.5	450.5	500.5	550.5	600.5	650.5	700.5	750.5	800.5	850.5	900.5	950.5	1,000.5	1,050.5	1,100.5	1,150.5	1,200.5	
A	210.5	260.5	310.5	360.5	410.5	460.5	510.5	560.5	610.5	660.5	710.5	760.5	810.5	860.5	910.5	960.5			
B	172	222	272	322	372	422	472	522	572	622	672	722	772	822	872	922			
D	0	1	1	2	2	3	3	4	4	5	5	6	6	7	7	8			
E	4	6	6	8	8	10	10	12	12	14	14	16	16	18	18	20			
G	1	1	2	2	3	3	4	4	5	5	6	6	7	7	8	8			
H	4	4	6	6	8	8	10	10	12	12	14	14	16	16	18	18			
J	0	85	85	185	185	285	285	385	385	485	485	585	585	685	685	785			
K	0	100	100	200	200	300	300	400	400	500	500	600	600	700	700	800			
M	2	3	3	3	3	3	3	3	3	3	3	3	3	3	3	3			
N	0	1	1	1	1	1	1	1	1	1	1	1	1	1	1	1			
Mass (kg)	RCP6		w/o brake	2.0	2.2	2.3	2.5	2.7	2.8	3.0	3.2	3.4	3.5	3.7	3.9	4.1	4.2	4.4	4.6
	w/ brake	2.2	2.4	2.6	2.8	2.9	3.1	3.3	3.4	3.6	3.8	4.0	4.1	4.3	4.5	4.6	4.8	4.8	
RCP6S		w/o brake	2.1	2.3	2.5	2.6	2.8	3.0	3.2	3.3	3.5	3.7	3.9	4.0	4.2	4.4	4.6	4.7	
w/ brake	2.4	2.5	2.7	2.9	3.1	3.2	3.4	3.6	3.8	3.9	4.1	4.3	4.4	4.6	4.8	4.9			

② Applicable Controllers

The RCP6 series actuators can be operated by the controllers indicated below. Please select the type depending on your intended use. * Please refer to P.271 for more information about the built-in controller of RCP6S series.

Name	External view	Max. number of controlled axes	Input power	Control method				Maximum number of positioning points	Reference page
				Positioner	Pulse train	Program	Network * Option		
PCON-CYB/PLB/POB		1	DC24V	●	●	—	Network cannot be selected	64	Please contact IAI for more information.
PCON-CB/CGB		1		* Option	* Option	—	DeviceNet MECHATROLINK CC-Link EtherCAT EtherNet/IP CompoNet	512 (768 for network spec.)	Please see P.255
MCON-C/CG		8		This model is network-compatible only.				Note: The type of compatible networks will vary depending on the controller. Please refer to reference page for more information.	256
MCON-LC/LCG		6		—	—	●	256		Please contact IAI for more information.
MSEL-PC/PG		4	Single-phase 100 ~ 230 VAC	—	—	●	30,000	Please contact IAI for more information.	
RCM-P6PC		1		Usable within the RCP6S Gateway system.				768	Please see P.279

* For the MCON controller, high-output enabled operation is only available if "high-output setting" is selected as an option. The maximum connectable axes with high-output enabled are C: 4 and LC: 3.

Foreword
Slider Type
Wide Slider Type
Rod Type
Radial Cylinder
Wide Radial Cylinder
Table Type
Cleanroom Slider
Cleanroom Wide Slider
Dust/Splash-Proof Rod
Dust/Splash-Proof Radial Cylinder
Dust/Splash-Proof Wide Radial Cylinder
Options
Reference Data
Controller

RCP6(S)-SA7C



Model Specification Items

Series	Type	Encoder Type	Motor Type	Lead	Stroke	Applicable Controller/I/O Type	Cable Length	Options
RCP6: Separate Controller RCP6S: Built-in Controller	SA7C	WA	56P	24:24mm 16:16mm 8: 8mm 4: 4mm	50: 50mm 800: 800mm (50mm increments)	[RCP6] P3: PCOM MCON MSEL P5: RCM-P6PC [RCP6S] SE: SIO Type	N: None P: 1m S: 3m M: 5m X□□: Specified Length R□□: Robot Cable	Please refer to the options table below.

* RCP6 does not include a controller. RCP6S includes a built-in controller.
* Please refer to P.15 for more information about the model specification items.

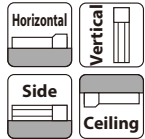

*Some limitations may apply to horizontal/side/ceiling mountings depending on the model. See page 204. Please contact IAI for more information.



POINT Selection Notes

- The maximum acceleration/deceleration is 1G for horizontal, and 0.5G for vertical use.
- The actuator specification displays the payload's maximum value, but it will vary depending on the acceleration and speed. Please refer to the "Selection Guidelines" (Tables of Payload by Speed/Acceleration) on P.207 for more details.
- Please refer to P205 for performing push-motion operation.
- Depending on the ambient operational temperature, duty control is necessary for the RCP6S (built-in controller type) with lead 4/8/16. Please refer to P.247 for more information.

Correlation Diagrams of Speed and Payload

(1) High-output enabled with PCOM/MCON/MSEL connected.

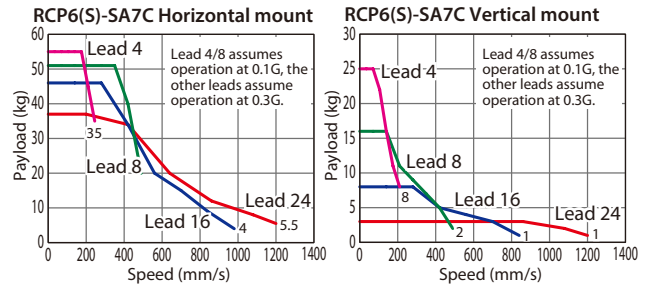

(2) High-output disabled with PCOM/MCON connected.

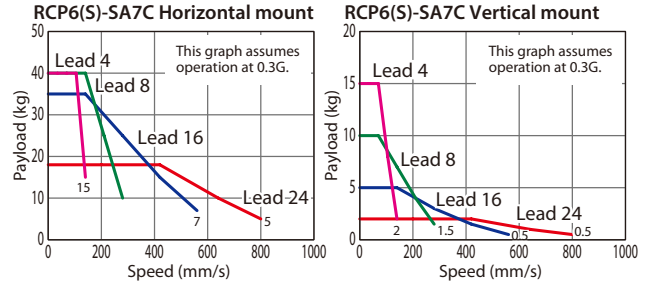

Actuator Specifications

Lead and Payload

* Push force only available during push mode w / limited speed.

Model Number	Lead (mm)	Connected Controller	Max. Payload		Max. Push Force (N)*
			Horizontal (kg)	Vertical (kg)	
RCP6(S)-SA7C-WA-56P-24-①②③④	24	High-output Enabled	37	3	112
		High-output Disabled	18	2	
RCP6(S)-SA7C-WA-56P-16-①②③④	16	High-output Enabled	46	8	168
		High-output Disabled	35	5	
RCP6(S)-SA7C-WA-56P-8-①②③④	8	High-output Enabled	51	16	336
		High-output Disabled	40	10	
RCP6(S)-SA7C-WA-56P-4-①②③④	4	High-output Enabled	55	25	673
		High-output Disabled	40	15	

Legend: ① Stroke ② Applicable controller/I/O type ③ Cable length ④ Options

Stroke and Max. Speed

(Unit: mm/s)

Lead (mm)	Connected Controller	Max. Speed							
		50~500 (Every 50mm)	550 (mm)	600 (mm)	650 (mm)	700 (mm)	750 (mm)	800 (mm)	
24	High-output Enabled	1,200		1,095	965	850	760		
	High-output Disabled	800					760		
16	High-output Enabled	980<840>	965<840>	830	720	635	560	500	
	High-output Disabled	560					500		
8	High-output Enabled	490	475	410	355	315	275	245	
	High-output Disabled	280					275	245	
4	High-output Enabled	245<210>	235<210>	205	175	155	135	120	
	High-output Disabled	140					135	120	

Values in brackets < > are for vertical use.

① Stroke

Stroke (mm)	RCP6	RCP6S	Stroke (mm)	RCP6	RCP6S
50	○	○	450	○	○
100	○	○	500	○	○
150	○	○	550	○	○
200	○	○	600	○	○
250	○	○	650	○	○
300	○	○	700	○	○
350	○	○	750	○	○
400	○	○	800	○	○

④ Options

Name	Option Code	Reference Page
Brake	B	See P.189
Cable exit direction (Top)	CJT	See P.189
Cable exit direction (Right)	CJR	See P.189
Cable exit direction (Left)	CJL	See P.189
Cable exit direction (Bottom)	CJB	See P.189
Designated grease coating specification	G1/G3/G4	
High-Precision Specification (*1)	HPR	See P.192
Non-motor end specification	NM	See P.194
Slider roller specification	SR	See P.195
Double slider specification (*2)	W	See P.196

(*1) When the lead is 16/24, it cannot be selected. Double slider specification cannot be selected.

(*2) Some leads cannot be selected. (Please see P.248)

When selecting multiple options, please list them in alphabetical order. (e.g. B-CJB-NM)

③ Cable Length

Cable Type	Cable Code	RCP6			RCP6S
		P3	P5	SE	
Standard	P (1m)	○	○	○	○
	S (3m)	○	○	○	○
	M (5m)	○	○	○	○
Specified Length	X06 (6m) ~X10 (10m)	○	○	○	○
	X11 (11m) ~X15 (15m)	○	○	○	○
	X16 (16m) ~X20 (20m)	○	○	○	○
	R01 (1m) ~R03 (3m)	○	○	○	○
Robot Cable	R04 (4m) ~R05 (5m)	○	○	○	○
	R06 (6m) ~R10 (10m)	○	○	○	○
	R11 (11m) ~R15 (15m)	○	○	○	○
	R16 (16m) ~R20 (20m)	○	○	○	○

* Please refer to P.267 and 283 for more information regarding the maintenance cables.

Actuator Specifications

Item	Description
Drive system	Ball screw φ12mm, rolled C10
Positioning repeatability (*1)	±0.01mm [±0.005mm]
Lost motion	0.1mm or less
Base	Material: Aluminum with white alumite treatment
Static allowable moment	Ma: 115N·m, Mb: 115N·m, Mc: 229N·m
Dynamic allowable moment (*2)	Ma: 44.7N·m, Mb: 44.7N·m, Mc: 89.1N·m
Ambient operating temp. & humidity	0~40°C, 85% RH or less (Non-condensing)

* Reference for overhang load length: Ma: 300mm or less, Mb, Mc: 300mm or less

(*1) Values in [] are for high-precision (for lead 4/8) specification.

(*2) Assumes a standard rated life of 5,000km. The service life will vary depending on operation and installation conditions.

Please refer to our website for more information regarding the directions of the allowable moment and overhang load length.

RCP6(S)-SA8C



Model Specification Items

Series	Type	Encoder Type	Motor Type	Lead	Stroke	Applicable Controller/I/O Type	Cable Length	Options
RCP6: Separate Controller RCP6S: Built-in Controller	SA8C	WA: Battery-less Absolute	56SP: High-thrust Stepper Motor	30: 30mm 20: 20mm 10: 10mm 5: 5mm	50: 50mm 1,100: 1,100mm (50mm increments)	[RCP6] P4: PCON-CFB/CGFB [RCP6S] SE: SIO Type	N: None P: 1m S: 3m M: 5m X□□: Specified Length R□□: Robot Cable	Please refer to the options table below.

* RCP6 does not include a controller. RCP6S includes a built-in controller.
* Please refer to P.15 for more information about the model specification items.

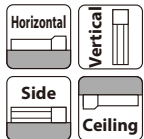

*Some limitations may apply to horizontal/side/ceiling mountings depending on the model. See page 204. Please contact IAI for more information.



POINT Selection Notes

- The maximum acceleration/deceleration is 1G for horizontal, and 0.5G for vertical use.
- The actuator specification displays the payload's maximum value, but it will vary depending on the acceleration and speed. Please refer to the "Selection Guidelines" (Tables of Payload by Speed/Acceleration) on P.207 for more details.
- Please refer to P205 for performing push-motion operation.

Correlation Diagrams of Speed and Payload

PCON connected.

RCP6(S)-SA8C Horizontal mount

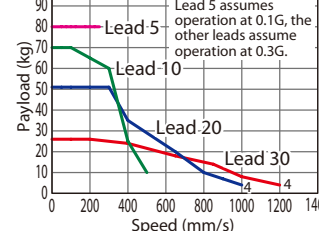

RCP6(S)-SA8C Vertical mount

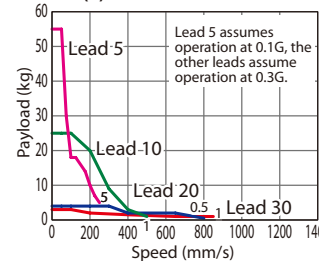

Actuator Specifications

Lead and Payload

* Push force only available during push mode w / limited speed.

Model Number	Lead (mm)	Max. Payload		Max. Push Force (N)*
		Horizontal (kg)	Vertical (kg)	
RCP6(S)-SA8C-WA-56SP-30-①-②-③-④	30	28	3	159
RCP6(S)-SA8C-WA-56SP-20-①-②-③-④	20	60	4	239
RCP6(S)-SA8C-WA-56SP-10-①-②-③-④	10	70	25	478
RCP6(S)-SA8C-WA-56SP-5-①-②-③-④	5	80	55	956

Legend: ① Stroke ② Applicable controller/I/O type ③ Cable length ④ Options

Stroke and Max. Speed

(Unit: mm/s)

Lead (mm)	50~650	700	750	800	850	900	950	1,000	1,050	1,100
	(Every 50mm)	(mm)	(mm)	(mm)	(mm)	(mm)	(mm)	(mm)	(mm)	(mm)
30	1,200 <850>		1,155 <850>	1,040 <850>	940 <850>	855 <850>	780	715	660	
20	1,000 <800>	950 <800>	860 <800>	770	695	630	570	520	480	440
10	500	480	430	385	345	310	285	260	235	220
5	250	240	215	190	175	155	140	130	120	110

Values in brackets < > are for vertical use.

① Stroke

Stroke (mm)	RCP6	RCP6S	Stroke (mm)	RCP6	RCP6S
50	○	○	600	○	○
100	○	○	650	○	○
150	○	○	700	○	○
200	○	○	750	○	○
250	○	○	800	○	○
300	○	○	850	○	○
350	○	○	900	○	○
400	○	○	950	○	○
450	○	○	1000	○	○
500	○	○	1050	○	○
550	○	○	1100	○	○

④ Options

Name	Option Code	Reference Page
Brake	B	See P.189
Cable exit direction (Top)	CJT	See P.189
Cable exit direction (Right)	CJR	See P.189
Cable exit direction (Left)	CJL	See P.189
Cable exit direction (Bottom)	CJB	See P.189
Designated grease coating specification	G1/G3/G4	
High-Precision Specification (*1)	HPR	See P.192
Non-motor end specification	NM	See P.194
Slider roller specification	SR	See P.195
Double slider specification (*2)	W	See P.196

(*1) When the lead is 20/30, it cannot be selected. Double slider specification cannot be selected.
(*2) Some leads cannot be selected. (Please see P. 248)
When selecting multiple options, please list them in alphabetical order. (e.g. B-CJB-NM)

③ Cable Length

Cable Type	Cable Code	RCP6	RCP6S
Standard	P (1m)	○	○
	S (3m)	○	○
	M (5m)	○	○
Specified Length	X06 (6m) ~X10 (10m)	○	○
	X11 (11m) ~X15 (15m)	○	○
	X16 (16m) ~X20 (20m)	○	○
	R01 (1m) ~R03 (3m)	○	○
Robot Cable	R04 (4m) ~R05 (5m)	○	○
	R06 (6m) ~R10 (10m)	○	○
	R11 (11m) ~R15 (15m)	○	○
	R16 (16m) ~R20 (20m)	○	○

* Please refer to P.267 and 283 for more information regarding the maintenance cables.

Actuator Specifications

Item	Description
Drive system	Ball screw φ16mm, rolled C10
Positioning repeatability (*1)	±0.01mm [±0.005mm]
Lost motion	0.1mm or less
Base	Material: Aluminum with white alumite treatment
Static allowable moment	Ma: 219N·m, Mb: 219N·m, Mc: 414N·m
Dynamic allowable moment (*2)	Ma: 77.0N·m, Mb: 77.0N·m, Mc: 146N·m
Ambient operating temp. & humidity	0~40°C, 85% RH or less (Non-condensing)

* Reference for overhang load length: Ma: 400mm or less, Mb, Mc: 400mm or less
(*1) Values in [] are for high-precision for lead 5/10 specification.
(*2) Assumes a standard rated life of 5,000km. The service life will vary depending on operation and installation conditions.
Please refer to our website for more information regarding the directions of the allowable moment and overhang load length.

CAD drawings can be downloaded from our website.
www.intelligentactuator.com



*1 When the slider is returning to its home position, please be careful of interference from surrounding objects, as it will travel until it reaches the M.E.
M.E: Mechanical end S.E: Stroke end

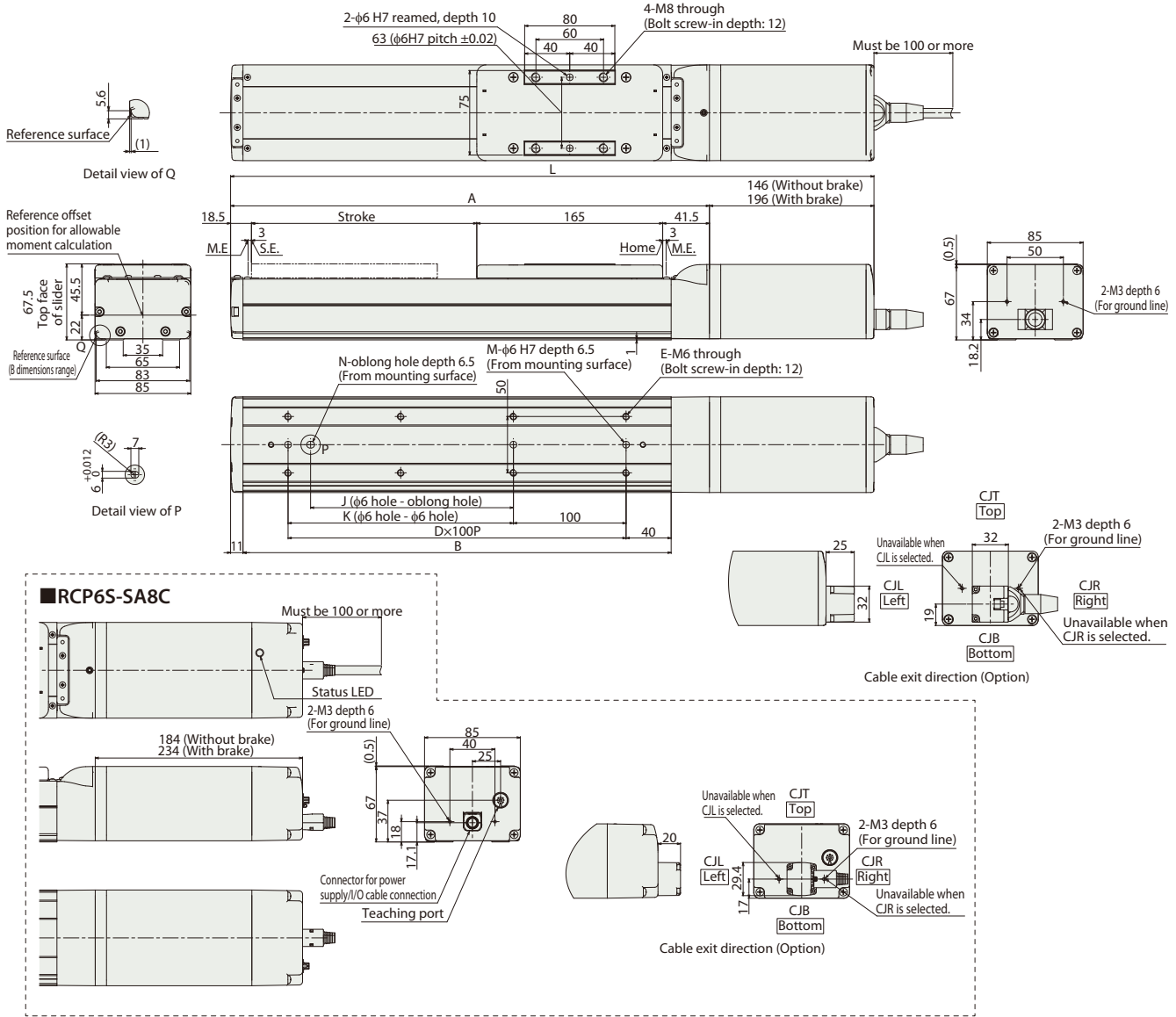

■ Dimensions and Mass by Stroke

Stroke	50	100	150	200	250	300	350	400	450	500	550	600	650	700	750	800	850	900	950	1,000	1,050	1,100		
L	RCP6	w/o brake	421	471	521	571	621	671	721	771	821	871	921	971	1,021	1,071	1,121	1,171	1,221	1,271	1,321	1,371	1,421	1,471
		w/ brake	471	521	571	621	671	721	771	821	871	921	971	1,021	1,071	1,121	1,171	1,221	1,271	1,321	1,371	1,421	1,471	1,521
	RCP6S	w/o brake	459	509	559	609	659	709	759	809	859	909	959	1,009	1,059	1,109	1,159	1,209	1,259	1,309	1,359	1,409	1,459	1,509
		w/ brake	509	559	609	659	709	759	809	859	909	959	1,009	1,059	1,109	1,159	1,209	1,259	1,309	1,359	1,409	1,459	1,509	1,559
A	275	325	375	425	475	525	575	625	675	725	775	825	875	925	975	1,025	1,075	1,125	1,175	1,225	1,275	1,325	1,375	
B	230	280	330	380	430	480	530	580	630	680	730	780	830	880	930	980	1,030	1,080	1,130	1,180	1,230	1,280	1,330	
D	1	2	2	3	3	4	4	5	5	6	6	7	7	8	8	9	9	10	10	11	11	12	12	
E	4	6	6	8	8	10	10	12	12	14	14	16	16	18	18	20	20	22	22	24	24	26	26	
J	0	0	80	180	180	280	280	380	380	480	480	580	580	680	680	780	780	880	880	980	980	1,080	1,080	
K	0	100	100	200	200	300	300	400	400	500	500	600	600	700	700	800	800	900	900	1,000	1,000	1,100	1,100	
M	2	3	3	3	3	3	3	3	3	3	3	3	3	3	3	3	3	3	3	3	3	3	3	
N	0	0	1	1	1	1	1	1	1	1	1	1	1	1	1	1	1	1	1	1	1	1	1	
Mass (kg)	RCP6	w/o brake	4.5	4.7	5.0	5.3	5.5	5.8	6.1	6.4	6.6	6.9	7.2	7.5	7.7	8.0	8.3	8.5	8.8	9.1	9.4	9.6	9.9	10.2
		w/ brake	5.0	5.2	5.5	5.8	6.1	6.3	6.6	6.9	7.1	7.4	7.7	8.0	8.2	8.5	8.8	9.1	9.3	9.6	9.9	10.1	10.4	10.7
	RCP6S	w/o brake	4.7	4.9	5.2	5.5	5.8	6.0	6.3	6.6	6.9	7.1	7.4	7.7	7.9	8.2	8.5	8.8	9.0	9.3	9.6	9.9	10.1	10.4
		w/ brake	5.2	5.5	5.7	6.0	6.3	6.5	6.8	7.1	7.4	7.6	7.9	8.2	8.5	8.7	9.0	9.3	9.5	9.8	10.1	10.4	10.6	10.9

② Applicable Controllers

The RCP6 series actuators can be operated by the controllers indicated below. Please select the type depending on your intended use. * Please refer to P.271 for more information about the built-in controller of RCP6S series.

Name	External view	Max. number of controlled axes	Input power	Control method				Maximum number of positioning points	Reference page
				Positioner	Pulse train	Program	Network *Option		
PCON-CFB/CGFB		1	DC24V	*Option	*Option	-	DeviceNet CompoNet EtherNet/IP CC-Link MECHATROLINK EtherCAT CANopen	512 (768 for network spec.)	Please see P.255

Foreword
Slider Type
Wide Slider Type
Rod Type
Radial Cylinder
Wide Radial Cylinder
Table Type
Cleanroom Slider
Cleanroom Wide Slider
Dust/Splash-Proof Rod
Dust/Splash-Proof Radial Cylinder
Dust/Splash-Proof Wide Radial Cylinder
Options
Reference Data
Controller

RCP6(S)-SA4R



Model Specification Items

Series	Type	Encoder Type	Motor Type	Lead	Stroke	Applicable Controller/I/O Type	Cable Length	Options
RCP6: Separate Controller RCP6S: Built-in Controller	SA4R	WA: Battery-less Absolute	35P: Stepper Motor 35□ Size	16:16mm 10:10mm 5: 5mm 2.5:2.5mm	50: 50mm 500: 500mm (50mm increments)	[RCP6] P3: PCON MCON MSEL P5: RCM-P6PC [RCP6S] SE: SIO Type	N: None P: 1m S: 3m M: 5m P5: RCM-P6PC X□: Specified Length R□: Robot Cable	Please refer to the options table below. *Please make sure to specify either ML or MR when ordering the side-mounted motor type.

* RCP6 does not include a controller. RCP6S includes a built-in controller.
* Please refer to P.15 for more information about the model specification items.

* Body width does not include the width of the side-mounted motor.

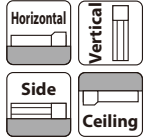

*Some limitations may apply to horizontal/side/ceiling mountings depending on the model. See page 204. Please contact IAI for more information.



The figure above is the motor side-mounted to the left (ML).



- (1) The maximum acceleration/deceleration is 1G for horizontal, and 0.5G for vertical use.
- (2) The actuator specification displays the payload's maximum value, but it will vary depending on the acceleration and speed. Please refer to the "Selection Guidelines" (Tables of Payload by Speed/Acceleration) on P.209 for more details.
- (3) Please refer to P205 for performing push-motion operation.

Correlation Diagrams of Speed and Payload

(1) High-output enabled with PCON/MCON/MSEL connected.

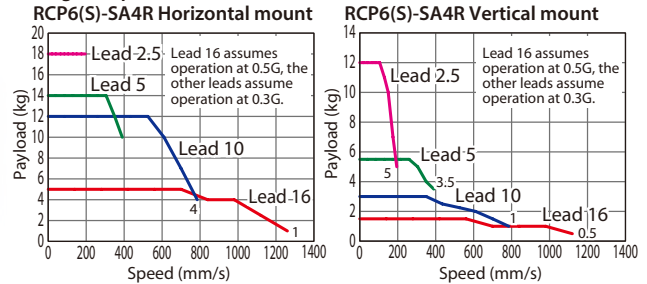

(2) High-output disabled with PCON/MCON connected.

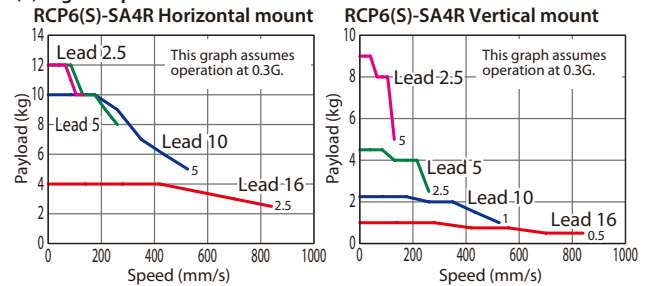

Actuator Specifications

Lead and Payload

* Push force only available during push mode w / limited speed.

Model Number	Lead (mm)	Connected Controller	Max. Payload		Max. Push Force (N)*
			Horizontal (kg)	Vertical (kg)	
RCP6(S)-SA4R-WA-35P-16-①②③④	16	High-output Enabled	7	1.5	48
		High-output Disabled	4	1	
RCP6(S)-SA4R-WA-35P-10-①②③④	10	High-output Enabled	12	3	77
		High-output Disabled	10	2.25	
RCP6(S)-SA4R-WA-35P-5-①②③④	5	High-output Enabled	14	5.5	155
		High-output Disabled	12	4.5	
RCP6(S)-SA4R-WA-35P-2.5-①②③④	2.5	High-output Enabled	18	12	310
		High-output Disabled	12	9	

Legend: ① Stroke ② Applicable controller/I/O type ③ Cable length ④ Options

Stroke and Max. Speed

(Unit: mm/s)

Lead (mm)	Connected Controller	50~400 (Every 50mm)		
		450 (mm)	500 (mm)	500 (mm)
16	High-output Enabled	1,260 < 1,120 >	1,060	875
	High-output Disabled	840		
10	High-output Enabled	785	675	555
	High-output Disabled	525		
5	High-output Enabled	390	330	275
	High-output Disabled	260		
2.5	High-output Enabled	195	165	135
	High-output Disabled	130		

Values in brackets < > are for vertical use.

① Stroke

Stroke (mm)	RCP6	RCP6S	Stroke (mm)	RCP6	RCP6S
50	○	○	300	○	○
100	○	○	350	○	○
150	○	○	400	○	○
200	○	○	450	○	○
250	○	○	500	○	○

③ Cable Length

Cable Type	Cable Code	RCP6			RCP6S
		P3	P5	SE	SE
Standard	P (1m)	○	○	○	○
	S (3m)	○	○	○	○
	M (5m)	○	○	○	○
Specified Length	X06 (6m) ~X10 (10m)	○	○	○	○
	X11 (11m) ~X15 (15m)	○	○	○	○
	X16 (16m) ~X20 (20m)	○	○	○	○
	X21 (21m) ~X25 (25m)	○	○	○	○
Robot Cable	R01 (1m) ~R03 (3m)	○	○	○	○
	R04 (4m) ~R05 (5m)	○	○	○	○
	R06 (6m) ~R10 (10m)	○	○	○	○
	R11 (11m) ~R15 (15m)	○	○	○	○
	R16 (16m) ~R20 (20m)	○	○	○	○
	R21 (21m) ~R25 (25m)	○	○	○	○

* Please refer to P.267 and 283 for more information regarding the maintenance cables.

④ Options

Name	Option Code	Reference Page
Brake	B	See P.189
Cable exit direction (Outside)	CJO	See P.189
Motor side-mounted to the left	ML	See P.193
Motor side-mounted to the right	MR	See P.193
Non-motor end specification	NM	See P.194
Slider roller specification	SR	See P.195
Double slider specification (*1)	W	See P.196

(*1) Some leads cannot be selected. (Please see P. 248)

When selecting multiple options, please list them in alphabetical order. (e.g. B-CJB-NM)

Actuator Specifications

Item	Description
Drive system	Ball screw φ8mm, rolled C10
Positioning repeatability	±0.01mm
Lost motion	0.1mm or less
Base	Material: Aluminum with white alumite treatment
Static allowable moment	Ma: 13.0N·m, Mb: 18.6N·m, Mc: 25.3N·m
Dynamic allowable moment (*)	Ma: 5.0N·m, Mb: 7.1N·m, Mc: 9.7N·m
Ambient operating temp. & humidity	0~40°C, 85% RH or less (Non-condensing)

* Reference for overhang load length: Ma: 150mm or less, Mb, Mc: 150mm or less

(*) Assumes a standard rated life of 5,000km. The service life will vary depending on operation and installation conditions.

Please refer to our website for more information regarding the directions of the allowable moment and overhang load length.

CAD drawings can be downloaded from our website.
www.intelligentactuator.com

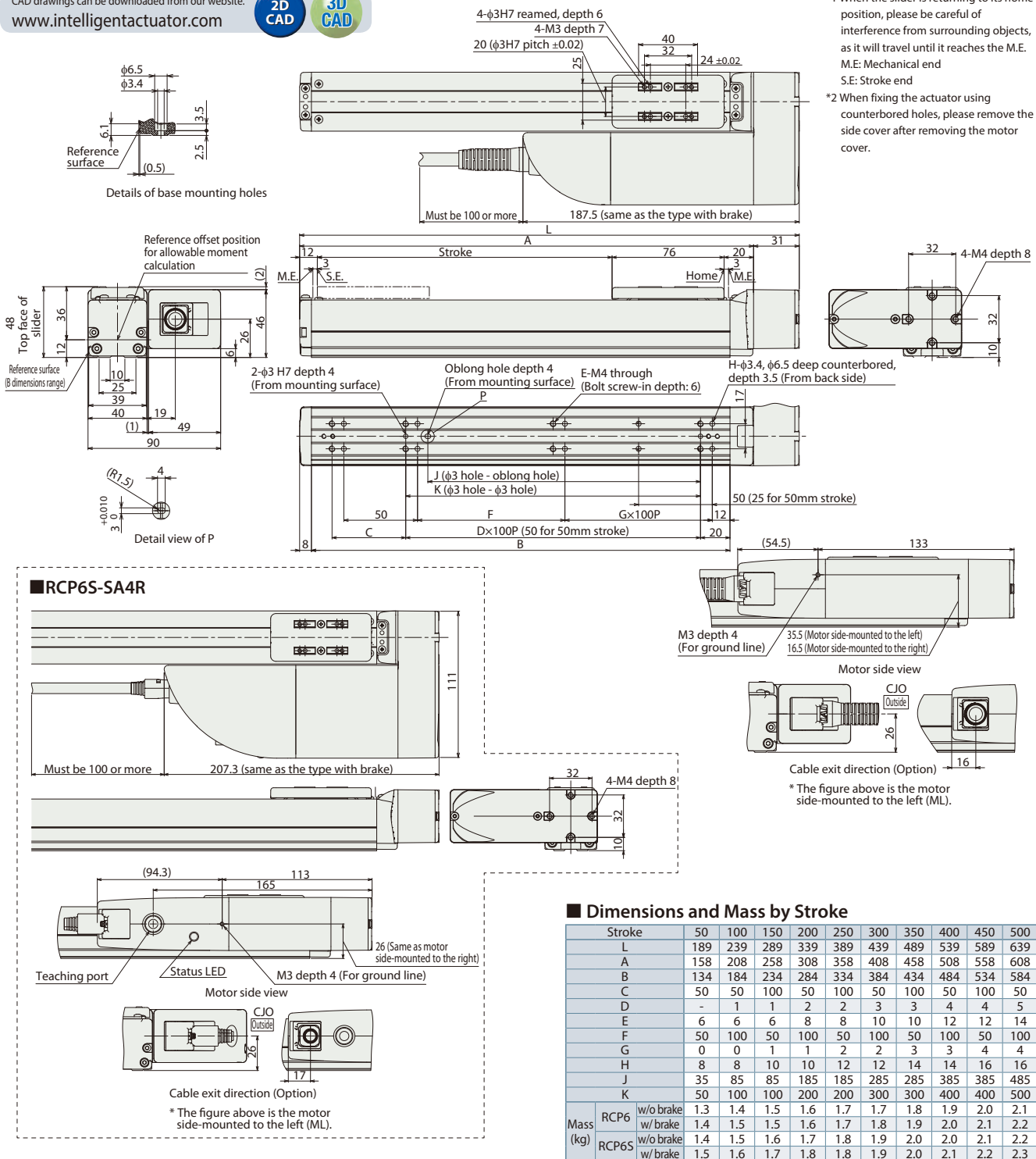

*1 When the slider is returning to its home position, please be careful of interference from surrounding objects, as it will travel until it reaches the M.E.
M.E: Mechanical end
S.E: Stroke end
*2 When fixing the actuator using counterbored holes, please remove the side cover after removing the motor cover.

■ Dimensions and Mass by Stroke

Stroke	50	100	150	200	250	300	350	400	450	500		
L	189	239	289	339	389	439	489	539	589	639		
A	158	208	258	308	358	408	458	508	558	608		
B	134	184	234	284	334	384	434	484	534	584		
C	50	50	100	50	100	50	100	50	100	50		
D	-	1	1	2	2	3	3	4	4	5		
E	6	6	6	8	8	10	10	12	12	14		
F	50	100	50	100	50	100	50	100	50	100		
G	0	0	1	1	2	2	3	3	4	4		
H	8	8	10	10	12	12	14	14	16	16		
J	35	85	85	185	185	285	285	385	385	485		
K	50	100	100	200	200	300	300	400	400	500		
Mass (kg)	RCP6	w/o brake	1.3	1.4	1.5	1.6	1.7	1.7	1.8	1.9	2.0	2.1
		w/brake	1.4	1.5	1.5	1.6	1.7	1.8	1.9	2.0	2.1	2.2
	RCP6S	w/o brake	1.4	1.5	1.6	1.7	1.8	1.9	2.0	2.0	2.1	2.2
		w/brake	1.5	1.6	1.7	1.8	1.8	1.9	2.0	2.1	2.2	2.3

② Applicable Controllers

The RCP6 series actuators can be operated by the controllers indicated below. Please select the type depending on your intended use. * Please refer to P.271 for more information about the built-in controller of RCP6S series.

Name	External view	Max. number of controlled axes	Input power	Control method				Maximum number of positioning points	Reference page
				Positioner	Pulse train	Program	Network * Option		
PCON-CYB/PLB/POB		1	DC24V	●	●	-	Network cannot be selected	64	Please contact IAI for more information.
PCON-CB/CGB		1		* Option	* Option	-	DeviceNet MECHATROLINK CC-Link EtherCAT EtherNet/IP CANopen CompoNet	512 (768 for network spec.)	Please see P.255
MCON-C/CG		8		This model is network-compatible only.					256
MCON-LC/LCG		6		-	-	●		256	Please contact IAI for more information.
MSEL-PC/PG		4	Single-phase 100 ~ 230 VAC	-	-	●		30,000	Please contact IAI for more information.
RCM-P6PC		1		Usable within the RCP6S Gateway system.				768	Please see P.279

* For the MCON controller, high-output enabled operation is only available if "high-output setting" is selected as an option. The maximum connectable axes with high-output enabled are C: 4 and LC: 3.

Foreword
Slider Type
Wide Slider Type
Rod Type
Radial Cylinder
Wide Radial Cylinder
Wide Slider Type
Table Type
Cleanroom Slider
Cleanroom Wide Slider
Dust/Splash-Proof Rod
Dust/Splash-Proof Radial Cylinder
Dust/Splash-Proof Wide Radial Cylinder
Options
Reference Data
Controller

RCP6(S)-SA6R

±10μm Standard | Simple Dust-proof | Battery-less Absolute | Motor Unit Type | Side-mounted Motor | Body Width 58mm* | 24v Stepper Motor

Model Specification Items	Series	Type	Encoder Type	Motor Type	Lead	Stroke	Applicable Controller/I/O Type	Cable Length	Options
	SA6R	WA	42P						
	RCP6: Separate Controller RCP6S: Built-in Controller		WA: Battery-less Absolute	42P: Stepper Motor 42□ Size	20: 20mm 12: 12mm 6: 6mm 3: 3mm	50: 50mm 800: 800mm (50mm increments)	[RCP6] P3: PCON MCON MSEL P5: RCM-P6PC [RCP6S] SE: SIO Type	N: None P: 1m S: 3m M: 5m X□□: Specified Length R□□: Robot Cable	Please refer to the options table below. * Please make sure to specify either ML or MR when ordering the side-mounted motor type.

* RCP6 does not include a controller. RCP6S includes a built-in controller.
* Please refer to P.15 for more information about the model specification items.

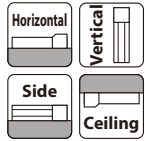

*Some limitations may apply to horizontal/side/ceiling mountings depending on the model. See page 204. Please contact IAI for more information.



The figure above is the motor side-mounted to the left (ML).

POINT	Selection Notes

Correlation Diagrams of Speed and Payload

(1) High-output enabled with PCON/MCON/MSEL connected.

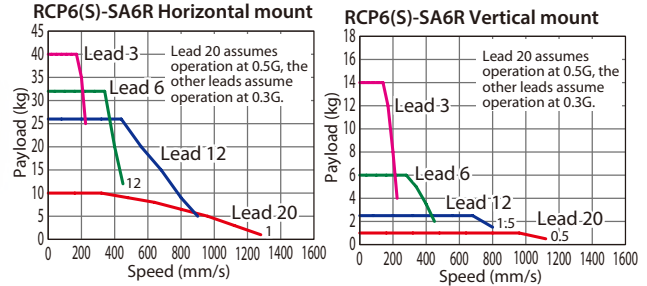

(2) High-output disabled with PCON/MCON connected.

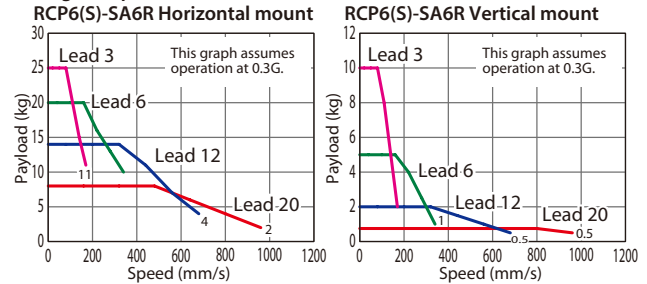

Actuator Specifications

■ Lead and Payload * Push force only available during push mode w / limited speed.

Model Number	Lead (mm)	Connected Controller	Max. Payload		Max. Push Force (N)*
			Horizontal (kg)	Vertical (kg)	
RCP6(S)-SA6R-WA-42P-20-①-②-③-④	20	High-output Enabled	15	1	56
		High-output Disabled	8	0.75	
RCP6(S)-SA6R-WA-42P-12-①-②-③-④	12	High-output Enabled	28	2.5	93
		High-output Disabled	14	2	
RCP6(S)-SA6R-WA-42P-6-①-②-③-④	6	High-output Enabled	32	6	185
		High-output Disabled	20	5	
RCP6(S)-SA6R-WA-42P-3-①-②-③-④	3	High-output Enabled	40	14	370
		High-output Disabled	25	10	

Legend: ① Stroke ② Applicable controller/I/O type ③ Cable length ④ Options

■ Stroke and Max. Speed (Unit: mm/s)

Lead (mm)	Connected Controller	Stroke (mm)												
		50~400 (Every 50mm)	450	500	550	600	650	700	750	800				
20	High-output Enabled	1,280<1,120>		1,130<1,120>		970	840	735	650	575				
	High-output Disabled	960								840	735	650	575	
12	High-output Enabled	900<800>	885<800>	735	620	535	460	405	355	315				
	High-output Disabled	680								620	535	460	405	355
6	High-output Enabled	450	435	365	305	265	230	200	175	155				
	High-output Disabled	340		305		265	230	200	175	155				
3	High-output Enabled	225	215	180	150	130	115	100	85	75				
	High-output Disabled	170		150		130	115	100	85	75				

Values in brackets < > are for vertical use.

① Stroke

Stroke (mm)	RCP6	RCP6S	Stroke (mm)	RCP6	RCP6S
50	○	○	450	○	○
100	○	○	500	○	○
150	○	○	550	○	○
200	○	○	600	○	○
250	○	○	650	○	○
300	○	○	700	○	○
350	○	○	750	○	○
400	○	○	800	○	○

④ Options

Name	Option Code	Reference Page
Brake	B	See P.189
Cable exit direction (Outside)	CJO	See P.189
Motor side-mounted to the left	ML	See P.193
Motor side-mounted to the right	MR	See P.193
Non-motor end specification	NM	See P.194
Slider roller specification	SR	See P.195
Double slider specification (*1)	W	See P.196

(*1) Some leads cannot be selected. (Please see P. 248)

When selecting multiple options, please list them in alphabetical order. (e.g. B-CJB-NM)

③ Cable Length

Cable Type	Cable Code	RCP6			RCP6S
		P3	P5	SE	
Standard	P (1m)	○	○	○	
	S (3m)	○	○	○	
	M (5m)	○	○	○	
Specified Length	X06 (6m) ~X10 (10m)	○	○	○	
	X11 (11m) ~X15 (15m)	○	○	○	
	X16 (16m) ~X20 (20m)	○	○	○	
	R01 (1m) ~R03 (3m)	○	○	○	
Robot Cable	R04 (4m) ~R05 (5m)	○	○	○	
	R06 (6m) ~R10 (10m)	○	○	○	
	R11 (11m) ~R15 (15m)	○	○	○	
	R16 (16m) ~R20 (20m)	○	○	○	
		○	○	○	
		○	○	○	

* Please refer to P.267 and 283 for more information regarding the maintenance cables.

Actuator Specifications

Item	Description
Drive system	Ball screw φ10mm, rolled C10
Positioning repeatability	±0.01mm
Lost motion	0.1mm or less
Base	Material: Aluminum with white alumite treatment
Static allowable moment	Ma: 48.5N·m, Mb: 69.3N·m, Mc: 103N·m
Dynamic allowable moment (*)	Ma: 11.6N·m, Mb: 16.6N·m, Mc: 24.6N·m
Ambient operating temp. & humidity	0~40°C, 85% RH or less (Non-condensing)

* Reference for overhang load length: Ma: 220mm or less, Mb, Mc: 220mm or less

(*) Assumes a standard rated life of 5,000km. The service life will vary depending on operation and installation conditions.

Please refer to our website for more information regarding the directions of the allowable moment and overhang load length.

RCP6(S)-SA7R



Model Specification Items

Series	Type	Encoder Type	Motor Type	Lead	Stroke	Applicable Controller/I/O Type	Cable Length	Options
□	SA7R	WA	56P	□	□	□	□	□
RCP6: Separate Controller RCP6S: Built-in Controller		WA: Battery-less Absolute	56P: Stepper Motor 56□ Size	24: 24mm 16: 16mm 8: 8mm 4: 4mm	50: 50mm 800: 800mm (50mm increments)	[RCP6] P3: PCON MCON MSEL P5: RCM-P6PC [RCP6S] SE: SIO Type	N: None P: 1m S: 3m M: 5m X□□: Specified Length R□□: Robot Cable	Please refer to the options table below. * Please make sure to specify either ML or MR when ordering the side-mounted motor type.

* RCP6 does not include a controller. RCP6S includes a built-in controller.
* Please refer to P.15 for more information about the model specification items.

* Body width does not include the width of the side-mounted motor.

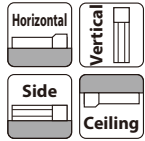

*Some limitations may apply to horizontal/side/ceiling mountings depending on the model. See page 204. Please contact IAI for more information.



The figure above is the motor side-mounted to the left (ML).

	(1) The maximum acceleration/deceleration is 1G for horizontal, and 0.5G for vertical use.
	(2) The actuator specification displays the payload's maximum value, but it will vary depending on the acceleration and speed. Please refer to the "Selection Guidelines" (Tables of Payload by Speed/Acceleration) on P.209 for more details.
	(3) Please refer to P.205 for performing push-motion operation.
	(4) Depending on the ambient operational temperature, duty control is necessary for the RCP6S (built-in controller type) with lead 4/8/16. Please refer to P.247 for more information.

Correlation Diagrams of Speed and Payload

(1) High-output enabled with PCON/MCON/MSEL connected.

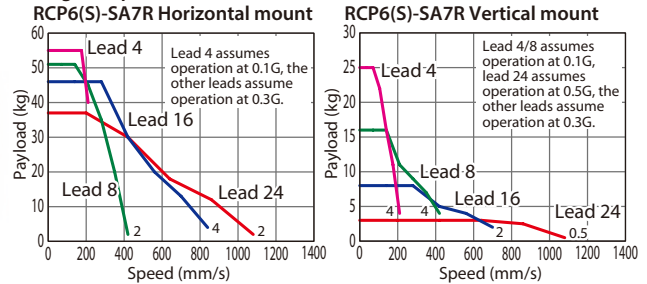

(2) High-output disabled with PCON/MCON connected.

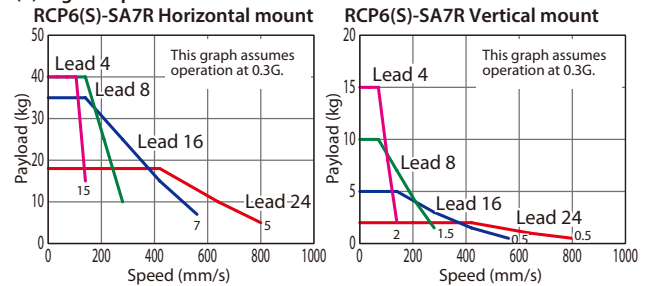

Actuator Specifications

Lead and Payload

* Push force only available during push mode w / limited speed.

Model Number	Lead (mm)	Connected Controller	Max. Payload		Max. Push Force (N)*
			Horizontal (kg)	Vertical (kg)	
RCP6(S)-SA7R-WA-56P-24-①-②-③-④	24	High-output Enabled	37	3	112
		High-output Disabled	18	2	
RCP6(S)-SA7R-WA-56P-16-①-②-③-④	16	High-output Enabled	46	8	168
		High-output Disabled	35	5	
RCP6(S)-SA7R-WA-56P-8-①-②-③-④	8	High-output Enabled	51	16	336
		High-output Disabled	40	10	
RCP6(S)-SA7R-WA-56P-4-①-②-③-④	4	High-output Enabled	55	25	673
		High-output Disabled	40	15	

Legend: ① Stroke ② Applicable controller/I/O type ③ Cable length ④ Options

Stroke and Max. Speed

(Unit: mm/s)

Lead (mm)	Connected Controller	Max. Speed					
		50~500 (Every 50mm)	600 (mm)	650 (mm)	700 (mm)	750 (mm)	800 (mm)
24	High-output Enabled	1,080					
	High-output Disabled	800					
16	High-output Enabled	840<700>	830<700>	720<700>	635	560	500
	High-output Disabled	560					
8	High-output Enabled	420	410	355	315	275	245
	High-output Disabled	280					
4	High-output Enabled	210	205	175	155	135	120
	High-output Disabled	140					

Values in brackets < > are for vertical use.

① Stroke

Stroke (mm)	RCP6	RCP6S	Stroke (mm)	RCP6	RCP6S
50	○	○	450	○	○
100	○	○	500	○	○
150	○	○	550	○	○
200	○	○	600	○	○
250	○	○	650	○	○
300	○	○	700	○	○
350	○	○	750	○	○
400	○	○	800	○	○

④ Options

Name	Option Code	Reference Page
Brake	B	See P.189
Cable exit direction (Outside)	CJO	See P.189
Motor side-mounted to the left	ML	See P.193
Motor side-mounted to the right	MR	See P.193
Non-motor end specification	NM	See P.194
Slider roller specification	SR	See P.195
Slider spacer (*1)	SS	See P.195
Double slider specification (*2)	W	See P.196

(*1) Double slider specification cannot be selected.

(*2) Some leads cannot be selected. (Please see P. 248)

When selecting multiple options, please list them in alphabetical order. (e.g. B-CJB-NM)

③ Cable Length

Cable Type	Cable Code	RCP6			RCP6S
		P3	P5	SE	
Standard	P (1m)	○	○	○	○
	S (3m)	○	○	○	○
	M (5m)	○	○	○	○
	X06 (6m) ~X10 (10m)	○	○	○	○
Specified Length	X11 (11m) ~X15 (15m)	○	○	○	○
	X16 (16m) ~X20 (20m)	○	○	○	○
	R01 (1m) ~R03 (3m)	○	○	○	○
Robot Cable	R04 (4m) ~R05 (5m)	○	○	○	○
	R06 (6m) ~R10 (10m)	○	○	○	○
	R11 (11m) ~R15 (15m)	○	○	○	○
	R16 (16m) ~R20 (20m)	○	○	○	○
		○	○	○	○
		○	○	○	○

* Please refer to P.267 and 283 for more information regarding the maintenance cables.

Actuator Specifications

Item	Description
Drive system	Ball screw φ12mm, rolled C10
Positioning repeatability	±0.01mm
Lost motion	0.1mm or less
Base	Material: Aluminum with white alumite treatment
Static allowable moment	Ma: 115N·m, Mb: 115N·m, Mc: 229N·m
Dynamic allowable moment (*)	Ma: 44.7N·m, Mb: 44.7N·m, Mc: 89.1N·m
Ambient operating temp. & humidity	0~40°C, 85% RH or less (Non-condensing)

* Reference for overhang load length: Ma: 300mm or less, Mb, Mc: 300mm or less

(*) Assumes a standard rated life of 5,000km. The service life will vary depending on operation and installation conditions.

Please refer to our website for more information regarding the directions of the allowable moment and overhang load length.

RCP6(S)-SA8R



Model Specification Items

Series	Type	Encoder Type	Motor Type	Lead	Stroke	Applicable Controller/I/O Type	Cable Length	Options
RCP6: Separate Controller RCP6S: Built-in Controller	SA8R	WA: Battery-less Absolute	56SP: High-thrust Stepper Motor 56□ Size	30: 30mm 20: 20mm 10: 10mm 5: 5mm	50: 50mm 1100: 1,100mm (50mm increments)	[RCP6] P4: PCON-CFB/CGFB [RCP6S] SE: SIO Type	N: None P: 1m S: 3m M: 5m X□□: Specified Length R□□: Robot Cable	Please refer to the options table below. * Please make sure to specify either ML or MR when ordering the side-mounted motor type.

* RCP6 does not include a controller. RCP6S includes a built-in controller.
* Please refer to P.15 for more information about the model specification items.

* Body width does not include the width of the side-mounted motor.

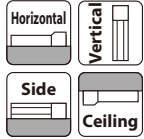

*Some limitations may apply to horizontal/side/ceiling mountings depending on the model. See page 204. Please contact IAI for more information.



The figure above is the motor side-mounted to the left (ML).

POINT Selection Notes

- The maximum acceleration/deceleration is 1G for horizontal, and 0.5G for vertical use.
- The actuator specification displays the payload's maximum value, but it will vary depending on the acceleration and speed. Please refer to the "Selection Guidelines" (Tables of Payload by Speed/Acceleration) on P.209 for more details.
- Please refer to P205 for performing push-motion operation.

Correlation Diagrams of Speed and Payload

PCON connected.

RCP6(S)-SA8R Horizontal mount

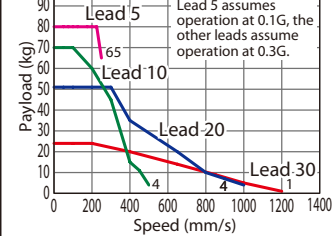

RCP6(S)-SA8R Vertical mount

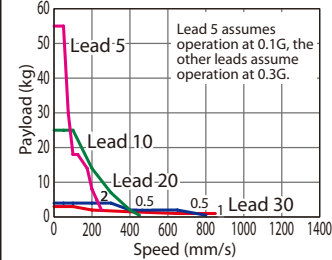

Actuator Specifications

Lead and Payload

* Push force only available during push mode w / limited speed.

Model Number	Lead (mm)	Max. Payload		Max. Push Force (N)*
		Horizontal (kg)	Vertical (kg)	
RCP6(S)-SA8R-WA-56SP-30-①-②-③-④	30	26	3	159
RCP6(S)-SA8R-WA-56SP-20-①-②-③-④	20	55	4	239
RCP6(S)-SA8R-WA-56SP-10-①-②-③-④	10	70	25	478
RCP6(S)-SA8R-WA-56SP-5-①-②-③-④	5	80	55	956

Legend: ① Stroke ② Applicable controller/I/O type ③ Cable length ④ Options

Stroke and Max. Speed

(Unit: mm/s)

Lead (mm)	50~650 (Every 50mm)	700 (mm)	750 (mm)	800 (mm)	850 (mm)	900 (mm)	950 (mm)	1,000 (mm)	1,050 (mm)	1,100 (mm)
30	1,200 <850>		1,155 <850>	1,040 <850>	940 <850>	855 <850>	780	715	660	
20	1,000 <800>	950 <800>	860 <800>	770	695	630	570	520	480	440
10	500 <450>	480 <450>	430	385	345	310	285	260	235	220
5	250	240	215	190	175	155	145	130	120	110

Values in brackets < > are for vertical use.

① Stroke

Stroke (mm)	RCP6	RCP6S	Stroke (mm)	RCP6	RCP6S
50	○	○	600	○	○
100	○	○	650	○	○
150	○	○	700	○	○
200	○	○	750	○	○
250	○	○	800	○	○
300	○	○	850	○	○
350	○	○	900	○	○
400	○	○	950	○	○
450	○	○	1000	○	○
500	○	○	1050	○	○
550	○	○	1100	○	○

③ Cable Length

Cable Type	Cable Code	RCP6	RCP6S
Standard	P (1m)	○	○
	S (3m)	○	○
	M (5m)	○	○
Specified Length	X06 (6m) ~X10 (10m)	○	○
	X11 (11m) ~X15 (15m)	○	○
	X16 (16m) ~X20 (20m)	○	○
	R01 (1m) ~R03 (3m)	○	○
Robot Cable	R04 (4m) ~R05 (5m)	○	○
	R06 (6m) ~R10 (10m)	○	○
	R11 (11m) ~R15 (15m)	○	○
	R16 (16m) ~R20 (20m)	○	○

* Please refer to P.267 and 283 for more information regarding the maintenance cables.

④ Options

Name	Option Code	Reference Page
Brake	B	See P.189
Cable exit direction (Outside)	CJO	See P.189
Motor side-mounted to the left	ML	See P.193
Motor side-mounted to the right	MR	See P.193
Non-motor end specification	NM	See P.194
Slider roller specification	SR	See P.195
Slider spacer (*1)	SS	See P.195
Double slider specification (*2)	W	See P.196

(*1) Double slider specification cannot be selected.

(*2) Some leads cannot be selected. (Please see P. 248)

When selecting multiple options, please list them in alphabetical order. (e.g. B-CJB-NM)

Actuator Specifications

Item	Description
Drive system	Ball screw φ16mm, rolled C10
Positioning repeatability	±0.01mm
Lost motion	0.1mm or less
Base	Material: Aluminum with white alumite treatment
Static allowable moment	Ma: 219N·m, Mb: 219N·m, Mc: 414N·m
Dynamic allowable moment (*)	Ma: 77.0N·m, Mb: 77.0N·m, Mc: 146N·m
Ambient operating temp. & humidity	0~40°C, 85% RH or less (Non-condensing)

* Reference for overhang load length: Ma: 400mm or less, Mb, Mc: 400mm or less

(*) Assumes a standard rated life of 5,000km. The service life will vary depending on operation and installation conditions.

Please refer to our website for more information regarding the directions of the allowable moment and overhang load length.



*1 When the slider is returning to its home position, please be careful of interference from surrounding objects, as it will travel until it reaches the M.E. M.E: Mechanical end S.E: Stroke end

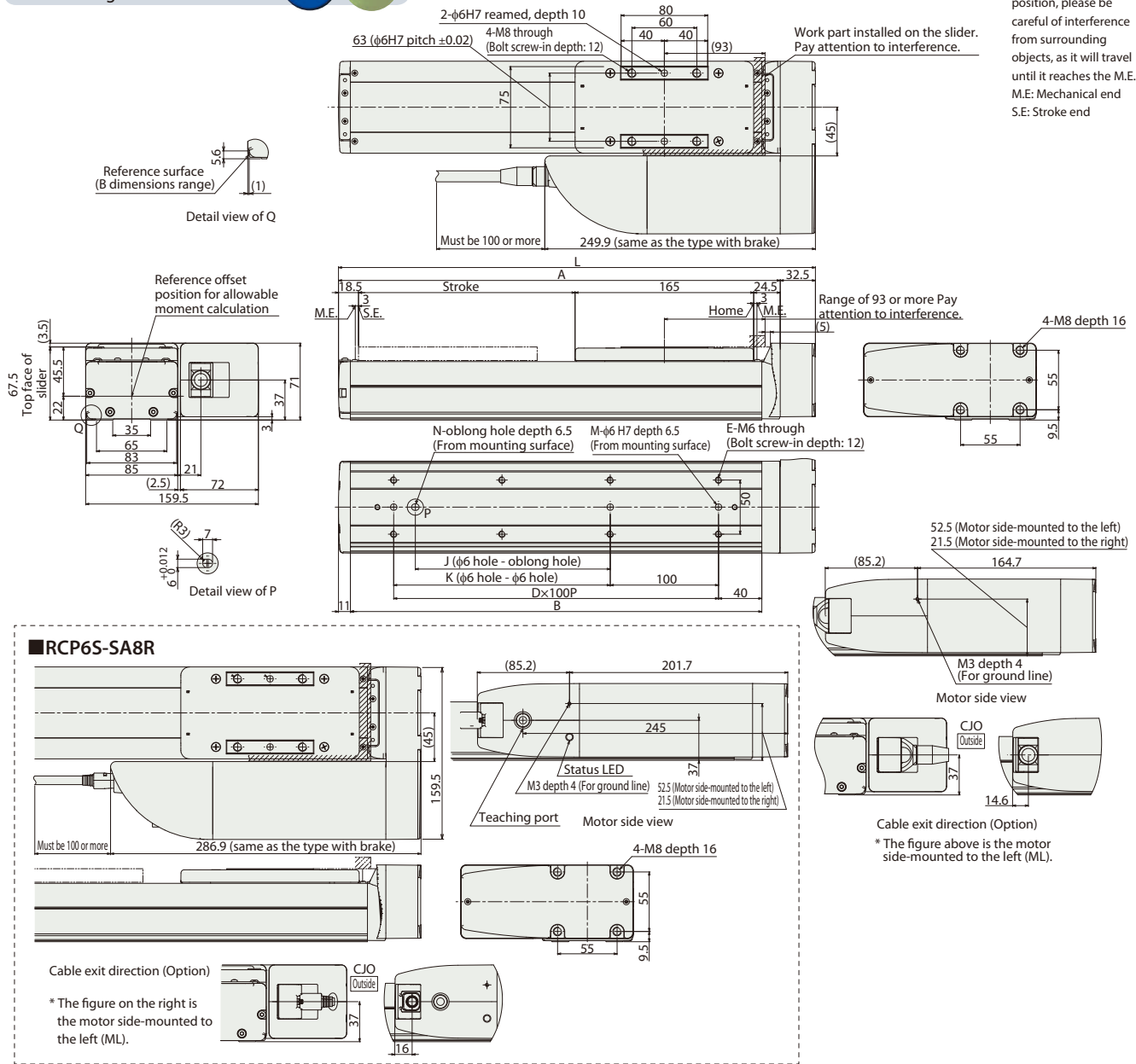

■ Dimensions and Mass by Stroke

Stroke	50	100	150	200	250	300	350	400	450	500	550	600	650	700	750	800	850	900	950	1,000	1,050	1,100		
L	290.5	340.5	390.5	440.5	490.5	540.5	590.5	640.5	690.5	740.5	790.5	840.5	890.5	940.5	990.5	1,040.5	1,090.5	1,140.5	1,190.5	1,240.5	1,290.5	1,340.5		
A	258	308	358	408	458	508	558	608	658	708	758	808	858	908	958	1,008	1,058	1,108	1,158	1,208	1,258	1,308		
B	230	280	330	380	430	480	530	580	630	680	730	780	830	880	930	980	1,030	1,080	1,130	1,180	1,230	1,280		
D	1	2	2	3	3	4	4	5	5	6	6	7	7	8	8	9	9	10	10	11	11	12		
E	4	6	6	8	8	10	10	12	12	14	14	16	16	18	18	20	20	22	22	24	24	26		
J	0	0	80	180	180	280	280	380	380	480	480	580	580	680	680	780	780	880	880	980	980	1,080		
K	0	100	100	200	200	300	300	400	400	500	500	600	600	700	700	800	800	900	900	1,000	1,000	1,100		
M	2	3	3	3	3	3	3	3	3	3	3	3	3	3	3	3	3	3	3	3	3	3		
N	0	0	1	1	1	1	1	1	1	1	1	1	1	1	1	1	1	1	1	1	1	1		
Mass (kg)	RCP6	w/o brake	4.8	5.1	5.4	5.7	5.9	6.2	6.5	6.8	7.1	7.4	7.6	7.9	8.2	8.5	8.8	9.0	9.3	9.6	9.9	10.2	10.5	10.7
		w/ brake	5.0	5.3	5.5	5.8	6.1	6.4	6.7	6.9	7.2	7.5	7.8	8.1	8.4	8.6	8.9	9.2	9.5	9.8	10.1	10.3	10.6	10.9
	RCP6S	w/o brake	4.9	5.2	5.5	5.8	6.1	6.3	6.6	6.9	7.2	7.5	7.8	8.0	8.3	8.6	8.9	9.2	9.4	9.7	10.0	10.3	10.6	10.9
		w/ brake	5.1	5.4	5.7	5.9	6.2	6.5	6.8	7.1	7.3	7.6	7.9	8.2	8.5	8.8	9.0	9.3	9.6	9.9	10.2	10.5	10.7	11.0

② Applicable Controllers

The RCP6 series actuators can be operated by the controllers indicated below. Please select the type depending on your intended use. * Please refer to P.271 for more information about the built-in controller of RCP6S series.

Name	External view	Max. number of controlled axes	Input power	Control method				Maximum number of positioning points	Reference page
				Positioner	Pulse train	Program	Network *Option		
PCON-CFB/CGFB		1	DC24V	*Option	*Option	-	DeviceNet CompoNet EtherNet/IP CC-Link MECHATROLINK EtherCAT PROFINET	512 (768 for network spec.)	Please see P.255

Foreword
Slider Type
Wide Slider Type
Rod Type
Radial Cylinder
Wide Radial Cylinder
Table Type
Cleanroom Slider
Cleanroom Wide Slider
Dust/Splash-Proof Rod
Dust/Splash-Proof Radial Cylinder*
Dust/Splash-Proof Wide Radial Cylinder
Options
Reference Data
Controller

RCP6(S)-WSA10C



Model Specification Items

Series	Type	Encoder Type	Motor Type	Lead	Stroke	Applicable Controller/I/O Type	Cable Length	Options
RCP6: Separate Controller RCP6S: Built-in Controller	WSA10C	WA: Battery-less Absolute	35P: Stepper Motor 35□ Size	16: 16mm 10: 10mm 5: 5mm 2.5: 2.5mm	50: 50mm 500: 500mm (50mm increments)	RCP6 P3: PCON MCON MSEL P5: RCM-P6PC RCP6S SE: SIO Type	N: None P: 1m S: 3m M: 5m X□□: Specified Length R□□: Robot Cable	Please refer to the options table below.

* RCP6 does not include a controller. RCP6S includes a built-in controller.
* Please refer to P.15 for more information about the model specification items.

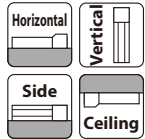

*Some limitations may apply to horizontal/side/ceiling mountings depending on the model. See page 204. Please contact IAI for more information.

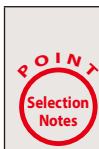
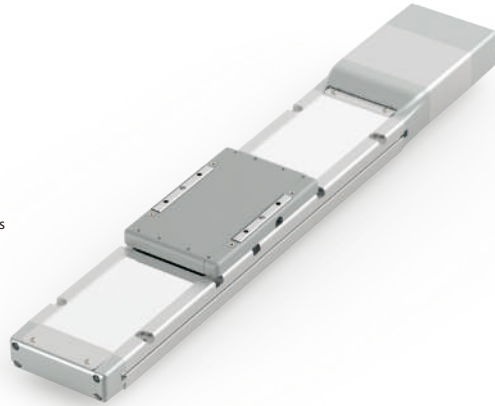

- The maximum acceleration/deceleration is 1G for horizontal, and 0.5G for vertical use.
- The actuator specification displays the payload's maximum value, but it will vary depending on the acceleration and speed. Please refer to the "Selection Guidelines" (Tables of Payload by Speed/Acceleration) on P.211 for more details.
- Please refer to P.205 for performing push-motion operation.

Correlation Diagrams of Speed and Payload

(1) High-output enabled with PCON/MCON/MSEL connected.

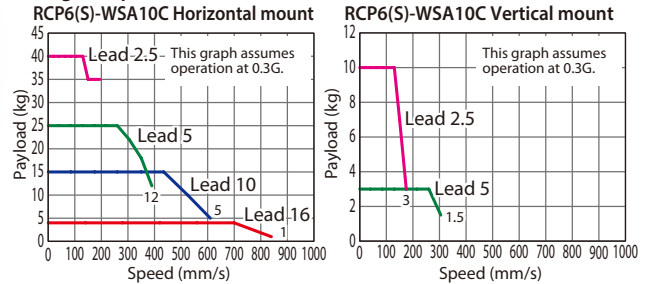

(2) High-output disabled with PCON/MCON connected.

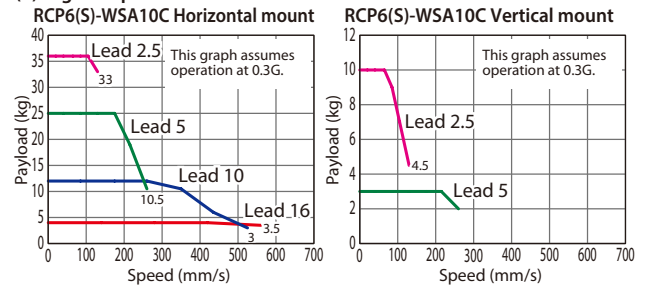

Actuator Specifications

Lead and Payload

* Push force only available during push mode w / limited speed.

Model Number	Lead (mm)	Connected Controller	Max. Payload		Max Push Force (N)*
			Horizontal (kg)	Vertical (kg)	
RCP6(S)-WSA10C-WA-35P-16-①-②-③-④	16	High-output Enabled	4	—	48
		High-output Disabled	4	—	
RCP6(S)-WSA10C-WA-35P-10-①-②-③-④	10	High-output Enabled	15	—	77
		High-output Disabled	12	—	
RCP6(S)-WSA10C-WA-35P-5-①-②-③-④	5	High-output Enabled	28	3	155
		High-output Disabled	25	3	
RCP6(S)-WSA10C-WA-35P-2.5-①-②-③-④	2.5	High-output Enabled	40	10	310
		High-output Disabled	36	10	

Legend: ① Stroke ② Applicable controller/I/O type ③ Cable length ④ Options

Stroke and Max. Speed

(Unit: mm/s)

Lead (mm)	Connected Controller	Max. Speed			
		50~300 (Every 50mm)	350 (mm)	400 (mm)	450 (mm)
16	High-output Enabled	840	775	660	
	High-output Disabled	560			
10	High-output Enabled	610	590	490	415
	High-output Disabled	525			
5	High-output Enabled	390<350>	355<350>	290	245
	High-output Disabled	260		245	205
2.5	High-output Enabled	195<175>	175	145	120
	High-output Disabled	130		120	100

Values in brackets < > are for vertical use.

① Stroke

Stroke (mm)	RCP6	RCP6S	Stroke (mm)	RCP6	RCP6S
50	○	○	300	○	○
100	○	○	350	○	○
150	○	○	400	○	○
200	○	○	450	○	○
250	○	○	500	○	○

④ Options

Name	Option Code	Reference Page
Brake	B	See P.189
Cable exit direction (Top)	CJT	See P.189
Cable exit direction (Right)	CJR	See P.189
Cable exit direction (Left) (*1)	CJL	See P.189
Cable exit direction (Bottom)	CJB	See P.189
Designated grease coating specification	G1/G3/G4	
High-Precision Specification (*2)	HPR	See P.192
Non-motor end specification	NM	See P.194
Slider roller specification	SR	See P.195

(*1) RCP6S cannot be selected.

(*2) When the lead is 16, it cannot be selected.

When selecting multiple options, please list them in alphabetical order. (e.g. B-CJB-NM)

③ Cable Length

Cable Type	Cable Code	RCP6			RCP6S
		P3	P5	SE	
Standard	P (1m)	○	○	○	○
	S (3m)	○	○	○	○
	M (5m)	○	○	○	○
Specified Length	X06 (6m) ~X10 (10m)	○	○	○	○
	X11 (11m) ~X15 (15m)	○	○	○	○
	X16 (16m) ~X20 (20m)	○	○	○	○
	R01 (1m) ~R03 (3m)	○	○	○	○
Robot Cable	R04 (4m) ~R05 (5m)	○	○	○	○
	R06 (6m) ~R10 (10m)	○	○	○	○
	R11 (11m) ~R15 (15m)	○	○	○	○
	R16 (16m) ~R20 (20m)	○	○	○	○

* Please refer to P.267 and 283 for more information regarding the maintenance cables.

Actuator Specifications

Item	Description
Drive system	Ball screw φ8mm, rolled C10
Positioning repeatability (*1)	±0.01mm [±0.005mm]
Lost motion	0.1mm or less
Base	Material: Aluminum with white alumite treatment
Static allowable moment	Ma: 271N·m, Mb: 271N·m, Mc: 553N·m
Dynamic allowable moment (*2)	Ma: 65.4N·m, Mb: 65.4N·m, Mc: 134N·m
Ambient operating temp. & humidity	0~40°C, 85% RH or less (Non-condensing)

* Reference for overhang load length: Ma: 500mm or less, Mb, Mc: 500mm or less

(*1) Values in [] are for high-precision (for lead 2.5/5/10) specification.

(*2) Assumes a standard rated life of 5,000km. The service life will vary depending on operation and installation conditions. Please refer to our website for more information regarding the directions of the allowable moment and overhang load length.



*1 When the slider is returning to its home position, please be careful of interference from surrounding objects, as it will travel until it reaches the M.E.
M.E: Mechanical end S.E: Stroke end

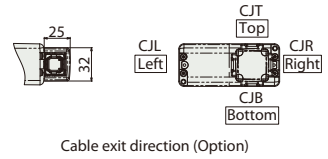
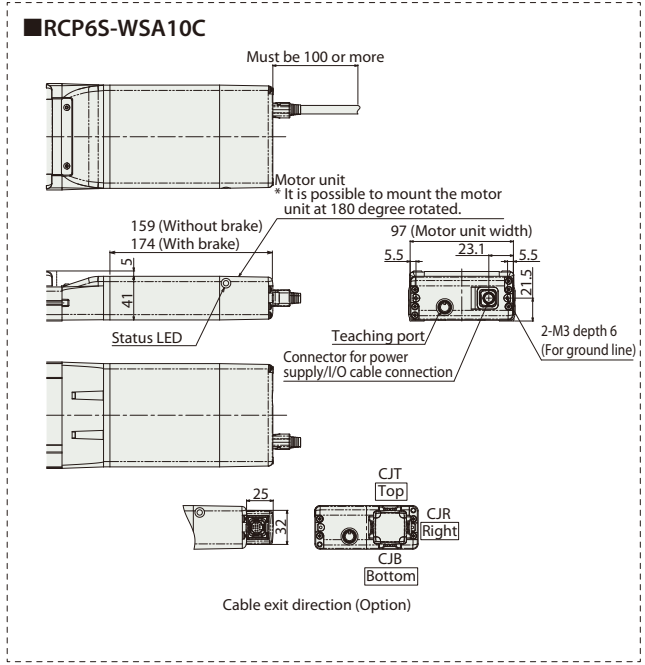
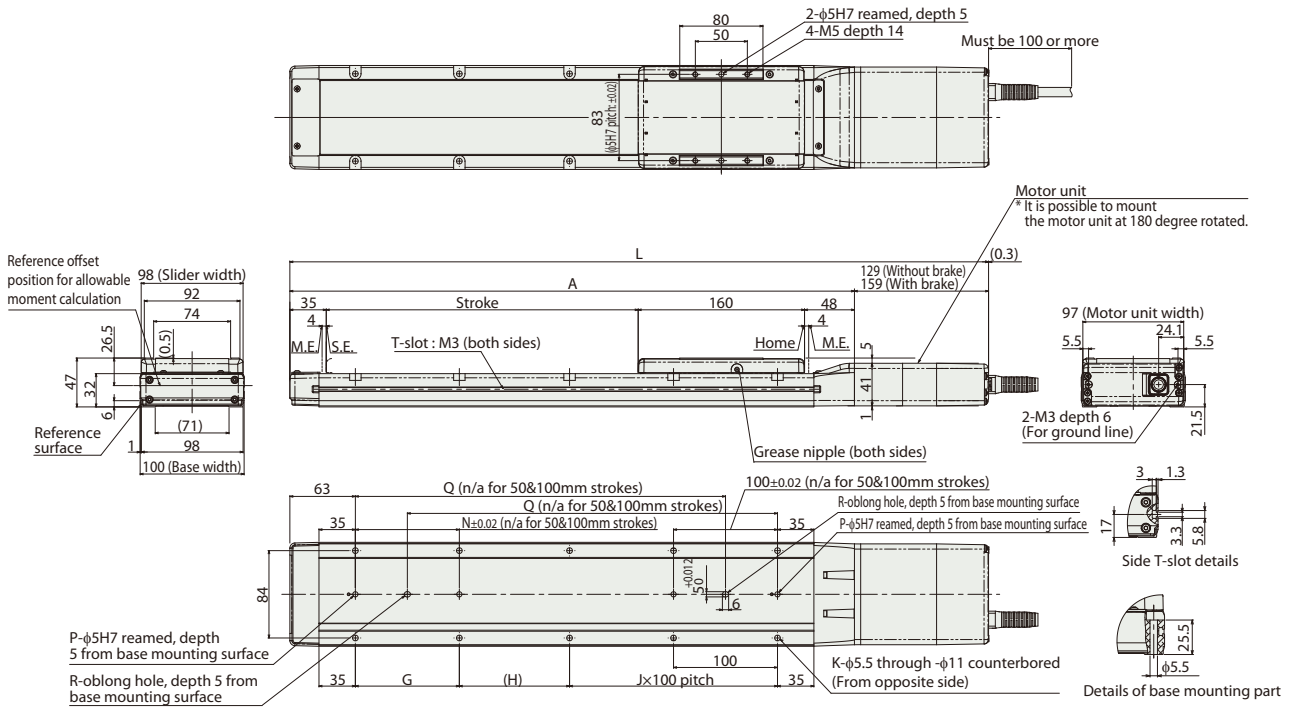

Dimensions and Mass by Stroke

L	Stroke	Stroke									
		50	100	150	200	250	300	350	400	450	500
RCP6	w/o brake	422	472	522	572	622	672	722	772	822	872
	w/brake	452	502	552	602	652	702	752	802	852	902
RCP6S	w/o brake	452	502	552	602	652	702	752	802	852	902
	w/brake	467	517	567	617	667	717	767	817	867	917
A		293	343	393	443	493	543	593	643	693	743
G		-	-	100	100	100	100	100	100	100	100
H		156	206	56	106	56	106	56	106	56	106
J		0	0	1	1	2	2	3	3	4	4
K		4	4	8	8	10	10	12	12	14	14
N		-	-	100	100	100	100	100	100	100	100
P		1	1	2	2	2	2	2	2	2	2
Q		-	-	206	256	306	356	406	456	506	556
R		0	0	1	1	1	1	1	1	1	1
Mass (kg)	RCP6 w/o brake	2.9	3.1	3.4	3.6	3.8	4.1	4.3	4.6	4.8	5.0
	RCP6 w/brake	3.1	3.3	3.6	3.8	4.0	4.3	4.5	4.8	5.0	5.2
RCP6S	w/o brake	3.0	3.2	3.5	3.7	3.9	4.2	4.4	4.7	4.9	5.1
	w/brake	3.1	3.4	3.6	3.9	4.1	4.3	4.6	4.8	5.1	5.3

② Applicable Controllers

The RCP6 series actuators can be operated by the controllers indicated below. Please select the type depending on your intended use. * Please refer to P.271 for more information about the built-in controller of RCP6S series.

Name	External view	Max. number of controlled axes	Input power	Control method				Maximum number of positioning points	Reference page
				Positioner	Pulse train	Program	Network * Option		
PCON-CYB/PLB/POB		1	DC24V	●	●	-	Network cannot be selected	64	Please contact IAI for more information.
PCON-CB/CGB		1		* Option	* Option	-	DeviceNet, MECHATROLINK, CC-Link, EtherCAT, EtherNet/IP, CANopen	512 (768 for network spec.)	Please see P.255
MCON-C/CG		8		This model is network-compatible only.				256	Please contact IAI for more information.
MCON-LC/LCG		6		-	-	●	CompoNet, SSCNET III/H	256	Please contact IAI for more information.
MSEL-PC/PG		4	Single-phase 100 ~ 230 VAC	-	-	●	Note: The type of compatible networks will vary depending on the controller. Please refer to reference page for more information.	30,000	Please contact IAI for more information.
RCM-P6PC		1		Usable within the RCP6S Gateway system.				768	Please see P.279

* For the MCON controller, high-output enabled operation is only available if "high-output setting" is selected as an option. The maximum connectable axes with high-output enabled are C: 4 and LC: 3.

Foreword
Slider Type
Wide Slider Type
Rod Type
Radial Cylinder
Wide Radial Cylinder
Table Type
Cleanroom Slider
Cleanroom Wide Slider
Dust/Splash-Proof Rod
Dust/Splash-Proof Radial Cylinder
Dust/Splash-Proof Wide Radial Cylinder
Options
Reference Data
Controller

RCP6(S)-WSA12C



Model Specification Items

Series	Type	Encoder Type	Motor Type	Lead	Stroke	Applicable Controller/I/O Type	Cable Length	Options
RCP6: Separate Controller RCP6S: Built-in Controller	WSA12C	WA: Battery-less Absolute	42P: Stepper Motor 42□ Size	20: 20mm 12: 12mm 6: 6mm 3: 3mm	50: 50mm 800: 800mm (50mm increments)	[RCP6] P3: PCON MCON MSEL P5: RCM-P6PC [RCP6S] SE: SIO Type	N: None P: 1m S: 3m M: 5m □□□: Specified Length R□□: Robot Cable	Please refer to the options table below.

* RCP6 does not include a controller. RCP6S includes a built-in controller.
* Please refer to P.15 for more information about the model specification items.

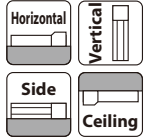

*Some limitations may apply to horizontal/side/ceiling mountings depending on the model. See page 204. Please contact IAI for more information.

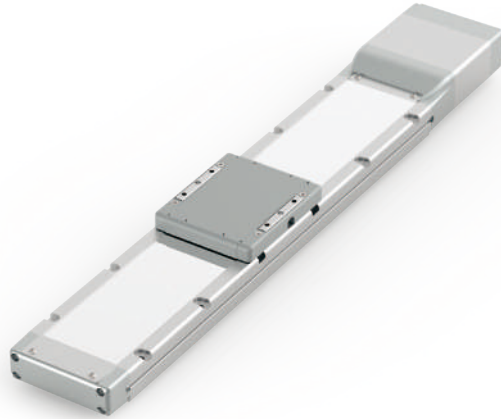

- POINT Selection Notes**
- (1) The maximum acceleration/deceleration is 1G for horizontal, and 0.5G for vertical use.
 - (2) The actuator specification displays the payload's maximum value, but it will vary depending on the acceleration and speed. Please refer to the "Selection Guidelines" (Tables of Payload by Speed/Acceleration) on P.211 for more details.
 - (3) Please refer to P.205 for performing push-motion operation.
 - (4) Depending on the ambient operational temperature, duty control is necessary for the RCP6S (built-in controller type) with lead 3/6. Please refer to P.247 for more information.

Correlation Diagrams of Speed and Payload

(1) High-output enabled with PCON/MCON/MSEL connected.

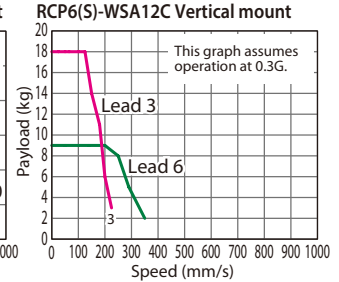
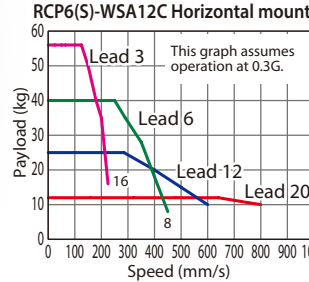

(2) High-output disabled with PCON/MCON connected.

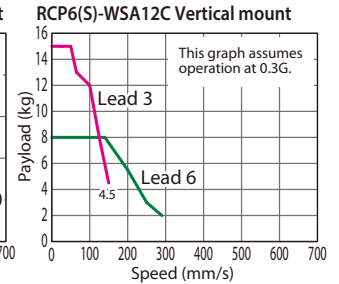
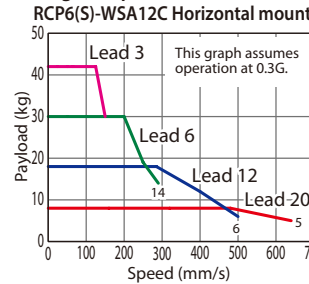

Actuator Specifications

Lead and Payload

* Push force only available during push mode w / limited speed.

Model Number	Lead (mm)	Connected Controller	Max. Payload		Max. Push Force (N)*
			Horizontal (kg)	Vertical (kg)	
RCP6(S)-WSA12C-WA-42P-20-①-②-③-④	20	High-output Enabled	12	-	56
		High-output Disabled	8	-	
RCP6(S)-WSA12C-WA-42P-12-①-②-③-④	12	High-output Enabled	25	-	93
		High-output Disabled	18	-	
RCP6(S)-WSA12C-WA-42P-6-①-②-③-④	6	High-output Enabled	40	9	185
		High-output Disabled	30	8	
RCP6(S)-WSA12C-WA-42P-3-①-②-③-④	3	High-output Enabled	60	18	370
		High-output Disabled	42	15	

Legend: ① Stroke ② Applicable controller/I/O type ③ Cable length ④ Options

Stroke and Max. Speed

(Unit: mm/s)

Lead (mm)	Connected Controller	Max. Speed									
		50~350 (Every 50mm)	400	450	500	550	600	650	700	750	800
20	High-output Enabled	800		740		650		580		520	
	High-output Disabled	640		580		520		460		400	
12	High-output Enabled	600		535		465		405		315	
	High-output Disabled	500		465		405		355		285	
6	High-output Enabled	450<400>	435<400>	365	310	265	230	200	175	155	140
	High-output Disabled	290		265		230		200		175	
3	High-output Enabled	225	215	180	150	130	115	100	85	75	70
	High-output Disabled	150		130		115		100		85	

Values in brackets < > are for vertical use.

① Stroke

Stroke (mm)	RCP6	RCP6S	Stroke (mm)	RCP6	RCP6S
50	○	○	450	○	○
100	○	○	500	○	○
150	○	○	550	○	○
200	○	○	600	○	○
250	○	○	650	○	○
300	○	○	700	○	○
350	○	○	750	○	○
400	○	○	800	○	○

④ Options

Name	Option Code	Reference Page
Brake	B	See P.189
Cable exit direction (Top)	CJT	See P.189
Cable exit direction (Right)	CJR	See P.189
Cable exit direction (Left)	CJL	See P.189
Cable exit direction (Bottom)	CJB	See P.189
Designated grease coating specification	G1/G3/G4	
High-Precision Specification *	HPR	See P.192
Non-motor end specification	NM	See P.194
Slider roller specification	SR	See P.195

* When the lead is 20, it cannot be selected.

When selecting multiple options, please list them in alphabetical order. (e.g. B-CJB-NM)

③ Cable Length

Cable Type	Cable Code	RCP6			RCP6S
		P3	P5	SE	
Standard	P (1m)	○	○	○	
	S (3m)	○	○	○	
	M (5m)	○	○	○	
Specified Length	X06 (6m) ~X10 (10m)	○	○	○	
	X11 (11m) ~X15 (15m)	○	○	○	
	X16 (16m) ~X20 (20m)	○	○	○	
	R01 (1m) ~R03 (3m)	○	○	○	
Robot Cable	R04 (4m) ~R05 (5m)	○	○	○	
	R06 (6m) ~R10 (10m)	○	○	○	
	R11 (11m) ~R15 (15m)	○	○	○	
	R16 (16m) ~R20 (20m)	○	○	○	
		○	○	○	
		○	○	○	

* Please refer to P.267 and 283 for more information regarding the maintenance cables.

Actuator Specifications

Item	Description
Drive system	Ball screw φ10mm, rolled C10
Positioning repeatability (*1)	±0.01mm [±0.005mm]
Lost motion	0.1mm or less
Base	Material: Aluminum with white alumite treatment
Static allowable moment	Ma: 311N·m, Mb: 311N·m, Mc: 827N·m
Dynamic allowable moment (*2)	Ma: 87.5N·m, Mb: 87.5N·m, Mc: 233N·m
Ambient operating temp. & humidity	0~40°C, 85% RH or less (Non-condensing)

* Reference for overhang load length: Ma: 450mm or less, Mb, Mc: 450mm or less

(*1) Values in [] are for high-precision (for lead 3/6/12) specification.

(*2) Assumes a standard rated life of 5,000km. The service life will vary depending on operation and installation conditions. Please refer to our website for more information regarding the directions of the allowable moment and overhang load length.

RCP6(S)-WSA14C



Model Specification Items

Series	Type	Encoder Type	Motor Type	Lead	Stroke	Applicable Controller/I/O Type	Cable Length	Options
RCP6: Separate Controller RCP6S: Built-in Controller	WSA14C	WA: Battery-less Absolute	56P: Stepper Motor 56□ Size	24: 24mm 16: 16mm 8: 8mm 4: 4mm	50: 50mm 800: 800mm (50mm increments)	[RCP6] P3: PCON MCON MSEL P5: RCM-P6PC [RCP6S] SE: SIO Type	N: None P: 1m S: 3m M: 5m □□□: Specified Length RC□□: Robot Cable	Please refer to the options table below.

* RCP6 does not include a controller. RCP6S includes a built-in controller.
* Please refer to P.15 for more information about the model specification items.

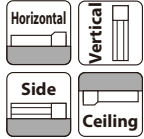

*Some limitations may apply to horizontal/side/ceiling mountings depending on the model. See page 204. Please contact IAI for more information.



- The maximum acceleration/deceleration is 1G for horizontal, and 0.5G for vertical use.
- The actuator specification displays the payload's maximum value, but it will vary depending on the acceleration and speed. Please refer to the "Selection Guidelines" (Tables of Payload by Speed/Acceleration) on P.211 for more details.
- Please refer to P.205 for performing push-motion operation.
- Depending on the ambient operational temperature, duty control is necessary for the RCP6S (built-in controller type) with lead 4/8/16. Please refer to P.247 for more information.

Correlation Diagrams of Speed and Payload

(1) High-output enabled with PCON/MCON/MSEL connected.

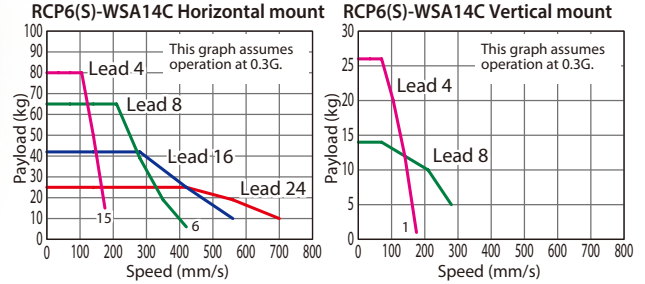

(2) High-output disabled with PCON/MCON connected.

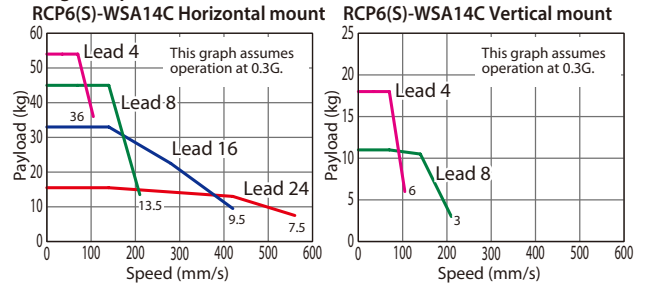

Actuator Specifications

Lead and Payload

* Push force only available during push mode w / limited speed.

Model Number	Lead (mm)	Connected Controller	Max. Payload		Max. Push Force (N)*
			Horizontal (kg)	Vertical (kg)	
RCP6(S)-WSA14C-WA-56P-24-①-②-③-④	24	High-output Enabled	25	—	112
		High-output Disabled	15.5	—	
RCP6(S)-WSA14C-WA-56P-16-①-②-③-④	16	High-output Enabled	50	—	168
		High-output Disabled	33	—	
RCP6(S)-WSA14C-WA-56P-8-①-②-③-④	8	High-output Enabled	65	14	336
		High-output Disabled	45	11	
RCP6(S)-WSA14C-WA-56P-4-①-②-③-④	4	High-output Enabled	80	26	673
		High-output Disabled	54	18	

Legend: ① Stroke ② Applicable controller/I/O type ③ Cable length ④ Options

Stroke and Max. Speed

(Unit: mm/s)

Lead (mm)	Connected Controller	Max. Speed						
		50~500 (Every 50mm)	550 (mm)	600 (mm)	650 (mm)	700 (mm)	750 (mm)	800 (mm)
24	High-output Enabled	700						
	High-output Disabled	560						
16	High-output Enabled	560						
	High-output Disabled	420						
8	High-output Enabled	420<350>	400<350>	350	305	270	240	215
	High-output Disabled	210						
4	High-output Enabled	210<175>	200<175>	170	150	135	120	105
	High-output Disabled	105						

Values in brackets < > are for vertical use.

① Stroke

Stroke (mm)	RCP6	RCP6S	Stroke (mm)	RCP6	RCP6S
50	○	○	450	○	○
100	○	○	500	○	○
150	○	○	550	○	○
200	○	○	600	○	○
250	○	○	650	○	○
300	○	○	700	○	○
350	○	○	750	○	○
400	○	○	800	○	○

④ Options

Name	Option Code	Reference Page
Brake	B	See P.189
Cable exit direction (Top)	CJT	See P.189
Cable exit direction (Right)	CJR	See P.189
Cable exit direction (Left)	CJL	See P.189
Cable exit direction (Bottom)	CJB	See P.189
Designated grease coating specification	G1/G3/G4	
High-Precision Specification *	HPR	See P.192
Non-motor end specification	NM	See P.194
Slider roller specification	SR	See P.195

* When the lead is 16/24, it cannot be selected.

When selecting multiple options, please list them in alphabetical order. (e.g. B-CJB-NM)

③ Cable Length

Cable Type	Cable Code	RCP6			RCP6S
		P3	P5	SE	
Standard	P (1m)	○	○	○	○
	S (3m)	○	○	○	○
	M (5m)	○	○	○	○
Specified Length	X06 (6m) ~X10 (10m)	○	○	○	○
	X11 (11m) ~X15 (15m)	○	○	○	○
	X16 (16m) ~X20 (20m)	○	○	○	○
	R01 (1m) ~R03 (3m)	○	○	○	○
Robot Cable	R04 (4m) ~R05 (5m)	○	○	○	○
	R06 (6m) ~R10 (10m)	○	○	○	○
	R11 (11m) ~R15 (15m)	○	○	○	○
	R16 (16m) ~R20 (20m)	○	○	○	○

* Please refer to P.267 and 283 for more information regarding the maintenance cables.

Actuator Specifications

Item	Description
Drive system	Ball screw φ12mm, rolled C10
Positioning repeatability (*1)	±0.01mm [±0.005mm]
Lost motion	0.1mm or less
Base	Material: Aluminum with white alumite treatment
Static allowable moment	Ma: 462N·m, Mb: 462N·m, Mc: 1,170N·m
Dynamic allowable moment (*2)	Ma: 122N·m, Mb: 122N·m, Mc: 308N·m
Ambient operating temp. & humidity	0~40°C, 85% RH or less (Non-condensing)

* Reference for overhang load length: Ma: 550mm or less, Mb, Mc: 550mm or less

(*1) Values in [] are for high-precision (for lead 4/8) specification.

(*2) Assumes a standard rated life of 5,000km. The service life will vary depending on operation and installation conditions. Please refer to our website for more information regarding the directions of the allowable moment and overhang load length.



*1 When the slider is returning to its home position, please be careful of interference from surrounding objects, as it will travel until it reaches the M.E.
M.E: Mechanical end S.E: Stroke end

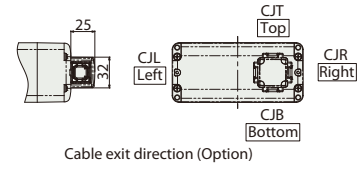
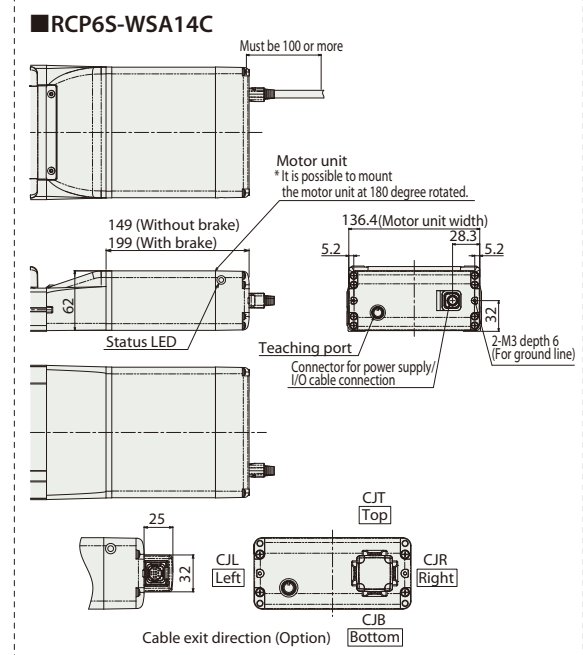
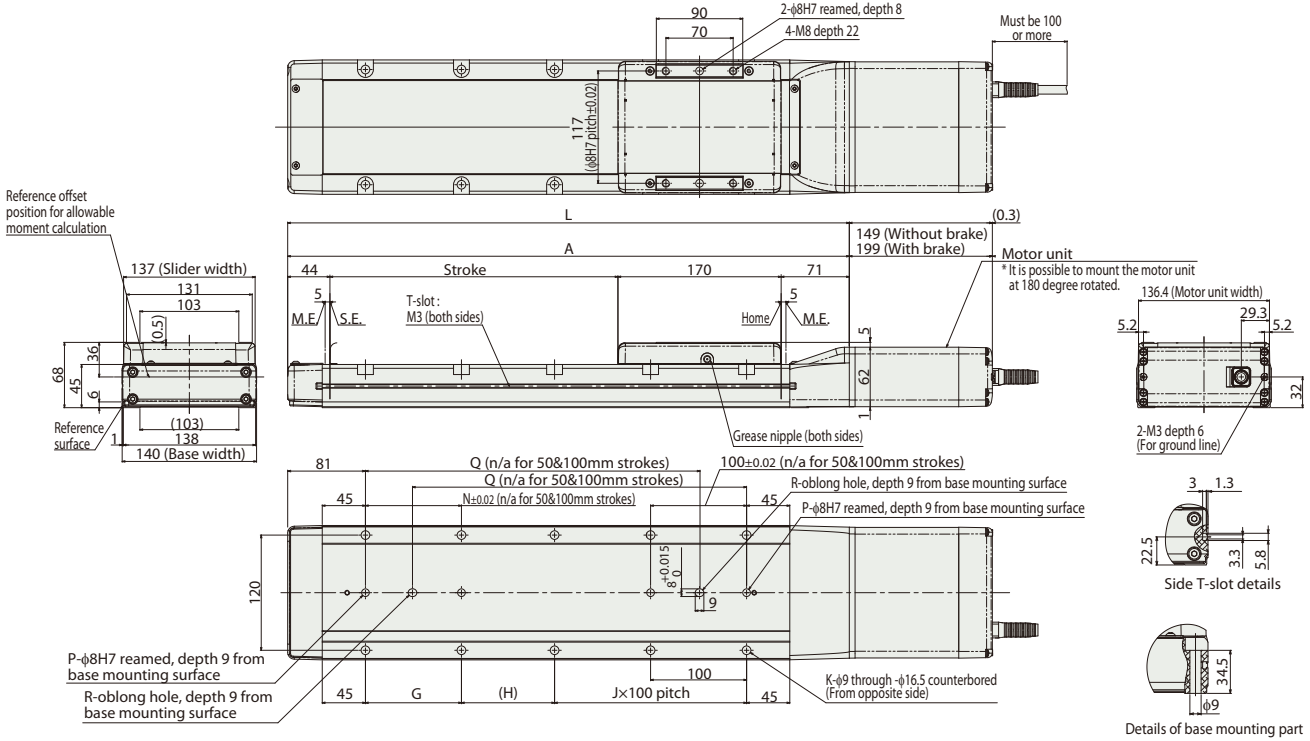

■ Dimensions and Mass by Stroke

Stroke	50	100	150	200	250	300	350	400	450	500	550	600	650	700	750	800	
L	RCP6 w/o brake	484	534	584	634	684	734	784	834	884	934	984	1,034	1,084	1,134	1,184	1,234
	RCP6S w/o brake	534	584	634	684	734	784	834	884	934	984	1,034	1,084	1,134	1,184	1,234	1,284
A	RCP6 w/o brake	484	534	584	634	684	734	784	834	884	934	984	1,034	1,084	1,134	1,184	1,234
	RCP6S w/o brake	534	584	634	684	734	784	834	884	934	984	1,034	1,084	1,134	1,184	1,234	1,284
G	-	-	100	100	100	100	100	100	100	100	100	100	100	100	100	100	100
H	147	197	47	97	47	97	47	97	47	97	47	97	47	97	47	97	47
J	0	0	1	1	2	2	3	3	4	4	5	5	6	6	7	7	2
K	4	4	8	8	10	10	12	12	14	14	16	16	18	18	20	20	20
N	-	-	100	100	100	100	100	100	100	100	100	100	100	100	100	100	100
P	1	1	2	2	2	2	2	2	2	2	2	2	2	2	2	2	2
Q	-	-	198	248	298	348	398	448	498	548	598	648	698	748	798	848	848
R	0	0	1	1	1	1	1	1	1	1	1	1	1	1	1	1	1
Mass (kg)	RCP6 w/o brake	6.6	7.0	7.5	8.0	8.5	8.9	9.4	9.9	10.4	10.9	11.3	11.8	12.3	12.8	13.2	13.7
	RCP6S w/o brake	7.0	7.5	8.0	8.5	8.9	9.4	9.9	10.4	10.9	11.3	11.8	12.3	12.8	13.2	13.7	14.2
w/brake	RCP6	6.6	7.1	7.6	8.0	8.5	9.0	9.5	9.9	10.4	10.9	11.4	11.9	12.3	12.8	13.3	13.8
	RCP6S	7.1	7.6	8.0	8.5	9.0	9.5	9.9	10.4	10.9	11.4	11.8	12.3	12.8	13.3	13.8	14.2

② Applicable Controllers

The RCP6 series actuators can be operated by the controllers indicated below. Please select the type depending on your intended use. * Please refer to P.271 for more information about the built-in controller of RCP6S series.

Name	External view	Max. number of controlled axes	Input power	Control method				Maximum number of positioning points	Reference page
				Positioner	Pulse train	Program	Network * Option		
PCON-CYB/PLB/POB		1	DC24V	●	●	-	Network cannot be selected	64	Please contact IAI for more information.
PCON-CB/CGB		1		* Option	* Option	-	 This model is network-compatible only.	512	Please see P.255 (768 for network spec.)
MCON-C/CG		8		-	-	●		256	
MCON-LC/LCG		6		-	-	●	256	Please contact IAI for more information.	
MSEL-PC/PG		4	Single-phase 100 ~ 230 VAC	-	-	●	30,000	Please contact IAI for more information.	
RCM-P6PC		1	Usable within the RCP6S Gateway system.				768	Please see P.279	

* For the MCON controller, high-output enabled operation is only available if "high-output setting" is selected as an option. The maximum connectable axes with high-output enabled are C: 4 and LC: 3.

Foreword
Slider Type
Wide Slider Type
Rod Type
Radial Cylinder
Wide Radial Cylinder
Table Type
Cleanroom Slider
Cleanroom Wide Slider
Dust/Splash-Proof Rod
Dust/Splash-Proof Radial Cylinder*
Dust/Splash-Proof Wide Radial Cylinder
Options
Reference Data
Controller

RCP6(S)-WSA16C



Model Specification Items

Series	Type	Encoder Type	Motor Type	Lead	Stroke	Applicable Controller/I/O Type	Cable Length	Options
RCP6: Separate Controller RCP6S: Built-in Controller	WSA16C	WA	56SP	20:20mm 10:10mm 5: 5mm	50: 50mm 1100: 1,100mm (50mm increments)	[RCP6] P4: PCON- CFB/CGFB [RCP6S] SE: SIO Type	N : None P : 1m S : 3m M : 5m X□ : Specified Length R□ : Robot Cable	Please refer to the options table below.

* RCP6 does not include a controller. RCP6S includes a built-in controller.
* Please refer to P.15 for more information about the model specification items.

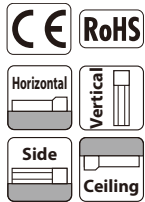

*Some limitations may apply to horizontal/side/ceiling mountings depending on the model. See page 204. Please contact IAI for more information.

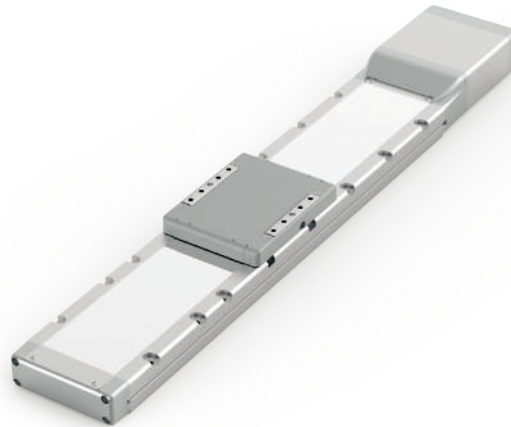

POINT Selection Notes

- (1) The maximum acceleration/deceleration is 1G for horizontal, and 0.5G for vertical use.
- (2) The actuator specification displays the payload's maximum value, but it will vary depending on the acceleration and speed. Please refer to the "Selection Guidelines" (Tables of Payload by Speed/Acceleration) on P.211 for more details.
- (3) Please refer to P.205 for performing push-motion operation.
- (4) The service life of an actuator with lead 5 varies depending on the payload when using vertically. Please refer to P. 206 for more information.

Correlation Diagrams of Speed and Payload

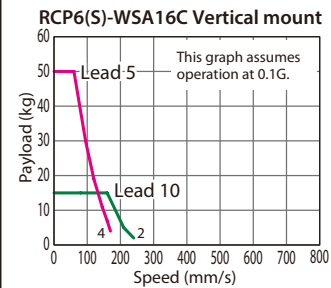
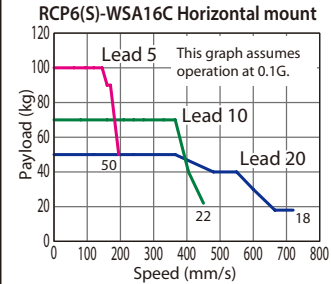

Actuator Specifications

Lead and Payload

* Push force only available during push mode w / limited speed.

Model Number	Lead (mm)	Max. Payload		Max. Push Force (N)*
		Horizontal (kg)	Vertical (kg)	
RCP6(S)-WSA16C-WA-56SP-20-①-②-③-④	20	50	-	239
RCP6(S)-WSA16C-WA-56SP-10-①-②-③-④	10	70	15	478
RCP6(S)-WSA16C-WA-56SP-5-①-②-③-④	5	100	50	956

Legend: ① Stroke ② Applicable controller/I/O type ③ Cable length ④ Options

Stroke and Max. Speed

(Unit: mm/s)

Lead (mm)	Max. Speed (mm/s)									
	50~650 (Every 50mm)	700 (mm)	750 (mm)	800 (mm)	850 (mm)	900 (mm)	950 (mm)	1,000 (mm)	1,050 (mm)	1,100 (mm)
20	720		715	645	590	535	490	450	415	
10	450 <240>	440 <240>	395 <240>	355 <240>	320 <240>	290 <240>	265 <240>	240	225	205
5	195 <170>		175 <170>	160	145	130	120	110	100	

Values in brackets < > are for vertical use.

① Stroke

Stroke (mm)	RCP6	RCP6S	Stroke (mm)	RCP6	RCP6S
50	○	○	600	○	○
100	○	○	650	○	○
150	○	○	700	○	○
200	○	○	750	○	○
250	○	○	800	○	○
300	○	○	850	○	○
350	○	○	900	○	○
400	○	○	950	○	○
450	○	○	1000	○	○
500	○	○	1050	○	○
550	○	○	1100	○	○

④ Options

Name	Option Code	Reference Page
Brake	B	See P.189
Cable exit direction (Top)	CJT	See P.189
Cable exit direction (Right)	CJR	See P.189
Cable exit direction (Left)	CJL	See P.189
Cable exit direction (Bottom)	CJB	See P.189
Designated grease coating specification	G1/G3/G4	
High-Precision Specification *	HPR	See P.192
Non-motor end specification	NM	See P.194
Slider roller specification	SR	See P.195

* When the lead is 20, it cannot be selected.

When selecting multiple options, please list them in alphabetical order. (e.g. B-CJB-NM)

③ Cable Length

Cable Type	Cable Code	RCP6	RCP6S
Standard	P (1m)	○	○
	S (3m)	○	○
	M (5m)	○	○
Specified Length	X06 (6m) ~X10 (10m)	○	○
	X11 (11m) ~X15 (15m)	○	○
	X16 (16m) ~X20 (20m)	○	○
	R01 (1m) ~R03 (3m)	○	○
Robot Cable	R04 (4m) ~R05 (5m)	○	○
	R06 (6m) ~R10 (10m)	○	○
	R11 (11m) ~R15 (15m)	○	○
	R16 (16m) ~R20 (20m)	○	○

* Please refer to P.267 and 283 for more information regarding the maintenance cables.

Actuator Specifications

Item	Description
Drive system	Ball screw φ16mm, rolled C10
Positioning repeatability (*1)	±0.01mm [±0.005mm]
Lost motion	0.1mm or less
Base	Material: Aluminum with white alumite treatment
Static allowable moment	Ma: 642N·m, Mb: 642N·m, Mc: 1,610N·m
Dynamic allowable moment (*2)	Ma: 161N·m, Mb: 161N·m, Mc: 404N·m
Ambient operating temp. & humidity	0~40°C, 85% RH or less (Non-condensing)

* Reference for overhang load length: Ma: 650mm or less, Mb, Mc: 650mm or less

(*1) Values in [] are for high-precision (for lead 5/10) specification.

(*2) Assumes a standard rated life of 5,000km. The service life will vary depending on operation and installation conditions.

Please refer to our website for more information regarding the directions of the allowable moment and overhang load length.

CAD drawings can be downloaded from our website.
www.intelligentactuator.com



*1 When the slider is returning to its home position, please be careful of interference from surrounding objects, as it will travel until it reaches the M.E.
M.E: Mechanical end
S.E: Stroke end

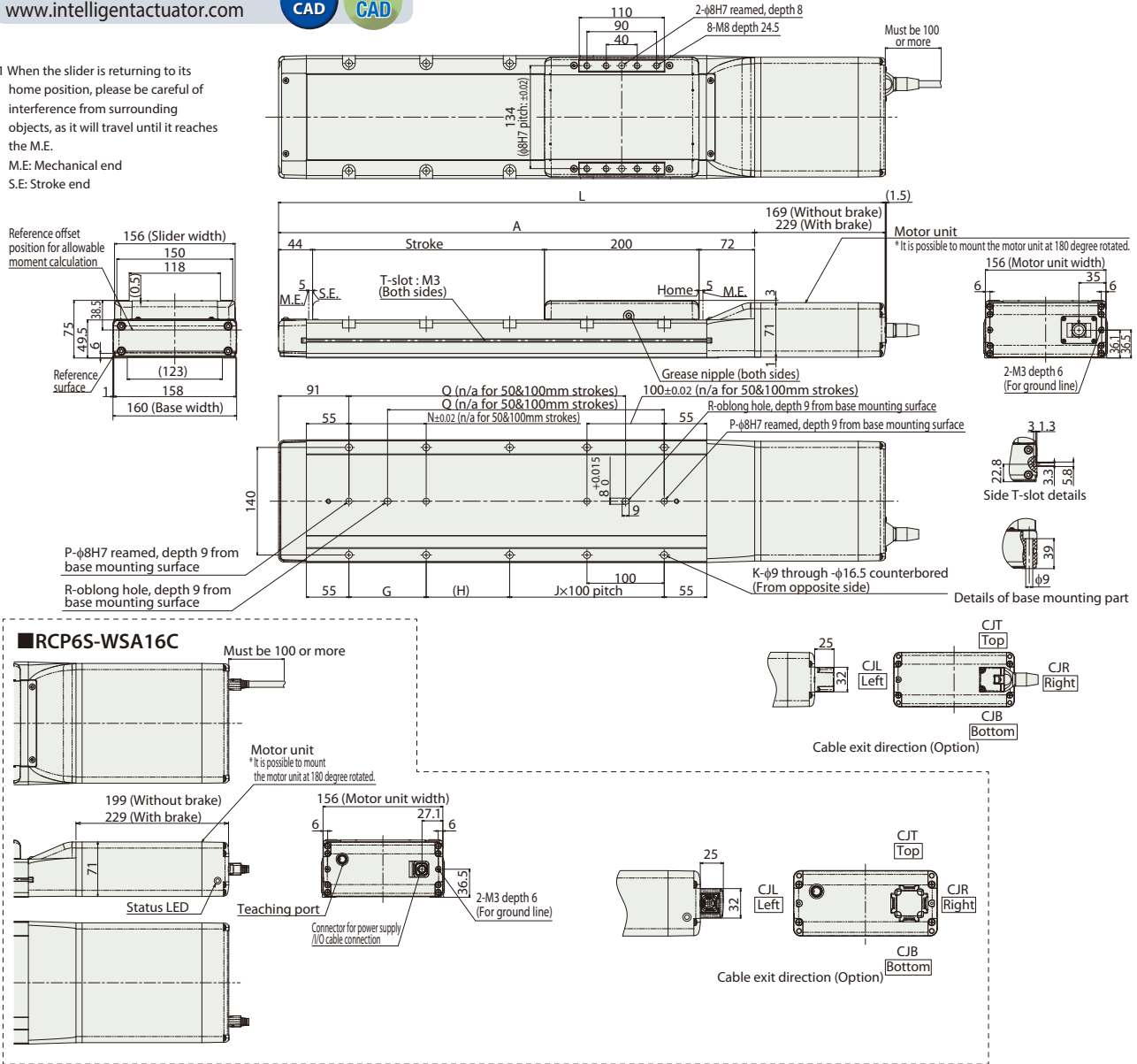

Dimensions and Mass by Stroke

Stroke	Stroke																							
	50	100	150	200	250	300	350	400	450	500	550	600	650	700	750	800	850	900	950	1,000	1,050	1,100		
L	RCP6	w/o brake	535	585	635	685	735	785	835	885	935	985	1,035	1,085	1,135	1,185	1,235	1,285	1,335	1,385	1,435	1,485	1,535	1,585
		w/ brake	595	645	695	745	795	845	895	945	995	1,045	1,095	1,145	1,195	1,245	1,295	1,345	1,395	1,445	1,495	1,545	1,595	1,645
	RCP6S	w/o brake	565	615	665	715	765	815	865	915	965	1,015	1,065	1,115	1,165	1,215	1,265	1,315	1,365	1,415	1,465	1,515	1,565	1,615
		w/ brake	595	645	695	745	795	845	895	945	995	1,045	1,095	1,145	1,195	1,245	1,295	1,345	1,395	1,445	1,495	1,545	1,595	1,645
	A	366	416	466	516	566	616	666	716	766	816	866	916	966	1,016	1,066	1,116	1,166	1,216	1,266	1,316	1,366	1,416	
	G	-	-	100	100	100	100	100	100	100	100	100	100	100	100	100	100	100	100	100	100	100	100	100
H	158	208	58	108	58	108	58	108	58	108	58	108	58	108	58	108	58	108	58	108	58	108	108	
J	0	0	1	1	2	2	3	3	4	4	5	5	6	6	7	7	8	8	9	9	10	10		
K	4	4	8	8	10	10	12	12	14	14	16	16	18	18	20	20	22	22	24	24	26	26		
N	-	-	100	100	100	100	100	100	100	100	100	100	100	100	100	100	100	100	100	100	100	100	100	
P	1	1	2	2	2	2	2	2	2	2	2	2	2	2	2	2	2	2	2	2	2	2	2	
Q	-	-	208	258	308	358	408	458	508	558	608	658	708	758	808	858	908	958	1008	1058	1108	1158		
R	0	0	1	1	1	1	1	1	1	1	1	1	1	1	1	1	1	1	1	1	1	1	1	
Mass (kg)	RCP6	w/o brake	9.0	9.6	10.2	10.8	11.4	12.0	12.6	13.2	13.8	14.4	15.0	15.7	16.2	16.9	17.4	18.1	18.7	19.3	19.9	20.5	21.1	21.7
		w/ brake	9.5	10.1	10.7	11.3	11.9	12.5	13.1	13.7	14.3	14.9	15.5	16.1	16.7	17.3	17.9	18.5	19.1	19.7	20.3	21.0	21.5	22.2
	RCP6S	w/o brake	9.2	9.8	10.4	11.0	11.6	12.2	12.8	13.4	14.0	14.6	15.2	15.8	16.4	17.0	17.6	18.2	18.8	19.4	20.0	20.6	21.2	21.8
		w/ brake	9.5	10.2	10.7	11.4	11.9	12.6	13.2	13.8	14.4	15.0	15.6	16.2	16.8	17.4	18.0	18.6	19.2	19.8	20.4	21.0	21.6	22.2

Applicable Controllers

The RCP6 series actuators can be operated by the controllers indicated below. Please select the type depending on your intended use. * Please refer to P.271 for more information about the built-in controller of RCP6S series.

Name	External view	Max. number of controlled axes	Input power	Control method				Maximum number of positioning points	Reference page
				Positioner	Pulse train	Program	Network *Option		
PCON-CFB/CGFB		1	DC24V	*Option	*Option	-	DeviceNet CompoNet EtherNet/IP CC-Link MECHATROLINK EtherCAT PROFINET	512 (768 for network spec.)	Please see P.255

RCP6(S)-WSA10R



Model Specification Items

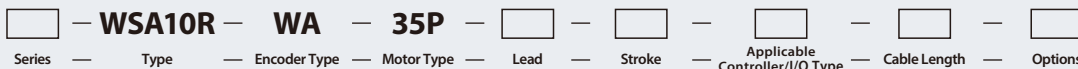

* RCP6 does not include a controller. RCP6S includes a built-in controller.
* Please refer to P.15 for more information about the model specification items.

* Body width does not include the width of the side-mounted motor.
Please refer to the options table below.
* Please make sure to specify either ML or MR when ordering the side-mounted motor type.

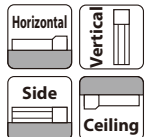

*Some limitations may apply to horizontal/side/ceiling mountings depending on the model. See page 204. Please contact IAI for more information.

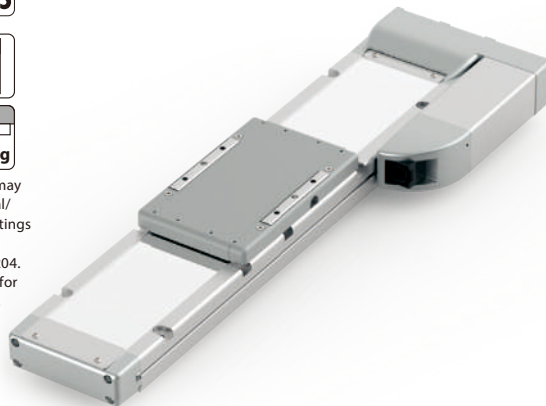

The figure above is the motor side-mounted to the left (ML).

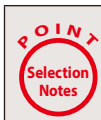

- The maximum acceleration/deceleration is 1G for horizontal, and 0.5G for vertical use.
- The actuator specification displays the payload's maximum value, but it will vary depending on the acceleration and speed. Please refer to the "Selection Guidelines" (Tables of Payload by Speed/Acceleration) on P.213 for more details.
- Please refer to P205 for performing push-motion operation.

Correlation Diagrams of Speed and Payload

(1) High-output enabled with PCON/MCON/MSEL connected.

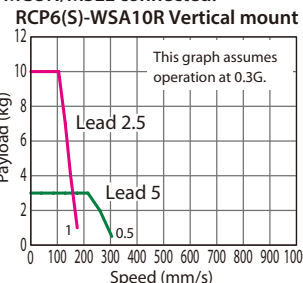
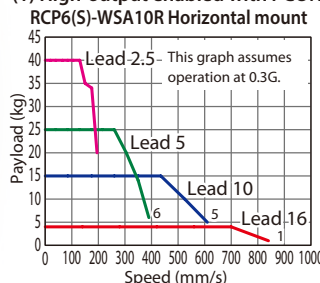

(2) High-output disabled with PCON/MCON connected.

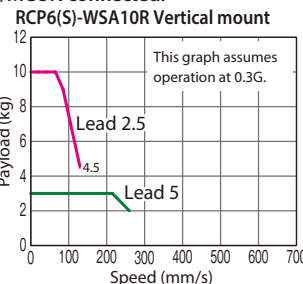
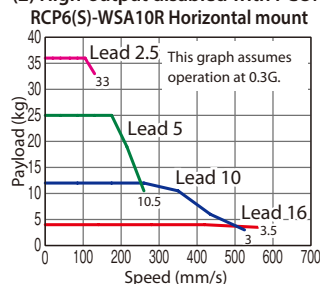

Actuator Specifications

Lead and Payload

* Push force only available during push mode w / limited speed.

Model Number	Lead (mm)	Connected Controller	Max. Payload		Max Push Force (N)*
			Horizontal (kg)	Vertical (kg)	
RCP6(S)-WSA10R-WA-35P-16-①-②-③-④	16	High-output Enabled	4	—	48
		High-output Disabled	4	—	48
RCP6(S)-WSA10R-WA-35P-10-①-②-③-④	10	High-output Enabled	15	—	77
		High-output Disabled	12	—	77
RCP6(S)-WSA10R-WA-35P-5-①-②-③-④	5	High-output Enabled	28	3	155
		High-output Disabled	25	3	155
RCP6(S)-WSA10R-WA-35P-2.5-①-②-③-④	2.5	High-output Enabled	40	10	310
		High-output Disabled	36	10	310

Legend: ① Stroke ② Applicable controller/I/O type ③ Cable length ④ Options

Stroke and Max. Speed

(Unit: mm/s)

Lead (mm)	Connected Controller	Max. Speed			
		50~300 (Every 50mm)	350 (mm)	400 (mm)	450 (mm)
16	High-output Enabled	840	775	660	
	High-output Disabled	560			
10	High-output Enabled	610	590	490	415
	High-output Disabled	525			
5	High-output Enabled	390<305>	355<305>	290	245
	High-output Disabled	260			205
2.5	High-output Enabled	195<175>	175	145	120
	High-output Disabled	130			100

Values in brackets < > are for vertical use.

① Stroke

Stroke (mm)	RCP6	RCP6S	Stroke (mm)	RCP6	RCP6S
50	○	○	300	○	○
100	○	○	350	○	○
150	○	○	400	○	○
200	○	○	450	○	○
250	○	○	500	○	○

③ Cable Length

Cable Type	Cable Code	RCP6			RCP6S
		P3	P5	SE	
Standard	P (1m)	○	○	○	○
	S (3m)	○	○	○	○
	M (5m)	○	○	○	○
Specified Length	X06 (6m) ~X10 (10m)	○	○	○	○
	X11 (11m) ~X15 (15m)	○	○	○	○
	X16 (16m) ~X20 (20m)	○	○	○	○
	R01 (1m) ~R03 (3m)	○	○	○	○
Robot Cable	R04 (4m) ~R05 (5m)	○	○	○	○
	R06 (6m) ~R10 (10m)	○	○	○	○
	R11 (11m) ~R15 (15m)	○	○	○	○
	R16 (16m) ~R20 (20m)	○	○	○	○

* Please refer to P.267 and 283 for more information regarding the maintenance cables.

④ Options

Name	Option Code	Reference Page
Brake	B	See P.189
Cable exit direction (Outside)	CJO	See P.189
Motor side-mounted to the left	ML	See P.193
Motor side-mounted to the right	MR	See P.193
Non-motor end specification	NM	See P.194
Slider roller specification	SR	See P.195

When selecting multiple options, please list them in alphabetical order. (e.g. B-CJ-BM)

Actuator Specifications

Item	Description
Drive system	Ball screw φ8mm, rolled C10
Positioning repeatability	±0.01mm
Lost motion	0.1mm or less
Base	Material: Aluminum with white alumite treatment
Static allowable moment	Ma: 271N·m, Mb: 271N·m, Mc: 553N·m
Dynamic allowable moment (*1)	Ma: 65.4N·m, Mb: 65.4N·m, Mc: 134N·m
Ambient operating temp. & humidity	0~40°C, 85% RH or less (Non-condensing)

* Reference for overhang load length: Ma: 500mm or less, Mb, Mc: 500mm or less

(*1) Assumes a standard rated life of 5,000km. The service life will vary depending on operation and installation conditions. Please refer to our website for more information regarding the directions of the allowable moment and overhang load length.



*1 When the slider is returning to its home position, please be careful of interference from surrounding objects, as it will travel until it reaches the M.E.
M.E: Mechanical end S.E: Stroke end

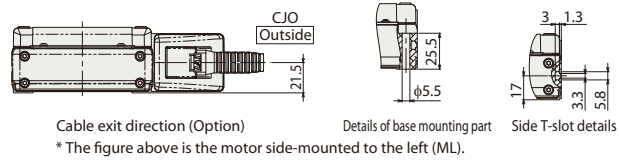
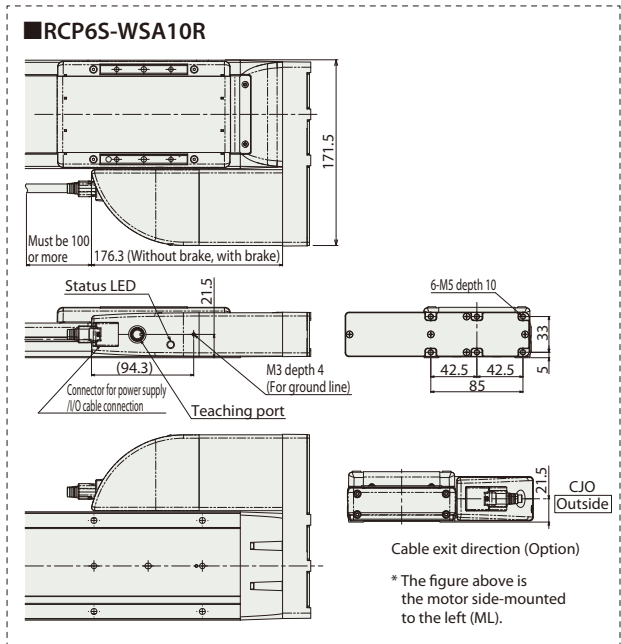
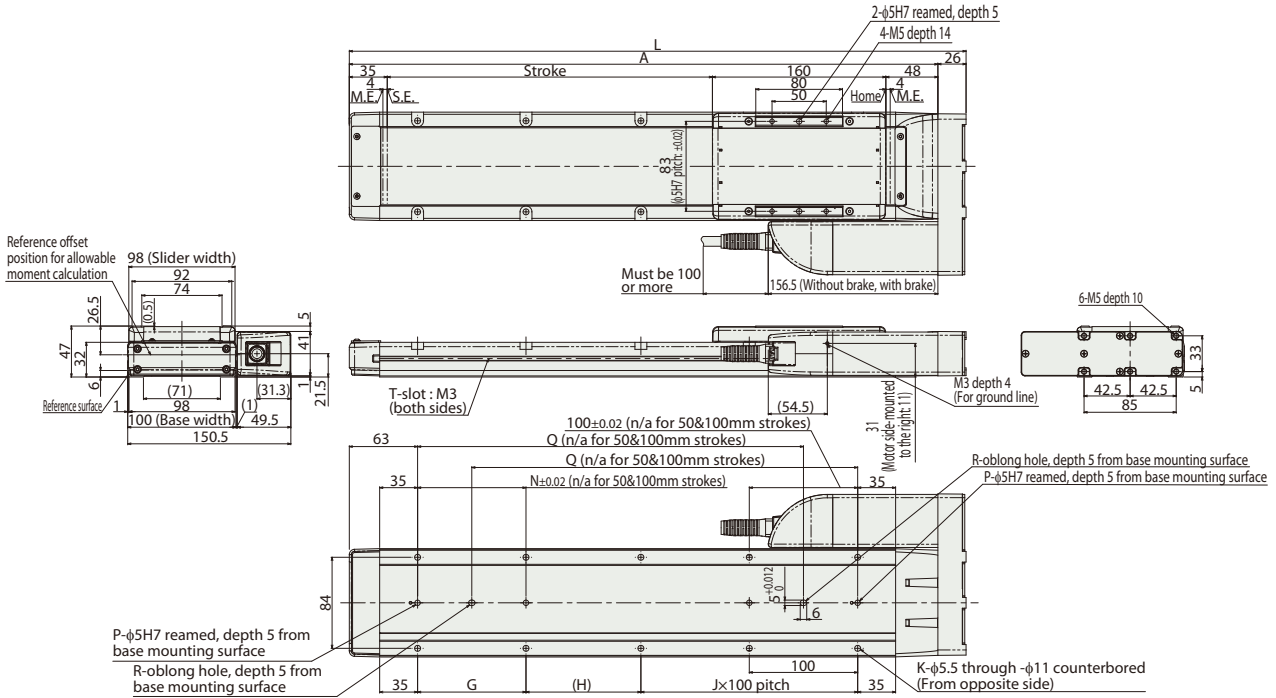

■ Dimensions and Mass by Stroke

Stroke	50	100	150	200	250	300	350	400	450	500	
L	319	369	419	469	519	569	619	669	719	769	
A	293	343	393	443	493	543	593	643	693	743	
G	-	-	100	100	100	100	100	100	100	100	
H	156	206	56	106	56	106	56	106	56	106	
J	0	0	1	1	2	2	3	3	4	4	
K	4	4	8	8	10	10	12	12	14	14	
N	-	-	100	100	100	100	100	100	100	100	
P	1	1	2	2	2	2	2	2	2	2	
Q	-	-	206	256	306	356	406	456	506	556	
R	0	0	1	1	1	1	1	1	1	1	
Mass (kg)	RCP6	w/o brake	2.9	3.2	3.4	3.6	3.9	4.1	4.4	4.6	4.8
		w/brake	3.0	3.2	3.5	3.7	3.9	4.2	4.4	4.7	4.9
		w/o brake	3.0	3.3	3.5	3.8	4.0	4.3	4.5	4.7	5.0
		w/brake	3.1	3.4	3.6	3.8	4.1	4.3	4.6	4.8	5.0
RCP6S	w/o brake	3.1	3.4	3.6	3.8	4.1	4.3	4.6	4.8	5.0	
	w/brake	3.1	3.4	3.6	3.8	4.1	4.3	4.6	4.8	5.0	
	w/o brake	3.1	3.4	3.6	3.8	4.1	4.3	4.6	4.8	5.0	
	w/brake	3.1	3.4	3.6	3.8	4.1	4.3	4.6	4.8	5.0	

② Applicable Controllers

The RCP6 series actuators can be operated by the controllers indicated below. Please select the type depending on your intended use. * Please refer to P.271 for more information about the built-in controller of RCP6S series.

Name	External view	Max. number of controlled axes	Input power	Control method				Maximum number of positioning points	Reference page
				Positioner	Pulse train	Program	Network * Option		
PCON-CYB/PLB/POB		1	DC24V	●	●	-	Network cannot be selected	64	Please contact IAI for more information.
PCON-CB/CGB		1		* Option	* Option	-	DeviceNet, MECHATROLINK, CC-Link, EtherCAT, EtherNet/IP, CANopen	512 (768 for network spec.)	Please see P.255
MCON-C/CG		8		This model is network-compatible only.				256	Please contact IAI for more information.
MCON-LC/LCG		6		-	-	●	CompoNet, SSCNET III/H	256	Please contact IAI for more information.
MSEL-PC/PG		4	Single-phase 100 ~ 230 VAC	-	-	●	Note: The type of compatible networks will vary depending on the controller. Please refer to reference page for more information.	30,000	Please contact IAI for more information.
RCM-P6PC		1	Usable within the RCP6S Gateway system.				768	Please see P.279	

* For the MCON controller, high-output enabled operation is only available if "high-output setting" is selected as an option. The maximum connectable axes with high-output enabled are C: 4 and LC: 3.

Foreword
Slider Type
Wide Slider Type
Rod Type
Radial Cylinder
Wide Radial Cylinder
Table Type
Cleanroom Slider
Cleanroom Wide Slider
Dust/Splash-Proof Rod
Dust/Splash-Proof Radial Cylinder
Dust/Splash-Proof Wide Radial Cylinder
Options
Reference Data
Controller

RCP6(S)-WSA12R



Model Specification Items

Series	Type	Encoder Type	Motor Type	Lead	Stroke	Applicable Controller/I/O Type	Cable Length	Options
RCP6: Separate Controller RCP6S: Built-in Controller	WSA12R	WA	42P	20: 20mm 12: 12mm 6: 6mm 3: 3mm	50: 50mm 800: 800mm (50mm increments)	[RCP6] P3: PCON MCON MSEL P5: RCM-P6PC [RCP6S] SE: SIO Type	N: None P: 1m S: 3m M: 5m X□□: Specified Length R□□: Robot Cable	Please refer to the options table below. *Please make sure to specify either ML or MR when ordering the side-mounted motor type.

* RCP6 does not include a controller. RCP6S includes a built-in controller.
* Please refer to P.15 for more information about the model specification items.

* Body width does not include the width of the side-mounted motor.

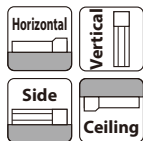

*Some limitations may apply to horizontal/side/ceiling mountings depending on the model. See page 204. Please contact IAI for more information.

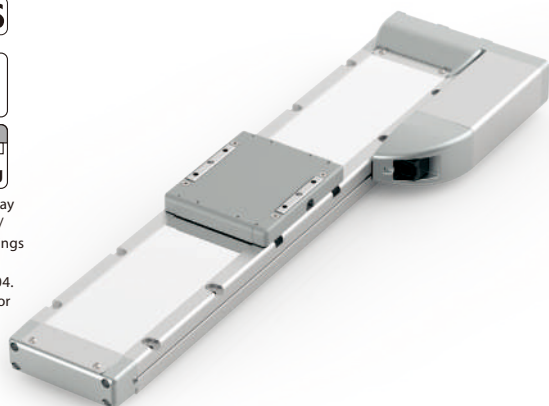

The figure above is the motor side-mounted to the left (ML).

	(1) The maximum acceleration/deceleration is 1G for horizontal, and 0.5G for vertical use.
	(2) The actuator specification displays the payload's maximum value, but it will vary depending on the acceleration and speed. Please refer to the "Selection Guidelines" (Tables of Payload by Speed/Acceleration) on P.213 for more details.
	(3) Please refer to P.205 for performing push-motion operation.
	(4) Depending on the ambient operational temperature, duty control is necessary for the RCP6S (built-in controller type) with lead 3/6. Please refer to P.247 for more information.

Correlation Diagrams of Speed and Payload

(1) High-output enabled with PCON/MCON/MSEL connected.

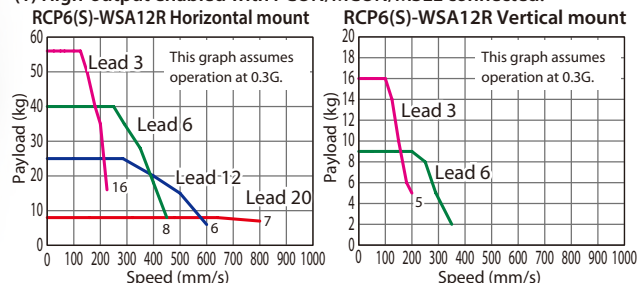

(2) High-output disabled with PCON/MCON connected.

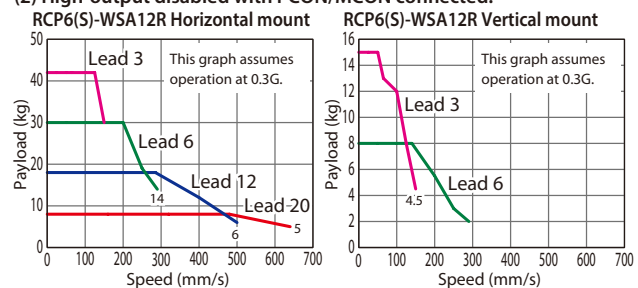

Actuator Specifications

Lead and Payload

* Push force only available during push mode w / limited speed.

Model Number	Lead (mm)	Connected Controller	Max. Payload		Max. Push Force (N)*
			Horizontal (kg)	Vertical (kg)	
RCP6(S)-WSA12R-WA-42P-20-①-②-③-④	20	High-output Enabled	12	-	56
		High-output Disabled	8	-	
RCP6(S)-WSA12R-WA-42P-12-①-②-③-④	12	High-output Enabled	25	-	93
		High-output Disabled	18	-	
RCP6(S)-WSA12R-WA-42P-6-①-②-③-④	6	High-output Enabled	40	9	185
		High-output Disabled	30	8	
RCP6(S)-WSA12R-WA-42P-3-①-②-③-④	3	High-output Enabled	60	16	370
		High-output Disabled	42	15	

Legend: ① Stroke ② Applicable controller/I/O type ③ Cable length ④ Options

Stroke and Max. Speed

(Unit: mm/s)

Lead (mm)	Connected Controller	50~350 (Every 50mm)	400 (mm)	450 (mm)	500 (mm)	550 (mm)	600 (mm)	650 (mm)	700 (mm)	750 (mm)	800 (mm)
20	High-output Enabled	800			740	650	580	520			
	High-output Disabled	640				580	520				
12	High-output Enabled	600		535	465	405	355	315	285		
	High-output Disabled	500			465	405	355	315	285		
6	High-output Enabled	450<400>	435<400>	365	310	265	230	200	175	155	140
	High-output Disabled	290			265	230	200	175	155	140	
3	High-output Enabled	225	215	180	150	130	115	100	85	75	70
	High-output Disabled	150			130	115	100	85	75	70	

Values in brackets < > are for vertical use.

① Stroke

Stroke (mm)	RCP6	RCP6S	Stroke (mm)	RCP6	RCP6S
50	○	○	450	○	○
100	○	○	500	○	○
150	○	○	550	○	○
200	○	○	600	○	○
250	○	○	650	○	○
300	○	○	700	○	○
350	○	○	750	○	○
400	○	○	800	○	○

③ Cable Length

Cable Type	Cable Code	RCP6			RCP6S
		P3	P5	SE	
Standard	P (1m)	○	○	○	
	S (3m)	○	○	○	
	M (5m)	○	○	○	
Specified Length	X06 (6m) ~X10 (10m)	○	○	○	
	X11 (11m) ~X15 (15m)	○	○	○	
	X16 (16m) ~X20 (20m)	○	○	○	
		○	○	○	
Robot Cable	R01 (1m) ~R03 (3m)	○	○	○	
	R04 (4m) ~R05 (5m)	○	○	○	
	R06 (6m) ~R10 (10m)	○	○	○	
	R11 (11m) ~R15 (15m)	○	○	○	
	R16 (16m) ~R20 (20m)	○	○	○	
		○	○	○	

* Please refer to P.267 and 283 for more information regarding the maintenance cables.

④ Options

Name	Option Code	Reference Page
Brake	B	See P.189
Cable exit direction (Outside)	CJO	See P.189
Motor side-mounted to the left	ML	See P.193
Motor side-mounted to the right	MR	See P.193
Non-motor end specification	NM	See P.194
Slider roller specification	SR	See P.195

When selecting multiple options, please list them in alphabetical order. (e.g. B-CJB-NM)

Actuator Specifications

Item	Description
Drive system	Ball screw φ10mm, rolled C10
Positioning repeatability	±0.01mm
Lost motion	0.1mm or less
Base	Material: Aluminum with white alumite treatment
Static allowable moment	Ma: 311N·m, Mb: 311N·m, Mc: 827N·m
Dynamic allowable moment (*1)	Ma: 87.5N·m, Mb: 87.5N·m, Mc: 233N·m
Ambient operating temp. & humidity	0~40°C, 85% RH or less (Non-condensing)

* Reference for overhang load length: Ma: 450mm or less, Mb, Mc: 450mm or less
(*1) Assumes a standard rated life of 5,000km. The service life will vary depending on operation and installation conditions. Please refer to our website for more information regarding the directions of the allowable moment and overhang load length.



*1 When the slider is returning to its home position, please be careful of interference from surrounding objects, as it will travel until it reaches the M.E.
M.E: Mechanical end S.E: Stroke end

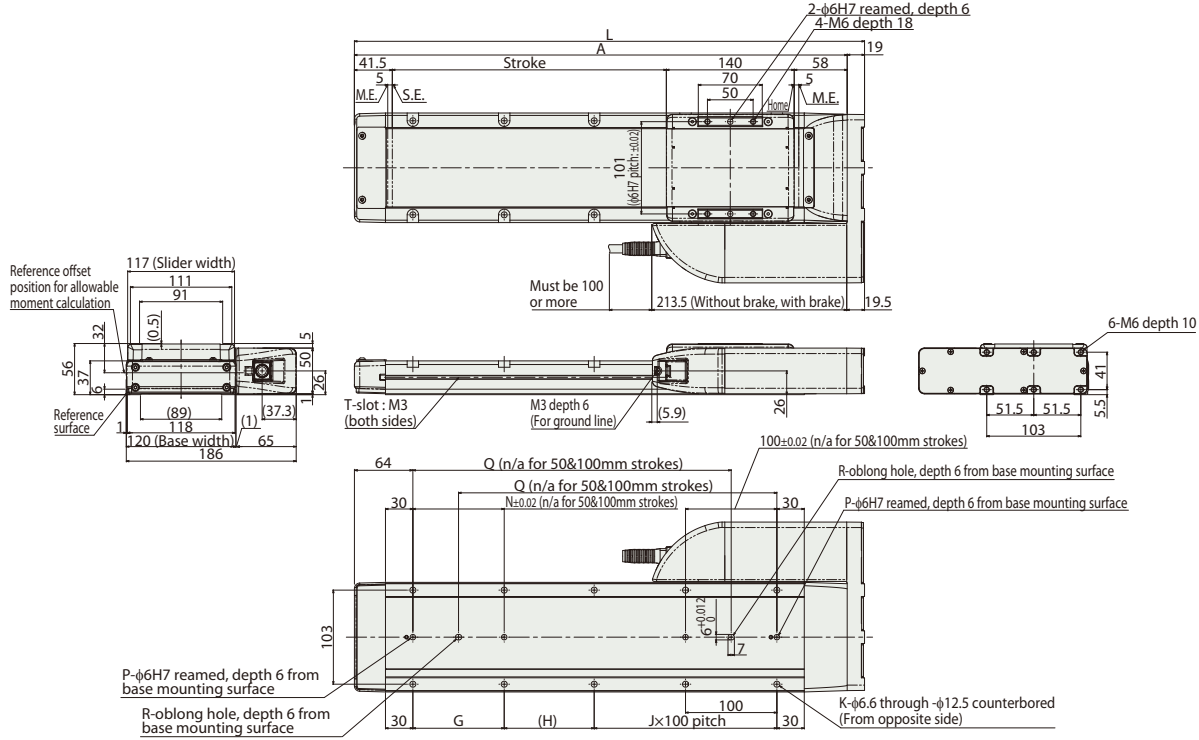

■ RCP6S-WSA12R

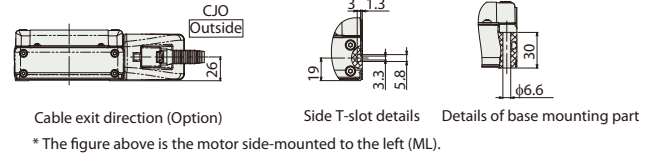
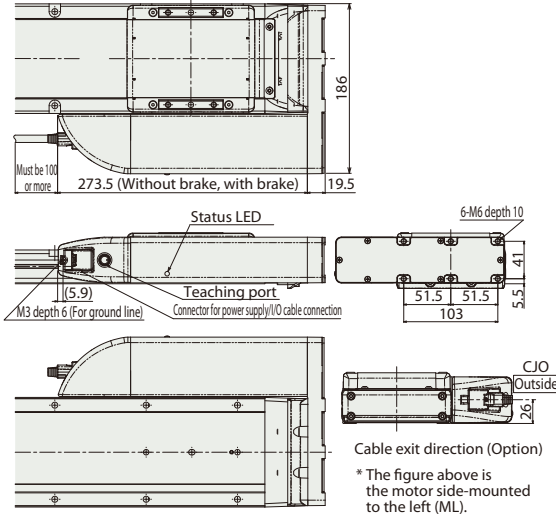

■ Dimensions and Mass by Stroke

Stroke	50	100	150	200	250	300	350	400	450	500	550	600	650	700	750	800
L	308.5	358.5	408.5	458.5	508.5	558.5	608.5	658.5	708.5	758.5	808.5	858.5	908.5	958.5	1,008.5	1,058.5
A	289.5	339.5	389.5	439.5	489.5	539.5	589.5	639.5	689.5	739.5	789.5	839.5	889.5	939.5	989.5	1,039.5
G	-	-	100	100	100	100	100	100	100	100	100	100	100	100	100	100
H	148.5	198.5	248.5	298.5	348.5	398.5	448.5	498.5	548.5	598.5	648.5	698.5	748.5	798.5	848.5	898.5
J	0	0	1	1	2	2	3	3	4	4	5	5	6	6	7	7
K	4	4	8	8	10	10	12	12	14	14	16	16	18	18	20	20
N	-	-	100	100	100	100	100	100	100	100	100	100	100	100	100	100
P	1	1	2	2	2	2	2	2	2	2	2	2	2	2	2	2
Q	-	-	198.5	248.5	298.5	348.5	398.5	448.5	498.5	548.5	598.5	648.5	698.5	748.5	798.5	848.5
R	0	0	1	1	1	1	1	1	1	1	1	1	1	1	1	1
Mass (kg)	RCP6	4.1	4.4	4.7	5.1	5.4	5.7	6.1	6.4	6.7	7.1	7.4	7.7	8.1	8.4	8.7
	w/brake	4.1	4.5	4.8	5.1	5.5	5.8	6.1	6.5	6.8	7.1	7.5	7.8	8.1	8.5	8.8
RCP6S	w/o brake	4.2	4.5	4.9	5.2	5.5	5.9	6.2	6.5	6.9	7.2	7.5	7.9	8.2	8.5	8.9
	w/brake	4.3	4.6	4.9	5.3	5.6	5.9	6.3	6.6	6.9	7.3	7.6	7.9	8.3	8.6	8.9

② Applicable Controllers

The RCP6 series actuators can be operated by the controllers indicated below. Please select the type depending on your intended use. * Please refer to P.271 for more information about the built-in controller of RCP6S series.

Name	External view	Max. number of controlled axes	Input power	Control method				Maximum number of positioning points	Reference page
				Positioner	Pulse train	Program	Network * Option		
PCON-CYB/PLB/POB		1	DC24V	●	●	-	Network cannot be selected	64	Please contact IAI for more information.
PCON-CB/CGB		1		* Option	* Option	-	DeviceNet, MECHATROLINK, CC-Link, EtherCAT, EtherNet/IP, CompoNet	512 (768 for network spec.)	Please see P.255
MCON-C/CG		8		This model is network-compatible only.				256	Please contact IAI for more information.
MCON-LC/LCG		6		-	-	●	SSCNET III/H	256	Please contact IAI for more information.
MSEL-PC/PG		4	Single-phase 100 ~ 230 VAC	-	-	●	Note: The type of compatible networks will vary depending on the controller. Please refer to reference page for more information.	30,000	Please contact IAI for more information.
RCM-P6PC		1	Usable within the RCP6S Gateway system.				768	Please see P.279	

* For the MCON controller, high-output enabled operation is only available if "high-output setting" is selected as an option. The maximum connectable axes with high-output enabled are C: 4 and LC: 3.

Foreword
Slider Type
Wide Slider Type
Rod Type
Radial Cylinder
Wide Radial Cylinder
Table Type
Cleanroom Slider
Cleanroom Wide Slider
Dust/Splash-Proof Rod
Dust/Splash-Proof Radial Cylinder
Dust/Splash-Proof Wide Radial Cylinder
Options
Reference Data
Controller

RCP6(S)-WSA14R



Model Specification Items

Series	Type	Encoder Type	Motor Type	Lead	Stroke	Applicable Controller/I/O Type	Cable Length	Options
RCP6: Separate Controller RCP6S: Built-in Controller	WSA14R	WA	56P	24: 24mm 16: 16mm 8: 8mm 4: 4mm	50: 50mm 800: 800mm (50mm increments)	[RCP6] P3: PCON MCON MSEL P5: RCM-P6PC [RCP6S] SE: SIO Type	N: None P: 1m S: 3m M: 5m □□□: Specified Length R□□: Robot Cable	Please refer to the options table below. *Please make sure to specify either ML or MR when ordering the side-mounted motor type.

* RCP6 does not include a controller. RCP6S includes a built-in controller.
* Please refer to P.15 for more information about the model specification items.

* Body width does not include the width of the side-mounted motor.

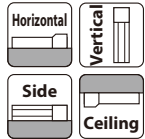

*Some limitations may apply to horizontal/side/ceiling mountings depending on the model. See page 204. Please contact IAI for more information.

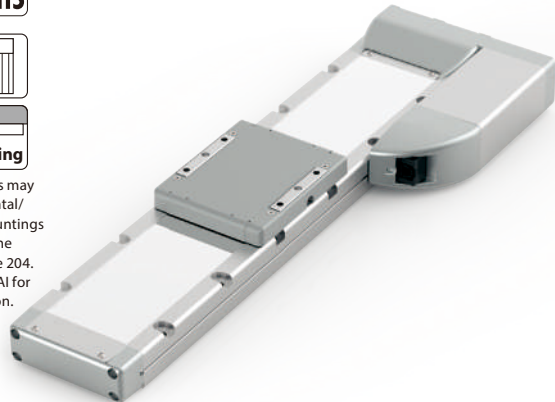

The figure above is the motor side-mounted to the left (ML).

POINT Selection Notes

- (1) The maximum acceleration/deceleration is 1G for horizontal, and 0.5G for vertical use.
- (2) The actuator specification displays the payload's maximum value, but it will vary depending on the acceleration and speed. Please refer to the "Selection Guidelines" (Tables of Payload by Speed/Acceleration) on P.213 for more details.
- (3) Please refer to P.205 for performing push-motion operation.
- (4) Depending on the ambient operational temperature, duty control is necessary for the RCP6S (built-in controller type) with lead 4/8/16. Please refer to P.247 for more information.

Correlation Diagrams of Speed and Payload

(1) High-output enabled with PCON/MCON/MSEL connected.

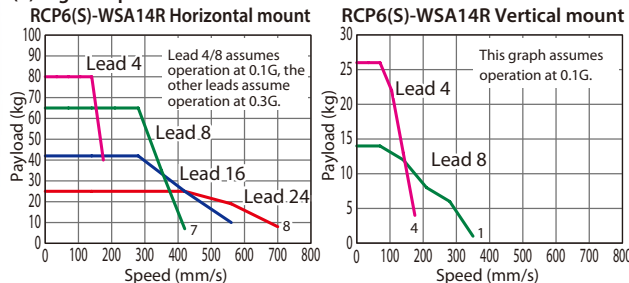

(2) High-output disabled with PCON/MCON connected.

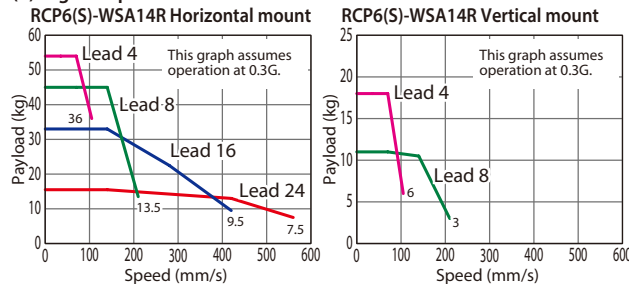

Actuator Specifications

Lead and Payload

* Push force only available during push mode w / limited speed.

Model Number	Lead (mm)	Connected Controller	Max. Payload		Max. Payload Force (N)*
			Horizontal (kg)	Vertical (kg)	
RCP6(S)-WSA14R-WA-56P-24-①-②-③-④	24	High-output Enabled	25	-	112
		High-output Disabled	15.5	-	
RCP6(S)-WSA14R-WA-56P-16-①-②-③-④	16	High-output Enabled	50	-	168
		High-output Disabled	33	-	
RCP6(S)-WSA14R-WA-56P-8-①-②-③-④	8	High-output Enabled	65	14	336
		High-output Disabled	45	11	
RCP6(S)-WSA14R-WA-56P-4-①-②-③-④	4	High-output Enabled	80	26	673
		High-output Disabled	54	18	

Legend: ① Stroke ② Applicable controller/I/O type ③ Cable length ④ Options

Stroke and Max. Speed

(Unit: mm/s)

Lead (mm)	Connected Controller	Max. Speed						
		50~500 (Every 50mm)	550 (mm)	600 (mm)	650 (mm)	700 (mm)	750 (mm)	800 (mm)
24	High-output Enabled	700					665	
	High-output Disabled	560						
16	High-output Enabled	560			550	490	440	
	High-output Disabled	420						
8	High-output Enabled	420<350>	400<350>	350	305	270	240	215
	High-output Disabled	210						
4	High-output Enabled	175	170	150	135	120	105	
	High-output Disabled	105						

Values in brackets < > are for vertical use.

① Stroke

Stroke (mm)	RCP6	RCP6S	Stroke (mm)	RCP6	RCP6S
50	○	○	450	○	○
100	○	○	500	○	○
150	○	○	550	○	○
200	○	○	600	○	○
250	○	○	650	○	○
300	○	○	700	○	○
350	○	○	750	○	○
400	○	○	800	○	○

③ Cable Length

Cable Type	Cable Code	RCP6			RCP6S
		P3	P5	SE	
Standard	P (1m)	○	○	○	○
	S (3m)	○	○	○	○
	M (5m)	○	○	○	○
Specified Length	X06 (6m) ~X10 (10m)	○	○	○	○
	X11 (11m) ~X15 (15m)	○	○	○	○
	X16 (16m) ~X20 (20m)	○	○	○	○
	R01 (1m) ~R03 (3m)	○	○	○	○
Robot Cable	R04 (4m) ~R05 (5m)	○	○	○	○
	R06 (6m) ~R10 (10m)	○	○	○	○
	R11 (11m) ~R15 (15m)	○	○	○	○
	R16 (16m) ~R20 (20m)	○	○	○	○
		○	○	○	○
		○	○	○	○

* Please refer to P.267 and 283 for more information regarding the maintenance cables.

④ Options

Name	Option Code	Reference Page
Brake	B	See P.189
Cable exit direction (Outside)	CJO	See P.189
Motor side-mounted to the left	ML	See P.193
Motor side-mounted to the right	MR	See P.193
Non-motor end specification	NM	See P.194
Slider roller specification	SR	See P.195

When selecting multiple options, please list them in alphabetical order. (e.g. B-CJB-NM)

Actuator Specifications

Item	Description
Drive system	Ball screw φ12mm, rolled C10
Positioning repeatability	±0.01mm
Lost motion	0.1mm or less
Base	Material: Aluminum with white alumite treatment
Static allowable moment	Ma: 462N-m, Mb: 462N-m, Mc: 1,170N-m
Dynamic allowable moment (*1)	Ma: 122N-m, Mb: 122N-m, Mc: 308N-m
Ambient operating temp. & humidity	0~40°C, 85% RH or less (Non-condensing)

* Reference for overhang load length: Ma: 550mm or less, Mb, Mc: 550mm or less

(*1) Assumes a standard rated life of 5,000km. The service life will vary depending on operation and installation conditions. Please refer to our website for more information regarding the directions of the allowable moment and overhang load length.

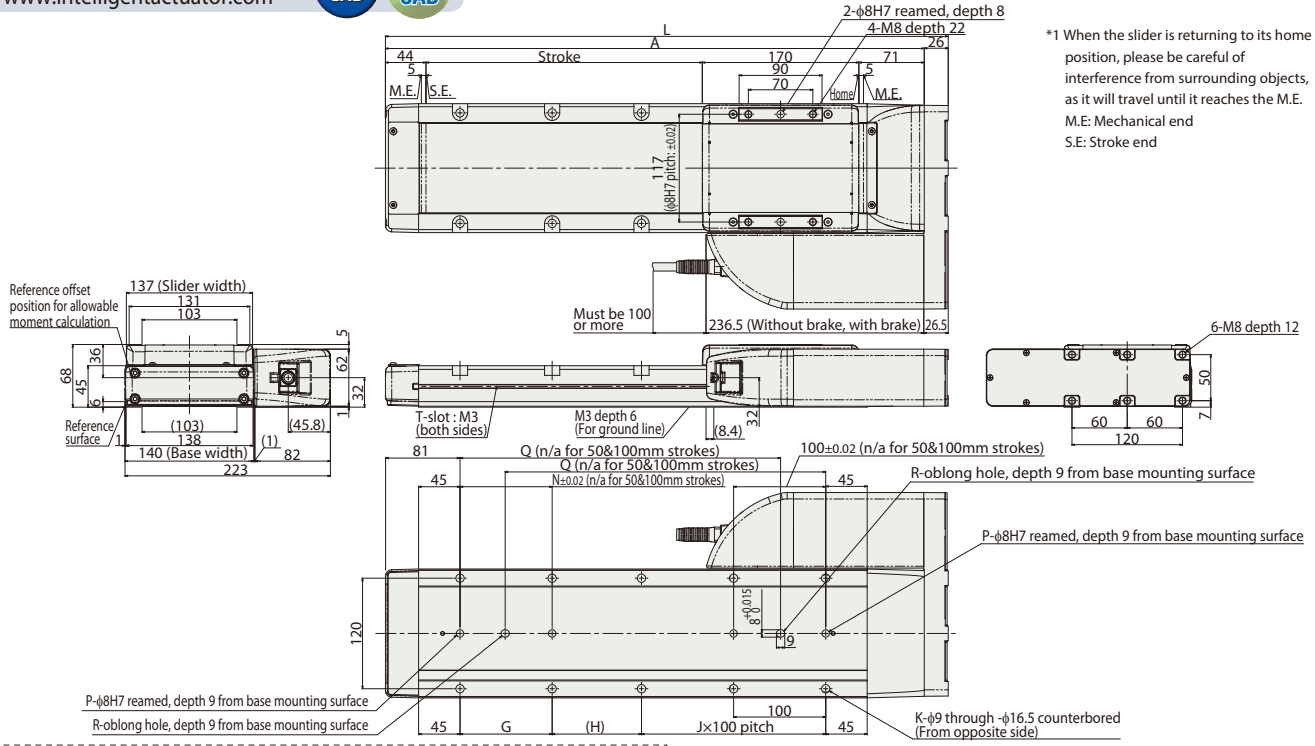

*1 When the slider is returning to its home position, please be careful of interference from surrounding objects, as it will travel until it reaches the M.E.
M.E: Mechanical end
S.E: Stroke end

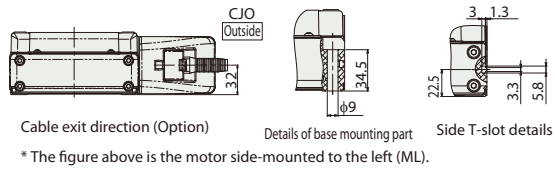
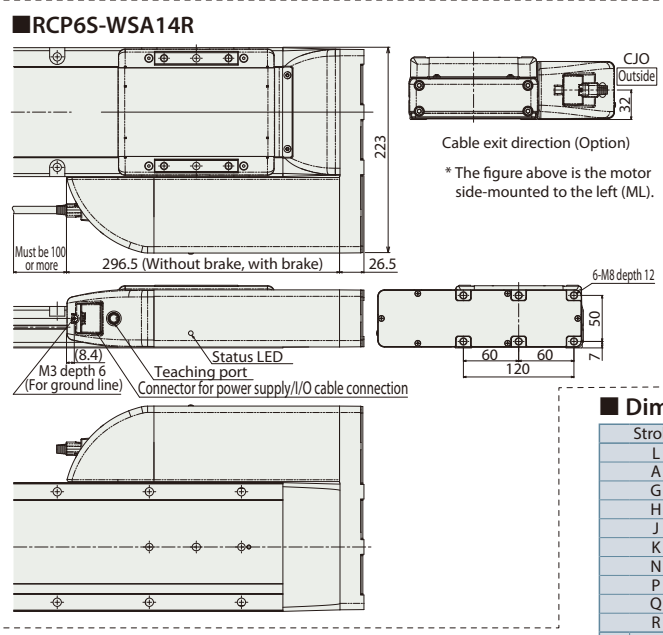

■ Dimensions and Mass by Stroke

Stroke	50	100	150	200	250	300	350	400	450	500	550	600	650	700	750	800	
L	361	411	461	511	561	611	661	711	761	811	861	911	961	1,011	1,061	1,111	
A	335	385	435	485	535	585	635	685	735	785	835	885	935	985	1,035	1,085	
G	-	-	100	100	100	100	100	100	100	100	100	100	100	100	100	100	
H	147	197	47	97	47	97	47	97	47	97	47	97	47	97	47	97	
J	0	0	1	1	2	2	3	3	4	4	5	5	6	6	7	7	
K	4	4	8	8	10	10	12	12	14	14	16	16	18	18	20	20	
N	-	-	100	100	100	100	100	100	100	100	100	100	100	100	100	100	
P	1	1	2	2	2	2	2	2	2	2	2	2	2	2	2	2	
Q	-	-	198	248	298	348	398	448	498	548	598	648	698	748	798	848	
R	0	0	1	1	1	1	1	1	1	1	1	1	1	1	1	1	
Mass (kg)	RCP6	7.3	7.8	8.2	8.7	9.2	9.6	10.1	10.6	11.1	11.5	12.0	12.5	13.0	13.4	13.9	14.4
	w/brake	7.4	7.9	8.3	8.8	9.3	9.8	10.2	10.7	11.2	11.7	12.1	12.6	13.1	13.6	14.0	14.5
RCP6S	w/brake	7.4	7.9	8.4	8.9	9.3	9.8	10.3	10.8	11.2	11.7	12.2	12.7	13.1	13.6	14.1	14.6
	w/brake	7.6	8.0	8.5	9.0	9.4	9.9	10.4	10.9	11.4	11.8	12.3	12.8	13.3	13.7	14.2	14.7

② Applicable Controllers

The RCP6 series actuators can be operated by the controllers indicated below. Please select the type depending on your intended use. * Please refer to P.271 for more information about the built-in controller of RCP6S series.

Name	External view	Max. number of controlled axes	Input power	Control method				Maximum number of positioning points	Reference page
				Positioner	Pulse train	Program	Network * Option		
PCON-CYB/PLB/POB		1	DC24V	●	●	-	Network cannot be selected	64	Please contact IAI for more information.
PCON-CB/CGB		1		* Option	* Option	-	DeviceNet MECHATROLINK CC-Link EtherCAT EtherNet/IP CANopen CompoNet	512	Please see P.255
MCON-C/CG		8		This model is network-compatible only.				256	
MCON-LC/LCG		6		-	-	●	Note: The type of compatible networks will vary depending on the controller. Please refer to reference page for more information.	256	Please contact IAI for more information.
MSEL-PC/PG		4	Single-phase 100 ~ 230 VAC	-	-	●		30,000	Please contact IAI for more information.
RCM-P6PC		1		Usable within the RCP6S Gateway system.				768	Please see P.279

* For the MCON controller, high-output enabled operation is only available if "high-output setting" is selected as an option. The maximum connectable axes with high-output enabled are C: 4 and LC: 3.

Foreword
Slider Type
Wide Slider Type
Rod Type
Radial Cylinder
Wide Radial Cylinder
Table Type
Cleanroom Slider
Cleanroom Wide Slider
Dust/Splash-Proof Rod
Dust/Splash-Proof Radial Cylinder
Dust/Splash-Proof Wide Radial Cylinder
Options
Reference Data
Controller

RCP6(S)-WSA16R



Model Specification Items

Series	Type	Encoder Type	Motor Type	Lead	Stroke	Applicable Controller/I/O Type	Cable Length	Options
RCP6: Separate Controller RCP6S: Built-in Controller	WSA16R	WA	56SP	20: 20mm 10: 10mm 5: 5mm	50: 50mm 1100: 1,100mm (50mm increments)	[RCP6] P4: PCON- CFB/CGFB [RCP6S] SE: SIO Type	N: None P: 1m S: 3m M: 5m X□□: Specified Length R□□: Robot Cable	Please refer to the options table below. *Please make sure to specify either ML or MR when ordering the side-mounted motor type.

* RCP6 does not include a controller. RCP6S includes a built-in controller.
* Please refer to P.15 for more information about the model specification items.

* Body width does not include the width of the side-mounted motor.

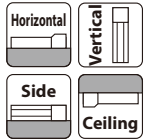

*Some limitations may apply to horizontal/side/ceiling mountings depending on the model. See page 204. Please contact IAI for more information.

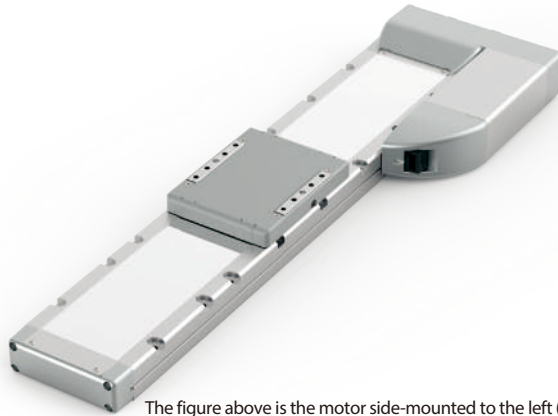

The figure above is the motor side-mounted to the left (ML).

- POINT Selection Notes**
- (1) The maximum acceleration/deceleration is 1G for horizontal, and 0.5G for vertical use.
 - (2) The actuator specification displays the payload's maximum value, but it will vary depending on the acceleration and speed. Please refer to the "Selection Guidelines" (Tables of Payload by Speed/Acceleration) on P.213 for more details.
 - (3) Please refer to P205 for performing push-motion operation.
 - (4) The service life of an actuator with lead 5 varies depending on the payload when using vertically. Please refer to P. 206 for more information.

Correlation Diagrams of Speed and Payload

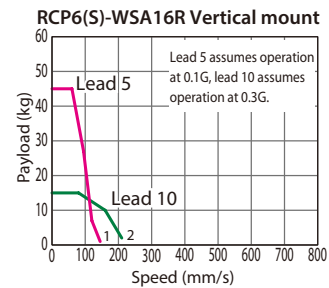
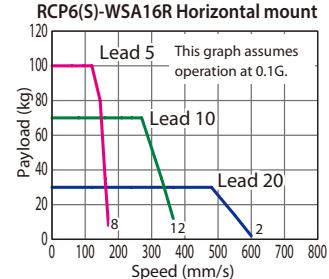

Actuator Specifications

Lead and Payload

* Push force only available during push mode w / limited speed.

Model Number	Lead (mm)	Max. Payload		Max. Push Force (N)*
		Horizontal (kg)	Vertical (kg)	
RCP6(S)-WSA16R-WA-56SP-20-①②③④	20	30	-	239
RCP6(S)-WSA16R-WA-56SP-10-①②③④	10	70	15	478
RCP6(S)-WSA16R-WA-56SP-5-①②③④	5	100	45	956

Legend: ① Stroke ② Applicable controller/I/O type ③ Cable length ④ Options

Stroke and Max. Speed

(Unit: mm/s)

Lead (mm)	50~650 (Every 50mm)	700 (mm)	750 (mm)	800 (mm)	850 (mm)	900 (mm)	950 (mm)	1,000 (mm)	1,050 (mm)	1,100 (mm)
20	600					590	535	490	450	415
10	365 <210>	355 <210>	320 <210>	290 <210>	265 <210>	240 <210>	225 <210>	205		
5	170 <145>		160 <145>		145	130	120	110	100	

Values in brackets < > are for vertical use.

① Stroke

Stroke (mm)	RCP6	RCP6S	Stroke (mm)	RCP6	RCP6S
50	○	○	600	○	○
100	○	○	650	○	○
150	○	○	700	○	○
200	○	○	750	○	○
250	○	○	800	○	○
300	○	○	850	○	○
350	○	○	900	○	○
400	○	○	950	○	○
450	○	○	1000	○	○
500	○	○	1050	○	○
550	○	○	1100	○	○

③ Cable Length

Cable Type	Cable Code	RCP6	RCP6S
Standard	P (1m)	○	○
	S (3m)	○	○
	M (5m)	○	○
Specified Length	X06 (6m) ~X10 (10m)	○	○
	X11 (11m) ~X15 (15m)	○	○
	X16 (16m) ~X20 (20m)	○	○
	R01 (1m) ~R03 (3m)	○	○
Robot Cable	R04 (4m) ~R05 (5m)	○	○
	R06 (6m) ~R10 (10m)	○	○
	R11 (11m) ~R15 (15m)	○	○
	R16 (16m) ~R20 (20m)	○	○

* Please refer to P.267 and 283 for more information regarding the maintenance cables.

④ Options

Name	Option Code	Reference Page
Brake	B	See P.189
Cable exit direction (Outside)	CJO	See P.189
Motor side-mounted to the left	ML	See P.193
Motor side-mounted to the right	MR	See P.193
Non-motor end specification	NM	See P.194
Slider roller specification	SR	See P.195

When selecting multiple options, please list them in alphabetical order. (e.g. B-CJ-B-NM)

Actuator Specifications

Item	Description
Drive system	Ball screw φ16mm, rolled C10
Positioning repeatability	±0.01mm
Lost motion	0.1mm or less
Base	Material: Aluminum with white alumite treatment
Static allowable moment	Ma: 642N·m, Mb: 642N·m, Mc: 1,610N·m
Dynamic allowable moment (*1)	Ma: 161N·m, Mb: 161N·m, Mc: 404N·m
Ambient operating temp. & humidity	0~40°C, 85% RH or less (Non-condensing)

* Reference for overhang load length: Ma: 650mm or less, Mb, Mc: 650mm or less

(*1) Assumes a standard rated life of 5,000km. The service life will vary depending on operation and installation conditions. Please refer to our website for more information regarding the directions of the allowable moment and overhang load length.



*1 When the slider is returning to its home position, please be careful of interference from surrounding objects, as it will travel until it reaches the M.E.
M.E: Mechanical end S.E: Stroke end

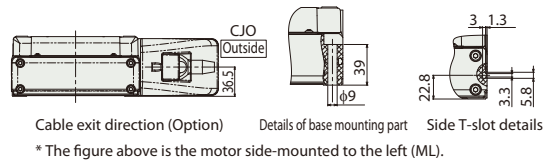
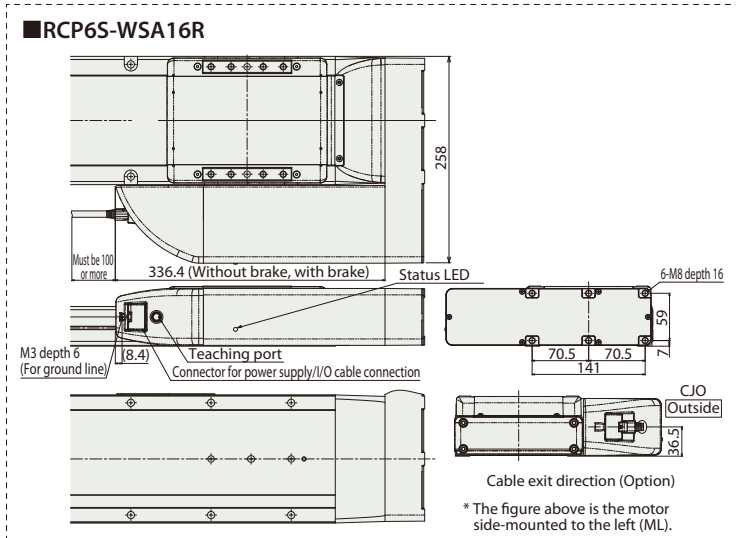
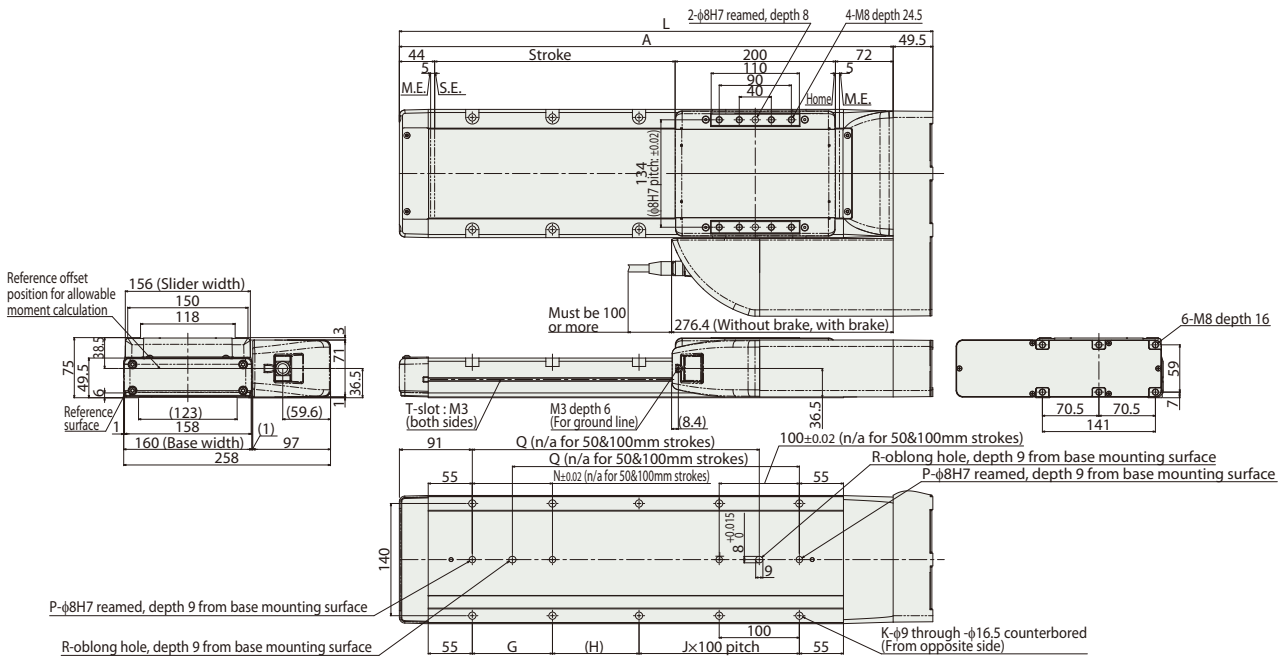

■ Dimensions and Mass by Stroke

Stroke	50	100	150	200	250	300	350	400	450	500	550	600	650	700	750	800	850	900	950	1,000	1,050	1,100		
L	415.5	465.5	515.5	565.5	615.5	665.5	715.5	765.5	815.5	865.5	915.5	965.5	1,015.5	1,065.5	1,115.5	1,165.5	1,215.5	1,265.5	1,315.5	1,365.5	1,415.5	1,465.5		
A	366	416	466	516	566	616	666	716	766	816	866	916	966	1,016	1,066	1,116	1,166	1,216	1,266	1,316	1,366	1,416		
G	-	-	100	100	100	100	100	100	100	100	100	100	100	100	100	100	100	100	100	100	100	100		
H	158	208	58	108	58	108	58	108	58	108	58	108	58	108	58	108	58	108	58	108	58	108		
J	0	0	1	1	2	2	3	3	4	4	5	5	6	6	7	7	8	8	9	9	10	10		
K	4	4	8	8	10	10	12	12	14	14	16	16	18	18	20	20	22	22	24	24	26	26		
N	-	-	100	100	100	100	100	100	100	100	100	100	100	100	100	100	100	100	100	100	100	100		
P	1	1	2	2	2	2	2	2	2	2	2	2	2	2	2	2	2	2	2	2	2	2		
Q	-	-	208	258	308	358	408	458	508	558	608	658	708	758	808	858	908	958	1,008	1,058	1,108	1,158		
R	0	0	1	1	1	1	1	1	1	1	1	1	1	1	1	1	1	1	1	1	1	1		
Mass (kg)	RCP6	w/o brake	10.4	11.0	11.6	12.2	12.7	13.3	13.9	14.5	15.1	15.7	16.3	16.9	17.5	18.1	18.7	19.3	19.9	20.5	21.0	21.7	22.2	22.8
	RCP6	w/brake	10.6	11.2	11.8	12.4	13.0	13.6	14.2	14.8	15.4	16.0	16.6	17.2	17.7	18.3	18.9	19.5	20.1	20.7	21.3	21.9	22.5	23.1
	RCP6S	w/o brake	10.6	11.2	11.8	12.4	13.0	13.6	14.2	14.8	15.4	16.0	16.6	17.2	17.7	18.4	18.9	19.5	20.1	20.7	21.3	21.9	22.5	23.1
	RCP6S	w/brake	10.9	11.5	12.1	12.7	13.3	13.9	14.4	15.0	15.6	16.2	16.8	17.4	18.0	18.6	19.2	19.8	20.4	21.0	21.6	22.2	22.7	23.4

② Applicable Controllers

The RCP6 series actuators can be operated by the controllers indicated below. Please select the type depending on your intended use. * Please refer to P.271 for more information about the built-in controller of RCP6S series.

Name	External view	Max. number of controlled axes	Input power	Control method			Maximum number of positioning points	Reference page
				Positioner	Pulse train	Program		
PCON-CFB/CGFB		1	DC24V	●	●	-	512 (768 for network spec.)	Please see P.255
				*Option	*Option			
				Control method: Network *Option DeviceNet, CompoNet, EtherNet/IP, CC-Link, MECHATROLINK, EtherCAT, PROFIBUS				

RCP6(S)-RA4C

Battery-less Absolute

Motor Unit Type

Coupled Motor

Body Width 40 mm

24v Stepper Motor

Model Specification Items

Series — Type — Encoder Type — Motor Type — Lead — Stroke — Applicable Controller/I/O Type — Cable Length — Options

RCP6: Separate Controller
RCP6S: Built-in Controller

WA: Battery-less Absolute

35P: Stepper Motor 35□ Size

16: 16mm
10: 10mm
5: 5mm
2.5: 2.5mm

50: 50mm
200: 200mm (50mm increments)

[RCP6]
P3: PCON
MCON
MSEL
P5: RCM-P6PC
[RCP6S]
SE: SIO Type

N: None
P: 1m
S: 3m
M: 5m
X□□: Specified Length
R□□: Robot Cable

Please refer to the options table below.

* RCP6 does not include a controller. RCP6S includes a built-in controller.
* Please refer to P.16 for more information about the model specification items.

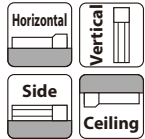

*Some limitations may apply to horizontal/side/ceiling mountings depending on the model. See page 204. Please contact IAI for more information.



Correlation Diagrams of Speed and Payload

(1) High-output enabled with PCON/MCON/MSEL connected.

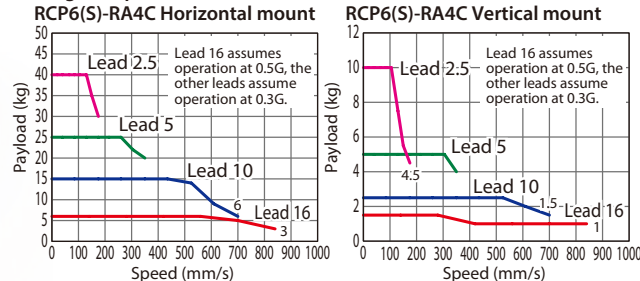

(2) High-output disabled with PCON/MCON connected.

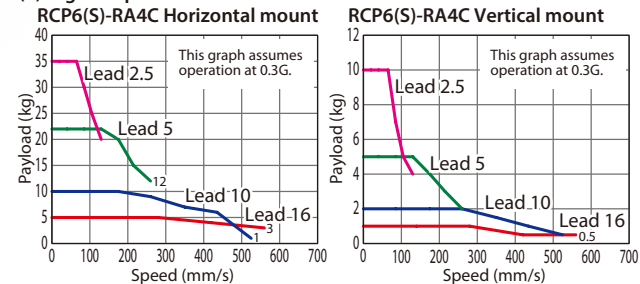

- POINT Selection Notes**
- (1) The maximum acceleration/deceleration is 1G for horizontal, and 0.5G for vertical use.
 - (2) The actuator specification displays the payload's maximum value, but it will vary depending on the acceleration and speed. Please refer to the "Selection Guidelines" (Tables of Payload by Speed/Acceleration) on P.223 for more details.
 - (3) The value of the horizontal payload assumes that there is an external guide. Please be aware that the anti-rotation stopper can be damaged when an external force is applied to the rod from any direction other than the moving direction.
 - (4) Please refer to P.205 for performing push-motion operation.

Actuator Specifications

Lead and Payload

* Push force only available during push mode w / limited speed.

Model Number	Lead (mm)	Connected Controller	Max. Payload		Max. Push Force (N)*	Stroke (mm)
			Horizontal (kg)	Vertical (kg)		
RCP6(S)-RA4C-WA-35P-16-①②③④	16	High-output Enabled	6	1.5	48	50~200 (The increment of stroke is 50mm)
		High-output Disabled	5	1		
RCP6(S)-RA4C-WA-35P-10-①②③④	10	High-output Enabled	15	2.5	77	50~200 (The increment of stroke is 50mm)
		High-output Disabled	10	2		
RCP6(S)-RA4C-WA-35P-5-①②③④	5	High-output Enabled	28	5	155	50~200 (The increment of stroke is 50mm)
		High-output Disabled	22	5		
RCP6(S)-RA4C-WA-35P-2.5-①②③④	2.5	High-output Enabled	40	10	310	50~200 (The increment of stroke is 50mm)
		High-output Disabled	35	10		

Legend: ① Stroke ② Applicable controller/I/O type ③ Cable length ④ Options

Stroke and Max. Speed

(Unit: mm/s)

Lead (mm)	Connected Controller	50~200 (Every 50mm)
16	High-output Enabled	840
	High-output Disabled	560
10	High-output Enabled	700
	High-output Disabled	525
5	High-output Enabled	350
	High-output Disabled	260
2.5	High-output Enabled	175
	High-output Disabled	130

① Stroke

Stroke (mm)	RCP6	RCP6S	Stroke (mm)	RCP6	RCP6S
50	○	○	150	○	○
100	○	○	200	○	○

④ Options

Name	Option Code	Reference Page
Brake	B	See P.189
Cable exit direction (Top)	CJT	See P.189
Cable exit direction (Right)	CJR	See P.189
Cable exit direction (Left)	CJL	See P.189
Cable exit direction (Bottom)	CJB	See P.189
Flange	FL	See P.190
Foot bracket	FT	See P.191
Tip adapter (Internal thread)	NFA	See P.193
Non-motor end specification	NM	See P.194
T-slot nut bar	NTB	See P.194

When selecting multiple options, please list them in alphabetical order. (e.g. B-CJB-NM)

③ Cable Length

Cable Type	Cable Code	RCP6			RCP6S
		P3	P5	SE	
Standard	P (1m)	○	○	○	○
	S (3m)	○	○	○	○
	M (5m)	○	○	○	○
Specified Length	X06 (6m) ~X10 (10m)	○	○	○	○
	X11 (11m) ~X15 (15m)	○	○	○	○
	X16 (16m) ~X20 (20m)	○	○	○	○
	X21 (21m) ~X25 (25m)	○	○	○	○
Robot Cable	R01 (1m) ~R03 (3m)	○	○	○	○
	R04 (4m) ~R05 (5m)	○	○	○	○
	R06 (6m) ~R10 (10m)	○	○	○	○
	R11 (11m) ~R15 (15m)	○	○	○	○
	R16 (16m) ~R20 (20m)	○	○	○	○
	R21 (21m) ~R25 (25m)	○	○	○	○

* Please refer to P.267 and 283 for more information regarding the maintenance cables.

Actuator Specifications

Item	Description
Drive system	Ball screw φ8mm, rolled C10
Positioning repeatability	±0.01mm
Lost motion	0.1mm or less
Rod	φ20mm Material: Aluminum with hard alumite treatment
Static allowable torque on rod tip	1.0N·m
Max. angular displacement on rod tip (*1)	±1.0 deg.
Ambient operating temp. & humidity	0~40°C, 85% RH or less (Non-condensing)

(*1) This is the displacement angle of the rod tip (initial reference value) when the rod is fully retracted and the static allowable torque is applied at the rod tip.

CAD drawings can be downloaded from our website.
www.intelligentactuator.com



*1 When the rod is returning to its home position, please be careful of interference from surrounding objects, as it will travel until it reaches the M.E.
M.E: Mechanical end S.E: Stroke end
*2 The direction of width across flats varies depending on the product.
Must be 100 or more

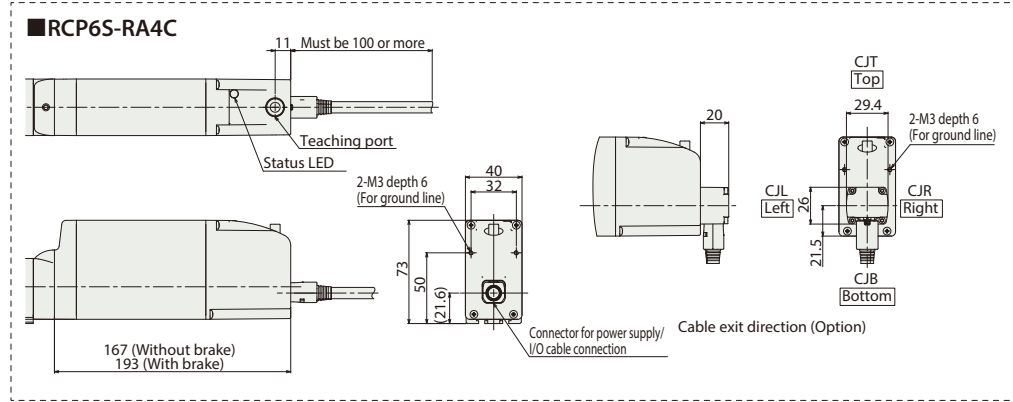
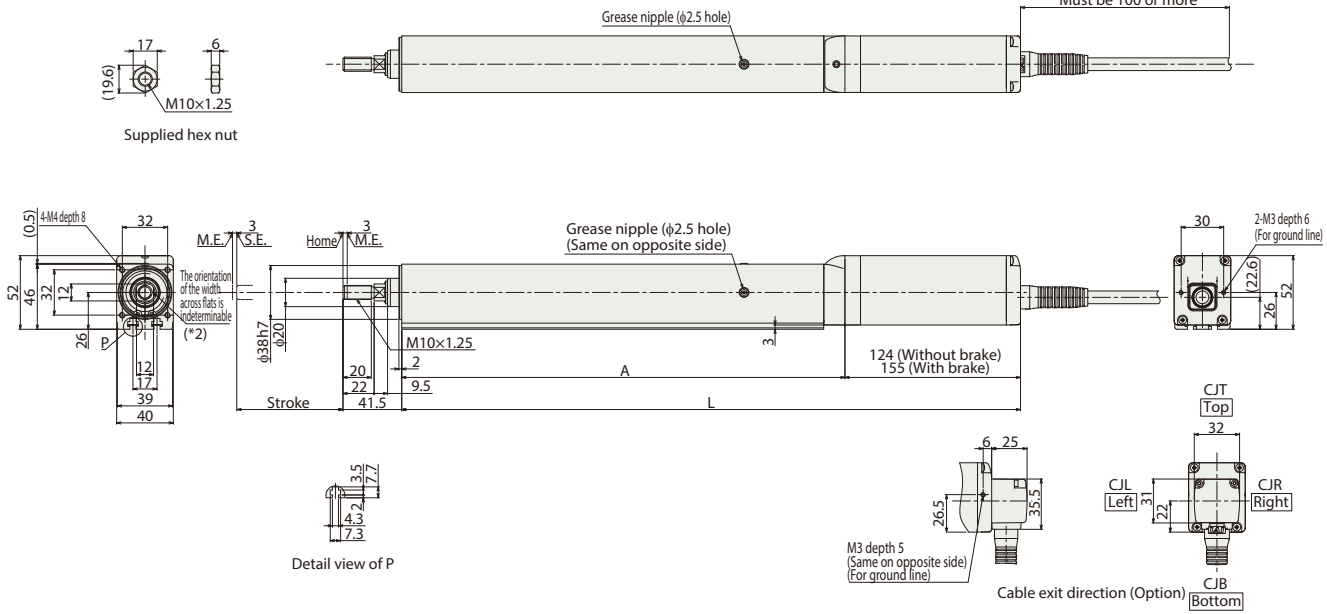

■ Dimensions and Mass by Stroke

L	Stroke	50	100	150	200	
		RCP6	w/o brake	287	337	387
	w/ brake	318	368	418	468	
RCP6S	w/o brake	330	380	430	480	
	w/ brake	356	406	456	506	
	A	163	213	263	313	
Mass (kg)	RCP6	w/o brake	1.4	1.6	1.7	1.9
		w/ brake	1.5	1.7	1.9	2.1
	RCP6S	w/o brake	1.6	1.8	1.9	2.1
		w/ brake	1.7	1.9	2.1	2.3

② Applicable Controllers

The RCP6 series actuators can be operated by the controllers indicated below. Please select the type depending on your intended use. * Please refer to P.271 for more information about the built-in controller of RCP6S series.

Name	External view	Max. number of controlled axes	Input power	Control method				Maximum number of positioning points	Reference page
				Positioner	Pulse train	Program	Network * Option		
PCON-CYB/PLB/POB		1	DC24V	●	●	—	Network cannot be selected	64	Please contact IAI for more information.
PCON-CB/CGB		1		* Option	* Option	—	DeviceNet MECHATROLINK CC-Link EtherCAT EtherNet/IP CompoNet	512	(768 for network spec.) Please see P.255
MCON-C/CG		8		This model is network-compatible only.				256	
MCON-LC/LCG		6		—	—	●	Note: The type of compatible networks will vary depending on the controller. Please refer to reference page for more information.	256	Please contact IAI for more information.
MSEL-PC/PG		4	Single-phase 100 ~ 230 VAC	—	—	●	30,000	Please contact IAI for more information.	
RCM-P6PC		1	Usable within the RCP6S Gateway system.				768	Please see P.279	

* For the MCON controller, high-output enabled operation is only available if "high-output setting" is selected as an option. The maximum connectable axes with high-output enabled are C: 4 and LC: 3.

Foreword
Slider Type
Wide Slider Type
Rod Type
Radial Cylinder
Wide Radial Cylinder
Table Type
Cleanroom Slider
Cleanroom Wide Slider
Dust/Splash-Proof Rod
Dust/Splash-Proof Radial Cylinder
Dust/Splash-Proof Wide Radial Cylinder
Options
Reference Data
Controller

RCP6(S)-RA6C

Battery-less Absolute

Motor Unit Type

Coupled Motor

Body Width 58 mm

24v Stepper Motor

Model Specification Items

Series	Type	Encoder Type	Motor Type	Lead	Stroke	Applicable Controller/I/O Type	Cable Length	Options
RA6C	WA	42P						
RCP6: Separate Controller RCP6S: Built-in Controller	WA: Battery-less Absolute	42P: Stepper Motor 42□ Size	20: 20mm 12: 12mm 6: 6mm 3: 3mm	50: 50mm 300: 300mm (50mm increments)	[RCP6] P3: PCON MCON MSEL P5: RCM-P6PC [RCP6S] SE: SIO Type	N: None P: 1m S: 3m M: 5m X□□: Specified Length R□□: Robot Cable	Please refer to the options table below.	

* RCP6 does not include a controller. RCP6S includes a built-in controller.
* Please refer to P.16 for more information about the model specification items.

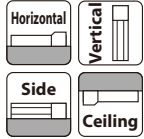

*Some limitations may apply to horizontal/side/ceiling mountings depending on the model. See page 204. Please contact IAI for more information.



Correlation Diagrams of Speed and Payload

(1) High-output enabled with PCON/MCON/MSEL connected.

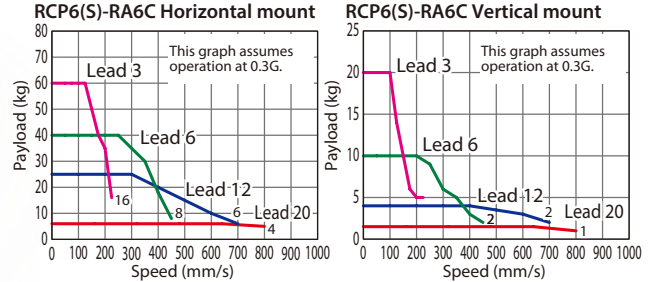

(2) High-output disabled with PCON/MCON connected.

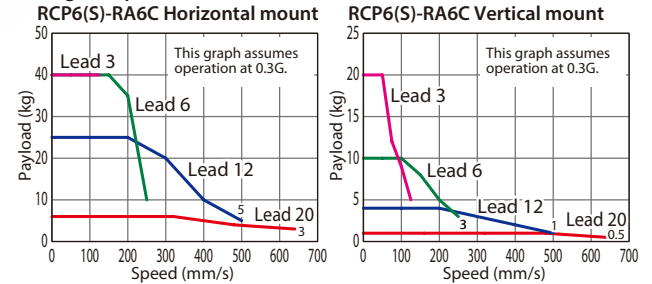

- POINT Selection Notes**
- The maximum acceleration/deceleration is 1G for horizontal, and 0.5G for vertical use.
 - The actuator specification displays the payload's maximum value, but it will vary depending on the acceleration and speed. Please refer to the "Selection Guidelines" (Tables of Payload by Speed/Acceleration) on P.223 for more details.
 - The value of the horizontal payload assumes that there is an external guide. Please be aware that the anti-rotation stopper can be damaged when an external force is applied to the rod from any direction other than the moving direction.
 - Please refer to P205 for performing push-motion operation.
 - Depending on the ambient operational temperature, duty control is necessary for the RCP6S (built-in controller type) with lead 3/6. Please refer to P.247 for more information.

Actuator Specifications

Lead and Payload

* Push force only available during push mode w / limited speed.

Model Number	Lead (mm)	Connected Controller	Max. Payload		Max. Push Force (N)*	Stroke (mm)
			Horizontal (kg)	Vertical (kg)		
RCP6(S)-RA6C-WA-42P-20-①②③④	20	High-output Enabled	6	1.5	56	50~300 (The increment of stroke is 50mm)
		High-output Disabled	6	1		
RCP6(S)-RA6C-WA-42P-12-①②③④	12	High-output Enabled	25	4	93	
		High-output Disabled	25	4		
RCP6(S)-RA6C-WA-42P-6-①②③④	6	High-output Enabled	40	10	185	
		High-output Disabled	40	10		
RCP6(S)-RA6C-WA-42P-3-①②③④	3	High-output Enabled	60	20	370	
		High-output Disabled	40	20		

Legend: ① Stroke ② Applicable controller/I/O type ③ Cable length ④ Options

Stroke and Max. Speed

(Unit: mm/s)

Lead (mm)	Connected Controller	50~300 (Every 50mm)
20	High-output Enabled	800
	High-output Disabled	640
12	High-output Enabled	700
	High-output Disabled	500
6	High-output Enabled	450
	High-output Disabled	250
3	High-output Enabled	225
	High-output Disabled	125

① Stroke

Stroke (mm)	RCP6	RCP6S	Stroke (mm)	RCP6	RCP6S
50	○	○	200	○	○
100	○	○	250	○	○
150	○	○	300	○	○

④ Options

Name	Option Code	Reference Page
Brake	B	See P.189
Cable exit direction (Top)	CJT	See P.189
Cable exit direction (Right)	CJR	See P.189
Cable exit direction (Left)	CJL	See P.189
Cable exit direction (Bottom)	CJB	See P.189
Flange	FL	See P.190
Foot bracket	FT	See P.191
Tip adapter (Internal thread)	NFA	See P.193
Non-motor end specification	NM	See P.194
T-slot nut bar	NTB	See P.194

When selecting multiple options, please list them in alphabetical order. (e.g. B-CJB-NM)

③ Cable Length

Cable Type	Cable Code	RCP6			RCP6S
		P3	P5	SE	
Standard	P (1m)	○	○	○	○
	S (3m)	○	○	○	○
	M (5m)	○	○	○	○
Specified Length	X06 (6m) ~X10 (10m)	○	○	○	○
	X11 (11m) ~X15 (15m)	○	○	○	○
	X16 (16m) ~X20 (20m)	○	○	○	○
	R01 (1m) ~R03 (3m)	○	○	○	○
Robot Cable	R04 (4m) ~R05 (5m)	○	○	○	○
	R06 (6m) ~R10 (10m)	○	○	○	○
	R11 (11m) ~R15 (15m)	○	○	○	○
	R16 (16m) ~R20 (20m)	○	○	○	○

* Please refer to P.267 and 283 for more information regarding the maintenance cables.

Actuator Specifications

Item	Description
Drive system	Ball screw φ10mm, rolled C10
Positioning repeatability	±0.01mm
Lost motion	0.1mm or less
Rod	φ25mm Material: Aluminum with hard alumite treatment
Static allowable torque on rod tip	1.5N·m
Max. angular displacement on rod tip (*1)	±1.0 deg.
Ambient operating temp. & humidity	0~40°C, 85% RH or less (Non-condensing)

(*1) This is the displacement angle of the rod tip (initial reference value) when the rod is fully retracted and the static allowable torque is applied at the rod tip.

CAD drawings can be downloaded from our website.
www.intelligentactuator.com



*1 When the rod is returning to its home position, please be careful of interference from surrounding objects, as it will travel until it reaches the M.E.
M.E: Mechanical end S.E: Stroke end
*2 The direction of width across flats varies depending on the product.

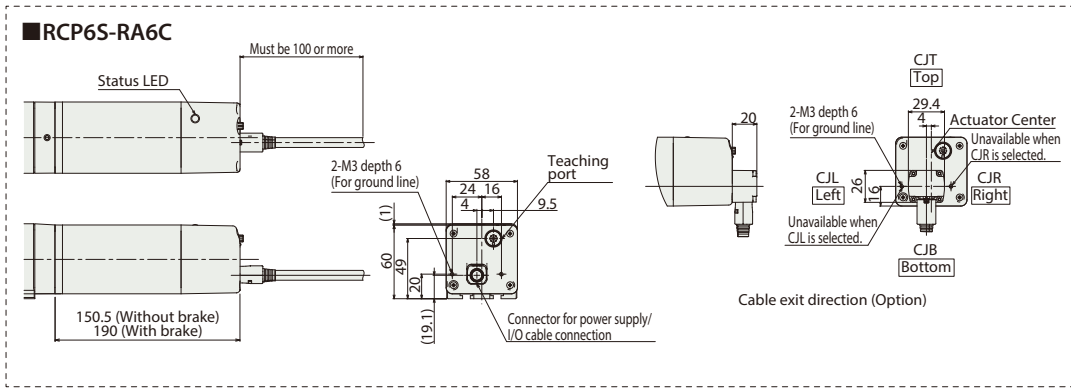
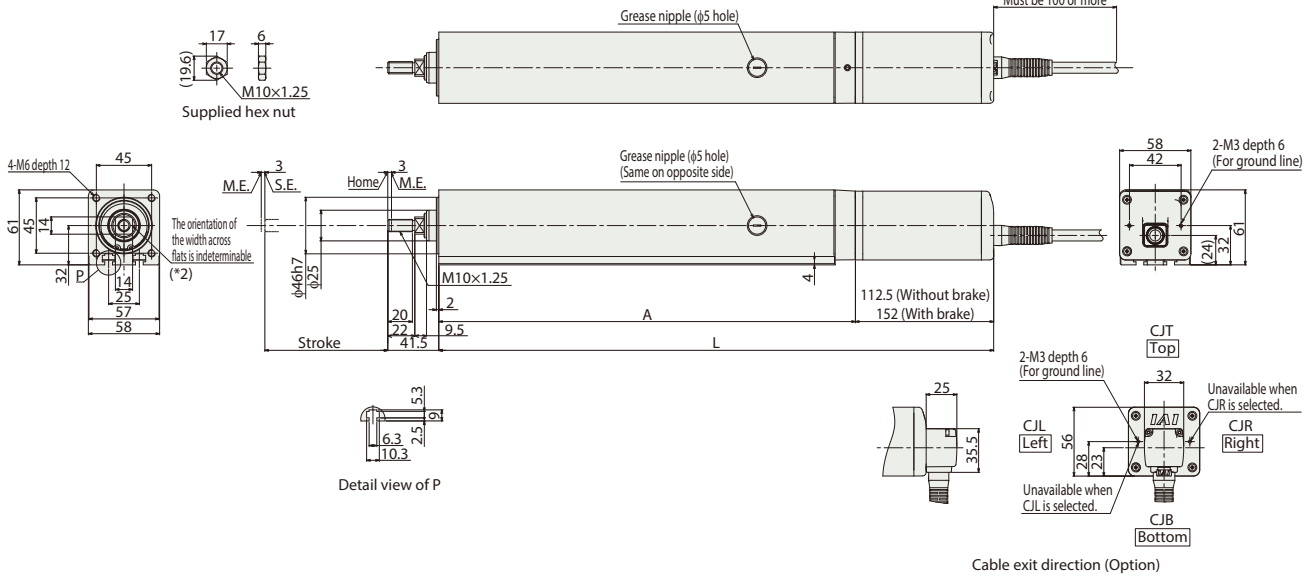

Dimensions and Mass by Stroke

L	Stroke	50	100	150	200	250	300	
		RCP6	w/o brake	301.5	351.5	401.5	451.5	501.5
	w/ brake	341	391	441	491	541	591	
	RCP6S	w/o brake	339.5	389.5	439.5	489.5	539.5	589.5
	w/ brake	379	429	479	529	579	629	
	A	189	239	289	339	389	439	
Mass (kg)	RCP6	w/o brake	2.5	2.9	3.3	3.6	4.0	4.4
	w/ brake	2.7	3.1	3.5	3.9	4.3	4.7	
	RCP6S	w/o brake	2.6	3.0	3.4	3.8	4.2	4.6
	w/ brake	2.9	3.2	3.6	4.0	4.4	4.8	

② Applicable Controllers

The RCP6 series actuators can be operated by the controllers indicated below. Please select the type depending on your intended use. * Please refer to P.271 for more information about the built-in controller of RCP6S series.

Name	External view	Max. number of controlled axes	Input power	Control method				Maximum number of positioning points	Reference page
				Positioner	Pulse train	Program	Network * Option		
PCON-CYB/PLB/POB		1	DC24V	●	●	—	Network cannot be selected	64	Please contact IAI for more information.
PCON-CB/CGB		1		* Option	* Option	—	DeviceNet MECHATROLINK CC-Link EtherCAT EtherNet/IP CompoNet	512	Please see P.255
MCON-C/CG		8		This model is network-compatible only.				256	
MCON-LC/LCG		6		—	—	●	256	Please contact IAI for more information.	
MSEL-PC/PG		4	Single-phase 100 ~ 230 VAC	—	—	●	30,000	Please contact IAI for more information.	
RCM-P6PC		1	Usable within the RCP6S Gateway system.				768	Please see P.279	

* For the MCON controller, high-output enabled operation is only available if "high-output setting" is selected as an option. The maximum connectable axes with high-output enabled are C: 4 and LC: 3.

Foreword
Slider Type
Wide Slider Type
Rod Type
Radial Cylinder
Wide Radial Cylinder
Table Type
Cleanroom Slider
Cleanroom Wide Slider
Dust/Splash-Proof Rod
Dust/Splash-Proof Radial Cylinder
Dust/Splash-Proof Wide Radial Cylinder
Options
Reference Data
Controller

RCP6(S)-RA7C

Battery-less Absolute

Motor Unit Type

Coupled Motor

Body Width 70 mm

24v Stepper Motor

Model Specification Items

Series — Type — Encoder Type — Motor Type — Lead — Stroke — Applicable Controller/I/O Type — Cable Length — Options

RCP6: Separate Controller
RCP6S: Built-in Controller

WA: Battery-less Absolute

56P: Stepper Motor
56□ Size

24: 24mm
16: 16mm
8: 8mm
4: 4mm

50: 50mm
300: 300mm (50mm increments)

[RCP6]
P3: PCON
MCON
MSEL
P5: RCM-P6PC
[RCP6S]
SE: SIO Type

N: None
P: 1m
S: 3m
M: 5m
X□□: Specified Length
R□□: Robot Cable

Please refer to the options table below.

* RCP6 does not include a controller. RCP6S includes a built-in controller.
* Please refer to P.16 for more information about the model specification items.

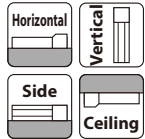

*Some limitations may apply to horizontal/side/ceiling mountings depending on the model. See page 204. Please contact IAI for more information.



- POINT Selection Notes**
- (1) The maximum acceleration/deceleration is 1G for horizontal, and 0.5G for vertical use.
 - (2) The actuator specification displays the payload's maximum value, but it will vary depending on the acceleration and speed. Please refer to the "Selection Guidelines" (Tables of Payload by Speed/Acceleration) on P.223 for more details.
 - (3) The value of the horizontal payload assumes that there is an external guide. Please be aware that the anti-rotation stopper can be damaged when an external force is applied to the rod from any direction other than the moving direction.
 - (4) Please refer to P205 for performing push-motion operation.
 - (5) Depending on the ambient operational temperature, duty control is necessary for the RCP6S (built-in controller type) with lead 4/8/16. Please refer to P.247 for more information.

Correlation Diagrams of Speed and Payload

(1) High-output enabled with PCON/MCON/MSEL connected.

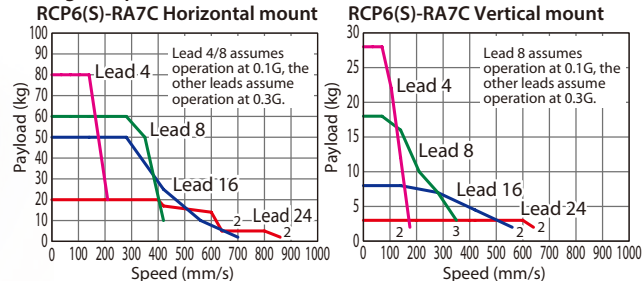

(2) High-output disabled with PCON/MCON connected.

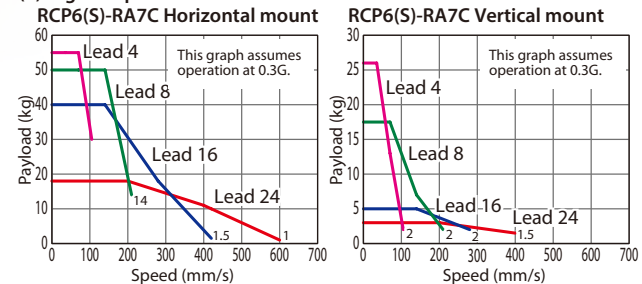

Actuator Specifications

Lead and Payload

* Push force only available during push mode w / limited speed.

Model Number	Lead (mm)	Connected Controller	Max. Payload		Max. Push Force (N)*	Stroke (mm)
			Horizontal (kg)	Vertical (kg)		
RCP6(S)-RA7C-WA-56P-24-①-②-③-④	24	High-output Enabled	20	3	182	50~300 (The increment of stroke is 50mm)
		High-output Disabled	18	3		
RCP6(S)-RA7C-WA-56P-16-①-②-③-④	16	High-output Enabled	50	8	273	50~300 (The increment of stroke is 50mm)
		High-output Disabled	40	5		
RCP6(S)-RA7C-WA-56P-8-①-②-③-④	8	High-output Enabled	60	18	547	50~300 (The increment of stroke is 50mm)
		High-output Disabled	50	17.5		
RCP6(S)-RA7C-WA-56P-4-①-②-③-④	4	High-output Enabled	80	28	1,094	50~300 (The increment of stroke is 50mm)
		High-output Disabled	55	26		

Legend: ① Stroke ② Applicable controller/I/O type ③ Cable length ④ Options

Stroke and Max. Speed

(Unit: mm/s)

Lead (mm)	Connected Controller	50~300 (Every 50mm)
24	High-output Enabled	860 <640>
	High-output Disabled	600 <400>
16	High-output Enabled	700 <560>
	High-output Disabled	420 <280>
8	High-output Enabled	420 <350>
	High-output Disabled	210
4	High-output Enabled	210 <175>
	High-output Disabled	105

Values in brackets < > are for vertical use.

① Stroke

Stroke (mm)	RCP6	RCP6S	Stroke (mm)	RCP6	RCP6S
50	○	○	200	○	○
100	○	○	250	○	○
150	○	○	300	○	○

④ Options

Name	Option Code	Reference Page
Brake	B	See P.189
Cable exit direction (Top)	CJT	See P.189
Cable exit direction (Right)	CJR	See P.189
Cable exit direction (Left)	CJL	See P.189
Cable exit direction (Bottom)	CJB	See P.189
Flange	FL	See P.190
Foot bracket	FT	See P.191
Tip adapter (Internal thread)	NFA	See P.193
Non-motor end specification	NM	See P.194
T-slot nut bar	NTB	See P.194

When selecting multiple options, please list them in alphabetical order. (e.g. B-CJB-NM)

③ Cable Length

Cable Type	Cable Code	RCP6			RCP6S
		P3	P5	SE	
Standard	P (1m)	○	○	○	○
	S (3m)	○	○	○	○
	M (5m)	○	○	○	○
Specified Length	X06 (6m) ~X10 (10m)	○	○	○	○
	X11 (11m) ~X15 (15m)	○	○	○	○
	X16 (16m) ~X20 (20m)	○	○	○	○
	R01 (1m) ~R03 (3m)	○	○	○	○
Robot Cable	R04 (4m) ~R05 (5m)	○	○	○	○
	R06 (6m) ~R10 (10m)	○	○	○	○
	R11 (11m) ~R15 (15m)	○	○	○	○
	R16 (16m) ~R20 (20m)	○	○	○	○
	R16 (16m) ~R20 (20m)	○	○	○	○

* Please refer to P.267 and 283 for more information regarding the maintenance cables.

Actuator Specifications

Item	Description
Drive system	Ball screw φ12mm, rolled C10
Positioning repeatability	±0.01mm
Lost motion	0.1mm or less
Rod	φ30mm Material: Aluminum with hard alumite treatment
Static allowable torque on rod tip	2.5N·m
Max. angular displacement on rod tip (*1)	±0.8 deg.
Ambient operating temp. & humidity	0~40°C, 85% RH or less (Non-condensing)

(*1) This is the displacement angle of the rod tip (initial reference value) when the rod is fully retracted and the static allowable torque is applied at the rod tip.

CAD drawings can be downloaded from our website.
www.intelligentactuator.com



*1 When the rod is returning to its home position, please be careful of interference from surrounding objects, as it will travel until it reaches the M.E.
M.E: Mechanical end S.E: Stroke end
*2 The direction of width across flats varies depending on the product.

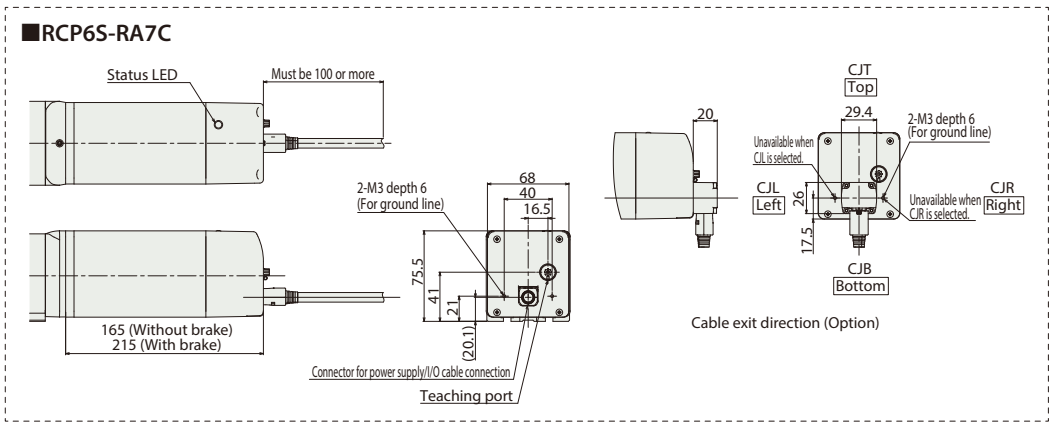
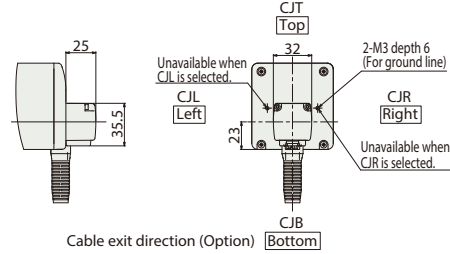
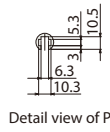
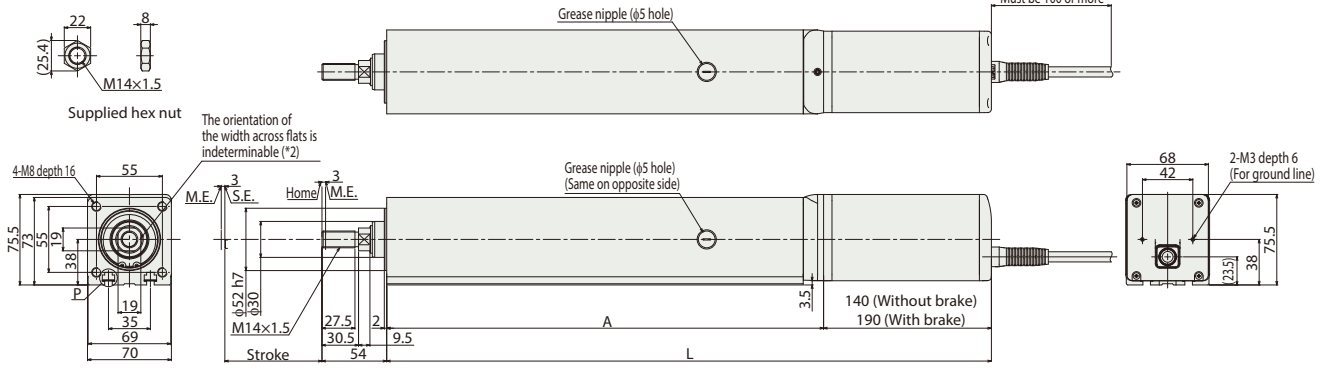

■ Dimensions and Mass by Stroke

L	Stroke	Stroke					
		50	100	150	200	250	300
RCP6	w/o brake	354.5	404.5	454.5	504.5	554.5	604.5
	w/ brake	404.5	454.5	504.5	554.5	604.5	654.5
RCP6S	w/o brake	379.5	429.5	479.5	529.5	579.5	629.5
	w/ brake	429.5	479.5	529.5	579.5	629.5	679.5
A		214.5	264.5	314.5	364.5	414.5	464.5
Mass (kg)	RCP6	4.5	5.1	5.6	6.2	6.7	7.3
	w/ brake	4.9	5.5	6.0	6.6	7.2	7.7
	RCP6S	4.7	5.2	5.8	6.3	6.9	7.5
	w/ brake	5.1	5.7	6.2	6.8	7.3	7.9

② Applicable Controllers

The RCP6 series actuators can be operated by the controllers indicated below. Please select the type depending on your intended use. * Please refer to P.271 for more information about the built-in controller of RCP6S series.

Name	External view	Max. number of controlled axes	Input power	Control method				Maximum number of positioning points	Reference page
				Positioner	Pulse train	Program	Network * Option		
PCON-CYB/PLB/POB		1	DC24V	●	●	—	Network cannot be selected	64	Please contact IAI for more information.
PCON-CB/CGB		1		* Option	* Option	—	DeviceNet MECHATROLINK CC-Link EtherCAT EtherNet/IP CompoNet	512	Please see P.255
MCON-C/CG		8		This model is network-compatible only.				256	
MCON-LC/LCG		6		—	—	●	Note: The type of compatible networks will vary depending on the controller. Please refer to reference page for more information.	256	Please contact IAI for more information.
MSEL-PC/PG		4	Single-phase 100 ~ 230 VAC	—	—	●		30,000	Please contact IAI for more information.
RCM-P6PC		1		Usable within the RCP6S Gateway system.				768	Please see P.279

* For the MCON controller, high-output enabled operation is only available if "high-output setting" is selected as an option. The maximum connectable axes with high-output enabled are C: 4 and LC: 3.

Foreword
Slider Type
Wide Slider Type
Rod Type
Radial Cylinder
Wide Radial Cylinder
Table Type
Cleanroom Slider
Cleanroom Wide Slider
Dust/Splash-Proof Rod
Dust/Splash-Proof Radial Cylinder
Dust/Splash-Proof Wide Radial Cylinder
Options
Reference Data
Controller

RCP6(S)-RA8C

Battery-less Absolute Motor Unit Type Coupled Motor Body Width 85 mm 24v Stepper Motor

Model Specification Items	Series	Type	Encoder Type	Motor Type	Lead	Stroke	Applicable Controller/I/O Type	Cable Length	Options
	RA8C	WA	60P						
	RCP6: Separate Controller RCP6S: Built-in Controller	WA: Battery-less Absolute	60P: Stepper Motor 60□ Size	20: 20mm 10: 10mm 5: 5mm	50: 50mm 1 300: 300mm (50mm increments)	[RCP6] P4: PCON-CFB/CGFB [RCP6S] SE: SIO Type	N : None P : 1m S : 3m M : 5m X□□ : Specified Length R□□ : Robot Cable	Please refer to the options table below.	

* RCP6 does not include a controller. RCP6S includes a built-in controller.
* Please refer to P.16 for more information about the model specification items.

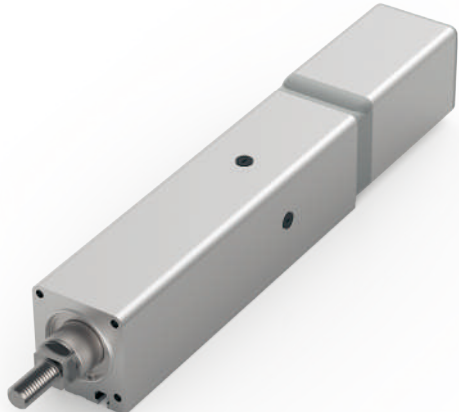
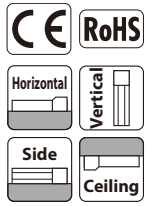

*Some limitations may apply to horizontal/side/ceiling mountings depending on the model. See page 204. Please contact IAI for more information.

- POINT Selection Notes**
- (1) The maximum acceleration/deceleration is 0.1G for lead 5 and 0.2G for lead 10/20.
 - (2) The actuator specification displays the payload's maximum value, but it will vary depending on the acceleration and speed. Please refer to the "Selection Guidelines" (Tables of Payload by Speed/Acceleration) on P.223 for more details.
 - (3) The value of the horizontal payload assumes that there is an external guide. Please be aware that the anti-rotation stopper can be damaged when an external force is applied to the rod from any direction other than the moving direction.
 - (4) Please refer to P205 for performing push-motion operation.
 - (5) For RCP6S (built-in controller type), please limit the duty cycle to 70% or less.
 - (6) The service life of an actuator varies depending on the payload when using vertically. Please refer to P. 206 for more information.

Correlation Diagrams of Speed and Payload PCON connected.

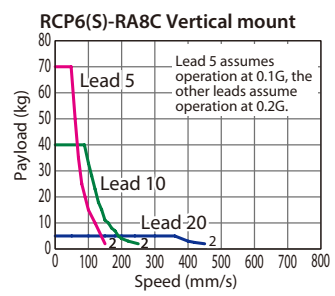
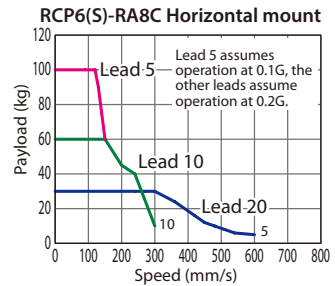

Actuator Specifications

Model Number	Lead (mm)	Max. Payload		Max. Push Force (N)*	Stroke (mm)	Stroke and Max. Speed (Unit: mm/s)	
		Horizontal (kg)	Vertical (kg)			Lead (mm)	50~300 (Every 50mm)
RCP6(S)-RA8C-WA-60P-20-①-②-③-④	20	30	5	500	50~300 (The increment of stroke is 50mm)	20	600 <450>
RCP6(S)-RA8C-WA-60P-10-①-②-③-④	10	60	40	1,000		10	300 <250>
RCP6(S)-RA8C-WA-60P-5-①-②-③-④	5	100	70	2,000		5	150

* Push force only available during push mode w / limited speed.

Legend: ① Stroke ② Applicable controller/I/O type ③ Cable length ④ Options Values in brackets < > are for vertical use.

① Stroke

Stroke (mm)	RCP6	RCP6S	Stroke (mm)	RCP6	RCP6S
50	○	○	200	○	○
100	○	○	250	○	○
150	○	○	300	○	○

④ Options

Name	Option Code	Reference Page
Brake	B	See P.189
Cable exit direction (Top)	CJT	See P.189
Cable exit direction (Right)	CJR	See P.189
Cable exit direction (Left)	CJL	See P.189
Cable exit direction (Bottom)	CJB	See P.189
Flange	FL	See P.190
Foot bracket	FT	See P.191
Tip adapter (Internal thread)	NFA	See P.193
Non-motor end specification	NM	See P.194
T-slot nut bar	NTB	See P.194

When selecting multiple options, please list them in alphabetical order. (e.g. B-CJB-NM)

③ Cable Length

Cable Type	Cable Code	RCP6	RCP6S
Standard	P (1m)	○	○
	S (3m)	○	○
	M (5m)	○	○
Specified Length	X06 (6m) ~X10 (10m)	○	○
	X11 (11m) ~X15 (15m)	○	○
	X16 (16m) ~X20 (20m)	○	○
	R01 (1m) ~R03 (3m)	○	○
Robot Cable	R04 (4m) ~R05 (5m)	○	○
	R06 (6m) ~R10 (10m)	○	○
	R11 (11m) ~R15 (15m)	○	○
	R16 (16m) ~R20 (20m)	○	○

* Please refer to P.267 and 283 for more information regarding the maintenance cables.

Actuator Specifications

Item	Description
Drive system	Ball screw φ16mm, rolled C10
Positioning repeatability	±0.01mm
Lost motion	0.1mm or less
Rod	φ40mm Material: Aluminum with hard alumite treatment
Static allowable torque on rod tip	5N·m
Max. angular displacement on rod tip (*1)	±0.8 deg.
Ambient operating temp. & humidity	0~40°C, 85% RH or less (Non-condensing)

(*1) This is the displacement angle of the rod tip (initial reference value) when the rod is fully retracted and the static allowable torque is applied at the rod tip.

CAD drawings can be downloaded from our website.
www.intelligentactuator.com



- *1 When the rod is returning to its home position, please be careful of interference from surrounding objects, as it will travel until it reaches the M.E.
M.E: Mechanical end S.E: Stroke end
- *2 The direction of width across flats varies depending on the product.

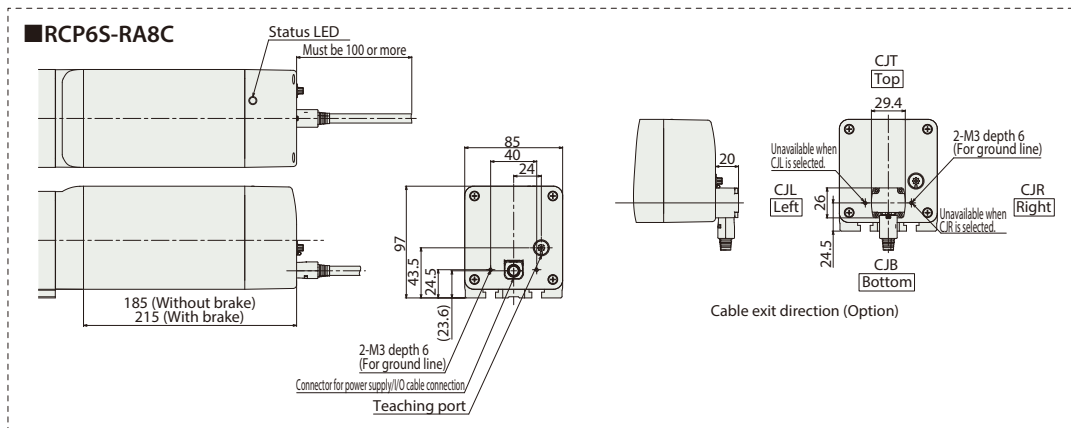
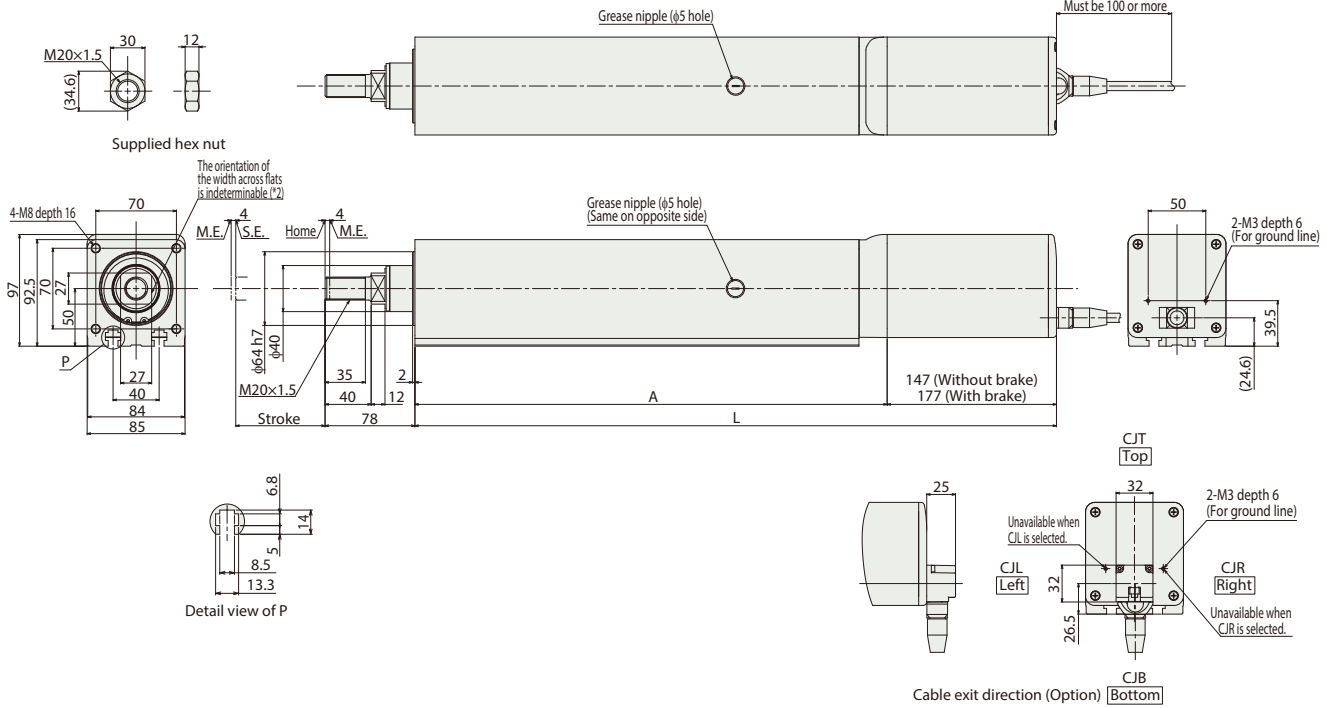

■ Dimensions and Mass by Stroke

		Stroke	50	100	150	200	250	300
L	RCP6	w/o brake	407	457	507	557	607	657
	RCP6	w/ brake	437	487	537	587	637	687
	RCP6S	w/o brake	445	495	545	595	645	695
	RCP6S	w/ brake	475	525	575	625	675	725
A			260	310	360	410	460	510
Mass (kg)	RCP6	w/o brake	7.8	8.6	9.5	10.3	11.1	11.9
	RCP6	w/ brake	8.4	9.2	10.0	10.9	11.7	12.5
	RCP6S	w/o brake	8.1	9.0	9.8	10.6	11.4	12.3
	RCP6S	w/ brake	8.7	9.5	10.4	11.2	12.0	12.8

② Applicable Controllers

The RCP6 series actuators can be operated by the controllers indicated below. Please select the type depending on your intended use.* Please refer to P.271 for more information about the built-in controller of RCP6S series.

Name	External view	Max. number of controlled axes	Input power	Control method			Maximum number of positioning points	Reference page
				Positioner	Pulse train	Program		
PCON-CFB/CGFB		1	DC24V	●	●	-	512 (768 for network spec.)	Please see P.255
				*Option	*Option			
Control method Network * Option DeviceNet CompoNet EtherNet/IP CC-Link MECHATROLINK EtherCAT 								

Foreword
Slider Type
Wide Slider Type
Rod Type
Radial Cylinder
Wide Radial Cylinder
Table Type
Cleanroom Slider
Cleanroom Wide Slider
Dust/Splash-Proof Rod
Dust/Splash-Proof Radial Cylinder
Dust/Splash-Proof Wide Radial Cylinder
Options
Reference Data
Controller

RCP6(S)-RA4R

Battery-less Absolute

Motor Unit Type

Side-mounted Motor

Body Width 40mm*

24v Stepper Motor

Model Specification Items

Series — Type — Encoder Type — Motor Type — Lead — Stroke — Applicable Controller/I/O Type — Cable Length — Options

RCP6: Separate Controller
RCP6S: Built-in Controller

WA: Battery-less Absolute

35P: Stepper Motor 35□ Size

16: 16mm
10: 10mm
5: 5mm
2.5: 2.5mm

50: 50mm
200: 200mm (50mm increments)

[RCP6]
P3: PCON
MCON
MSEL
P5: RCM-P6PC
[RCP6S]
SE: SIO Type

N: None
P: 1m
S: 3m
M: 5m
X□□: Specified Length
R□□: Robot Cable

Please refer to the options table below.
*Please make sure to specify ML, MR or MT when ordering the side-mounted motor type.

* Body width does not include the width of the side-mounted motor.

* RCP6 does not include a controller. RCP6S includes a built-in controller.
* Please refer to P.16 for more information about the model specification items.

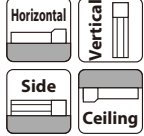

*Some limitations may apply to horizontal/side/ceiling mountings depending on the model. See page 204. Please contact IAI for more information.



The figure above is the motor side-mounted to the left (ML).

- POINT Selection Notes**
- (1) The maximum acceleration/deceleration is 1G for horizontal, and 0.5G for vertical use.
 - (2) The actuator specification displays the payload's maximum value, but it will vary depending on the acceleration and speed. Please refer to the "Selection Guidelines" (Tables of Payload by Speed/Acceleration) on P.225 for more details.
 - (3) The value of the horizontal payload assumes that there is an external guide. Please be aware that the anti-rotation stopper can be damaged when an external force is applied to the rod from any direction other than the moving direction.
 - (4) Please refer to P205 for performing push-motion operation.

Correlation Diagrams of Speed and Payload

(1) High-output enabled with PCON/MCON/MSEL connected.

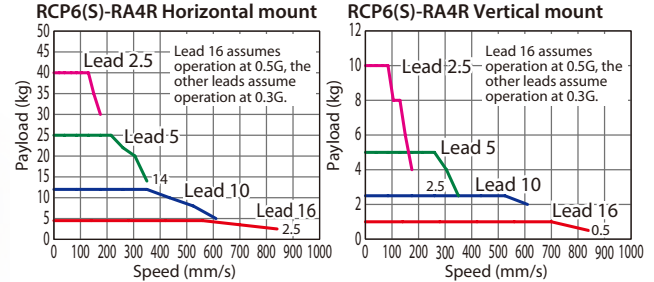

(2) High-output disabled with PCON/MCON connected.

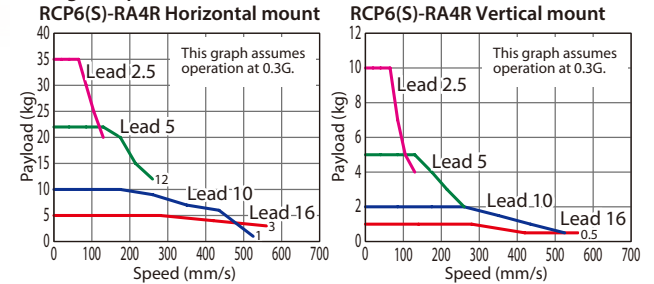

Actuator Specifications

Lead and Payload

* Push force only available during push mode w / limited speed.

Model Number	Lead (mm)	Connected Controller	Max. Payload		Max. Push Force (N)*	Stroke (mm)
			Horizontal (kg)	Vertical (kg)		
RCP6(S)-RA4R-WA-35P-16-①②③④	16	High-output Enabled	5	1	48	50~200 (The increment of stroke is 50mm)
		High-output Disabled	5	1		
RCP6(S)-RA4R-WA-35P-10-①②③④	10	High-output Enabled	12	2.5	77	50~200 (The increment of stroke is 50mm)
		High-output Disabled	10	2		
RCP6(S)-RA4R-WA-35P-5-①②③④	5	High-output Enabled	25	5	155	50~200 (The increment of stroke is 50mm)
		High-output Disabled	22	5		
RCP6(S)-RA4R-WA-35P-2.5-①②③④	2.5	High-output Enabled	40	10	310	50~200 (The increment of stroke is 50mm)
		High-output Disabled	35	10		

Legend: ① Stroke ② Applicable controller/I/O type ③ Cable length ④ Options

Stroke and Max. Speed

(Unit: mm/s)

Lead (mm)	Connected Controller	50~200 (Every 50mm)
16	High-output Enabled	840
	High-output Disabled	560
10	High-output Enabled	610
	High-output Disabled	525
5	High-output Enabled	350
	High-output Disabled	260
2.5	High-output Enabled	175
	High-output Disabled	130

① Stroke

Stroke (mm)	RCP6	RCP6S	Stroke (mm)	RCP6	RCP6S
50	○	○	150	○	○
100	○	○	200	○	○

④ Options

Name	Option Code	Reference Page
Brake	B	See P.189
Cable exit direction (Outside)	CJO	See P.189
Flange	FL	See P.190
Foot bracket	FT	See P.191
Motor side-mounted to the left	ML	See P.193
Motor side-mounted to the right	MR	See P.193
Motor side-mounted to the top	MT	See P.193
Tip adapter (Internal thread)	NFA	See P.193
Non-motor end specification	NM	See P.194
T-slot nut bar	NTB	See P.194

* Be sure to confirm with the "Selection Notes (P.196)" when selecting options.
When selecting multiple options, please list them in alphabetical order. (e.g. B-CJB-NM)

③ Cable Length

Cable Type	Cable Code	RCP6		RCP6S
		P3	P5	SE
Standard	P (1m)	○	○	○
	S (3m)	○	○	○
	M (5m)	○	○	○
Specified Length	X06 (6m) ~X10 (10m)	○	○	○
	X11 (11m) ~X15 (15m)	○	○	○
	X16 (16m) ~X20 (20m)	○	○	○
	X21 (21m) ~X25 (25m)	○	○	○
Robot Cable	R01 (1m) ~R03 (3m)	○	○	○
	R04 (4m) ~R05 (5m)	○	○	○
	R06 (6m) ~R10 (10m)	○	○	○
	R11 (11m) ~R15 (15m)	○	○	○
	R16 (16m) ~R20 (20m)	○	○	○
	R21 (21m) ~R25 (25m)	○	○	○

* Please refer to P.267 and 283 for more information regarding the maintenance cables.

Actuator Specifications

Item	Description
Drive system	Ball screw φ8mm, rolled C10
Positioning repeatability	±0.01mm
Lost motion	0.1mm or less
Rod	φ20mm Material: Aluminum with hard alumite treatment
Static allowable torque on rod tip	1.0N·m
Max. angular displacement on rod tip (*1)	±1.0 deg.
Ambient operating temp. & humidity	0~40°C, 85% RH or less (Non-condensing)

(*1) This is the displacement angle of the rod tip (initial reference value) when the rod is fully retracted and the static allowable torque is applied at the rod tip.



*1 When the rod is returning to its home position, please be careful of interference from surrounding objects, as it will travel until it reaches the M.E.
M.E: Mechanical end S.E: Stroke end

*2 The direction of width across flats varies depending on the product.
Grease nipple (φ2.5 hole)
(Top and side)

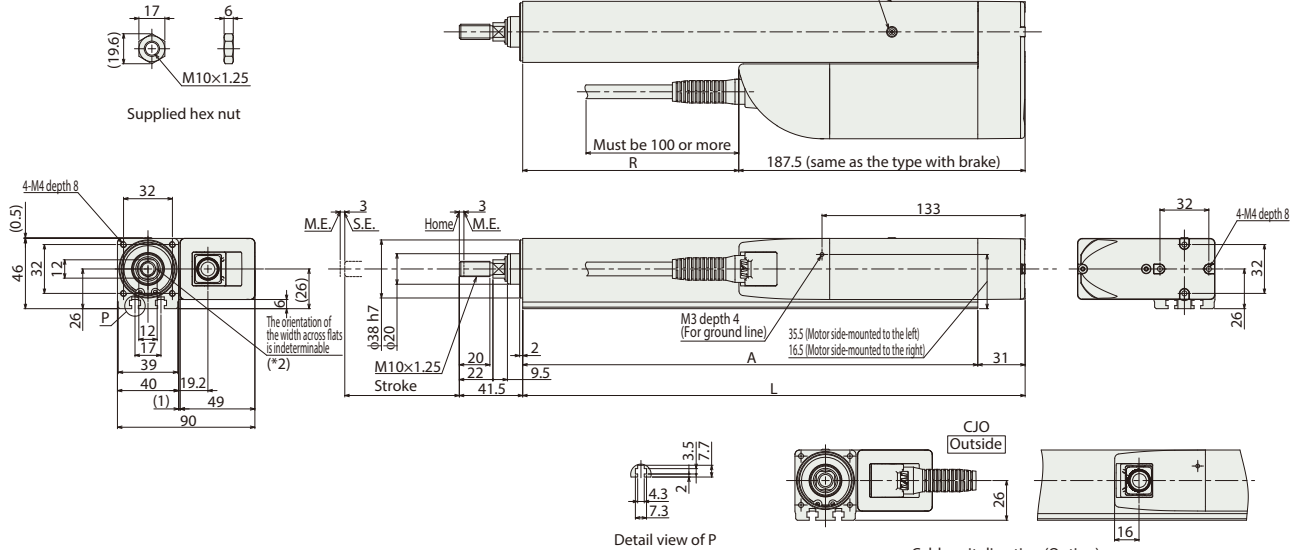

Cable exit direction (Option)
* The figure above is the motor side-mounted to the left (ML).

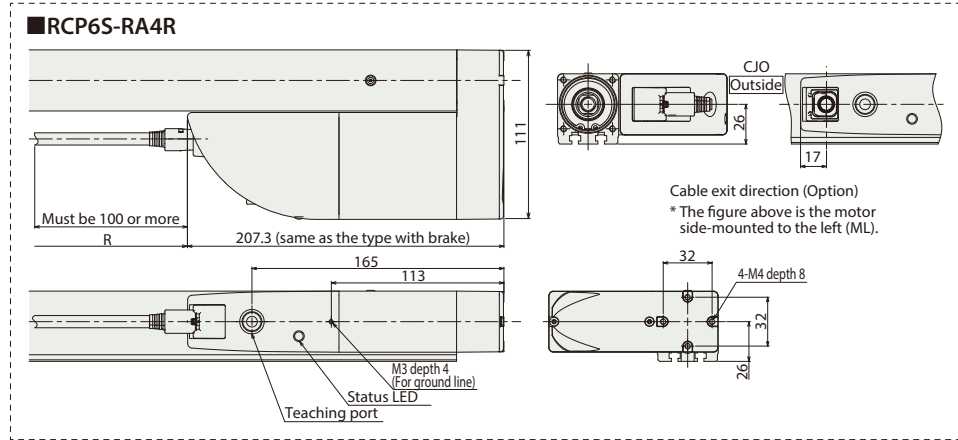

Note:
* If the length for R is negative in the table below, the length of the actuator body is shorter than the motor unit.

■ Dimensions and Mass by Stroke

Stroke	50	100	150	200		
L	179	229	279	329		
A	148	198	248	298		
R	RCP6	-8.5	41.5	91.5	141.5	
	RCP6S	-28.3	21.7	71.7	121.7	
Mass (kg)	RCP6	w/o brake	1.5	1.7	1.9	2.1
		w/brake	1.6	1.8	2	2.2
	RCP6S	w/o brake	1.6	1.8	2	2.2
		w/brake	1.7	1.9	2.1	2.3

② Applicable Controllers

The RCP6 series actuators can be operated by the controllers indicated below. Please select the type depending on your intended use. * Please refer to P.271 for more information about the built-in controller of RCP6S series.

Name	External view	Max. number of controlled axes	Input power	Control method				Maximum number of positioning points	Reference page
				Positioner	Pulse train	Program	Network * Option		
PCON-CYB/PLB/POB		1	DC24V	●	●	—	Network cannot be selected	64	Please contact IAI for more information.
PCON-CB/CGB		1		* Option	* Option	—	DeviceNet MECHATROLINK CC-Link EtherCAT EtherNet/IP CANopen CompoNet	512	(768 for network spec.)
MCON-C/CG		8		This model is network-compatible only.				256	
MCON-LC/LCG		6		—	—	●	256	Please contact IAI for more information.	
MSEL-PC/PG		4	Single-phase 100 ~ 230 VAC	—	—	●	30,000	Please contact IAI for more information.	
RCM-P6PC		1	Usable within the RCP6S Gateway system.				768	Please see P.279	

* For the MCON controller, high-output enabled operation is only available if "high-output setting" is selected as an option. The maximum connectable axes with high-output enabled are C: 4 and LC: 3.

Foreword
Slider Type
Wide Slider Type
Rod Type
Radial Cylinder
Wide Radial Cylinder
Table Type
Cleanroom Slider
Cleanroom Wide Slider
Dust/Splash-Proof Rod
Dust/Splash-Proof Radial Cylinder
Dust/Splash-Proof Wide Radial Cylinder
Options
Reference Data
Controller

RCP6(S)-RA6R

Battery-less Absolute

Motor Unit Type

Side-mounted Motor

Body Width 58* mm

24v Stepper Motor

Model Specification Items

Series — **RA6R** — Type — **WA** — Encoder Type — **42P** — Lead — Stroke — Applicable Controller/I/O Type — Cable Length — Options

RCP6: Separate Controller
RCP6S: Built-in Controller

WA: Battery-less Absolute

42P: Stepper Motor 42□ Size

20: 20mm
12: 12mm
6: 6mm
3: 3mm

50: 50mm
300: 300mm (50mm increments)

[RCP6]
P3: PCON
MCON
MSEL
P5: RCM-P6PC
[RCP6S]
SE: SIO Type

N: None
P: 1m
S: 3m
M: 5m
X□□: Specified Length
R□□: Robot Cable

Please refer to the options table below.

*Please make sure to specify ML, MR or MT when ordering the side-mounted motor type.

* Body width does not include the width of the side-mounted motor.

* RCP6 does not include a controller. RCP6S includes a built-in controller.
* Please refer to P.16 for more information about the model specification items.

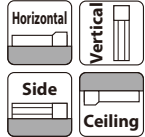

*Some limitations may apply to horizontal/side/ceiling mountings depending on the model. See page 204. Please contact IAI for more information.



The figure above is the motor side-mounted to the left (ML).

POINT Selection Notes

- (1) The maximum acceleration/deceleration is 1G for horizontal, and 0.5G for vertical use.
- (2) The actuator specification displays the payload's maximum value, but it will vary depending on the acceleration and speed. Please refer to the "Selection Guidelines" (Tables of Payload by Speed/Acceleration) on P.225 for more details.
- (3) The value of the horizontal payload assumes that there is an external guide. Please be aware that the anti-rotation stopper can be damaged when an external force is applied to the rod from any direction other than the moving direction.
- (4) Please refer to P205 for performing push-motion operation.
- (5) Depending on the ambient operational temperature, duty control is necessary for the RCP6S (built-in controller type) with lead 3/6. Please refer to P.247 for more information.

Correlation Diagrams of Speed and Payload

(1) High-output enabled with PCON/MCON/MSEL connected.

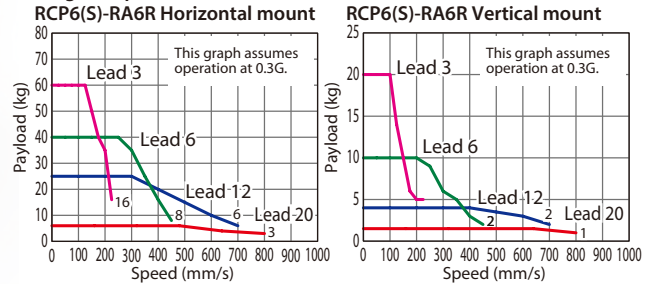

(2) High-output disabled with PCON/MCON connected.

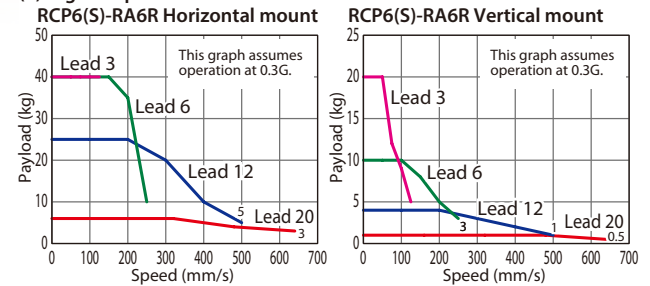

Actuator Specifications

Lead and Payload

* Push force only available during push mode w / limited speed.

Model Number	Lead (mm)	Connected Controller	Max. Payload		Max. Push Force (N)*	Stroke (mm)
			Horizontal (kg)	Vertical (kg)		
RCP6(S)-RA6R-WA-42P-20-①-②-③-④	20	High-output Enabled	6	1.5	56	50~300 (The increment of stroke is 50mm)
		High-output Disabled	6	1		
RCP6(S)-RA6R-WA-42P-12-①-②-③-④	12	High-output Enabled	25	4	93	50~300 (The increment of stroke is 50mm)
		High-output Disabled	25	4		
RCP6(S)-RA6R-WA-42P-6-①-②-③-④	6	High-output Enabled	40	10	185	50~300 (The increment of stroke is 50mm)
		High-output Disabled	40	10		
RCP6(S)-RA6R-WA-42P-3-①-②-③-④	3	High-output Enabled	60	20	370	50~300 (The increment of stroke is 50mm)
		High-output Disabled	40	20		

Legend: ① Stroke ② Applicable controller/I/O type ③ Cable length ④ Options

Stroke and Max. Speed

(Unit: mm/s)

Lead (mm)	Connected Controller	50~300 (Every 50mm)
20	High-output Enabled	800
	High-output Disabled	640
12	High-output Enabled	700
	High-output Disabled	500
6	High-output Enabled	450
	High-output Disabled	250
3	High-output Enabled	225
	High-output Disabled	125

① Stroke

Stroke (mm)	RCP6	RCP6S	Stroke (mm)	RCP6	RCP6S
50	○	○	200	○	○
100	○	○	250	○	○
150	○	○	300	○	○

④ Options

Name	Option Code	Reference Page
Brake	B	See P.189
Cable exit direction (Outside)	CJO	See P.189
Flange	FL	See P.190
Foot bracket	FT	See P.191
Motor side-mounted to the left	ML	See P.193
Motor side-mounted to the right	MR	See P.193
Motor side-mounted to the top	MT	See P.193
Tip adapter (Internal thread)	NFA	See P.193
Non-motor end specification	NM	See P.194
T-slot nut bar	NTB	See P.194

* Be sure to confirm with the "Selection Notes (P.196)" when selecting options.
When selecting multiple options, please list them in alphabetical order. (e.g. B-CJB-NM)

③ Cable Length

Cable Type	Cable Code	RCP6			RCP6S
		P3	P5	SE	
Standard	P (1m)	○	○	○	○
	S (3m)	○	○	○	○
	M (5m)	○	○	○	○
Specified Length	X06 (6m) ~X10 (10m)	○	○	○	○
	X11 (11m) ~X15 (15m)	○	○	○	○
	X16 (16m) ~X20 (20m)	○	○	○	○
	R01 (1m) ~R03 (3m)	○	○	○	○
Robot Cable	R04 (4m) ~R05 (5m)	○	○	○	○
	R06 (6m) ~R10 (10m)	○	○	○	○
	R11 (11m) ~R15 (15m)	○	○	○	○
	R16 (16m) ~R20 (20m)	○	○	○	○
	R16 (16m) ~R20 (20m)	○	○	○	○

* Please refer to P.267 and 283 for more information regarding the maintenance cables.

Actuator Specifications

Item	Description
Drive system	Ball screw φ10mm, rolled C10
Positioning repeatability	±0.01mm
Lost motion	0.1mm or less
Rod	φ25mm Material: Aluminum with hard alumite treatment
Static allowable torque on rod tip	1.5N·m
Max. angular displacement on rod tip (*1)	±1.0 deg.
Ambient operating temp. & humidity	0~40°C, 85% RH or less (Non-condensing)

(*1) This is the displacement angle of the rod tip (initial reference value) when the rod is fully retracted and the static allowable torque is applied at the rod tip.

RCP6(S)-RA7R

Battery-less Absolute Motor Unit Type Side-mounted Motor Body Width 70* mm 24v Stepper Motor

Model Specification Items	Series	Type	Encoder Type	Motor Type	Lead	Stroke	Applicable Controller/I/O Type	Cable Length	Options
	RA7R	WA	56P						
	RCP6: Separate Controller RCP6S: Built-in Controller	WA: Battery-less Absolute	56P: Stepper Motor 56□ Size	24: 24mm 16: 16mm 8: 8mm 4: 4mm	50: 50mm 300: 300mm (50mm increments)	[RCP6] P3: PCON MCON MSEL P5: RCM-P6PC [RCP6S] SE: SIO Type	N: None P: 1m S: 3m M: 5m X□□ : Specified Length R□□ : Robot Cable	Please refer to the options table below. *Please make sure to specify ML, MR or MT when ordering the side-mounted motor type.	

* RCP6 does not include a controller. RCP6S includes a built-in controller.
* Please refer to P.16 for more information about the model specification items.

* Body width does not include the width of the side-mounted motor.

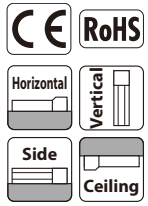

*Some limitations may apply to horizontal/side/ceiling mountings depending on the model. See page 204. Please contact IAI for more information.

The figure above is the motor side-mounted to the left (ML).

- POINT Selection Notes**
- The maximum acceleration/deceleration is 1G for horizontal, and 0.5G for vertical use.
 - The actuator specification displays the payload's maximum value, but it will vary depending on the acceleration and speed. Please refer to the "Selection Guidelines" (Tables of Payload by Speed/Acceleration) on P.225 for more details.
 - The value of the horizontal payload assumes that there is an external guide. Please be aware that the anti-rotation stopper can be damaged when an external force is applied to the rod from any direction other than the moving direction.
 - Please refer to P205 for performing push-motion operation.
 - Depending on the ambient operational temperature, duty control is necessary for the RCP6S (built-in controller type) with lead 4/8/16. Please refer to P.247 for more information.

Correlation Diagrams of Speed and Payload

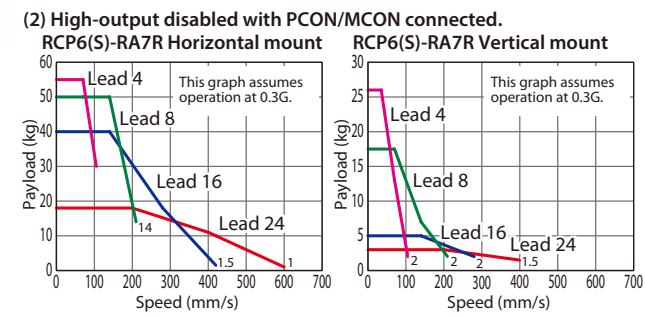
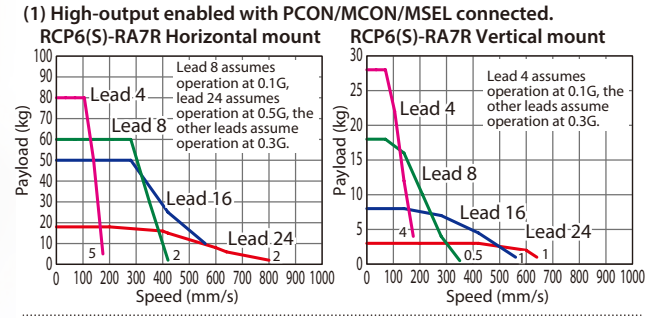

Actuator Specifications

Model Number	Lead (mm)	Connected Controller	Max. Payload		Max. Push Force (N)*	Stroke (mm)	Stroke and Max. Speed (Unit: mm/s)		
			Horizontal (kg)	Vertical (kg)			Lead (mm)	Connected Controller	50~300 (Every 50mm)
RCP6(S)-RA7R-WA-56P-24-①-②-③-④	24	High-output Enabled	20	3	182	50~300 (The increment of stroke is 50mm)	24	High-output Enabled	800 <640>
		High-output Disabled	18	3				High-output Disabled	600 <400>
RCP6(S)-RA7R-WA-56P-16-①-②-③-④	16	High-output Enabled	50	8	273	50~300 (The increment of stroke is 50mm)	16	High-output Enabled	560
		High-output Disabled	40	5				High-output Disabled	420 <280>
RCP6(S)-RA7R-WA-56P-8-①-②-③-④	8	High-output Enabled	60	18	547	50~300 (The increment of stroke is 50mm)	8	High-output Enabled	420 <350>
		High-output Disabled	50	17.5				High-output Disabled	210
RCP6(S)-RA7R-WA-56P-4-①-②-③-④	4	High-output Enabled	80	28	1,094	50~300 (The increment of stroke is 50mm)	4	High-output Enabled	175
		High-output Disabled	55	26				High-output Disabled	105

Legend: ① Stroke ② Applicable controller/I/O type ③ Cable length ④ Options

* Push force only available during push mode w / limited speed. Values in brackets < > are for vertical use.

① Stroke

Stroke (mm)	RCP6	RCP6S	Stroke (mm)	RCP6	RCP6S
50	○	○	200	○	○
100	○	○	250	○	○
150	○	○	300	○	○

④ Options

Name	Option Code	Reference Page
Brake	B	See P.189
Cable exit direction (Outside)	CJO	See P.189
Flange	FL	See P.190
Foot bracket	FT	See P.191
Motor side-mounted to the left	ML	See P.193
Motor side-mounted to the right	MR	See P.193
Motor side-mounted to the top	MT	See P.193
Tip adapter (Internal thread)	NFA	See P.193
Non-motor end specification	NM	See P.194
T-slot nut bar	NTB	See P.194

* Be sure to confirm with the "Selection Notes (P.196)" when selecting options.
When selecting multiple options, please list them in alphabetical order. (e.g. B-CJB-NM)

③ Cable Length

Cable Type	Cable Code	RCP6			RCP6S
		P3	P5	SE	
Standard	P (1m)	○	○	○	○
	S (3m)	○	○	○	○
	M (5m)	○	○	○	○
Specified Length	X06 (6m) ~X10 (10m)	○	○	○	○
	X11 (11m) ~X15 (15m)	○	○	○	○
	X16 (16m) ~X20 (20m)	○	○	○	○
	R01 (1m) ~R03 (3m)	○	○	○	○
Robot Cable	R04 (4m) ~R05 (5m)	○	○	○	○
	R06 (6m) ~R10 (10m)	○	○	○	○
	R11 (11m) ~R15 (15m)	○	○	○	○
	R16 (16m) ~R20 (20m)	○	○	○	○
	R16 (16m) ~R20 (20m)	○	○	○	○

* Please refer to P.267 and 283 for more information regarding the maintenance cables.

Actuator Specifications

Item	Description
Drive system	Ball screw φ12mm, rolled C10
Positioning repeatability	±0.01mm
Lost motion	0.1mm or less
Rod	φ30mm Material: Aluminum with hard alumite treatment
Static allowable torque on rod tip	2.5N·m
Max. angular displacement on rod tip (*1)	±0.8 deg.
Ambient operating temp. & humidity	0~40°C, 85% RH or less (Non-condensing)

(*1) This is the displacement angle of the rod tip (initial reference value) when the rod is fully retracted and the static allowable torque is applied at the rod tip.



*1 When the rod is returning to its home position, please be careful of interference from surrounding objects, as it will travel until it reaches the M.E.
M.E: Mechanical end S.E: Stroke end

*2 The direction of width across flats varies depending on the product.
Grease nipple (φ5 hole)
(Top and side)

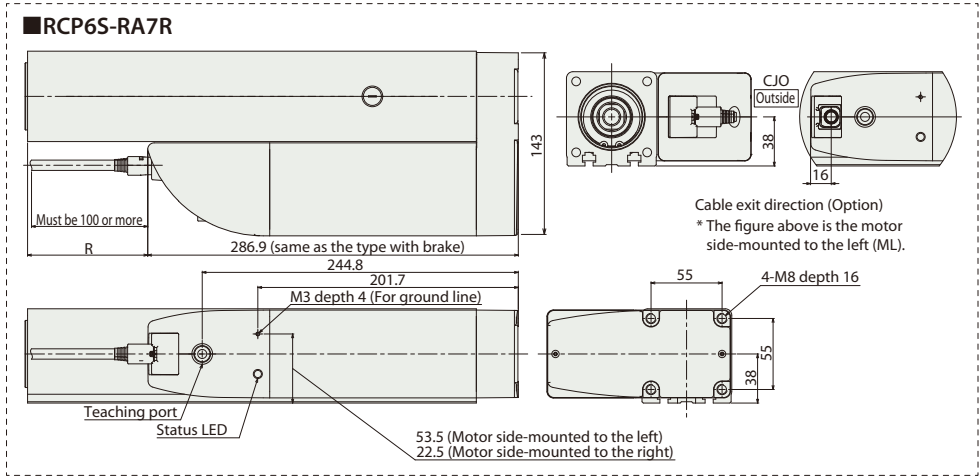
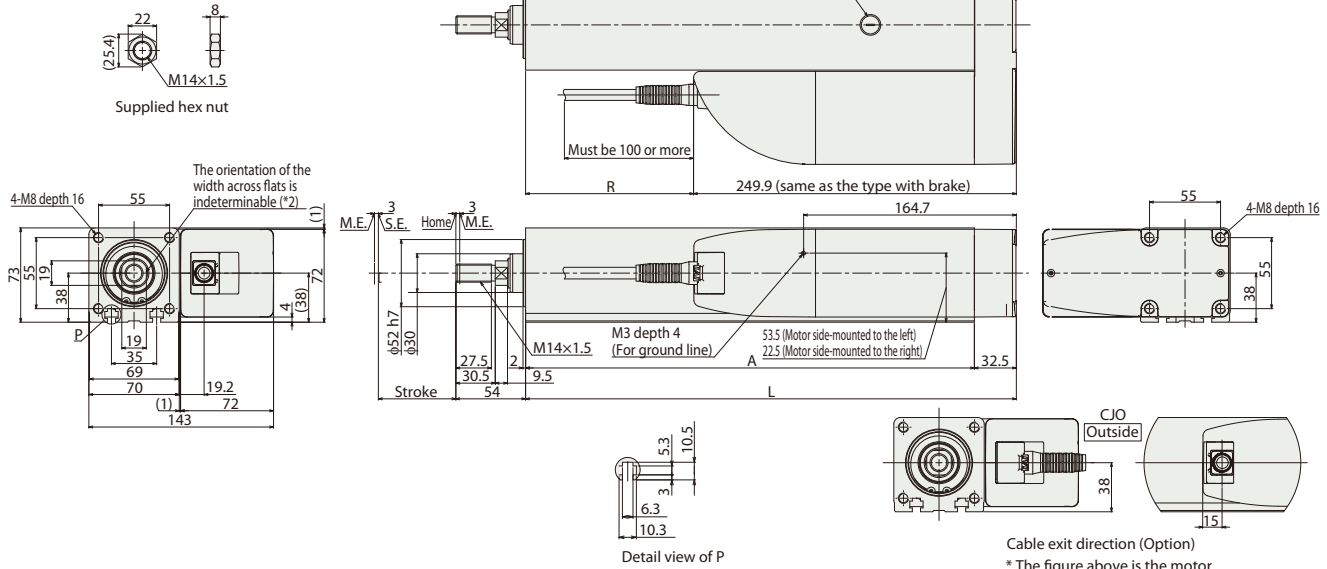

Note:
* If the length for R is negative in the table below, the length of the actuator body is shorter than the motor unit.

■ Dimensions and Mass by Stroke

Stroke	50	100	150	200	250	300		
L	230	280	330	380	430	480		
A	197.5	247.5	297.5	347.5	397.5	447.5		
R	RCP6	-19.9	30.1	80.1	130.1	180.1	230.1	
	RCP6S	-56.9	-6.9	43.1	93.1	143.1	193.1	
Mass (kg)	RCP6	w/o brake	5.1	5.7	6.3	6.9	7.5	8.1
	RCP6S	w/o brake	5.2	5.8	6.4	7.0	7.6	8.2
	RCP6	w/ brake	5.1	5.7	6.3	6.9	7.5	8.1
	RCP6S	w/ brake	5.2	5.8	6.4	7.0	7.6	8.2

② Applicable Controllers

The RCP6 series actuators can be operated by the controllers indicated below. Please select the type depending on your intended use. * Please refer to P.271 for more information about the built-in controller of RCP6S series.

Name	External view	Max. number of controlled axes	Input power	Control method				Maximum number of positioning points	Reference page
				Positioner	Pulse train	Program	Network * Option		
PCON-CYB/PLB/POB		1	DC24V	●	●	-	Network cannot be selected	64	Please contact IAI for more information.
PCON-CB/CGB		1		* Option	* Option	-	Network cannot be selected	512	Please see P.255
MCON-C/CG		8		●	●	-	Network cannot be selected	256	Please contact IAI for more information.
MCON-LC/LCG		6		-	-	●	Network cannot be selected	256	Please contact IAI for more information.
MSEL-PC/PG		4	Single-phase 100 ~ 230 VAC	-	-	●	Network cannot be selected	30,000	Please contact IAI for more information.
RCM-P6PC		1		Usable within the RCP6S Gateway system.				768	Please see P.279

* For the MCON controller, high-output enabled operation is only available if "high-output setting" is selected as an option. The maximum connectable axes with high-output enabled are C: 4 and LC: 3.

Foreword
Slider Type
Wide Slider Type
Rod Type
Radial Cylinder
Wide Radial Cylinder
Table Type
Cleanroom Slider
Cleanroom Wide Slider
Dust/Splash-Proof Rod
Dust/Splash-Proof Radial Cylinder
Dust/Splash-Proof Wide Radial Cylinder
Options
Reference Data
Controller

RCP6(S)-RA8R

Battery-less Absolute Motor Unit Type Side-mounted Motor Body Width 85* mm 24v Stepper Motor

Model Specification Items	Series	Type	Encoder Type	Motor Type	Lead	Stroke	Applicable Controller/I/O Type	Cable Length	Options
	RA8R	WA	60P						
	RCP6: Separate Controller RCP6S: Built-in Controller	WA: Battery-less Absolute	60P: Stepper Motor 60□ Size	20: 20mm 10: 10mm 5: 5mm	50: 50mm 300: 300mm (50mm increments)	[RCP6] P4: PCON- CFB/CGFB [RCP6S] SE: SIO Type	N : None P : 1m S : 3m M : 5m X□□ : Specified Length R□□ : Robot Cable	Please refer to the options table below. *Please make sure to specify ML, MR or MT when ordering the side-mounted motor type.	

* Body width does not include the width of the side-mounted motor.

* RCP6 does not include a controller. RCP6S includes a built-in controller.
* Please refer to P.16 for more information about the model specification items.

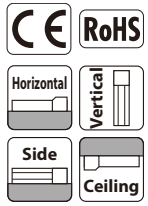

The figure above is the motor side-mounted to the left (ML).

*Some limitations may apply to horizontal/side/ceiling mountings depending on the model. See page 204. Please contact IAI for more information.

- POINT Selection Notes**
- (1) The maximum acceleration/deceleration is 0.1G for lead 5 and 0.2G for lead 10/20.
 - (2) The actuator specification displays the payload's maximum value, but it will vary depending on the acceleration and speed. Please refer to the "Selection Guidelines" (Tables of Payload by Speed/Acceleration) on P.225 for more details.
 - (3) The value of the horizontal payload assumes that there is an external guide. Please be aware that the anti-rotation stopper can be damaged when an external force is applied to the rod from any direction other than the moving direction.
 - (4) Please refer to P205 for performing push-motion operation.
 - (5) For RCP6S (built-in controller type), please limit the duty cycle to 70% or less.
 - (6) The service life of an actuator varies depending on the payload when using vertically. Please refer to P. 206 for more information.

Correlation Diagrams of Speed and Payload PCON connected.

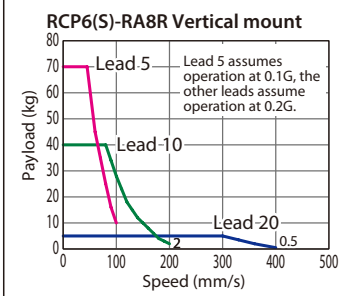
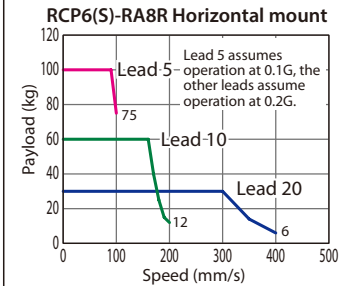

Actuator Specifications

Model Number	Lead (mm)	Max. Payload		Max. Push Force (N)*	Stroke (mm)	Stroke and Max. Speed	
		Horizontal (kg)	Vertical (kg)			Lead (mm)	50~300 (Every 50mm)
RCP6(S)-RA8R-WA-60P-20-①-②-③-④	20	30	5	500	50~300 (The increment of stroke is 50mm)	20	400
RCP6(S)-RA8R-WA-60P-10-①-②-③-④	10	60	40	1,000		10	200
RCP6(S)-RA8R-WA-60P-5-①-②-③-④	5	100	70	2,000		5	100

Legend: ① Stroke ② Applicable controller/I/O type ③ Cable length ④ Options

① Stroke

Stroke (mm)	RCP6	RCP6S	Stroke (mm)	RCP6	RCP6S
50	○	○	200	○	○
100	○	○	250	○	○
150	○	○	300	○	○

④ Options

Name	Option Code	Reference Page
Brake	B	See P.189
Cable exit direction (Outside)	CJO	See P.189
Flange	FL	See P.190
Foot bracket	FT	See P.191
Motor side-mounted to the left	ML	See P.193
Motor side-mounted to the right	MR	See P.193
Motor side-mounted to the top	MT	See P.193
Tip adapter (Internal thread)	NFA	See P.193
Non-motor end specification	NM	See P.194
T-slot nut bar	NTB	See P.194

* Be sure to confirm with the "Selection Notes (P.196)" when selecting options.
When selecting multiple options, please list them in alphabetical order. (e.g. B-CJB-NM)

③ Cable Length

Cable Type	Cable Code	RCP6	RCP6S
Standard	P (1m)	○	○
	S (3m)	○	○
	M (5m)	○	○
Specified Length	X06 (6m) ~X10 (10m)	○	○
	X11 (11m) ~X15 (15m)	○	○
	X16 (16m) ~X20 (20m)	○	○
	R01 (1m) ~R03 (3m)	○	○
Robot Cable	R04 (4m) ~R05 (5m)	○	○
	R06 (6m) ~R10 (10m)	○	○
	R11 (11m) ~R15 (15m)	○	○
	R16 (16m) ~R20 (20m)	○	○

* Please refer to P.267 and 283 for more information regarding the maintenance cables.

Actuator Specifications

Item	Description
Drive system	Ball screw φ16mm, rolled C10
Positioning repeatability	±0.01mm
Lost motion	0.1mm or less
Rod	φ40mm Material: Aluminum with hard alumite treatment
Static allowable torque on rod tip	5N·m
Max. angular displacement on rod tip (*1)	±0.8 deg.
Ambient operating temp. & humidity	0~40°C, 85% RH or less (Non-condensing)

(*1) This is the displacement angle of the rod tip (initial reference value) when the rod is fully retracted and the static allowable torque is applied at the rod tip.

CAD drawings can be downloaded from our website.
www.intelligentactuator.com



*1 When the rod is returning to its home position, please be careful of interference from surrounding objects, as it will travel until it reaches the M.E.
M.E: Mechanical end S.E: Stroke end

*2 The direction of width across flats varies depending on the product.

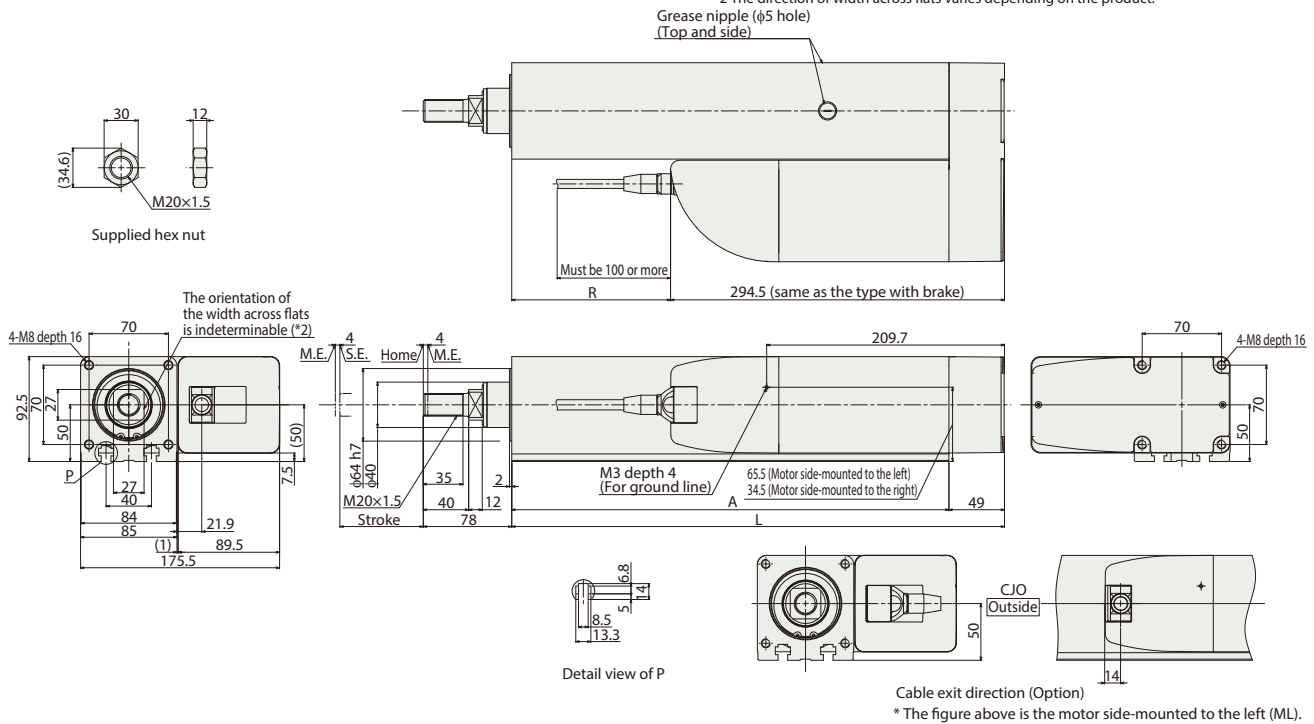

* The figure above is the motor side-mounted to the left (ML).

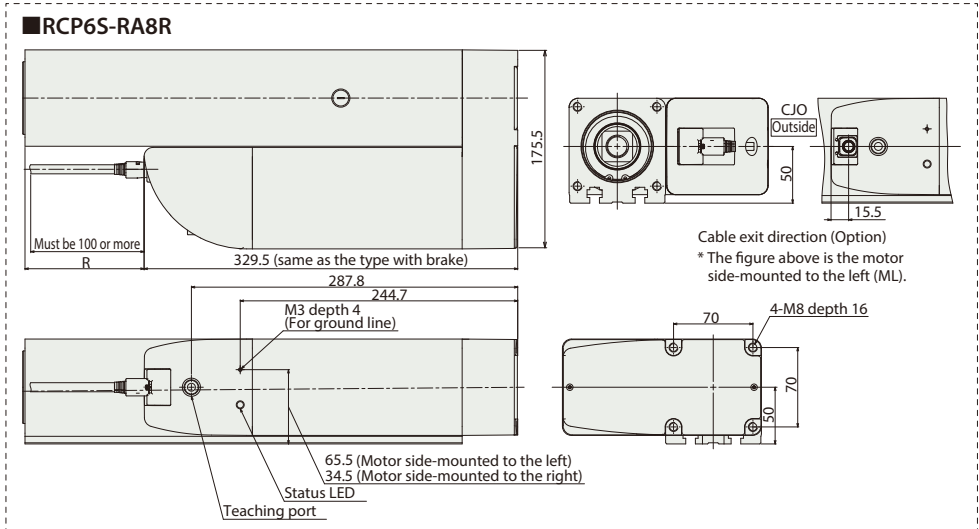

Note:
* If the length for R is negative in the table below, the length of the actuator body is shorter than the motor unit.

■ Dimensions and Mass by Stroke

Stroke	50	100	150	200	250	300	
L	284.5	334.5	384.5	434.5	484.5	534.5	
A	235.5	285.5	335.5	385.5	435.5	485.5	
R	RCP6	-10	40	90	140	190	
	RCP6S	-45	5	55	105	155	
Mass (kg)	RCP6	w/o brake	9.0	9.9	10.8	11.7	12.6
		w/ brake	9.2	10.1	11.0	11.9	12.8
	RCP6S	w/o brake	9.2	10.1	11.0	11.9	12.8
		w/ brake	9.4	10.3	11.2	12.1	13.0

② Applicable Controllers

The RCP6 series actuators can be operated by the controllers indicated below. Please select the type depending on your intended use.* Please refer to P.271 for more information about the built-in controller of RCP6S series.

Name	External view	Max. number of controlled axes	Input power	Control method			Maximum number of positioning points	Reference page
				Positioner	Pulse train	Program		
PCON-CFB/CGFB		1	DC24V	●	●	-	512 (768 for network spec.)	Please see P.255
				*Option	*Option			
Control method Network * Option DeviceNet CompoNet EtherNet/IP CC-Link MECHATROLINK EtherCAT								

RCP6(S)-RRA4C

Battery-less Absolute Motor Unit Type Coupled Motor Body Width 40 mm 24v Stepper Motor

Model Specification Items

Series	Type	Encoder Type	Motor Type	Lead	Stroke	Applicable Controller/I/O Type	Cable Length	Options
RCP6: Separate Controller RCP6S: Built-in Controller	RRA4C	WA : Battery-less Absolute	35P : Stepper Motor 35□ Size	16: 16mm 10: 10mm 5: 5mm 2.5: 2.5mm	60: 60mm 410: 410mm (50mm increments)	[RCP6] P3: PCON MCON MSEL P5: RCM-P6PC [RCP6S] SE: SIO Type	N: None P: 1m S: 3m M: 5m X□: Specified Length R□: Robot Cable	Please refer to the options table below.

* RCP6 does not include a controller. RCP6S includes a built-in controller.
* Please refer to P.16 for more information about the model specification items.

Radial Load OK

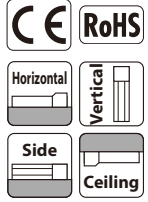

*Some limitations may apply to horizontal/side/ceiling mountings depending on the model. See page 204. Please contact IAI for more information.

- POINT Selection Notes**
- (1) The maximum acceleration/deceleration is 1G for horizontal, and 0.5G for vertical use.
 - (2) The actuator specification displays the payload's maximum value, but it will vary depending on the acceleration and speed. Please refer to the "Selection Guidelines" (Tables of Payload by Speed/Acceleration) on P.215 for more details.
 - (3) The radial cylinder is equipped with a built-in guide. Please refer to the graphs shown in P.243 and after for the allowable load mass.
 - (4) Please refer to P.205 for performing push-motion operation.

Correlation Diagrams of Speed and Payload

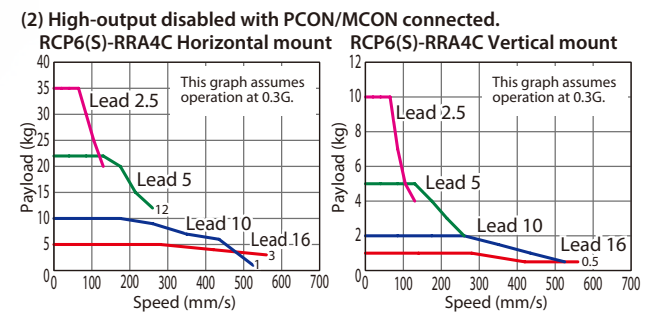
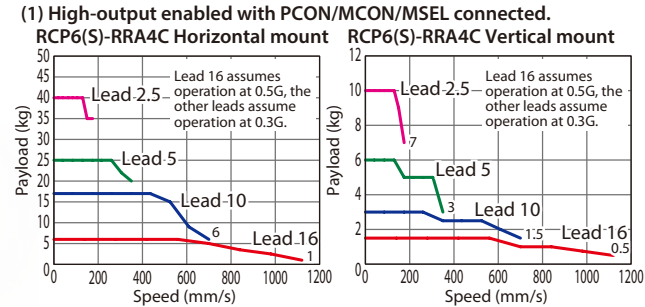

Actuator Specifications

* Horizontal external guide rail required for horizontal payload.
** Push force only available during push mode w / limited speed.

Model Number	Lead (mm)	Connected Controller	Max. Payload		Max. Push Force (N)**	Stroke (mm)	Stroke and Max. Speed (Unit: mm/s)			
			Horizontal (kg)*	Vertical (kg)			Lead (mm)	Connected Controller	60~360 (Every 50mm)	410 (mm)
RCP6(S)-RRA4C-WA-35P-16-①-②-③-④	16	High-output Enabled	7	1.5	48	60~410 (The increment of stroke is 50mm)	16	High-output Enabled	1,120	1,080
		High-output Disabled	5	1				High-output Disabled	560	
RCP6(S)-RRA4C-WA-35P-10-①-②-③-④	10	High-output Enabled	18	3	77		10	High-output Enabled	700	685
		High-output Disabled	10	2				High-output Disabled	525	
RCP6(S)-RRA4C-WA-35P-5-①-②-③-④	5	High-output Enabled	28	6	155		5	High-output Enabled	350	340
		High-output Disabled	22	5				High-output Disabled	260	
RCP6(S)-RRA4C-WA-35P-2.5-①-②-③-④	2.5	High-output Enabled	40	10	310		2.5	High-output Enabled	175	170
		High-output Disabled	35	10				High-output Disabled	130	

Legend: ① Stroke ② Applicable controller/I/O type ③ Cable length ④ Options

① Stroke

Stroke (mm)	RCP6	RCP6S	Stroke (mm)	RCP6	RCP6S
60	○	○	260	○	○
110	○	○	310	○	○
160	○	○	360	○	○
210	○	○	410	○	○

④ Options

Name	Option Code	Reference Page
Brake	B	See P.189
Cable exit direction (Top)	CJT	See P.189
Cable exit direction (Right)	CJR	See P.189
Cable exit direction (Left)	CJL	See P.189
Cable exit direction (Bottom)	CJB	See P.189
Flange	FL	See P.190
Tip adapter (Flange)	FFA	See P.189
Tip adapter (Internal thread)	NFA	See P.192
Tip adapter (Keyway)	KFA	See P.193
Non-motor end specification	NM	See P.194

When selecting multiple options, please list them in alphabetical order. (e.g. B-CJB-NM)

③ Cable Length

Cable Type	Cable Code	RCP6		RCP6S
		P3	P5	SE
Standard	P (1m)	○	○	○
	S (3m)	○	○	○
	M (5m)	○	○	○
Specified Length	X06 (6m) ~ X10 (10m)	○	○	○
	X11 (11m) ~ X15 (15m)	○	○	○
	X16 (16m) ~ X20 (20m)	○	○	○
	R01 (1m) ~ R03 (3m)	○	○	○
Robot Cable	R04 (4m) ~ R05 (5m)	○	○	○
	R06 (6m) ~ R10 (10m)	○	○	○
	R11 (11m) ~ R15 (15m)	○	○	○
	R16 (16m) ~ R20 (20m)	○	○	○
		○	○	○

* Please refer to P.267 and 283 for more information regarding the maintenance cables.

Actuator Specifications

Item	Description
Drive system	Ball screw φ8mm, rolled C10
Positioning repeatability	±0.01mm
Lost motion	0.1mm or less
Rod	φ20mm Aluminum
Rod non-rotation precision*	0 deg.
Allowable load and torque on rod tip	See P.243
Rod tip overhang distance	100mm or less
Ambient operating temp. & humidity	0~40°C, 85% RH or less (Non-condensing)

* Rod's angular displacement in rotational direction with no load applied to the rod.

RCP6(S)-RRA6C

Battery-less Absolute

Motor Unit Type

Coupled Motor

Body Width 58 mm

24v Stepper Motor

Model Specification Items

Series	Type	Encoder Type	Motor Type	Lead	Stroke	Applicable Controller/I/O Type	Cable Length	Options
RCP6: Separate Controller RCP6S: Built-in Controller	RRA6C	WA: Battery-less Absolute	42P: Stepper Motor 42□ Size	20: 20mm 12: 12mm 6: 6mm 3: 3mm	65: 65mm 415: 415mm (50mm increments)	[RCP6] P3: PCON/MCON/MSEL P5: RCM-P6PC [RCP6S] SE: SIO Type	N: None P: 1m S: 3m M: 5m X□□: Specified Length R□□: Robot Cable	Please refer to the options table below.

* RCP6 does not include a controller. RCP6S includes a built-in controller.
* Please refer to P.16 for more information about the model specification items.

Radial Load OK

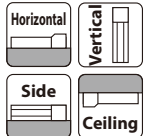

*Some limitations may apply to horizontal/side/ceiling mountings depending on the model. See page 204. Please contact IAI for more information.



- POINT Selection Notes**
- (1) The maximum acceleration/deceleration is 1G for horizontal, and 0.5G for vertical use.
 - (2) The actuator specification displays the payload's maximum value, but it will vary depending on the acceleration and speed. Please refer to the "Selection Guidelines" (Tables of Payload by Speed/Acceleration) on P.215 for more details.
 - (3) The radial cylinder is equipped with a built-in guide. Please refer to the graphs shown in P.243 and after for the allowable load mass.
 - (4) Please refer to P.205 for performing push-motion operation.
 - (5) Depending on the ambient operational temperature, duty control is necessary for the RCP6S (built-in controller type) with lead 3/6. Please refer to P.247 for more information.

Correlation Diagrams of Speed and Payload

(1) High-output enabled with PCON/MCON/MSEL connected.

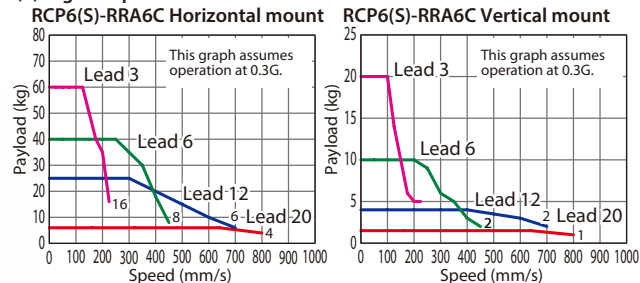

(2) High-output disabled with PCON/MCON connected.

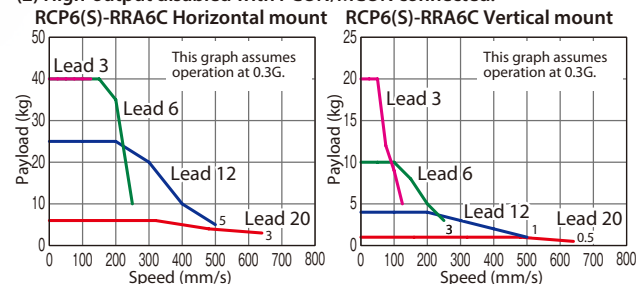

Actuator Specifications

Lead and Payload

Model Number	Lead (mm)	Connected Controller	Max. Payload		Max. Push Force (N)**	Stroke (mm)
			Horizontal (kg)*	Vertical (kg)		
RCP6(S)-RRA6C-WA-42P-20-①-②-③-④	20	High-output Enabled	6	1.5	56	65~415 (The increment of stroke is 50mm)
		High-output Disabled	6	1		
RCP6(S)-RRA6C-WA-42P-12-①-②-③-④	12	High-output Enabled	25	4	93	
		High-output Disabled	25	4		
RCP6(S)-RRA6C-WA-42P-6-①-②-③-④	6	High-output Enabled	40	10	185	
		High-output Disabled	40	10		
RCP6(S)-RRA6C-WA-42P-3-①-②-③-④	3	High-output Enabled	60	20	370	
		High-output Disabled	40	20		

Legend: ① Stroke ② Applicable controller/I/O type ③ Cable length ④ Options

Stroke and Max. Speed

Lead (mm)	Connected Controller	65~365 (Every 50mm)		415 (mm)
		Stroke (mm)	Max. Speed (mm/s)	
20	High-output Enabled	800		
	High-output Disabled	640		
12	High-output Enabled	700		
	High-output Disabled	500		
6	High-output Enabled	450		
	High-output Disabled	250		
3	High-output Enabled	225	220	
	High-output Disabled	125		

① Stroke

Stroke (mm)	RCP6	RCP6S	Stroke (mm)	RCP6	RCP6S
65	○	○	265	○	○
115	○	○	315	○	○
165	○	○	365	○	○
215	○	○	415	○	○

④ Options

Name	Option Code	Reference Page
Brake	B	See P.189
Cable exit direction (Top)	CJT	See P.189
Cable exit direction (Right)	CJR	See P.189
Cable exit direction (Left)	CJL	See P.189
Cable exit direction (Bottom)	CJB	See P.189
Flange	FL	See P.190
Tip adapter (Flange)	FFA	See P.189
Tip adapter (Internal thread)	NFA	See P.192
Tip adapter (Keyway)	KFA	See P.193
Non-motor end specification	NM	See P.194

When selecting multiple options, please list them in alphabetical order. (e.g. B-CJB-NM)

③ Cable Length

Cable Type	Cable Code	RCP6			RCP6S
		P3	P5	SE	
Standard	P (1m)	○	○	○	○
	S (3m)	○	○	○	○
	M (5m)	○	○	○	○
Specified Length	X06 (6m) ~X10 (10m)	○	○	○	○
	X11 (11m) ~X15 (15m)	○	○	○	○
	X16 (16m) ~X20 (20m)	○	○	○	○
	R01 (1m) ~R03 (3m)	○	○	○	○
Robot Cable	R04 (4m) ~R05 (5m)	○	○	○	○
	R06 (6m) ~R10 (10m)	○	○	○	○
	R11 (11m) ~R15 (15m)	○	○	○	○
	R16 (16m) ~R20 (20m)	○	○	○	○
		○	○	○	○

* Please refer to P.267 and 283 for more information regarding the maintenance cables.

Actuator Specifications

Item	Description
Drive system	Ball screw φ10mm, rolled C10
Positioning repeatability	±0.01mm
Lost motion	0.1mm or less
Rod	φ25mm Aluminum
Rod non-rotation precision*	0 deg.
Allowable load and torque on rod tip	See P. 243
Rod tip overhang distance	100mm or less
Ambient operating temp. & humidity	0~40°C, 85% RH or less (Non-condensing)

* Rod's angular displacement in rotational direction with no load applied to the rod.

CAD drawings can be downloaded from our website.
www.intelligentactuator.com



- *1 When the rod is returning to its home position, please be careful of interference from surrounding objects, as it will travel until it reaches the M.E. M.E: Mechanical end S.E: Stroke end
- *2 The direction of width across flats varies depending on the product.
- *3 When fixing the actuator using a front bracket or flange, please make sure that there is no external force applied to the main body.

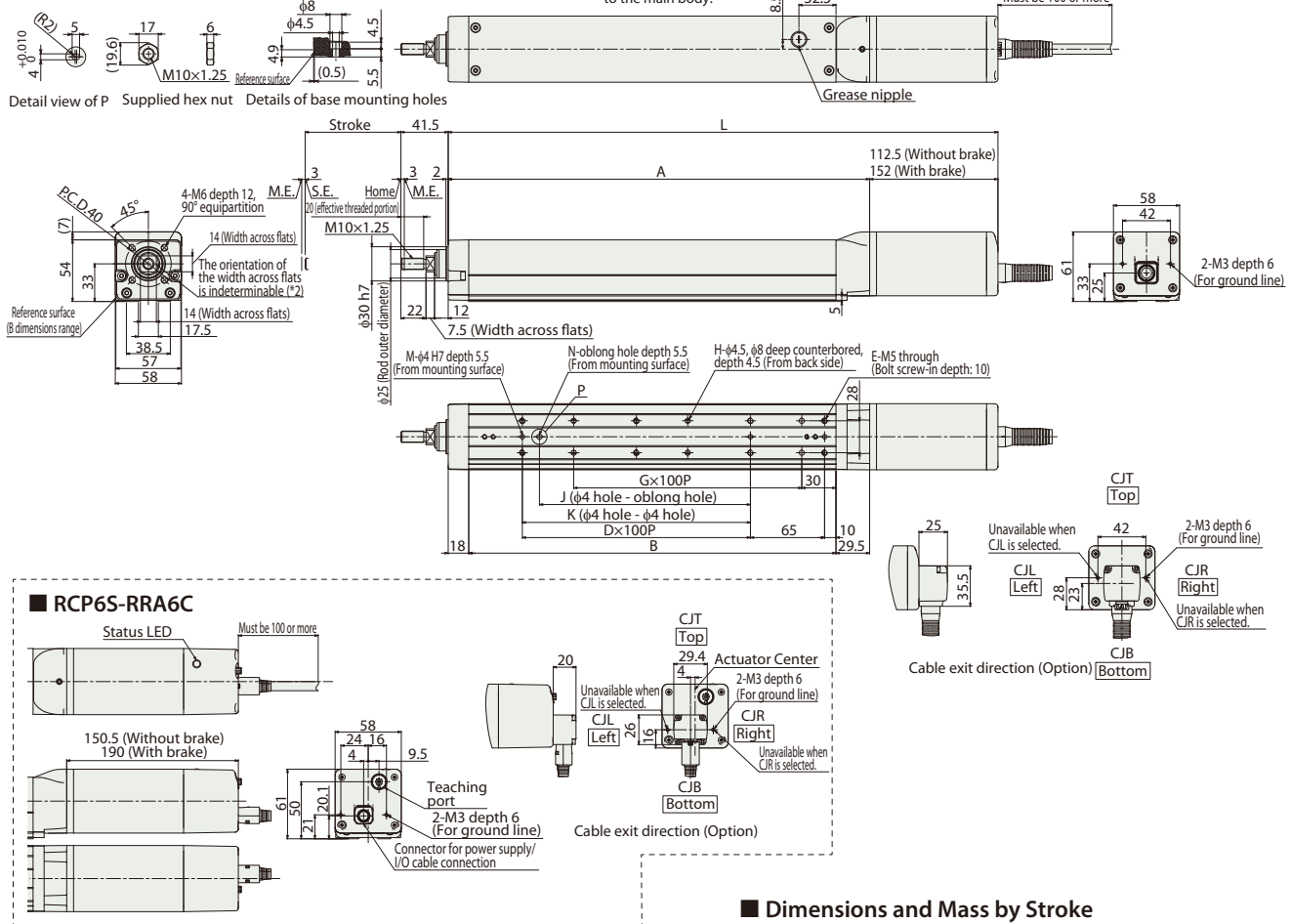

■ Dimensions and Mass by Stroke

		Stroke	65	115	165	215	265	315	365	415
L	RCP6	w/o brake	332	382	432	482	532	582	632	682
		w/ brake	371.5	421.5	471.5	521.5	571.5	621.5	671.5	721.5
	RCP6S	w/o brake	370	420	470	520	570	620	670	720
		w/ brake	409.5	459.5	509.5	559.5	609.5	659.5	709.5	759.5
A			219.5	269.5	319.5	369.5	419.5	469.5	519.5	569.5
B			172	222	272	322	372	422	472	522
D			0	1	1	2	2	3	3	4
E			4	6	6	8	8	10	10	12
G			1	1	2	2	3	3	4	4
H			4	4	6	6	8	8	10	10
J			0	85	85	185	185	285	285	385
K			0	100	100	200	200	300	300	400
M			2	3	3	3	3	3	3	3
N			0	1	1	1	1	1	1	1
Allowable static load on rod tip (N)			144	117	99	85.4	75	66.7	59.9	54.3
Allowable dynamic load on rod tip (5000km life) (N)			58.1	46.4	38.3	32.4	27.9	24.4	21.5	19.2
Allowable static torque on rod tip (N·m)			14.5	11.8	10.0	8.7	7.6	6.8	6.2	5.6
Allowable dynamic torque on rod tip (N·m)			3.8	3.3	2.9	2.6	2.3	2.0	1.8	1.6
Mass (kg)	RCP6	w/o brake	2.1	2.3	2.6	2.8	3.0	3.2	3.5	3.7
		w/ brake	2.4	2.6	2.8	3.0	3.3	3.5	3.7	3.9
	RCP6S	w/o brake	2.3	2.5	2.7	2.9	3.2	3.4	3.6	3.8
		w/ brake	2.5	2.7	3.0	3.2	3.4	3.6	3.8	4.1

■ Rod Deflection of RCP6(S)-RRA6C (Reference Values)

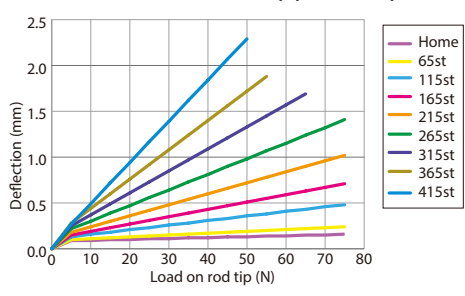

② Applicable Controllers

The RCP6 series actuators can be operated by the controllers indicated below. Please select the type depending on your intended use. * Please refer to P.271 for more information about the built-in controller of RCP6S series.

Name	External view	Max. number of controlled axes	Input power	Control method				Maximum number of positioning points	Reference page
				Positioner	Pulse train	Program	Network * Option		
PCON-CYB/PLB/POB		1	DC24V	●	●	—	Network cannot be selected	64	Please contact IAI for more information.
PCON-CB/CGB		1		* Option	* Option	—	DeviceNet MECHATROLINK CC-Link EtherCAT EtherNet/IP PROFINET CompoNet	512 (768 for network spec.)	Please see P.255
MCON-C/CG		8		This model is network-compatible only.				Note: The type of compatible networks will vary depending on the controller. Please refer to reference page for more information.	256
MCON-LC/LCG		6		—	—	●	256		Please contact IAI for more information.
MSEL-PC/PG		4	Single-phase 100 ~ 230 VAC	—	—	●	30,000	Please contact IAI for more information.	
RCM-P6PC		1		Usable within the RCP6S Gateway system.				768	Please see P.279

* For the MCON controller, high-output enabled operation is only available if "high-output setting" is selected as an option. The maximum connectable axes with high-output enabled are C: 4 and LC: 3.

RCP6(S)-RRA7C

Battery-less Absolute

Motor Unit Type

Coupled Motor

Body Width 70 mm

24v Stepper Motor

Model Specification Items

Series	Type	Encoder Type	Motor Type	Lead	Stroke	Applicable Controller/I/O Type	Cable Length	Options
RCP6: Separate Controller RCP6S: Built-in Controller	RRA7C	WA: Battery-less Absolute	56P: Stepper Motor 56□ Size	24: 24mm 16: 16mm 8: 8mm 4: 4mm	70: 70mm 520: 520mm (50mm increments)	[RCP6] P3: PCON/MCON/MSEL P5: RCM-P6PC [RCP6S] SE: SIO Type	N: None P: 1m S: 3m M: 5m X□□: Specified Length R□□: Robot Cable	Please refer to the options table below.

* RCP6 does not include a controller. RCP6S includes a built-in controller.
* Please refer to P.16 for more information about the model specification items.

Radial Load OK



*Some limitations may apply to horizontal/side/ceiling mountings depending on the model. See page 204. Please contact IAI for more information.

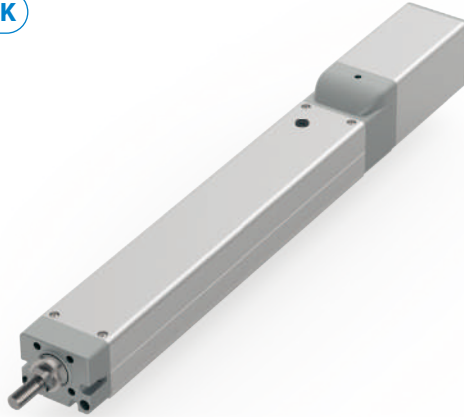

- POINT Selection Notes**
- (1) The maximum acceleration/deceleration is 1G for horizontal, and 0.5G for vertical use.
 - (2) The actuator specification displays the payload's maximum value, but it will vary depending on the acceleration and speed. Please refer to the "Selection Guidelines" (Tables of Payload by Speed/Acceleration) on P.215 for more details.
 - (3) The radial cylinder is equipped with a built-in guide. Please refer to the graphs shown in P.243 and after for the allowable load mass.
 - (4) Please refer to P205 for performing push-motion operation.
 - (5) Depending on the ambient operational temperature, duty control is necessary for the RCP6S (built-in controller type) with lead 4/8/16. Please refer to P.247 for more information.

Correlation Diagrams of Speed and Payload

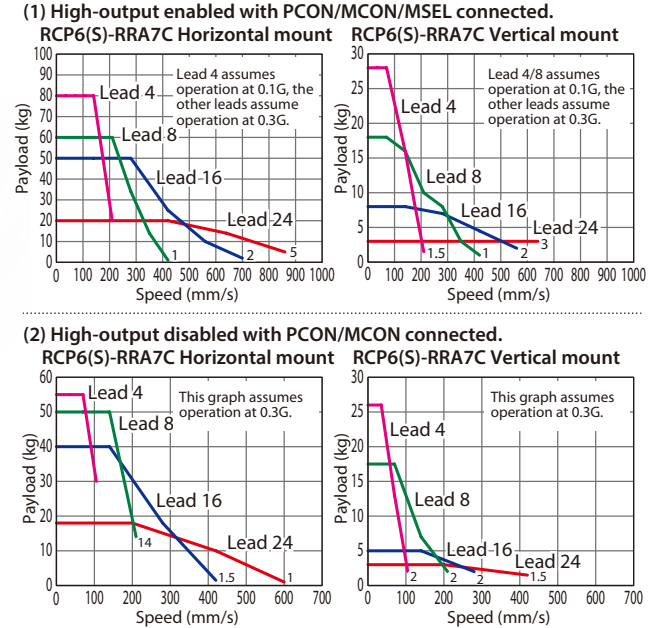

Actuator Specifications

Lead and Payload

Model Number	Lead (mm)	Connected Controller	Max. Payload		Max. Push Force (N)**	Stroke (mm)
			Horizontal (kg)*	Vertical (kg)		
RCP6(S)-RRA7C-WA-56P-24-①-②-③-④	24	High-output Enabled	20	3	182	70~520 (The increment of stroke is 50mm)
		High-output Disabled	18	3		
RCP6(S)-RRA7C-WA-56P-16-①-②-③-④	16	High-output Enabled	50	8	273	
		High-output Disabled	40	5		
RCP6(S)-RRA7C-WA-56P-8-①-②-③-④	8	High-output Enabled	60	18	547	
		High-output Disabled	50	17.5		
RCP6(S)-RRA7C-WA-56P-4-①-②-③-④	4	High-output Enabled	80	28	1,094	
		High-output Disabled	55	26		

Legend: ① Stroke ② Applicable controller/I/O type ③ Cable length ④ Options

Stroke and Max. Speed

Lead (mm)	Connected Controller	70~520 (Every 50mm)
24	High-output Enabled	860 <640>
	High-output Disabled	600 <420>
16	High-output Enabled	700 <560>
	High-output Disabled	420 <280>
8	High-output Enabled	420
	High-output Disabled	210
4	High-output Enabled	210
	High-output Disabled	105

Values in brackets < > are for vertical use.

① Stroke

Stroke (mm)	RCP6	RCP6S	Stroke (mm)	RCP6	RCP6S
70	○	○	320	○	○
120	○	○	370	○	○
170	○	○	420	○	○
220	○	○	470	○	○
270	○	○	520	○	○

④ Options

Name	Option Code	Reference Page
Brake	B	See P.189
Cable exit direction (Top)	CJT	See P.189
Cable exit direction (Right)	CJR	See P.189
Cable exit direction (Left)	CJL	See P.189
Cable exit direction (Bottom)	CJB	See P.189
Flange	FL	See P.190
Tip adapter (Flange)	FFA	See P.189
Tip adapter (Internal thread)	NFA	See P.192
Tip adapter (Keyway)	KFA	See P.193
Non-motor end specification	NM	See P.194

When selecting multiple options, please list them in alphabetical order. (e.g. B-CJB-NM)

③ Cable Length

Cable Type	Cable Code	RCP6			RCP6S
		P3	P5	SE	
Standard	P (1m)	○	○	○	○
	S (3m)	○	○	○	○
	M (5m)	○	○	○	○
Specified Length	X06 (6m) ~X10 (10m)	○	○	○	○
	X11 (11m) ~X15 (15m)	○	○	○	○
	X16 (16m) ~X20 (20m)	○	○	○	○
	R01 (1m) ~R03 (3m)	○	○	○	○
Robot Cable	R04 (4m) ~R05 (5m)	○	○	○	○
	R06 (6m) ~R10 (10m)	○	○	○	○
	R11 (11m) ~R15 (15m)	○	○	○	○
	R16 (16m) ~R20 (20m)	○	○	○	○
	R16 (16m) ~R20 (20m)	○	○	○	○

* Please refer to P.267 and 283 for more information regarding the maintenance cables.

Actuator Specifications

Item	Description
Drive system	Ball screw φ12mm, rolled C10
Positioning repeatability	±0.01mm
Lost motion	0.1mm or less
Rod	φ30mm Aluminum
Rod non-rotation precision*	0 deg.
Allowable load and torque on rod tip	See P.243
Rod tip overhang distance	150mm or less
Ambient operating temp. & humidity	0~40°C, 85% RH or less (Non-condensing)

* Rod's angular displacement in rotational direction with no load applied to the rod.

CAD drawings can be downloaded from our website.
www.intelligentactuator.com



- *1 When the rod is returning to its home position, please be careful of interference from surrounding objects, as it will travel until it reaches the M.E. M.E: Mechanical end S.E: Stroke end
- *2 The direction of width across flats varies depending on the product.
- *3 When fixing the actuator using a front bracket or flange, please make sure that there is no external force applied to the main body.

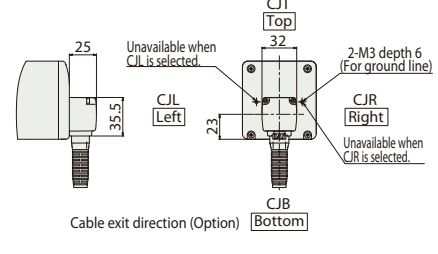
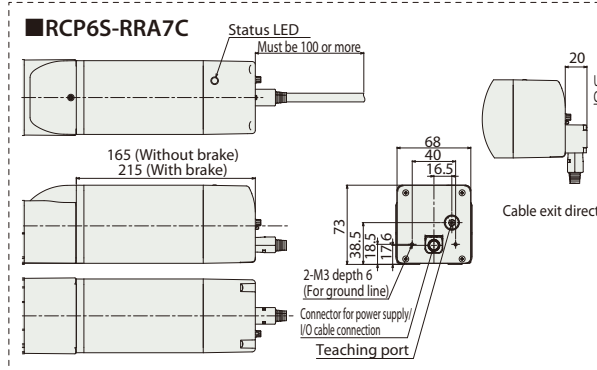
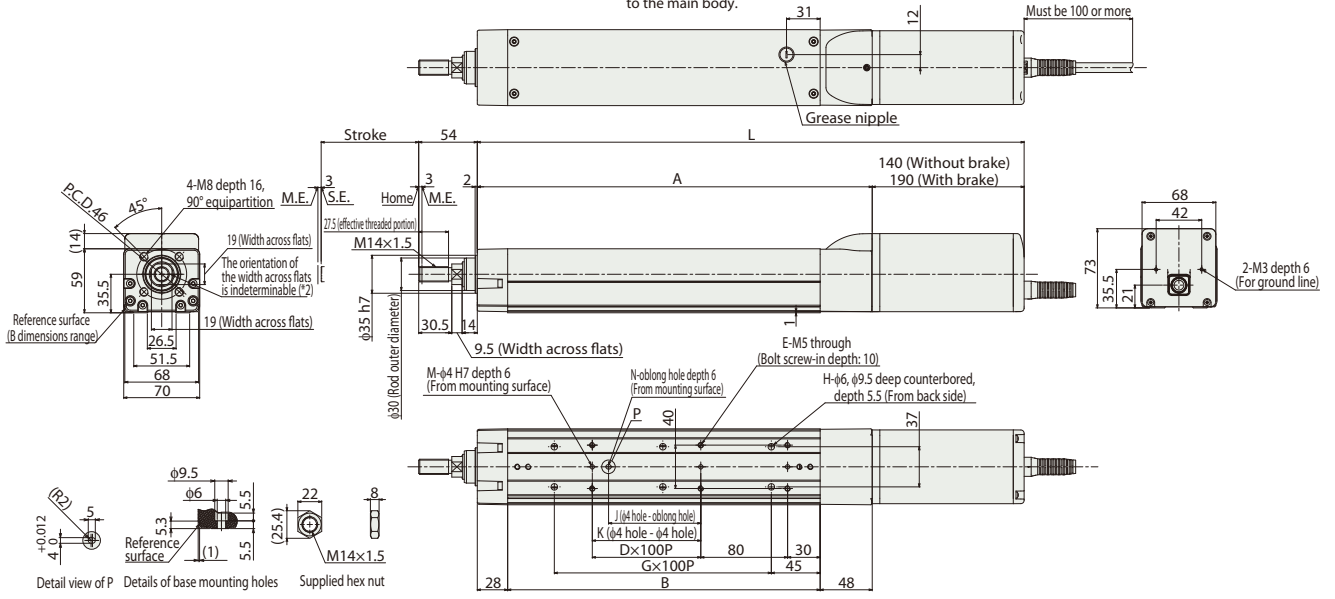

■ Rod Deflection of RCP6(S)-RRA7C (Reference Values)

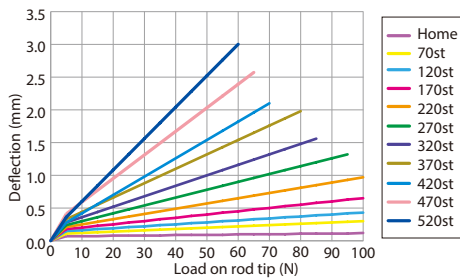

■ Dimensions and Mass by Stroke

L	Stroke	70	120	170	220	270	320	370	420	470	520
		RCP6 w/o brake	404	454	504	554	604	654	704	754	804
RCP6S w/o brake	429	479	529	579	629	679	729	779	829	879	
RCP6S w/ brake	479	529	579	629	679	729	779	829	879	929	
A		264	314	364	414	464	514	564	614	664	714
B		188	238	288	338	388	438	488	538	588	638
D		0	1	1	2	2	3	3	4	4	5
E		4	6	6	8	8	10	10	12	12	14
G		1	1	2	2	3	3	4	4	5	5
H		4	4	6	6	8	8	10	10	12	12
J		0	85	85	185	185	285	285	385	385	485
K		0	0	100	200	200	300	300	400	400	500
M		2	2	3	3	3	3	3	3	3	3
N		0	1	1	1	1	1	1	1	1	1
Allowable static load on rod tip (N)	w/o brake	175	147	126	111	98.6	88.7	80.6	73.8	68	63
	w/ brake	75.7	62.6	53.1	46.0	40.5	36.1	32.5	29.4	26.9	24.7
Allowable static torque on rod tip (N·m)	w/o brake	49.8	45.1	40.5	36.5	33.1	30.2	27.7	25.5	23.6	21.9
	w/ brake	17.6	14.7	12.7	11.2	9.9	9.0	8.2	7.5	6.94	6.45
Allowable dynamic torque on rod tip (N·m)	w/o brake	5.0	4.5	4.0	3.6	3.3	3.0	2.8	2.5	2.32	2.16
	w/ brake	4.0	4.3	4.6	4.8	5.1	5.4	5.7	5.9	6.2	6.5
Mass (kg)	RCP6 w/o brake	4.4	4.7	5.0	5.3	5.5	5.8	6.1	6.4	6.7	6.9
	RCP6S w/o brake	4.2	4.5	4.7	5.0	5.3	5.6	5.8	6.1	6.4	6.7
	w/ brake	4.6	4.9	5.2	5.5	5.7	6.0	6.3	6.6	6.8	7.1

② Applicable Controllers

The RCP6 series actuators can be operated by the controllers indicated below. Please select the type depending on your intended use. * Please refer to P.271 for more information about the built-in controller of RCP6S series.

Name	External view	Max. number of controlled axes	Input power	Control method				Maximum number of positioning points	Reference page
				Positioner	Pulse train	Program	Network * Option		
PCON-CYB/PLB/POB		1	DC24V	●	●	-	Network cannot be selected	64	Please contact IAI for more information.
PCON-CB/CGB		1		* Option	* Option	-	DeviceNet MECHATROLINK CC-Link EtherCAT EtherNet/IP CANopen CompoNet	512 (768 for network spec.)	Please see P.255
MCON-C/CG		8		This model is network-compatible only.					
MCON-LC/LCG		6		-	-	●	256	Please contact IAI for more information.	
MSEL-PC/PG		4	Single-phase 100 ~ 230 VAC	-	-	●	30,000	Please contact IAI for more information.	
RCM-P6PC		1		Usable within the RCP6S Gateway system.				768	Please see P.279

* For the MCON controller, high-output enabled operation is only available if "high-output setting" is selected as an option. The maximum connectable axes with high-output enabled are C: 4 and LC: 3.

Foreword
Slider Type
Wide Slider Type
Rod Type
Radial Cylinder
Wide Radial Cylinder
Table Type
Cleanroom Slider
Cleanroom Wide Slider
Dust/Splash-Proof Rod
Dust/Splash-Proof Radial Cylinder
Dust/Splash-Proof Wide Radial Cylinder
Options
Reference Data
Controller

RCP6(S)-RRA8C

Battery-less Absolute Motor Unit Type Coupled Motor Body Width 85 mm 24v Stepper Motor

Model Specification Items	Series	Type	Encoder Type	Motor Type	Lead	Stroke	Applicable Controller/I/O Type	Cable Length	Options
RCP6: Separate Controller RCP6S: Built-in Controller	RRA8C	WA	60P	20: 20mm 10: 10mm 5: 5mm	50: 50mm 700: 700mm (50mm increments)	[RCP6] P4: PCON-CFB/CGFB [RCP6S] SE: SIO Type	N: None P: 1m S: 3m M: 5m X□□: Specified Length R□□: Robot Cable	Please refer to the options table below.	

* RCP6 does not include a controller. RCP6S includes a built-in controller.
* Please refer to P.16 for more information about the model specification items.

Radial Load OK

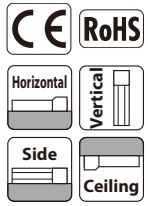

*Some limitations may apply to horizontal/side/ceiling mountings depending on the model. See page 204. Please contact IAI for more information.

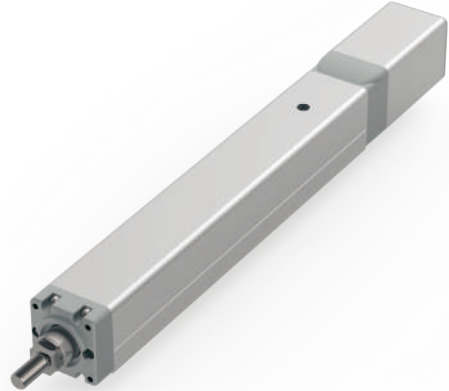

- POINT Selection Notes**
- (1) The maximum acceleration/deceleration is 0.1G for lead 5 and 0.2G for lead 10/20.
 - (2) The actuator specification displays the payload's maximum value, but it will vary depending on the acceleration and speed. Please refer to the "Selection Guidelines" (Tables of Payload by Speed/Acceleration) on P.215 for more details.
 - (3) The radial cylinder is equipped with a built-in guide. Please refer to the graphs shown in P.243 and after for the allowable load mass.
 - (4) Please refer to P205 for performing push-motion operation.
 - (5) For RCP6S (built-in controller type), please limit the duty cycle to 70% or less.
 - (6) The service life of an actuator varies depending on the payload when using vertically. Please refer to P. 206 for more information.

Correlation Diagrams of Speed and Payload

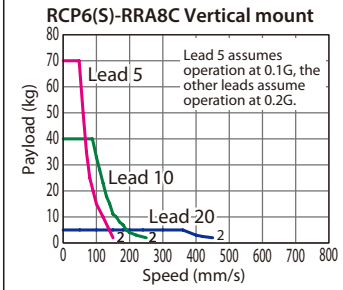
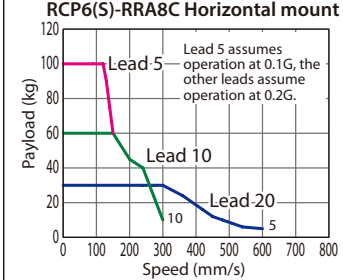

Actuator Specifications

Lead and Payload * Horizontal external guide rail required for horizontal payload. ** Push force only available during push mode w / limited speed.

Model Number	Lead (mm)	Max. Payload		Stroke (mm)
		Horizontal (kg) *	Vertical (kg)	
RCP6(S)-RRA8C-WA-60P-20-①-②-③-④	20	30	5	50~700 (The increment of stroke is 50mm)
RCP6(S)-RRA8C-WA-60P-10-①-②-③-④	10	60	40	
RCP6(S)-RRA8C-WA-60P-5-①-②-③-④	5	100	70	

Stroke and Max. Speed (Unit: mm/s)

Lead (mm)	50 (mm)	100 (mm)	150 (mm)	200 (mm)	250-350 (mm)	400 (mm)	450 (mm)	500 (mm)	550 (mm)	600 (mm)	650 (mm)	700 (mm)
20	280	405	505 <450>	585 <450>	600 <450>	520 <450>	440	360	320	280	240	220
10	280 <250>		300 <250>		260 <250>	220	180	160	140	120	110	
5		150			130	110	90	80	70	60	55	

Legend: ① Stroke ② Applicable controller/I/O type ③ Cable length ④ Options Values in brackets < > are for vertical use.

① Stroke

Stroke (mm)	RCP6	RCP6S	Stroke (mm)	RCP6	RCP6S
50	○	○	400	○	○
100	○	○	450	○	○
150	○	○	500	○	○
200	○	○	550	○	○
250	○	○	600	○	○
300	○	○	650	○	○
350	○	○	700	○	○

③ Cable Length

Cable Type	Cable Code	RCP6	RCP6S
Standard	P (1m)	○	○
	S (3m)	○	○
	M (5m)	○	○
Specified Length	X06 (6m) ~X10 (10m)	○	○
	X11 (11m) ~X15 (15m)	○	○
	X16 (16m) ~X20 (20m)	○	○
	R01 (1m) ~R03 (3m)	○	○
Robot Cable	R04 (4m) ~R05 (5m)	○	○
	R06 (6m) ~R10 (10m)	○	○
	R11 (11m) ~R15 (15m)	○	○
	R16 (16m) ~R20 (20m)	○	○

* Please refer to P.267 and 283 for more information regarding the maintenance cables.

④ Options

Name	Option Code	Reference Page
Brake	B	See P.189
Cable exit direction (Top)	CJT	See P.189
Cable exit direction (Right)	CJR	See P.189
Cable exit direction (Left)	CJL	See P.189
Cable exit direction (Bottom)	CJB	See P.189
Flange	FL	See P.190
Tip adapter (Internal thread)	NFA	See P.193
Non-motor end specification	NM	See P.194

When selecting multiple options, please list them in alphabetical order. (e.g. B-CJB-NM)

Actuator Specifications

Item	Description
Drive system	Ball screw φ16mm, rolled C10
Positioning repeatability	±0.01mm
Lost motion	0.1mm or less
Rod	φ40mm Aluminum
Rod non-rotation precision*	0 deg.
Allowable load and torque on rod tip	See P. 243
Rod tip overhang distance	150mm or less
Ambient operating temp. & humidity	0~40°C, 85% RH or less (Non-condensing)

* Rod's angular displacement in rotational direction with no load applied to the rod.

CAD drawings can be downloaded from our website.
www.intelligentactuator.com



- *1 When the rod is returning to its home position, please be careful of interference from surrounding objects, as it will travel until it reaches the M.E. M.E: Mechanical end S.E: Stroke end
- *2 The direction of width across flats varies depending on the product.
- *3 When fixing the actuator using a front bracket or flange, please make sure that there is no external force applied to the main body.

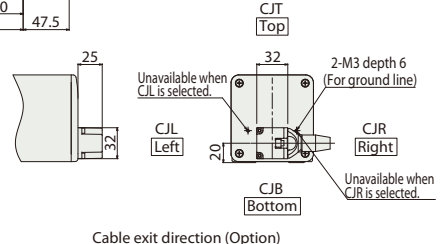
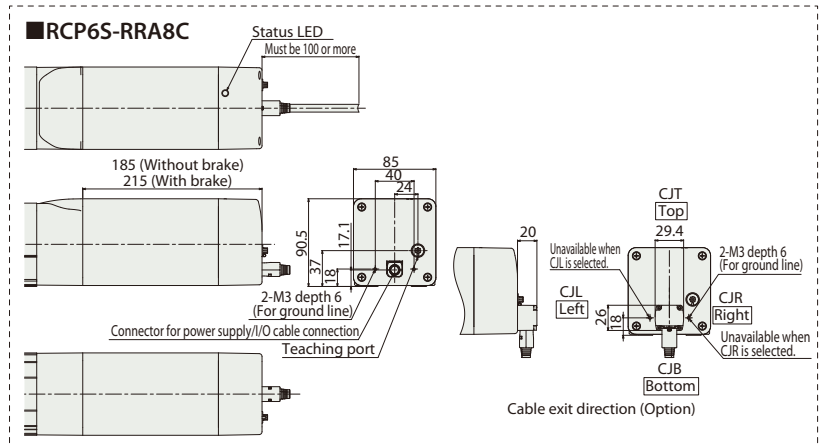
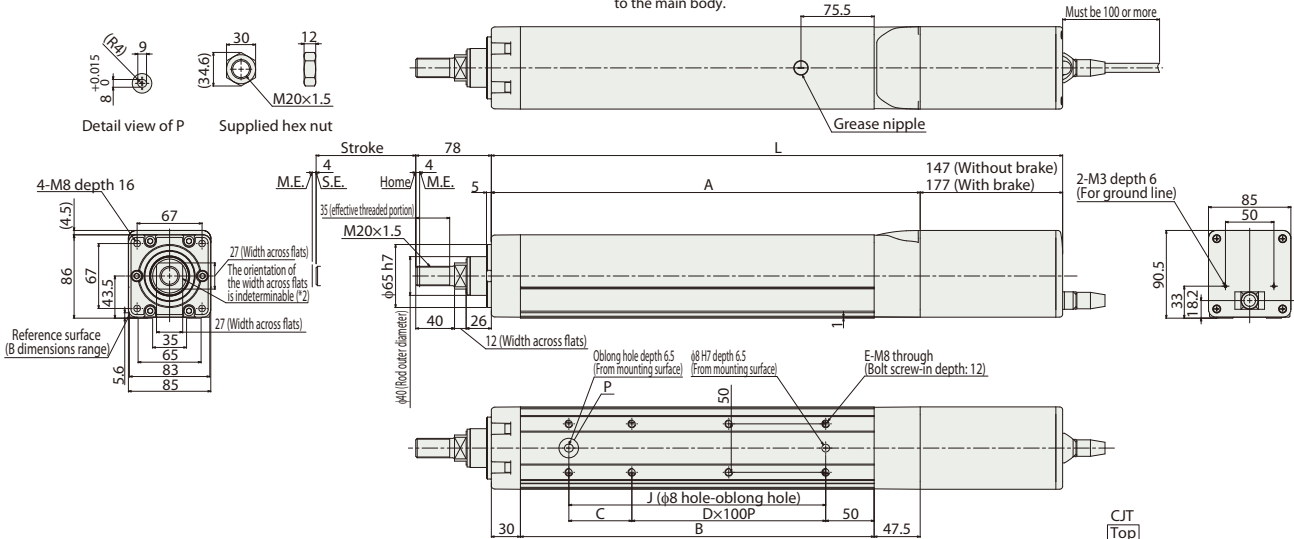

■ Rod Deflection of RCP6(S)-RRA8C (Reference Values)

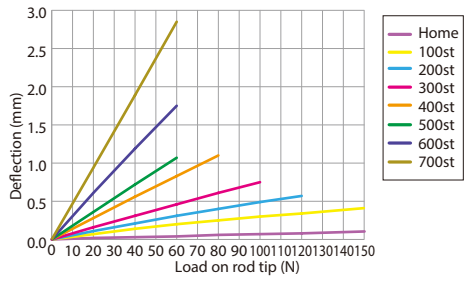

■ Dimensions and Mass by Stroke

L	Stroke	50	100	150	200	250	300	350	400	450	500	550	600	650	700
		RCP6	w/o brake	439.5	489.5	539.5	589.5	639.5	689.5	739.5	789.5	839.5	889.5	939.5	989.5
	w/ brake	469.5	519.5	569.5	619.5	669.5	719.5	769.5	819.5	869.5	919.5	969.5	1,019.5	1,069.5	1,119.5
	RCP6S	w/o brake	477.5	527.5	577.5	627.5	677.5	727.5	777.5	827.5	877.5	927.5	977.5	1,027.5	1,077.5
	w/ brake	507.5	557.5	607.5	657.5	707.5	757.5	807.5	857.5	907.5	957.5	1,007.5	1,057.5	1,107.5	1,157.5
	A	292.5	342.5	392.5	442.5	492.5	542.5	592.5	642.5	692.5	742.5	792.5	842.5	892.5	942.5
	B	215	265	315	365	415	465	515	565	615	665	715	765	815	865
	C	115	65	115	65	115	65	115	65	115	65	115	65	115	65
	D	0	1	1	2	2	3	3	4	4	5	5	6	6	7
	E	4	6	6	8	8	10	10	12	12	14	14	16	16	18
	J	115	165	215	265	315	365	415	465	515	565	615	665	715	765
	Allowable static load on rod tip (N)	222	186	159	139	124	111	101	92.1	84.7	78.4	72.8	68	63.7	59.8
	Allowable dynamic load on rod tip (5000km life) (N)	72.0	61.6	53.9	48.0	43.0	38.9	35.4	32.3	29.7	27.4	25.3	23.5	21.9	20.4
	Allowable static torque on rod tip (N·m)	22.3	18.7	16.1	14.1	12.6	11.3	10.3	9.4	8.7	8.1	7.6	7.1	6.7	6.3
	Allowable dynamic torque on rod tip (N·m)	7.2	6.2	5.4	4.8	4.3	3.9	3.5	3.2	3.0	2.7	2.5	2.4	2.2	2.0
Mass (kg)	RCP6	w/o brake	6.6	7.1	7.6	8.0	8.5	9.0	9.5	10.0	10.4	10.9	11.4	11.8	12.3
	w/ brake	7.2	7.7	8.2	8.6	9.1	9.6	10.1	10.5	11.0	11.5	11.9	12.4	12.9	13.4
	RCP6S	w/o brake	7.0	7.4	7.9	8.4	8.8	9.3	9.8	10.3	10.7	11.2	11.7	12.1	12.6
	w/ brake	7.5	8.0	8.5	9.0	9.4	9.9	10.4	10.8	11.3	11.8	12.3	12.7	13.2	13.7

② Applicable Controllers

The RCP6 series actuators can be operated by the controllers indicated below. Please select the type depending on your intended use.* Please refer to P.271 for more information about the built-in controller of RCP6S series.

Name	External view	Max. number of controlled axes	Input power	Control method			Maximum number of positioning points	Reference page
				Positioner	Pulse train	Program		
PCON-CFB/CGFB		1	DC24V	●	●	-	512 (768 for network spec.)	Please see P.255
				*Option	*Option			
Control method: Network * Option DeviceNet, CompoNet, EtherNet/IP, CC-Link, MECHATROLINK, EtherCAT, CANopen								

Foreword
 Slider Type
 Wide Slider Type
 Rod Type
 Radial Cylinder
 Wide Radial Cylinder
 Table Type
 Cleanroom Slider
 Cleanroom Wide Slider
 Dust/Splash-Proof Rod
 Dust/Splash-Proof Radial Cylinder
 Dust/Splash-Proof Wide Radial Cylinder
 Options
 Reference Data
 Controller

RCP6(S)-RRA4R

Battery-less Absolute

Motor Unit Type

Side-mounted Motor

Body Width 40mm*

24v Stepper Motor

Model Specification Items

Series — Type — Encoder Type — Motor Type — Lead — Stroke — Applicable Controller/I/O Type — Cable Length — Options

RCP6: Separate Controller
RCP6S: Built-in Controller

WA: Battery-less Absolute
35P: Stepper Motor 35□ Size

16: 16mm
10: 10mm
5: 5mm
2.5: 2.5mm

[RCP6]
P3: PCON
MCON
MSEL
P5: RCM-P6PC
[RCP6S]
SE: SIO Type

N: None
P: 1m
S: 3m
M: 5m
□□□: Specified Length
R□□: Robot Cable

Please refer to the options table below.

*Please make sure to specify either ML or MR when ordering the side-mounted motor type.

* Body width does not include the width of the side-mounted motor.

* RCP6 does not include a controller. RCP6S includes a built-in controller.
* Please refer to P.16 for more information about the model specification items.

Radial Load OK

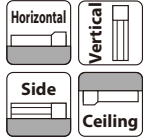

*Some limitations may apply to horizontal/side/ceiling mountings depending on the model. See page 204. Please contact IAI for more information.



The figure above is the motor side-mounted to the left (ML).

- POINT Selection Notes**
- (1) The maximum acceleration/deceleration is 1G for horizontal, and 0.5G for vertical use.
 - (2) The actuator specification displays the payload's maximum value, but it will vary depending on the acceleration and speed. Please refer to the "Selection Guidelines" (Tables of Payload by Speed/Acceleration) on P.217 for more details.
 - (3) The radial cylinder is equipped with a built-in guide. Please refer to the graphs shown in P.243 and after for the allowable load mass.
 - (4) Please refer to P205 for performing push-motion operation.

Correlation Diagrams of Speed and Payload

(1) High-output enabled with PCON/MCON/MSEL connected.

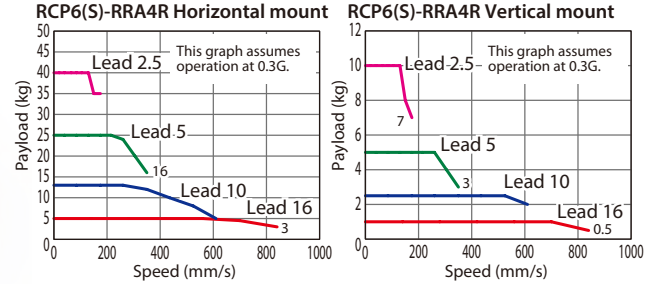

(2) High-output disabled with PCON/MCON connected.

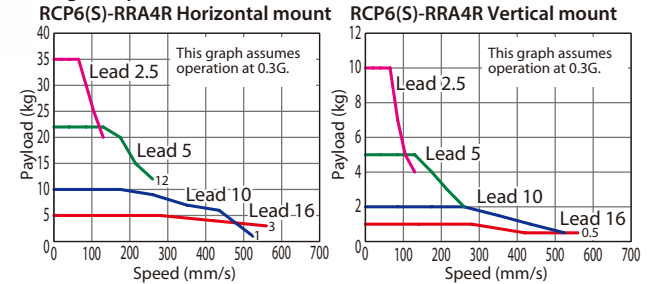

Actuator Specifications

Lead and Payload

* Horizontal external guide rail required for horizontal payload.
** Push force only available during push mode w / limited speed.

Model Number	Lead (mm)	Connected Controller	Max. Payload		Max. Push Force (N)**	Stroke (mm)
			Horizontal (kg)*	Vertical (kg)		
RCP6(S)-RRA4R-WA-35P-16-①-②-③-④	16	High-output Enabled	5	1	48	60~410 (The increment of stroke is 50mm)
		High-output Disabled	5	1		
RCP6(S)-RRA4R-WA-35P-10-①-②-③-④	10	High-output Enabled	13	2.5	77	
		High-output Disabled	10	2		
RCP6(S)-RRA4R-WA-35P-5-①-②-③-④	5	High-output Enabled	28	5	155	
		High-output Disabled	22	5		
RCP6(S)-RRA4R-WA-35P-2.5-①-②-③-④	2.5	High-output Enabled	40	10	310	
		High-output Disabled	35	10		

Legend: ① Stroke ② Applicable controller/I/O type ③ Cable length ④ Options

Stroke and Max. Speed

(Unit: mm/s)

Lead (mm)	Connected Controller	60~360 (Every 50mm)		410 (mm)
		60~360 (Every 50mm)	410 (mm)	
16	High-output Enabled	840		
	High-output Disabled	560		
10	High-output Enabled	610		
	High-output Disabled	525		
5	High-output Enabled	350	340	
	High-output Disabled	260		
2.5	High-output Enabled	175	170	
	High-output Disabled	130		

① Stroke

Stroke (mm)	RCP6	RCP6S	Stroke (mm)	RCP6	RCP6S
60	○	○	260	○	○
110	○	○	310	○	○
160	○	○	360	○	○
210	○	○	410	○	○

④ Options

Name	Option Code	Reference Page
Brake	B	See P.189
Cable exit direction (Outside)	CJO	See P.189
Flange	FL	See P.190
Tip adapter (Flange)	FFA	See P.189
Tip adapter (Internal thread)	NFA	See P.192
Tip adapter (Keyway)	KFA	See P.193
Motor side-mounted to the left	ML	See P.193
Motor side-mounted to the right	MR	See P.193
Knuckle joint	NJ	See P.194
Non-motor end specification	NM	See P.194
Clevis bracket	QR	See P.195

* Be sure to confirm with the "Selection Notes (P.196)" when selecting options.
When selecting multiple options, please list them in alphabetical order. (e.g. B-CJB-NM)

③ Cable Length

Cable Type	Cable Code	RCP6			RCP6S
		P3	P5	SE	
Standard	P (1m)	○	○	○	○
	S (3m)	○	○	○	○
	M (5m)	○	○	○	○
Specified Length	X06 (6m) ~X10 (10m)	○	○	○	○
	X11 (11m) ~X15 (15m)	○	○	○	○
	X16 (16m) ~X20 (20m)	○	○	○	○
	R01 (1m) ~R03 (3m)	○	○	○	○
Robot Cable	R04 (4m) ~R05 (5m)	○	○	○	○
	R06 (6m) ~R10 (10m)	○	○	○	○
	R11 (11m) ~R15 (15m)	○	○	○	○
	R16 (16m) ~R20 (20m)	○	○	○	○
		○	○	○	○

* Please refer to P.267 and 283 for more information regarding the maintenance cables.

Actuator Specifications

Item	Description
Drive system	Ball screw φ8mm, rolled C10
Positioning repeatability	±0.01mm
Lost motion	0.1mm or less
Rod	φ20mm Aluminum
Rod non-rotation precision*	0 deg.
Allowable load and torque on rod tip	See P. 243
Rod tip overhang distance	100mm or less
Ambient operating temp. & humidity	0~40°C, 85% RH or less (Non-condensing)

* Rod's angular displacement in rotational direction with no load applied to the rod.

CAD drawings can be downloaded from our website.
www.intelligentactuator.com



- *1 When the rod is returning to its home position, please be careful of interference from surrounding objects, as it will travel until it reaches the M.E. M.E: Mechanical end S.E: Stroke end
- *2 The direction of width across flats varies depending on the product.
- *3 When fixing the actuator using a front bracket or flange, please make sure that there is no external force applied to the main body.

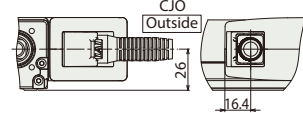
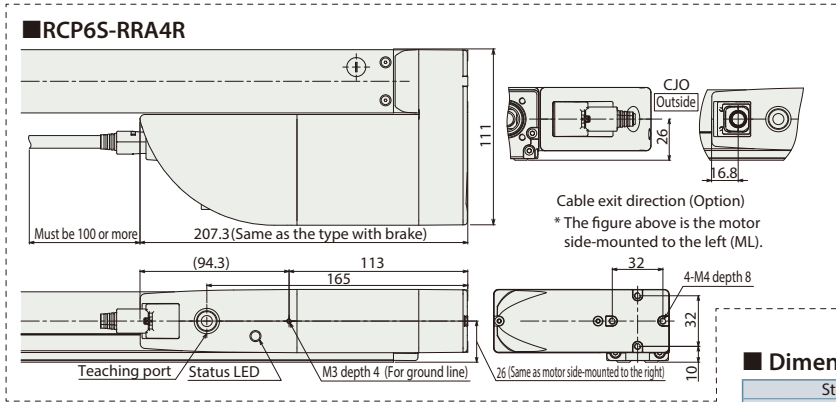
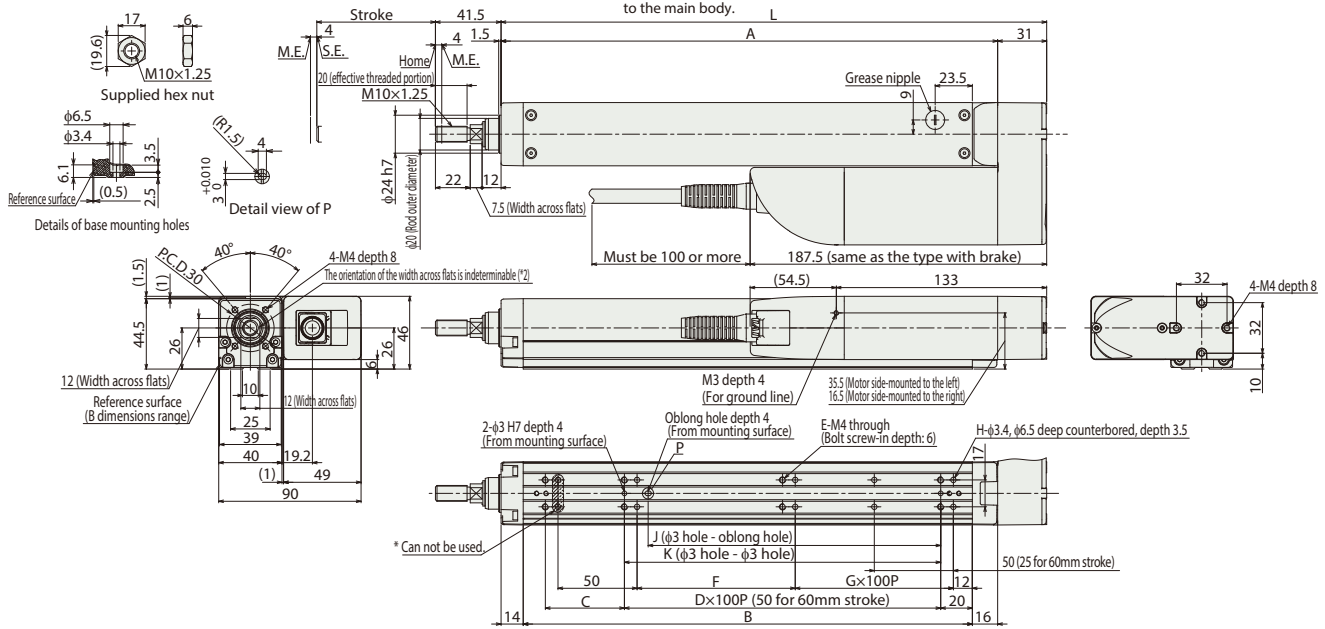

Cable exit direction (Option)
* The figure above is the motor side-mounted to the left (ML).

* The two mounting holes (H) on the rod side of the top surface of the base can not be used. The number of the holes (H) in the table does not include these holes that cannot be used.

■ Dimensions and Mass by Stroke

Stroke	60	110	160	210	260	310	360	410	
L	195	245	295	345	395	445	495	545	
A	164	214	264	314	364	414	464	514	
B	134	184	234	284	334	384	434	484	
C	50	50	100	50	100	50	100	50	
D	0	1	1	2	2	3	3	4	
E	6	6	6	8	8	10	10	12	
F	50	100	50	100	50	100	50	100	
G	0	0	1	1	2	2	3	3	
H	6	6	8	8	10	10	12	12	
J	35	85	85	185	185	285	285	385	
K	50	100	100	200	200	300	300	400	
Allowable static load on rod tip (N)	63.4	50.7	42.1	36	31.3	27.6	24.6	22.2	
Allowable dynamic load on rod tip (5000km life) (N)	28.9	22.2	17.9	14.8	12.6	10.8	9.4	8.2	
Allowable static torque on rod tip (N·m)	6.4	5.1	4.3	3.7	3.2	2.9	2.6	2.3	
Allowable dynamic torque on rod tip (N·m)	1.7	1.5	1.3	1.1	1.0	0.9	0.7	0.7	
Mass (kg)	RCP6	w/o brake	1.4	1.5	1.6	1.8	1.9	2.0	2.1
		w/ brake	1.4	1.6	1.7	1.8	1.9	2.1	2.2
	RCP6S	w/o brake	1.5	1.6	1.8	1.9	2.0	2.1	2.3
		w/ brake	1.6	1.7	1.8	1.9	2.1	2.2	2.3

■ Rod Deflection of RCP6(S)-RRA4R (Reference Values)

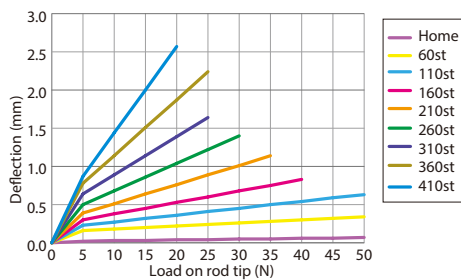

② Applicable Controllers

The RCP6 series actuators can be operated by the controllers indicated below. Please select the type depending on your intended use. * Please refer to P.271 for more information about the built-in controller of RCP6S series.

Name	External view	Max. number of controlled axes	Input power	Control method				Maximum number of positioning points	Reference page
				Positioner	Pulse train	Program	Network * Option		
PCON-CYB/PLB/POB		1	DC24V	●	●	-	Network cannot be selected	64	Please contact IAI for more information.
PCON-CB/CGB		1		* Option	* Option	-	MECHATROLINK EtherCAT 	512 (768 for network spec.)	Please see P.255
MCON-C/CG		8		This model is network-compatible only.					256
MCON-LC/LCG		6		-	-	●	256		Please contact IAI for more information.
MSEL-PC/PG		4	Single-phase 100 ~ 230 VAC	-	-	●	30,000	Please contact IAI for more information.	
RCM-P6PC		1	Usable within the RCP6S Gateway system.				768	Please see P.279	

* For the MCON controller, high-output enabled operation is only available if "high-output setting" is selected as an option. The maximum connectable axes with high-output enabled are C: 4 and LC: 3.

Foreword
Slider Type
Wide Slider Type
Rod Type
Radial Cylinder
Wide Radial Cylinder
Table Type
Cleanroom Slider
Cleanroom Wide Slider
Dust/Splash-Proof Rod
Dust/Splash-Proof Radial Cylinder
Dust/Splash-Proof Wide Radial Cylinder
Options
Reference Data
Controller

RCP6(S)-RRA6R

Battery-less Absolute

Motor Unit Type

Side-mounted Motor

Body Width 58* mm

24v Stepper Motor

Model Specification Items

Series	Type	Encoder Type	Motor Type	Lead	Stroke	Applicable Controller/I/O Type	Cable Length	Options
RCP6: Separate Controller RCP6S: Built-in Controller	RRA6R	WA: Battery-less Absolute	42P: Stepper Motor 42□ Size	20: 20mm 12: 12mm 6: 6mm 3: 3mm	65: 65mm 415: 415mm (50mm increments)	[RCP6] P3: PCON MCON MSEL P5: RCM-P6PC [RCP6S] SE: SIO Type	N: None P: 1m S: 3m M: 5m X□□: Specified Length R□□: Robot Cable	Please refer to the options table below. *Please make sure to specify either ML or MR when ordering the side-mounted motor type.

* Body width does not include the width of the side-mounted motor.

* RCP6 does not include a controller. RCP6S includes a built-in controller.
* Please refer to P.16 for more information about the model specification items.

Radial Load OK

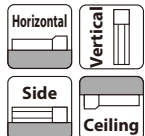

*Some limitations may apply to horizontal/side/ceiling mountings depending on the model. See page 204. Please contact IAI for more information.



The figure above is the motor side-mounted to the left (ML).

	(1) The maximum acceleration/deceleration is 1G for horizontal, and 0.5G for vertical use.
	(2) The actuator specification displays the payload's maximum value, but it will vary depending on the acceleration and speed. Please refer to the "Selection Guidelines" (Tables of Payload by Speed/Acceleration) on P.217 for more details.
	(3) The radial cylinder is equipped with a built-in guide. Please refer to the graphs shown in P.243 and after for the allowable load mass.
	(4) Please refer to P.205 for performing push-motion operation.
	(5) Depending on the ambient operational temperature, duty control is necessary for the RCP6S (built-in controller type) with lead 3/6. Please refer to P.247 for more information.

Correlation Diagrams of Speed and Payload

(1) High-output enabled with PCON/MCON/MSEL connected.

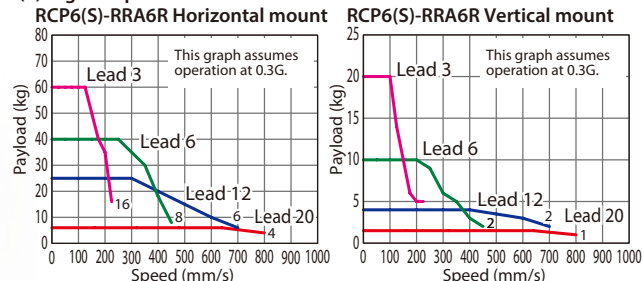

(2) High-output disabled with PCON/MCON connected.

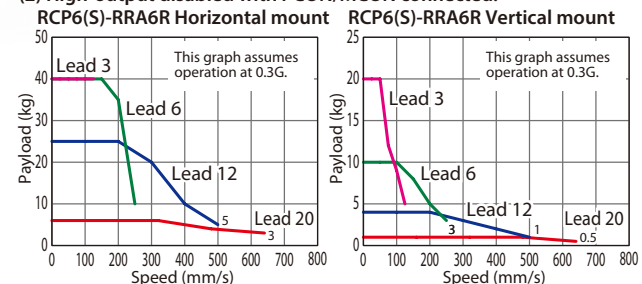

Actuator Specifications

Lead and Payload

* Horizontal external guide rail required for horizontal payload.
** Push force only available during push mode w / limited speed.

Model Number	Lead (mm)	Connected Controller	Max. Payload		Max. Push Force (N)**	Stroke (mm)
			Horizontal (kg)*	Vertical (kg)		
RCP6(S)-RRA6R-WA-42P-20-①-②-③-④	20	High-output Enabled	6	1.5	56	65~415 (The increment of stroke is 50mm)
		High-output Disabled	6	1		
RCP6(S)-RRA6R-WA-42P-12-①-②-③-④	12	High-output Enabled	25	4	93	
		High-output Disabled	25	4		
RCP6(S)-RRA6R-WA-42P-6-①-②-③-④	6	High-output Enabled	40	10	185	
		High-output Disabled	40	10		
RCP6(S)-RRA6R-WA-42P-3-①-②-③-④	3	High-output Enabled	60	20	370	
		High-output Disabled	40	20		

Legend: ① Stroke ② Applicable controller/I/O type ③ Cable length ④ Options

Stroke and Max. Speed

(Unit: mm/s)

Lead (mm)	Connected Controller	65~365 (Every 50mm)	415 (mm)
20	High-output Enabled	800	
	High-output Disabled	640	
12	High-output Enabled	700	
	High-output Disabled	500	
6	High-output Enabled	450	
	High-output Disabled	250	
3	High-output Enabled	225	220
	High-output Disabled	125	

① Stroke

Stroke (mm)	RCP6	RCP6S	Stroke (mm)	RCP6	RCP6S
65	○	○	265	○	○
115	○	○	315	○	○
165	○	○	365	○	○
215	○	○	415	○	○

④ Options

Name	Option Code	Reference Page
Brake	B	See P.189
Cable exit direction (Outside)	CJO	See P.189
Flange	FL	See P.190
Tip adapter (Flange)	FFA	See P.189
Tip adapter (Internal thread)	NFA	See P.192
Tip adapter (Keyway)	KFA	See P.193
Motor side-mounted to the left	ML	See P.193
Motor side-mounted to the right	MR	See P.193
Knuckle joint	NJ	See P.194
Non-motor end specification	NM	See P.194
Clevis bracket	QR	See P.195

* Be sure to confirm with the "Selection Notes (P.196)" when selecting options.
When selecting multiple options, please list them in alphabetical order. (e.g. B-CJB-NM)

③ Cable Length

Cable Type	Cable Code	RCP6			RCP6S
		P3	P5	SE	
Standard	P (1m)	○	○	○	○
	S (3m)	○	○	○	○
	M (5m)	○	○	○	○
Specified Length	X06 (6m) ~X10 (10m)	○	○	○	○
	X11 (11m) ~X15 (15m)	○	○	○	○
	X16 (16m) ~X20 (20m)	○	○	○	○
	R01 (1m) ~R03 (3m)	○	○	○	○
Robot Cable	R04 (4m) ~R05 (5m)	○	○	○	○
	R06 (6m) ~R10 (10m)	○	○	○	○
	R11 (11m) ~R15 (15m)	○	○	○	○
	R16 (16m) ~R20 (20m)	○	○	○	○

* Please refer to P.267 and 283 for more information regarding the maintenance cables.

Actuator Specifications

Item	Description
Drive system	Ball screw φ10mm, rolled C10
Positioning repeatability	±0.01mm
Lost motion	0.1mm or less
Rod	φ25mm Aluminum
Rod non-rotation precision*	0 deg.
Allowable load and torque on rod tip	See P. 243
Rod tip overhang distance	100mm or less
Ambient operating temp. & humidity	0~40°C, 85% RH or less (Non-condensing)

* Rod's angular displacement in rotational direction with no load applied to the rod.

CAD drawings can be downloaded from our website.
www.intelligentactuator.com



- *1 When the rod is returning to its home position, please be careful of interference from surrounding objects, as it will travel until it reaches the M.E. M.E: Mechanical end S.E: Stroke end
- *2 The direction of width across flats varies depending on the product.
- *3 When fixing the actuator using a front bracket or flange, please make sure that there is no external force applied to the main body.

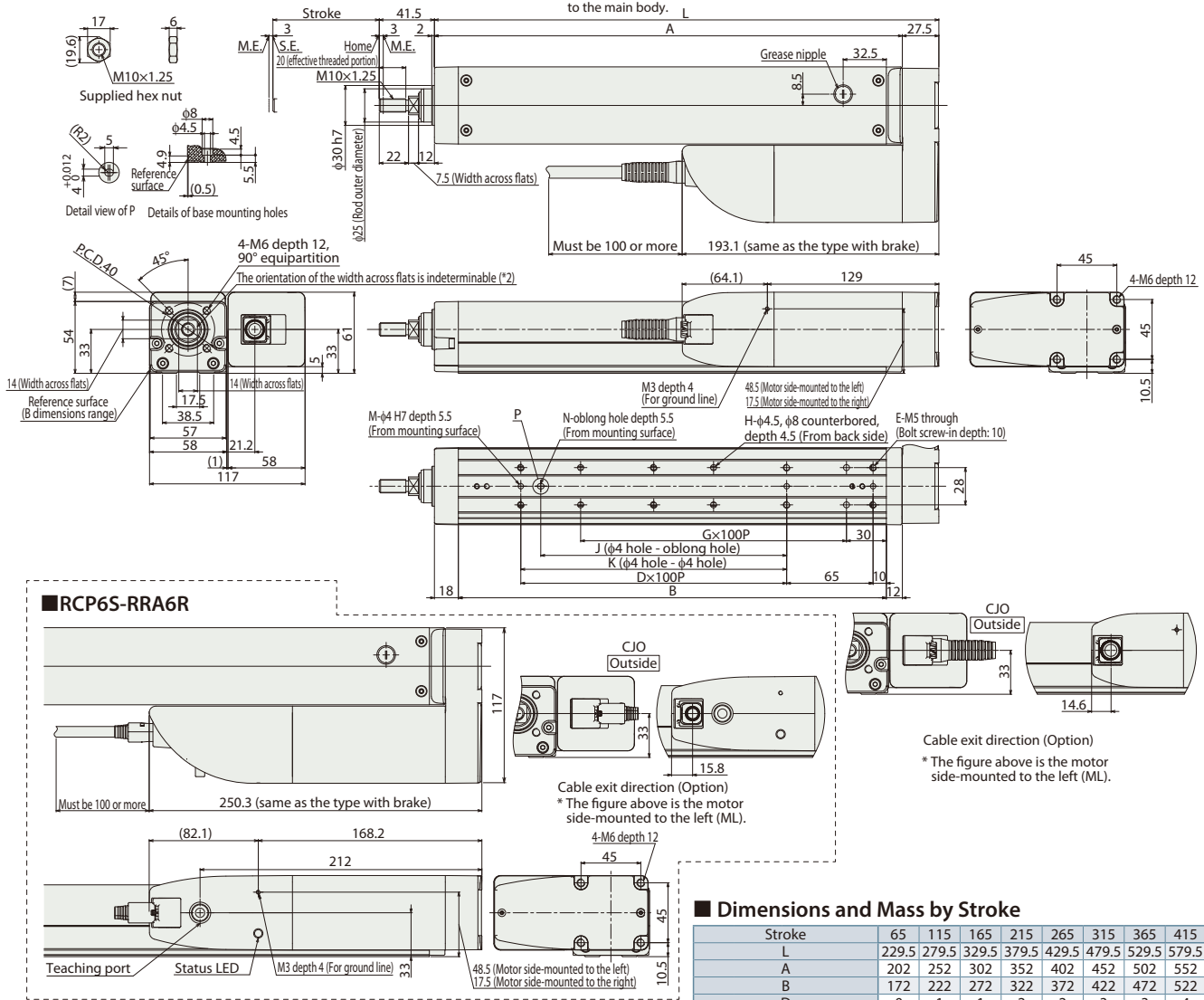

■ Rod Deflection of RCP6(S)-RRR6R (Reference Values)

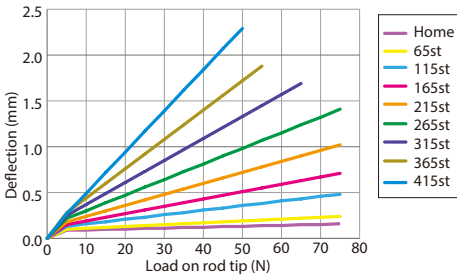

■ Dimensions and Mass by Stroke

Stroke	65	115	165	215	265	315	365	415
L	229.5	279.5	329.5	379.5	429.5	479.5	529.5	579.5
A	202	252	302	352	402	452	502	552
B	172	222	272	322	372	422	472	522
D	0	1	1	2	2	3	3	4
E	4	6	6	8	8	10	10	12
G	1	1	2	2	3	3	4	4
H	4	4	6	6	8	8	10	10
J	0	85	85	185	185	285	285	385
K	0	100	100	200	200	300	300	400
M	2	3	3	3	3	3	3	3
N	0	1	1	1	1	1	1	1
Allowable static load on rod tip (N)	144	117	99	85.4	75	66.7	59.9	54.3
Allowable dynamic load on rod tip (5000km life) (N)	58.1	46.4	38.3	32.4	27.9	24.4	21.5	19.2
Allowable static torque on rod tip (N·m)	38.8	34.0	29.7	26.2	23.2	20.8	18.7	16.8
Allowable dynamic torque on rod tip (N·m)	14.5	11.8	10.0	8.7	7.6	6.8	6.2	5.6
Mass (kg)	RCP6		RCP6S		RCP6		RCP6S	
	w/o brake	2.4	2.6	2.9	3.1	3.3	3.5	3.8
	w/ brake	2.5	2.7	2.9	3.2	3.4	3.6	3.8
	w/ brake	2.6	2.8	3.0	3.2	3.4	3.7	3.9

② Applicable Controllers

The RCP6 series actuators can be operated by the controllers indicated below. Please select the type depending on your intended use. * Please refer to P.271 for more information about the built-in controller of RCP6S series.

Name	External view	Max. number of controlled axes	Input power	Control method				Maximum number of positioning points	Reference page
				Positioner	Pulse train	Program	Network * Option		
PCON-CYB/PLB/POB		1	DC24V	●	●	-	Network cannot be selected	64	Please contact IAI for more information.
PCON-CB/CGB		1		* Option	* Option	-	DeviceNet CC-Link EtherCAT EtherNet/IP CANopen CompoNet	512 (768 for network spec.)	Please see P.255
MCON-C/CG		8		This model is network-compatible only.				Note: The type of compatible networks will vary depending on the controller. Please refer to reference page for more information.	256
MCON-LC/LCG		6		-	-	●	256		Please contact IAI for more information.
MSEL-PC/PG		4	Single-phase 100 ~ 230 VAC	-	-	●	30,000	Please contact IAI for more information.	
RCM-P6PC		1	Usable within the RCP6S Gateway system.				768	Please see P.279	

* For the MCON controller, high-output enabled operation is only available if "high-output setting" is selected as an option. The maximum connectable axes with high-output enabled are C: 4 and LC: 3.

Foreword
Slider Type
Wide Slider Type
Rod Type
Radial Cylinder
Wide Radial Cylinder
Table Type
Cleanroom Slider
Cleanroom Wide Slider
Dust/Splash-Proof Rod
Dust/Splash-Proof Radial Cylinder
Dust/Splash-Proof Wide Radial Cylinder
Options
Reference Data
Controller

RCP6(S)-RRA7R

Battery-less Absolute

Motor Unit Type

Side-mounted Motor

Body Width 70mm*

24v Stepper Motor

Model Specification Items

Series: RCP6 — RRA7R — WA — 56P — Lead — Stroke — Applicable Controller/I/O Type — Cable Length — Options

RCP6: Separate Controller
RCP6S: Built-in Controller

WA: Battery-less Absolute
56P: Stepper Motor 56□ Size

Lead: 24: 24mm, 16: 16mm, 8: 8mm, 4: 4mm
Stroke: 70: 70mm, 520: 520mm (50mm increments)

[RCP6] P3: PCON, MCON, MSEL
P5: RCM-P6PC [RCP6S] SE: SIO Type

N: None
P: 1m
S: 3m
M: 5m
X□□: Specified Length
R□□: Robot Cable

Please refer to the options table below.
*Please make sure to specify either ML or MR when ordering the side-mounted motor type.

* RCP6 does not include a controller. RCP6S includes a built-in controller.
* Please refer to P.16 for more information about the model specification items.

* Body width does not include the width of the side-mounted motor.

Radial Load OK

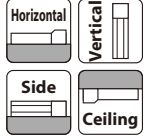

*Some limitations may apply to horizontal/side/ceiling mountings depending on the model. See page 204. Please contact IAI for more information.



The figure above is the motor side-mounted to the left (ML).

	(1) The maximum acceleration/deceleration is 1G for horizontal, and 0.5G for vertical use.
	(2) The actuator specification displays the payload's maximum value, but it will vary depending on the acceleration and speed. Please refer to the "Selection Guidelines" (Tables of Payload by Speed/Acceleration) on P.217 for more details.
	(3) The radial cylinder is equipped with a built-in guide. Please refer to the graphs shown in P.243 and after for the allowable load mass.
	(4) Please refer to P.205 for performing push-motion operation.
	(5) Depending on the ambient operational temperature, duty control is necessary for the RCP6S (built-in controller type) with lead 4/8/16. Please refer to P.247 for more information.

Correlation Diagrams of Speed and Payload

(1) High-output enabled with PCON/MCON/MSEL connected.

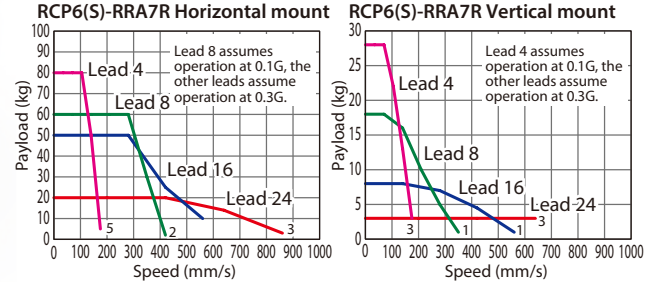

(2) High-output disabled with PCON/MCON connected.

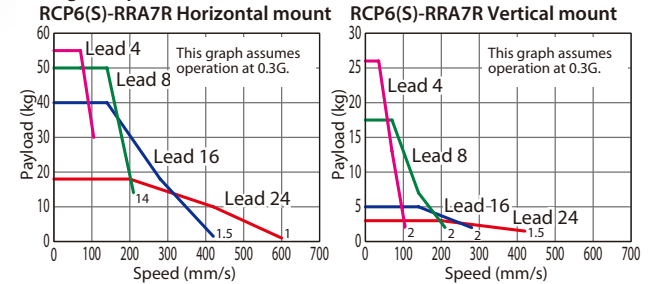

Actuator Specifications

Lead and Payload

* Horizontal external guide rail required for horizontal payload.
** Push force only available during push mode w / limited speed.

Model Number	Lead (mm)	Connected Controller	Max. Payload		Max. Push Force (N)**	Stroke (mm)
			Horizontal (kg)*	Vertical (kg)		
RCP6(S)-RRA7R-WA-56P-24-①-②-③-④	24	High-output Enabled	20	3	182	70~520 (The increment of stroke is 50mm)
		High-output Disabled	18	3		
RCP6(S)-RRA7R-WA-56P-16-①-②-③-④	16	High-output Enabled	50	8	273	
		High-output Disabled	40	5		
RCP6(S)-RRA7R-WA-56P-8-①-②-③-④	8	High-output Enabled	60	18	547	
		High-output Disabled	50	17.5		
RCP6(S)-RRA7R-WA-56P-4-①-②-③-④	4	High-output Enabled	80	28	1,094	
		High-output Disabled	55	26		

Legend: ① Stroke ② Applicable controller/I/O type ③ Cable length ④ Options

Stroke and Max. Speed

(Unit: mm/s)

Lead (mm)	Connected Controller	70~520 (Every 50mm)
24	High-output Enabled	860 <640>
	High-output Disabled	600 <420>
16	High-output Enabled	560
	High-output Disabled	420 <280>
8	High-output Enabled	420 <350>
	High-output Disabled	210
4	High-output Enabled	175
	High-output Disabled	105

Values in brackets < > are for vertical use.

① Stroke

Stroke (mm)	RCP6	RCP6S	Stroke (mm)	RCP6	RCP6S
70	○	○	320	○	○
120	○	○	370	○	○
170	○	○	420	○	○
220	○	○	470	○	○
270	○	○	520	○	○

④ Options

Name	Option Code	Reference Page
Brake	B	See P.189
Cable exit direction (Outside)	CJO	See P.189
Flange	FL	See P.190
Tip adapter (Flange)	FFA	See P.189
Tip adapter (Internal thread)	NFA	See P.192
Tip adapter (Keyway)	KFA	See P.193
Motor side-mounted to the left	ML	See P.193
Motor side-mounted to the right	MR	See P.193
Knuckle joint	NJ	See P.194
Non-motor end specification	NM	See P.194
Clevis bracket	QR	See P.195

* Be sure to confirm with the "Selection Notes (P.196)" when selecting options.
When selecting multiple options, please list them in alphabetical order. (e.g. B-CJB-NM)

③ Cable Length

Cable Type	Cable Code	RCP6			RCP6S
		P3	P5	SE	
Standard	P (1m)	○	○	○	○
	S (3m)	○	○	○	○
	M (5m)	○	○	○	○
	X06 (6m) ~X10 (10m)	○	○	○	○
Specified Length	X11 (11m) ~X15 (15m)	○	○	○	○
	X16 (16m) ~X20 (20m)	○	○	○	○
	R01 (1m) ~R03 (3m)	○	○	○	○
	R04 (4m) ~R05 (5m)	○	○	○	○
Robot Cable	R06 (6m) ~R10 (10m)	○	○	○	○
	R11 (11m) ~R15 (15m)	○	○	○	○
	R16 (16m) ~R20 (20m)	○	○	○	○

* Please refer to P.267 and 283 for more information regarding the maintenance cables.

Actuator Specifications

Item	Description
Drive system	Ball screw φ12mm, rolled C10
Positioning repeatability	±0.01mm
Lost motion	0.1mm or less
Rod	φ30mm Aluminum
Rod non-rotation precision*	0 deg.
Allowable load and torque on rod tip	See P. 243
Rod tip overhang distance	150mm or less
Ambient operating temp. & humidity	0~40°C, 85% RH or less (Non-condensing)

* Rod's angular displacement in rotational direction with no load applied to the rod.

RCP6(S)-RRA8R

Battery-less Absolute

Motor Unit Type

Side-mounted Motor

Body Width 85* mm

24v Stepper Motor

Model Specification Items

Series	Type	Encoder Type	Motor Type	Lead	Stroke	Applicable Controller/I/O Type	Cable Length	Options
RCP6: Separate Controller RCP6S: Built-in Controller	RRA8R	WA: Battery-less Absolute	60P: Stepper Motor 60□ Size	20: 20mm 10: 10mm 5: 5mm	50: 50mm 700: 700mm (50mm increments)	[RCP6] P4: PCON-CFB/CGFB [RCP6S] SE: SIO Type	N: None P: 1m S: 3m M: 5m X□□: Specified Length R□□: Robot Cable	Please refer to the options table below. *Please make sure to specify either ML or MR when ordering the side-mounted motor type.

* RCP6 does not include a controller. RCP6S includes a built-in controller.
* Please refer to P.16 for more information about the model specification items.

* Body width does not include the width of the side-mounted motor.

Radial Load OK

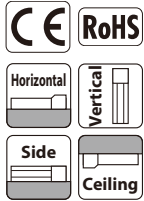

*Some limitations may apply to horizontal/side/ceiling mountings depending on the model. See page 204. Please contact IAI for more information.

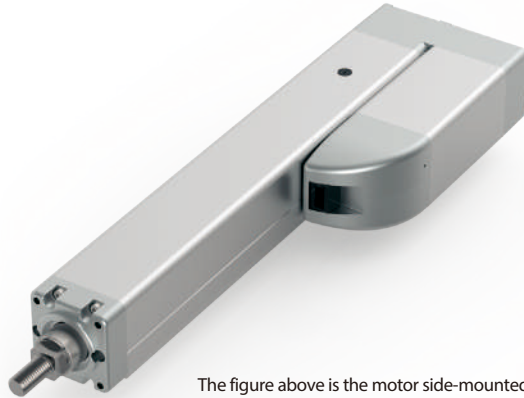

The figure above is the motor side-mounted to the left (ML).

	(1) The maximum acceleration/deceleration is 0.1G for lead 5 and 0.2G for lead 10/20.
	(2) The actuator specification displays the payload's maximum value, but it will vary depending on the acceleration and speed. Please refer to the "Selection Guidelines" (Tables of Payload by Speed/Acceleration) on P.217 for more details.
	(3) The radial cylinder is equipped with a built-in guide. Please refer to the graphs shown in P.243 and after for the allowable load mass.
	(4) Please refer to P205 for performing push-motion operation.
	(5) For RCP6S (built-in controller type), please limit the duty cycle to 70% or less.
	(6) The service life of an actuator varies depending on the payload when using vertically. Please refer to P. 206 for more information.

Correlation Diagrams of Speed and Payload

PCON connected.

RCP6(S)-RRA8R Horizontal mount

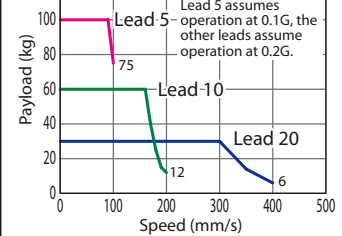

RCP6(S)-RRA8R Vertical mount

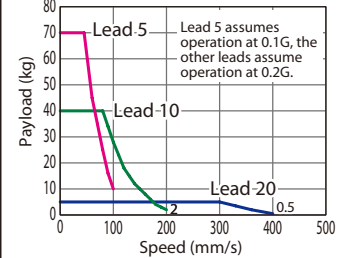

Actuator Specifications

Lead and Payload

* Horizontal external guide rail required for horizontal payload.
** Push force only available during push mode w / limited speed.

Model Number	Lead (mm)	Max. Payload		Max. Push Force (N)**	Stroke (mm)
		Horizontal (kg)*	Vertical (kg)		
RCP6(S)-RRA8R-WA-60P-20-①-②-③-④	20	30	5	500	50~700 (The increment of stroke is 50mm)
RCP6(S)-RRA8R-WA-60P-10-①-②-③-④	10	60	40	1,000	
RCP6(S)-RRA8R-WA-60P-5-①-②-③-④	5	100	70	2,000	

Legend: ① Stroke ② Applicable controller/I/O type ③ Cable length ④ Options

Stroke and Max. Speed

(Unit: mm/s)

Lead (mm)	50 (mm)	100~450 (mm)	500 (mm)	550 (mm)	600 (mm)	650 (mm)	700 (mm)
20	280	400	360	320	280	240	220
10	200	180	160	140	120	110	
5	100	90	80	70	60	55	

① Stroke

Stroke (mm)	RCP6	RCP6S	Stroke (mm)	RCP6	RCP6S
50	○	○	400	○	○
100	○	○	450	○	○
150	○	○	500	○	○
200	○	○	550	○	○
250	○	○	600	○	○
300	○	○	650	○	○
350	○	○	700	○	○

④ Options

Name	Option Code	Reference Page
Brake	B	See P.189
Cable exit direction (Outside)	CJO	See P.189
Flange	FL	See P.190
Tip adapter (Internal thread)	NFA	See P.193
Motor side-mounted to the left	ML	See P.193
Motor side-mounted to the right	MR	See P.193
Knuckle joint	NJ	See P.194
Non-motor end specification	NM	See P.194
Clevis bracket	QR	See P.195

* Be sure to confirm with the "Selection Notes (P.196)" when selecting options.
When selecting multiple options, please list them in alphabetical order. (e.g. B-CJB-NM)

③ Cable Length

Cable Type	Cable Code	RCP6	RCP6S
Standard	P (1m)	○	○
	S (3m)	○	○
	M (5m)	○	○
Specified Length	X06 (6m) ~X10 (10m)	○	○
	X11 (11m) ~X15 (15m)	○	○
	X16 (16m) ~X20 (20m)	○	○
	R01 (1m) ~R03 (3m)	○	○
Robot Cable	R04 (4m) ~R05 (5m)	○	○
	R06 (6m) ~R10 (10m)	○	○
	R11 (11m) ~R15 (15m)	○	○
	R16 (16m) ~R20 (20m)	○	○

* Please refer to P.267 and 283 for more information regarding the maintenance cables.

Actuator Specifications

Item	Description
Drive system	Ball screw ϕ 16mm, rolled C10
Positioning repeatability	\pm 0.01mm
Lost motion	0.1mm or less
Rod	ϕ 40mm Aluminum
Rod non-rotation precision*	0 deg.
Allowable load and torque on rod tip	See P. 243
Rod tip overhang distance	150mm or less
Ambient operating temp. & humidity	0~40°C, 85% RH or less (Non-condensing)

* Rod's angular displacement in rotational direction with no load applied to the rod.

CAD drawings can be downloaded from our website.
www.intelligentactuator.com



- *1 When the rod is returning to its home position, please be careful of interference from surrounding objects, as it will travel until it reaches the M.E. M.E: Mechanical end S.E: Stroke end
- *2 The direction of width across flats varies depending on the product.
- *3 When fixing the actuator using a front bracket or flange, please make sure that there is no external force applied to the main body.

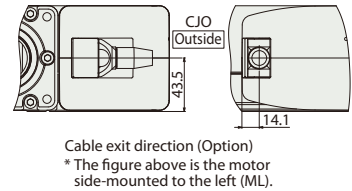
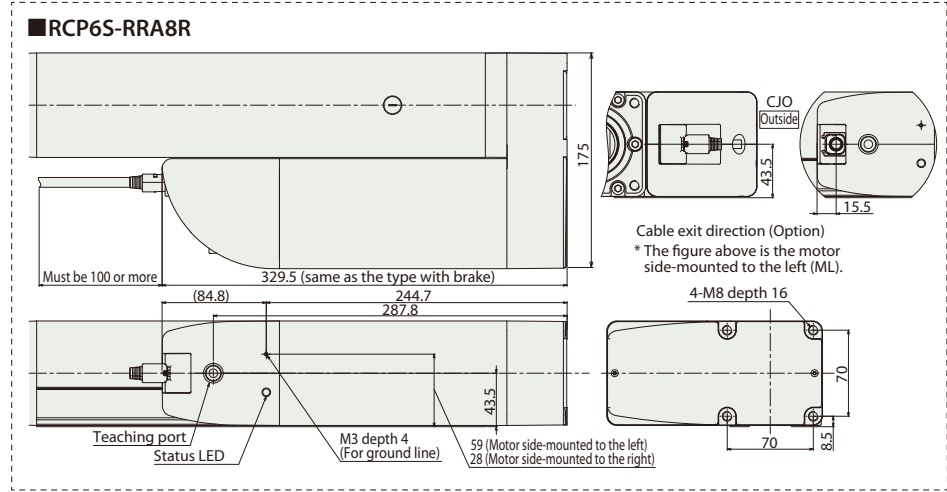
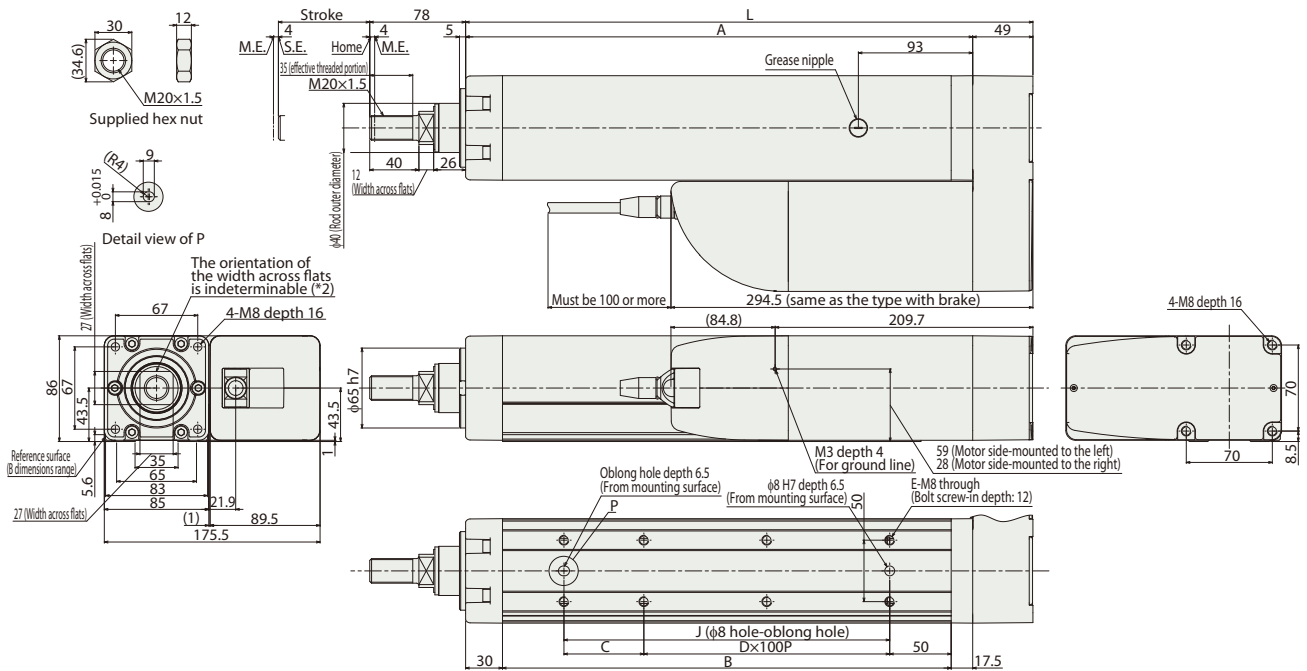

Rod Deflection of RCP6(S)-RRA8R (Reference Values)

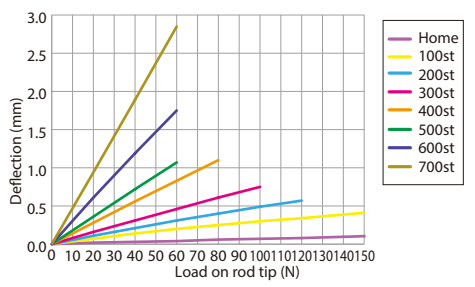

Dimensions and Mass by Stroke

Stroke	50	100	150	200	250	300	350	400	450	500	550	600	650	700	
L	311.5	361.5	411.5	461.5	511.5	561.5	611.5	661.5	711.5	761.5	811.5	861.5	911.5	961.5	
A	262.5	312.5	362.5	412.5	462.5	512.5	562.5	612.5	662.5	712.5	762.5	812.5	862.5	912.5	
B	215	265	315	365	415	465	515	565	615	665	715	765	815	865	
C	115	65	115	65	115	65	115	65	115	65	115	65	115	65	
D	0	1	1	2	2	3	3	4	4	5	5	6	6	7	
E	4	6	6	8	8	10	10	12	12	14	14	16	16	18	
J	115	165	215	265	315	365	415	465	515	565	615	665	715	765	
Allowable static load on rod tip (N)	222	186	159	139	124	111	101	92.1	84.7	78.4	72.8	68	63.7	59.8	
Allowable dynamic load on rod tip (5000km life) (N)	93.0	76.3	64.7	56.0	49.2	43.8	39.3	35.6	32.4	29.7	27.3	25.2	23.3	21.7	
Allowable static torque on rod tip (N·m)	22.3	18.7	16.1	14.1	12.6	11.3	10.3	9.4	8.7	8.1	7.6	7.1	6.7	6.3	
Allowable dynamic torque on rod tip (N·m)	7.2	6.2	5.4	4.8	4.3	3.9	3.5	3.2	3.0	2.7	2.5	2.4	2.2	2.0	
Mass (kg)	RCP6	w/o brake	7.9	8.3	8.8	9.3	9.8	10.2	10.7	11.2	11.7	12.1	12.6	13.1	13.6
		w/ brake	8.1	8.6	9.1	9.6	10.0	10.5	11.0	11.5	11.9	12.4	12.9	13.4	13.8
	RCP6S	w/o brake	8.1	8.5	9.0	9.5	10.0	10.4	10.9	11.4	11.9	12.3	12.8	13.3	13.8
		w/ brake	8.3	8.8	9.3	9.8	10.2	10.7	11.2	11.7	12.1	12.6	13.1	13.6	14.0

② Applicable Controllers

The RCP6 series actuators can be operated by the controllers indicated below. Please select the type depending on your intended use. * Please refer to P.271 for more information about the built-in controller of RCP6S series.

Name	External view	Max. number of controlled axes	Input power	Control method				Maximum number of positioning points	Reference page
				Positioner	Pulse train	Program	Network * Option		
PCON-CFB/CGFB		1	DC24V	● * Option	● * Option	—	DeviceNet CompoNet EtherNet/IP CC-Link MECHATROLINK EtherCAT CANopen	512 (768 for network spec.)	Please see P.255

Foreword
Slider Type
Slider Type
Wide Slider Type
Slider Type
Rod Type
Slider Type
Radial Cylinder
Wide Radial Cylinder
Table Type
Slider
Cleanroom Slider
Cleanroom Wide Slider
Dust/Splash-Proof Rod
Dust/Splash-Proof Radial Cylinder
Dust/Splash-Proof Wide Radial Cylinder
Options
Reference Data
Controller

RCP6(S)-WRA10C

Battery-less Absolute

Motor Unit Type

Coupled Motor

Body Width 100 mm

24v Stepper Motor

Model Specification Items

Series	Type	Encoder Type	Motor Type	Lead	Stroke	Applicable Controller/I/O Type	Cable Length	Options
□	— WRA10C —	WA	35P	□	□	□	□	□
RCP6: Separate Controller RCP6S: Built-in Controller		WA: Battery-less Absolute	35P: Stepper Motor 35□ Size	16: 16mm 10: 10mm 5: 5mm 2.5: 2.5mm	50: 50mm 500: 500mm (50mm increments)	[RCP6] P3: PCON MCON MSEL P5: RCM-P6PC [RCP6S] SE: SIO Type	N: None P: 1m S: 3m M: 5m □: Specified Length □: Robot Cable	Please refer to the options table below.

* RCP6 does not include a controller. RCP6S includes a built-in controller.
* Please refer to P.17 for more information about the model specification items.

Radial Load OK

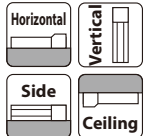

*Some limitations may apply to horizontal/side/ceiling mountings depending on the model. See page 204. Please contact IAI for more information.



- POINT Selection Notes**
- (1) The maximum acceleration/deceleration is 1G for horizontal, and 0.5G for vertical use.
 - (2) The actuator specification displays the payload's maximum value, but it will vary depending on the acceleration and speed. Please refer to the "Selection Guidelines" (Tables of Payload by Speed/Acceleration) on P.219 for more details.
 - (3) The radial cylinder is equipped with a built-in guide. Please refer to the graphs shown in P.246 and after for the allowable load mass.
 - (4) Please refer to P.205 for performing push-motion operation.

Correlation Diagrams of Speed and Payload

(1) High-output enabled with PCON/MCON/MSEL connected.

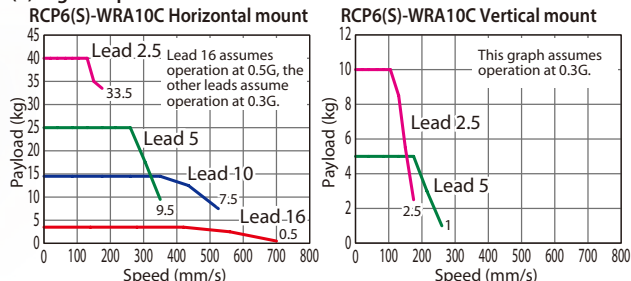

(2) High-output disabled with PCON/MCON connected.

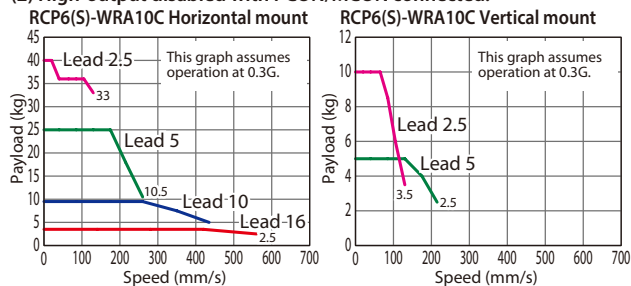

Actuator Specifications

Lead and Payload

* Horizontal external guide rail required for horizontal payload.
** Push force only available during push mode w / limited speed.

Model Number	Lead (mm)	Connected Controller	Max. Payload		Max. Push Force (N)**	Stroke (mm)
			Horizontal (kg)*	Vertical (kg)		
RCP6(S)-WRA10C-WA-35P-16-①-②-③-④	16	High-output Enabled	4	—	48	50~500 (The increment of stroke is 50mm)
		High-output Disabled	3.5	—		
RCP6(S)-WRA10C-WA-35P-10-①-②-③-④	10	High-output Enabled	14.5	—	77	
		High-output Disabled	9.5	—		
RCP6(S)-WRA10C-WA-35P-5-①-②-③-④	5	High-output Enabled	28	5	155	
		High-output Disabled	25	5		
RCP6(S)-WRA10C-WA-35P-2.5-①-②-③-④	2.5	High-output Enabled	40	10	310	
		High-output Disabled	40	10		

Legend: ① Stroke ② Applicable controller/I/O type ③ Cable length ④ Options

Stroke and Max. Speed

(Unit: mm/s)

Lead (mm)	Connected Controller	50~400 (Every 50mm)	450 (mm)	500 (mm)
16	High-output Enabled	700		
	High-output Disabled	560		
10	High-output Enabled	525	490	
	High-output Disabled	435		
5	High-output Enabled	350 <260>	290 <260>	240
	High-output Disabled	260 <215>		240
2.5	High-output Enabled	175	145	120
	High-output Disabled	130		120

Values in brackets < > are for vertical use.

① Stroke

Stroke (mm)	RCP6	RCP6S	Stroke (mm)	RCP6	RCP6S
50	○	○	300	○	○
100	○	○	350	○	○
150	○	○	400	○	○
200	○	○	450	○	○
250	○	○	500	○	○

④ Options

Name	Option Code	Reference Page
Brake	B	See P.189
Cable exit direction (Top)	CJT	See P.189
Cable exit direction (Right)	CJR	See P.189
Cable exit direction (Left) *	CJL	See P.189
Cable exit direction (Bottom)	CJB	See P.189
Flange	FL	See P.190
Non-motor end specification	NM	See P.194
T-slot nut bar (Left)	NTBL	See P.194
T-slot nut bar (Right)	NTBR	See P.194

* RCP6S cannot be selected.

When selecting multiple options, please list them in alphabetical order. (e.g. B-CJB-NM)

③ Cable Length

Cable Type	Cable Code	RCP6			RCP6S
		P3	P5	SE	
Standard	P (1m)	○	○	○	○
	S (3m)	○	○	○	○
	M (5m)	○	○	○	○
Specified Length	X06 (6m) ~ X10 (10m)	○	○	○	○
	X11 (11m) ~ X15 (15m)	○	○	○	○
	X16 (16m) ~ X20 (20m)	○	○	○	○
	R01 (1m) ~ R03 (3m)	○	○	○	○
Robot Cable	R04 (4m) ~ R05 (5m)	○	○	○	○
	R06 (6m) ~ R10 (10m)	○	○	○	○
	R11 (11m) ~ R15 (15m)	○	○	○	○
	R16 (16m) ~ R20 (20m)	○	○	○	○
		○	○	○	○

* Please refer to P.267 and 283 for more information regarding the maintenance cables.

Actuator Specifications

Item	Description
Drive system	Ball screw φ8mm, rolled C10
Positioning repeatability	±0.01mm
Lost motion	0.1mm or less
Rod	φ25mm Stainless steel
Rod non-rotation precision	0 deg.
Allowable load and torque on rod tip	See P.246
Rod tip overhang distance	100mm or less
Ambient operating temp. & humidity	0~40°C, 85% RH or less (Non-condensing)

CAD drawings can be downloaded from our website.
www.intelligentactuator.com



*1 When the rod is returning to its home position, please be careful of interference from surrounding objects, as it will travel until it reaches the M.E.
M.E: Mechanical end S.E: Stroke end
*2 If the object attached to the rod has a long overhang length, or precise angular adjustment of the object is required, please do not use the reamed hole when the object is attached to the rod.

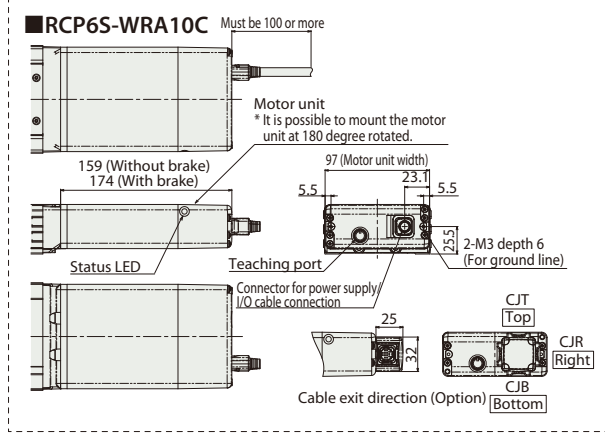
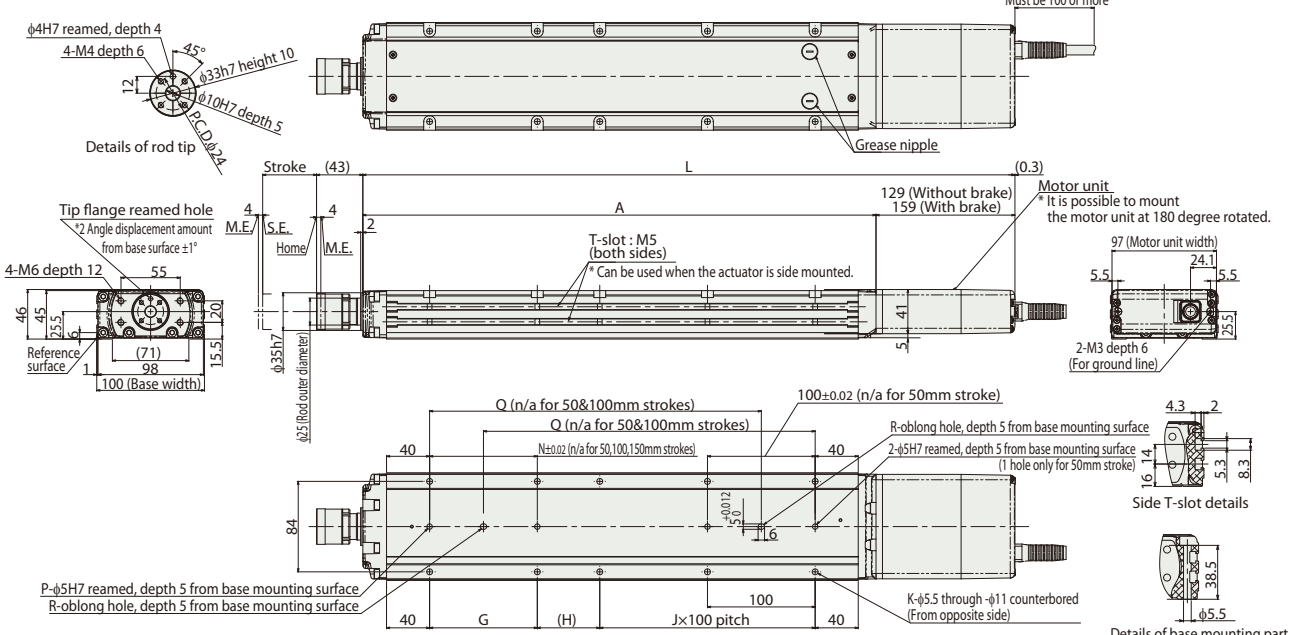

■ Dimensions and Mass by Stroke

Stroke		50	100	150	200	250	300	350	400	450	500
L	RCP6 w/o brake	355.5	405.5	455.5	505.5	555.5	605.5	655.5	705.5	755.5	805.5
	RCP6S w/o brake	385.5	435.5	485.5	535.5	585.5	635.5	685.5	735.5	785.5	835.5
L	RCP6 w/ brake	385.5	435.5	485.5	535.5	585.5	635.5	685.5	735.5	785.5	835.5
	RCP6S w/ brake	400.5	450.5	500.5	550.5	600.5	650.5	700.5	750.5	800.5	850.5
A		226.5	276.5	326.5	376.5	426.5	476.5	526.5	576.5	626.5	676.5
G		-	-	-	100	100	100	100	100	100	100
H		108	58	108	58	108	58	108	58	108	58
J		0	1	1	1	1	2	2	3	3	4
K		4	6	6	8	8	10	10	12	12	14
N		-	-	-	100	100	100	100	100	100	100
P		1	1	1	2	2	2	2	2	2	2
Q		-	-	158	208	258	308	358	408	458	508
R		0	0	1	1	1	1	1	1	1	1
Allowable static load on rod tip (N)		196	196	196	196	196	196	196	196	184	169
Allowable static torque on rod tip (N·m)		10	10	10	10	10	10	10	10	10	10
3,000km	Allowable dynamic load on rod tip (N)	98	98	98	95	85	76	68	62	57	52
	Allowable dynamic torque on rod tip (N·m)	5.0	5.0	5.0	5.0	5.0	5.0	5.0	5.0	5.0	4.9
5,000km	Allowable dynamic load on rod tip (N)	98	98	91	80	71	63	57	52	47	43
	Allowable dynamic torque on rod tip (N·m)	5.0	5.0	5.0	5.0	5.0	5.0	5.0	5.0	4.8	4.4
Mass (kg)	RCP6 w/o brake	3.3	3.8	4.2	4.7	5.1	5.6	6.0	6.5	6.9	7.4
	RCP6S w/o brake	3.5	4.0	4.4	4.9	5.3	5.8	6.2	6.7	7.1	7.6
Mass (kg)	RCP6 w/ brake	3.4	3.9	4.3	4.8	5.2	5.7	6.1	6.6	7.0	7.5
	RCP6S w/ brake	3.6	4.1	4.5	4.9	5.4	5.8	6.3	6.7	7.2	7.6

■ Rod Deflection of RCP6(S)-WRA10C (Reference Values)

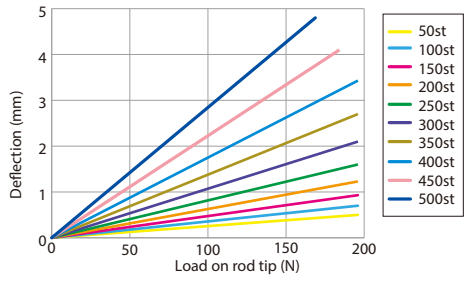

② Applicable Controllers

The RCP6 series actuators can be operated by the controllers indicated below. Please select the type depending on your intended use. * Please refer to P.271 for more information about the built-in controller of RCP6S series.

Name	External view	Max. number of controlled axes	Input power	Control method				Maximum number of positioning points	Reference page
				Positioner	Pulse train	Program	Network * Option		
PCON-CYB/PLB/POB		1	DC24V	●	●	-	Network cannot be selected	64	Please contact IAI for more information.
PCON-CB/CGB		1		* Option	* Option	-	DeviceNet MECHATROLINK CC-Link EtherCAT EtherNet/IP PROFINET CompoNet	512 (768 for network spec.)	Please see P.255
MCON-C/CG		8		This model is network-compatible only.				Note: The type of compatible networks will vary depending on the controller. Please refer to reference page for more information.	256
MCON-LC/LCG		6		-	-	●	256		Please contact IAI for more information.
MSEL-PC/PG		4	Single-phase 100 ~ 230 VAC	-	-	●	30,000	Please contact IAI for more information.	
RCM-P6PC		1	Usable within the RCP6S Gateway system.				768	Please see P.279	

* For the MCON controller, high-output enabled operation is only available if "high-output setting" is selected as an option. The maximum connectable axes with high-output enabled are C: 4 and LC: 3.

Foreword
Slider Type
Wide Slider Type
Rod Type
Radial Cylinder
Wide Radial Cylinder
Table Type
Cleanroom Slider
Cleanroom Wide Slider
Dust/Splash-Proof Rod
Dust/Splash-Proof Radial Cylinder
Dust/Splash-Proof Wide Radial Cylinder
Options
Reference Data
Controller

RCP6(S)-WRA12C

Battery-less Absolute

Motor Unit Type

Coupled Motor

Body Width 120 mm

24v Stepper Motor

Model Specification Items

Series	Type	Encoder Type	Motor Type	Lead	Stroke	Applicable Controller/I/O Type	Cable Length	Options
RCP6: Separate Controller RCP6S: Built-in Controller	WRA12C	WA: Battery-less Absolute	42P: Stepper Motor 42□ Size	20: 20mm 12: 12mm 6: 6mm 3: 3mm	50: 50mm 500: 500mm (50mm increments)	[RCP6] P3: PCON MCON MSEL P5: RCM-P6PC [RCP6S] SE: SIO Type	N: None P: 1m S: 3m M: 5m X□□: Specified Length R□□: Robot Cable	Please refer to the options table below.

* RCP6 does not include a controller. RCP6S includes a built-in controller.
* Please refer to P.17 for more information about the model specification items.

Radial Load OK

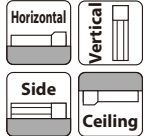

*Some limitations may apply to horizontal/side/ceiling mountings depending on the model. See page 204. Please contact IAI for more information.

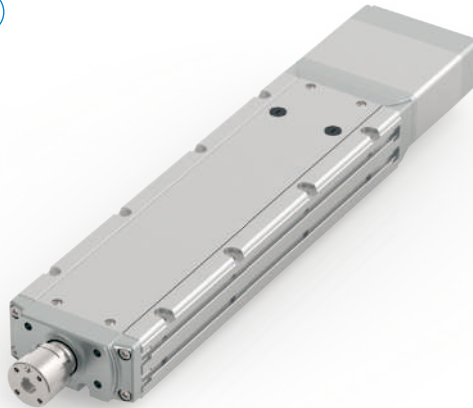

- POINT Selection Notes**
- (1) The maximum acceleration/deceleration is 1G for horizontal, and 0.5G for vertical use.
 - (2) The actuator specification displays the payload's maximum value, but it will vary depending on the acceleration and speed. Please refer to the "Selection Guidelines" (Tables of Payload by Speed/Acceleration) on P.219 for more details.
 - (3) The radial cylinder is equipped with a built-in guide. Please refer to the graphs shown in P.246 and after for the allowable load mass.
 - (4) Please refer to P.205 for performing push-motion operation.
 - (5) Depending on the ambient operational temperature, duty control is necessary for the RCP6S (built-in controller type) with lead 3/6. Please refer to P.247 for more information.

Correlation Diagrams of Speed and Payload

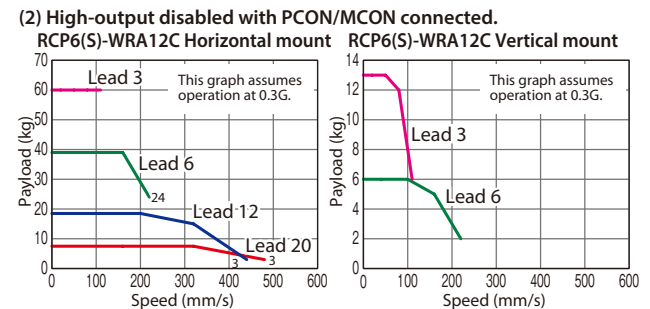
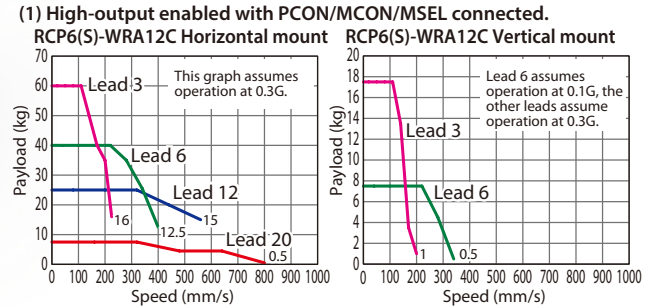

Actuator Specifications

Lead and Payload

Model Number	Lead (mm)	Connected Controller	Max. Payload		Max. Push Force (N)**	Stroke (mm)
			Horizontal (kg)*	Vertical (kg)		
RCP6(S)-WRA12C-WA-42P-20-①-②-③-④	20	High-output Enabled	7.5	-	56	50~500 (The increment of stroke is 50mm)
		High-output Disabled	7.5	-		
RCP6(S)-WRA12C-WA-42P-12-①-②-③-④	12	High-output Enabled	30	-	93	
		High-output Disabled	18.5	-		
RCP6(S)-WRA12C-WA-42P-6-①-②-③-④	6	High-output Enabled	55	7.5	185	
		High-output Disabled	39	6		
RCP6(S)-WRA12C-WA-42P-3-①-②-③-④	3	High-output Enabled	70	17.5	370	
		High-output Disabled	60	13		

Legend: ① Stroke ② Applicable controller/I/O type ③ Cable length ④ Options

Stroke and Max. Speed

Lead (mm)	Connected Controller	Max. Speed (Unit: mm/s)		
		50~400 (Every 50mm)	450 (mm)	500 (mm)
20	High-output Enabled	800		
	High-output Disabled	480		
12	High-output Enabled	560		
	High-output Disabled	440		
6	High-output Enabled	400 <340>		375 <340>
	High-output Disabled	220		
3	High-output Enabled	225 <200>	220 <200>	185
	High-output Disabled	110		

Values in brackets < > are for vertical use.

① Stroke

Stroke (mm)	RCP6	RCP6S	Stroke (mm)	RCP6	RCP6S
50	○	○	300	○	○
100	○	○	350	○	○
150	○	○	400	○	○
200	○	○	450	○	○
250	○	○	500	○	○

④ Options

Name	Option Code	Reference Page
Brake	B	See P.189
Cable exit direction (Top)	CJT	See P.189
Cable exit direction (Right)	CJR	See P.189
Cable exit direction (Left)	CJL	See P.189
Cable exit direction (Bottom)	CJB	See P.189
Flange	FL	See P.190
Non-motor end specification	NM	See P.194
T-slot nut bar (Left)	NTBL	See P.194
T-slot nut bar (Right)	NTBR	See P.194

When selecting multiple options, please list them in alphabetical order. (e.g. B-CJB-NM)

③ Cable Length

Cable Type	Cable Code	RCP6			RCP6S
		P3	P5	SE	
Standard	P (1m)	○	○	○	○
	S (3m)	○	○	○	○
	M (5m)	○	○	○	○
Specified Length	X06 (6m) ~X10 (10m)	○	○	○	○
	X11 (11m) ~X15 (15m)	○	○	○	○
	X16 (16m) ~X20 (20m)	○	○	○	○
	R01 (1m) ~R03 (3m)	○	○	○	○
Robot Cable	R04 (4m) ~R05 (5m)	○	○	○	○
	R06 (6m) ~R10 (10m)	○	○	○	○
	R11 (11m) ~R15 (15m)	○	○	○	○
	R16 (16m) ~R20 (20m)	○	○	○	○

* Please refer to P.267 and 283 for more information regarding the maintenance cables.

Actuator Specifications

Item	Description
Drive system	Ball screw φ10mm, rolled C10
Positioning repeatability	±0.01mm
Lost motion	0.1mm or less
Rod	φ30mm Stainless steel
Rod non-rotation precision	0 deg.
Allowable load and torque on rod tip	See P.246
Rod tip overhang distance	100mm or less
Ambient operating temp. & humidity	0~40°C, 85% RH or less (Non-condensing)

Dimensions

CAD drawings can be downloaded from our website.
www.intelligentactuator.com



*1 When the rod is returning to its home position, please be careful of interference from surrounding objects, as it will travel until it reaches the M.E.
M.E: Mechanical end S.E: Stroke end
*2 If the object attached to the rod has a long overhang length, or precise angular adjustment of the object is required, please do not use the reamed hole when the object is attached to the rod.

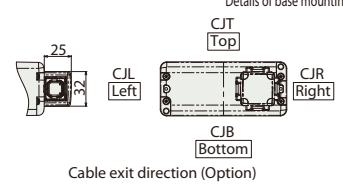
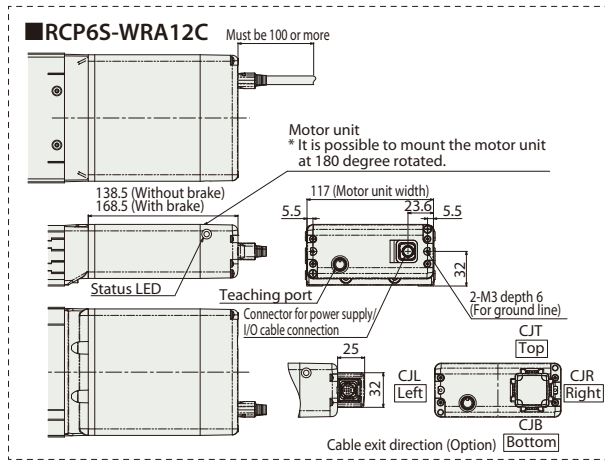
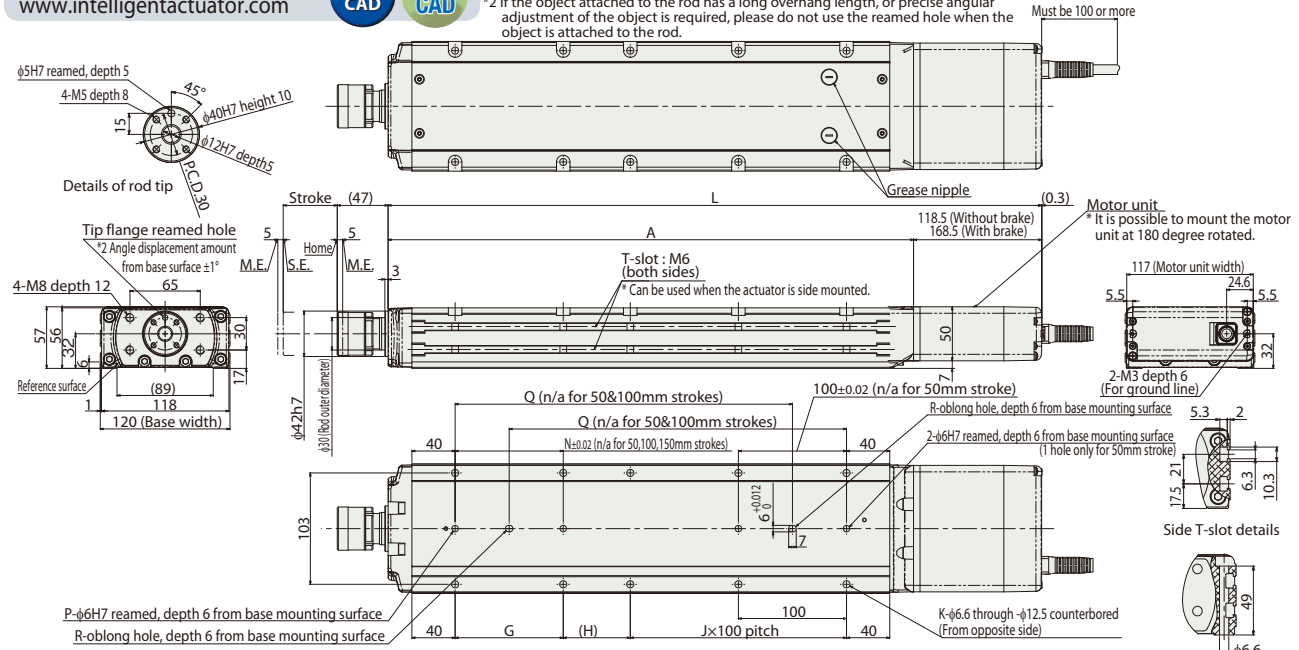

■ Dimensions and Mass by Stroke

Stroke		50	100	150	200	250	300	350	400	450	500
L	RCP6 w/o brake	354.5	404.5	454.5	504.5	554.5	604.5	654.5	704.5	754.5	804.5
	RCP6S w/o brake	404.5	454.5	504.5	554.5	604.5	654.5	704.5	754.5	804.5	854.5
L	RCP6 w/ brake	374.5	424.5	474.5	524.5	574.5	624.5	674.5	724.5	774.5	824.5
	RCP6S w/ brake	404.5	454.5	504.5	554.5	604.5	654.5	704.5	754.5	804.5	854.5
A		236	286	336	386	436	486	536	586	636	686
G		-	-	-	100	100	100	100	100	100	100
H		112	62	112	62	112	62	112	62	112	62
J		0	1	1	1	1	2	2	3	3	4
K		4	6	6	8	8	10	10	12	12	14
N		-	-	-	100	100	100	100	100	100	100
P		1	1	1	2	2	2	2	2	2	2
Q		-	-	162	212	262	312	362	412	462	512
R		0	0	1	1	1	1	1	1	1	1
Allowable static load on rod tip (N)		294	294	294	294	294	269	241	218	198	181
Allowable static torque on rod tip (N·m)		20	20	20	20	20	20	20	20	20	20
3,000km	Allowable dynamic load on rod tip (N)	147	147	137	121	107	96	87	79	72	65
	Load offset 0mm	100	100	100	100	99	90	82	75	68	63
	Allowable dynamic torque on rod tip (N·m)	10.0	10.0	10.0	10.0	9.9	9.0	8.2	7.5	6.8	6.3
5,000km	Allowable dynamic load on rod tip (N)	147	133	115	101	90	80	72	65	59	54
	Load offset 0mm	100	100	100	92	83	75	68	62	56	51
	Allowable dynamic torque on rod tip (N·m)	10.0	10.0	10.0	9.2	8.3	7.5	6.8	6.2	5.6	5.1
Mass (kg)	RCP6 w/o brake	4.7	5.3	6.0	6.6	7.3	7.9	8.5	9.2	9.8	10.5
	RCP6S w/o brake	5.0	5.6	6.3	6.9	7.6	8.2	8.8	9.5	10.1	10.8
Mass (kg)	RCP6 w/ brake	4.8	5.4	6.1	6.7	7.3	8.0	8.6	9.3	9.9	10.5
	RCP6S w/ brake	5.0	5.7	6.3	6.9	7.6	8.2	8.9	9.5	10.1	10.8

■ Rod Deflection of RCP6(S)-WRA12C (Reference Values)

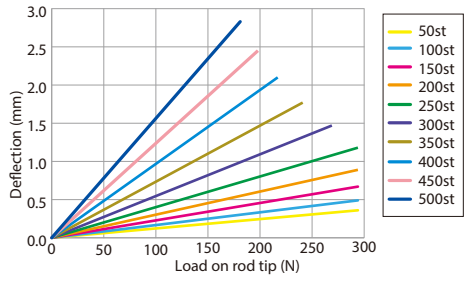

② Applicable Controllers

The RCP6 series actuators can be operated by the controllers indicated below. Please select the type depending on your intended use. * Please refer to P.271 for more information about the built-in controller of RCP6S series.

Name	External view	Max. number of controlled axes	Input power	Control method				Maximum number of positioning points	Reference page
				Positioner	Pulse train	Program	Network * Option		
PCON-CYB/PLB/POB		1	DC24V	●	●	-	Network cannot be selected	64	Please contact IAI for more information.
PCON-CB/CGB		1		* Option	* Option	-	DeviceNet MECHATROLINK CC-Link EtherCAT EtherNet/IP	512 (768 for network spec.)	Please see P.255
MCON-C/CG		8		This model is network-compatible only.				CompoNet SSCNET III/H	256
MCON-LC/LCG		6		-	-	●	256		Please contact IAI for more information.
MSEL-PC/PG		4	Single-phase 100 ~ 230 VAC	-	-	●	30,000	Please contact IAI for more information.	
RCM-P6PC		1	Usable within the RCP6S Gateway system.				768	Please see P.279	

* For the MCON controller, high-output enabled operation is only available if "high-output setting" is selected as an option. The maximum connectable axes with high-output enabled are C: 4 and LC: 3.

RCP6(S)-WRA14C

Battery-less Absolute

Motor Unit Type

Coupled Motor

Body Width 140 mm

24v Stepper Motor

Model Specification Items

Series	Type	Encoder Type	Motor Type	Lead	Stroke	Applicable Controller/I/O Type	Cable Length	Options
RCP6: Separate Controller RCP6S: Built-in Controller	WRA14C	WA: Battery-less Absolute	56P: Stepper Motor 56□ Size	24: 24mm 16: 16mm 8: 8mm 4: 4mm	50: 50mm 600: 600mm (50mm increments)	[RCP6] P3: PCON/MCON/MSEL P5: RCM-P6PC [RCP6S] SE: SIO Type	N: None P: 1m S: 3m M: 5m X□□: Specified Length R□□: Robot Cable	Please refer to the options table below.

* RCP6 does not include a controller. RCP6S includes a built-in controller.
* Please refer to P.17 for more information about the model specification items.

Radial Load OK

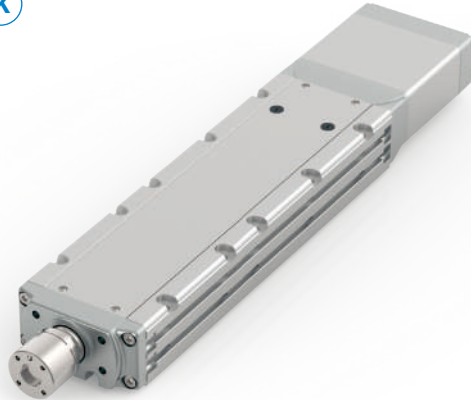
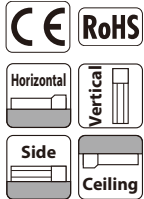

*Some limitations may apply to horizontal/side/ceiling mountings depending on the model. See page 204. Please contact IAI for more information.

- POINT Selection Notes**
- (1) The maximum acceleration/deceleration is 1G for horizontal, and 0.5G for vertical use.
 - (2) The actuator specification displays the payload's maximum value, but it will vary depending on the acceleration and speed. Please refer to the "Selection Guidelines" (Tables of Payload by Speed/Acceleration) on P.219 for more details.
 - (3) The radial cylinder is equipped with a built-in guide. Please refer to the graphs shown in P.246 and after for the allowable load mass.
 - (4) Please refer to P.205 for performing push-motion operation.
 - (5) Depending on the ambient operational temperature, duty control is necessary for the RCP6S (built-in controller type) with lead 4/8/16. Please refer to P.247 for more information.

Correlation Diagrams of Speed and Payload

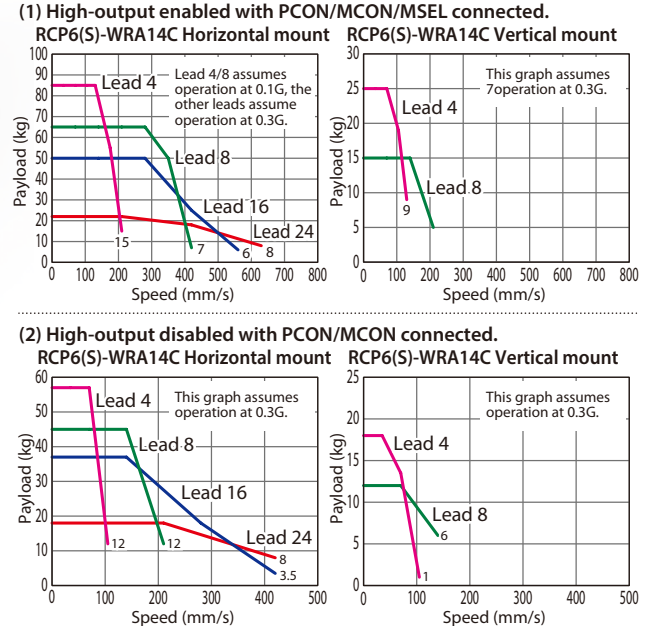

Actuator Specifications

Lead and Payload

* Horizontal external guide rail required for horizontal payload.
** Push force only available during push mode w / limited speed.

Model Number	Lead (mm)	Connected Controller	Max. Payload		Max. Push Force (N)**	Stroke (mm)
			Horizontal (kg)*	Vertical (kg)		
RCP6(S)-WRA14C-WA-56P-24-①-②-③-④	24	High-output Enabled	25	—	182	50~600 (The increment of stroke is 50mm)
		High-output Disabled	18	—		
RCP6(S)-WRA14C-WA-56P-16-①-②-③-④	16	High-output Enabled	50	—	273	
		High-output Disabled	37	—		
RCP6(S)-WRA14C-WA-56P-8-①-②-③-④	8	High-output Enabled	65	15	547	
		High-output Disabled	45	12		
RCP6(S)-WRA14C-WA-56P-4-①-②-③-④	4	High-output Enabled	85	25	1,094	
		High-output Disabled	57	18		

Legend: ① Stroke ② Applicable controller/I/O type ③ Cable length ④ Options

Stroke and Max. Speed

(Unit: mm/s)

Lead (mm)	Connected Controller	50~550 (Every 50mm)		600 (mm)
		50~550 (Every 50mm)	600 (mm)	
24	High-output Enabled	630		420
	High-output Disabled	420		
16	High-output Enabled	560		420
	High-output Disabled	420		
8	High-output Enabled	420 <210>	395 <210>	210 <140>
	High-output Disabled	210 <140>		
4	High-output Enabled	210 <130>	195 <130>	105
	High-output Disabled	105		

Values in brackets < > are for vertical use.

① Stroke

Stroke (mm)	RCP6	RCP6S	Stroke (mm)	RCP6	RCP6S
50	○	○	350	○	○
100	○	○	400	○	○
150	○	○	450	○	○
200	○	○	500	○	○
250	○	○	550	○	○
300	○	○	600	○	○

④ Options

Name	Option Code	Reference Page
Brake	B	See P.189
Cable exit direction (Top)	CJT	See P.189
Cable exit direction (Right)	CJR	See P.189
Cable exit direction (Left)	CJL	See P.189
Cable exit direction (Bottom)	CJB	See P.189
Flange	FL	See P.190
Non-motor end specification	NM	See P.194
T-slot nut bar (Left)	NTBL	See P.194
T-slot nut bar (Right)	NTBR	See P.194

When selecting multiple options, please list them in alphabetical order. (e.g. B-CJB-NM)

③ Cable Length

Cable Type	Cable Code	RCP6			RCP6S
		P3	P5	SE	
Standard	P (1m)	○	○	○	
	S (3m)	○	○	○	
	M (5m)	○	○	○	
	X06 (6m) ~X10 (10m)	○	○	○	
Specified Length	X11 (11m) ~X15 (15m)	○	○	○	
	X16 (16m) ~X20 (20m)	○	○	○	
	R01 (1m) ~R03 (3m)	○	○	○	
	R04 (4m) ~R05 (5m)	○	○	○	
Robot Cable	R06 (6m) ~R10 (10m)	○	○	○	
	R11 (11m) ~R15 (15m)	○	○	○	
	R16 (16m) ~R20 (20m)	○	○	○	

* Please refer to P.267 and 283 for more information regarding the maintenance cables.

Actuator Specifications

Item	Description
Drive system	Ball screw φ12mm, rolled C10
Positioning repeatability	±0.01mm
Lost motion	0.1mm or less
Rod	φ40mm Stainless steel
Rod non-rotation precision	0 deg.
Allowable load and torque on rod tip	See P. 246
Rod tip overhang distance	150mm or less
Ambient operating temp. & humidity	0~40°C, 85% RH or less (Non-condensing)

CAD drawings can be downloaded from our website.
www.intelligentactuator.com



*1 When the rod is returning to its home position, please be careful of interference from surrounding objects, as it will travel until it reaches the M.E.
M.E: Mechanical end S.E: Stroke end
*2 If the object attached to the rod has a long overhang length, or precise angular adjustment of the object is required, please do not use the reamed hole when the object is attached to the rod.

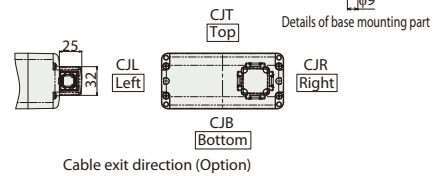
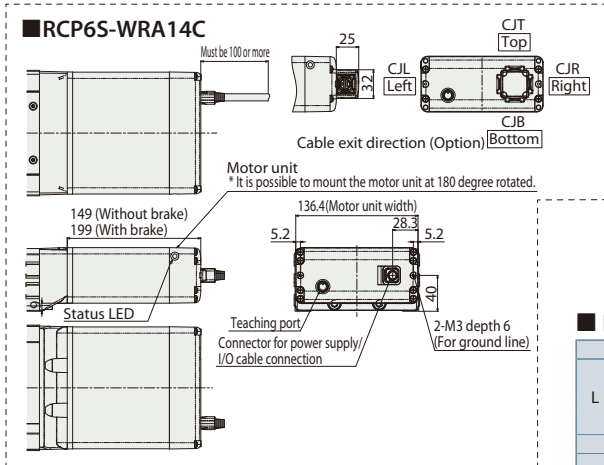
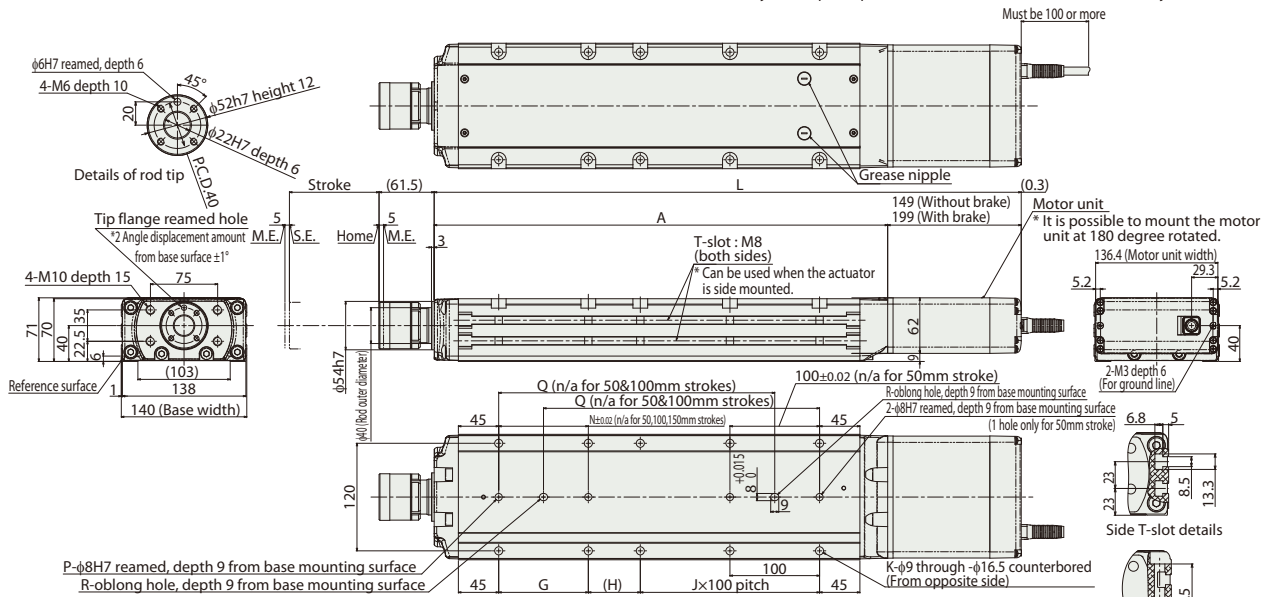

■ Dimensions and Mass by Stroke

Stroke		50	100	150	200	250	300	350	400	450	500	550	600	
L	RCP6	w/o brake	405	455	505	555	605	655	705	755	805	855	905	955
		w/ brake	455	505	555	605	655	705	755	805	855	905	955	1,005
	RCP6S	w/o brake	405	455	505	555	605	655	705	755	805	855	905	955
		w/ brake	455	505	555	605	655	705	755	805	855	905	955	1,005
A		256	306	356	406	456	506	556	606	656	706	756	806	
G		-	-	-	100	100	100	100	100	100	100	100	100	
H		108	58	108	58	108	58	108	58	108	58	108	58	
J		0	1	1	1	1	2	2	3	3	4	4	5	
K		4	6	6	8	8	10	10	12	12	14	14	16	
N		-	-	-	100	100	100	100	100	100	100	100	100	
P		1	1	1	2	2	2	2	2	2	2	2	2	
Q		-	-	158	208	258	308	358	408	458	508	558	608	
R		0	0	1	1	1	1	1	1	1	1	1	1	
Allowable static load on rod tip (N)		454	392	345	307	276	251	229	210	193	179	166	154	
Allowable static torque on rod tip (N·m)		30	30	30	30	30	30	30	30	30	30	30	30	
3,000km	Allowable dynamic load on rod tip (N)	Load offset 0mm	199	170	148	131	117	104	94	85	77	70	64	
		Load offset 150mm	100	100	100	100	100	95	87	79	72	66	60	
	Allowable dynamic torque on rod tip (N·m)	Load offset 0mm	15.0	15.0	15.0	15.0	15.0	14.3	13.0	11.8	10.8	9.9	9.0	
		Load offset 150mm	167	143	124	109	97	87	78	70	63	57	51	
5,000km	Allowable dynamic load on rod tip (N)	Load offset 0mm	100	100	100	96	87	79	71	65	59	53	48	
		Load offset 150mm	15.0	15.0	15.0	14.4	13.0	11.8	10.7	9.7	8.8	8.0	7.3	
	Allowable dynamic torque on rod tip (N·m)	w/o brake	8.0	8.9	9.8	10.6	11.5	12.4	13.3	14.2	15.0	15.9	16.8	
		w/ brake	8.5	9.4	10.2	11.1	12.0	12.9	13.8	14.6	15.5	16.4	17.3	
Mass (kg)	RCP6	w/o brake	8.0	8.9	9.8	10.7	11.6	12.4	13.3	14.2	15.1	16.0	16.8	
		w/ brake	8.5	9.4	10.3	11.2	12.0	12.9	13.8	14.7	15.6	16.4	17.3	
	RCP6S	w/o brake	8.0	8.9	9.8	10.7	11.6	12.4	13.3	14.2	15.1	16.0	16.8	
		w/ brake	8.5	9.4	10.3	11.2	12.0	12.9	13.8	14.7	15.6	16.4	17.3	

■ Rod Deflection of RCP6(S)-WRA14C (Reference Values)

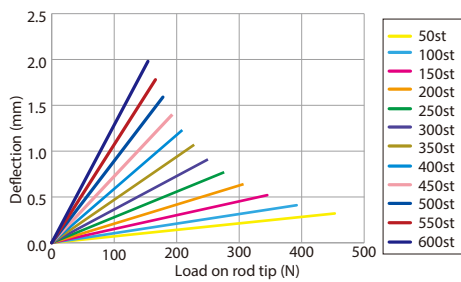

② Applicable Controllers

The RCP6 series actuators can be operated by the controllers indicated below. Please select the type depending on your intended use. * Please refer to P.271 for more information about the built-in controller of RCP6S series.

Name	External view	Max. number of controlled axes	Input power	Control method				Maximum number of positioning points	Reference page
				Positioner	Pulse train	Program	Network * Option		
PCON-CYB/PLB/POB		1	DC24V	●	●	-	Network cannot be selected	64	Please contact IAI for more information.
PCON-CB/CGB		1		* Option	* Option	-	DeviceNet MECHATROLINK CC-Link EtherCAT EtherNet/IP PROFINET CompoNet	512 (768 for network spec.)	Please see P.255
MCON-C/CG		8		This model is network-compatible only.					
MCON-LC/LCG		6		-	-	●	256	Please contact IAI for more information.	
MSEL-PC/PG		4	Single-phase 100 ~ 230 VAC	-	-	●	30,000	Please contact IAI for more information.	
RCM-P6PC		1	Usable within the RCP6S Gateway system.				768	Please see P.279	

Note:
* The type of compatible networks will vary depending on the controller. Please refer to reference page for more information.

* For the MCON controller, high-output enabled operation is only available if "high-output setting" is selected as an option. The maximum connectable axes with high-output enabled are C: 4 and LC: 3.

Foreword
Slider Type
Wide Slider Type
Rod Type
Radial Cylinder
Wide Radial Cylinder
Table Type
Cleanroom Slider
Cleanroom Wide Slider
Dust/Splash-Proof Rod
Dust/Splash-Proof Radial Cylinder
Dust/Splash-Proof Wide Radial Cylinder
Options
Reference Data
Controller

RCP6(S)-WRA16C

Battery-less Absolute Motor Unit Type Coupled Motor Body Width 160 mm 24v Stepper Motor

Model Specification Items	Series	Type	Encoder Type	Motor Type	Lead	Stroke	Applicable Controller/I/O Type	Cable Length	Options
	□	— WRA16C —	WA	60P	□	□	□	□	□
	RCP6: Separate Controller RCP6S: Built-in Controller		WA: Battery-less Absolute	60P: Stepper Motor 60□ Size	20: 20mm 10: 10mm 5: 5mm	50: 50mm 800: 800mm (50mm increments)	[RCP6] P4: PCON-CFB/CGFB [RCP6S] SE: SIO Type	N : None P : 1m S : 3m M : 5m X□□ : Specified Length R□□ : Robot Cable	Please refer to the options table below.

* RCP6 does not include a controller. RCP6S includes a built-in controller.
* Please refer to P.17 for more information about the model specification items.

Radial Load OK

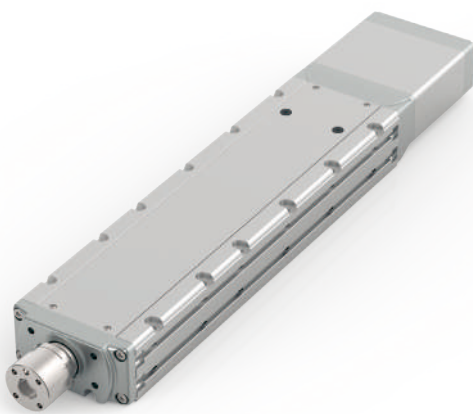
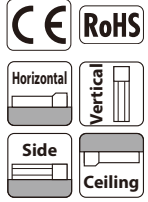

*Some limitations may apply to horizontal/side/ceiling mountings depending on the model. See page 204. Please contact IAI for more information.

- POINT Selection Notes**
- (1) The maximum acceleration/deceleration is 0.1G for lead 5 and 0.2G for lead 10/20.
 - (2) The actuator specification displays the payload's maximum value, but it will vary depending on the acceleration and speed. Please refer to the "Selection Guidelines" (Tables of Payload by Speed/Acceleration) on P.219 for more details.
 - (3) The radial cylinder is equipped with a built-in guide. Please refer to the graphs shown in P.246 and after for the allowable load mass.
 - (4) Please refer to P205 for performing push-motion operation.
 - (5) For RCP6S (built-in controller type), please limit the duty cycle to 70% or less.
 - (6) The service life of an actuator with lead 5 varies depending on the payload when using vertically. Please refer to P. 206 for more information.

Correlation Diagrams of Speed and Payload

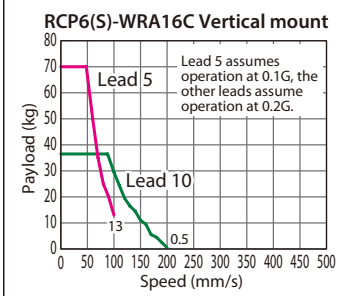
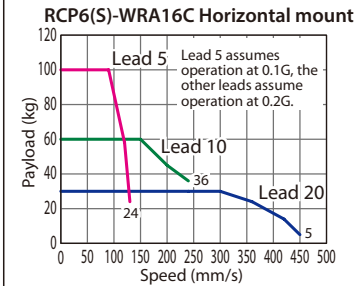

Actuator Specifications

Model Number	Lead (mm)	Max. Payload		Max. Push Force (N)**	Stroke (mm)
		Horizontal (kg)*	Vertical (kg)		
RCP6(S)-WRA16C-WA-60P-20-①-②-③-④	20	30	-	500	50~800 (The increment of stroke is 50mm)
RCP6(S)-WRA16C-WA-60P-10-①-②-③-④	10	60	36.5	1,000	
RCP6(S)-WRA16C-WA-60P-5-①-②-③-④	5	100	70	2,000	

Lead (mm)	Stroke (mm)										
	50	100	150~400	450	500	550	600	650	700	750	800
20	280	405	450	400	340	295	260	225	200	180	
10	240 <200>		230 <200>	195	165	145	125	110	100	90	
5	130 <100>		115 <100>	95	80	70	60	55	50	45	

Legend: ① Stroke ② Applicable controller/I/O type ③ Cable length ④ Options (Unit: mm/s) Values in brackets < > are for vertical use.

① Stroke

Stroke (mm)	RCP6	RCP6S	Stroke (mm)	RCP6	RCP6S
50	○	○	450	○	○
100	○	○	500	○	○
150	○	○	550	○	○
200	○	○	600	○	○
250	○	○	650	○	○
300	○	○	700	○	○
350	○	○	750	○	○
400	○	○	800	○	○

③ Cable Length

Cable Type	Cable Code	RCP6	RCP6S
Standard	P (1m)	○	○
	S (3m)	○	○
	M (5m)	○	○
Specified Length	X06 (6m) ~X10 (10m)	○	○
	X11 (11m) ~X15 (15m)	○	○
	X16 (16m) ~X20 (20m)	○	○
	R01 (1m) ~R03 (3m)	○	○
Robot Cable	R04 (4m) ~R05 (5m)	○	○
	R06 (6m) ~R10 (10m)	○	○
	R11 (11m) ~R15 (15m)	○	○
	R16 (16m) ~R20 (20m)	○	○

* Please refer to P.267 and 283 for more information regarding the maintenance cables.

④ Options

Name	Option Code	Reference Page
Brake	B	See P.189
Cable exit direction (Top)	CJT	See P.189
Cable exit direction (Right)	CJR	See P.189
Cable exit direction (Left)	CJL	See P.189
Cable exit direction (Bottom)	CJB	See P.189
Flange	FL	See P.190
Non-motor end specification	NM	See P.194
T-slot nut bar (Left)	NTBL	See P.194
T-slot nut bar (Right)	NTBR	See P.194

When selecting multiple options, please list them in alphabetical order. (e.g. B-CJB-NM)

Actuator Specifications

Item	Description
Drive system	Ball screw ϕ 16mm, rolled C10
Positioning repeatability	\pm 0.01mm
Lost motion	0.1mm or less
Rod	ϕ 45mm Stainless steel
Rod non-rotation precision	0 deg.
Allowable load and torque on rod tip	See P. 246
Rod tip overhang distance	150mm or less
Ambient operating temp. & humidity	0~40°C, 85% RH or less (Non-condensing)

CAD drawings can be downloaded from our website.
www.intelligentactuator.com



*1 When the rod is returning to its home position, please be careful of interference from surrounding objects, as it will travel until it reaches the M.E.
M.E: Mechanical end S.E: Stroke end
*2 If the object attached to the rod has a long overhang length, or precise angular adjustment of the object is required, please do not use the reamed hole when the object is attached to the rod.

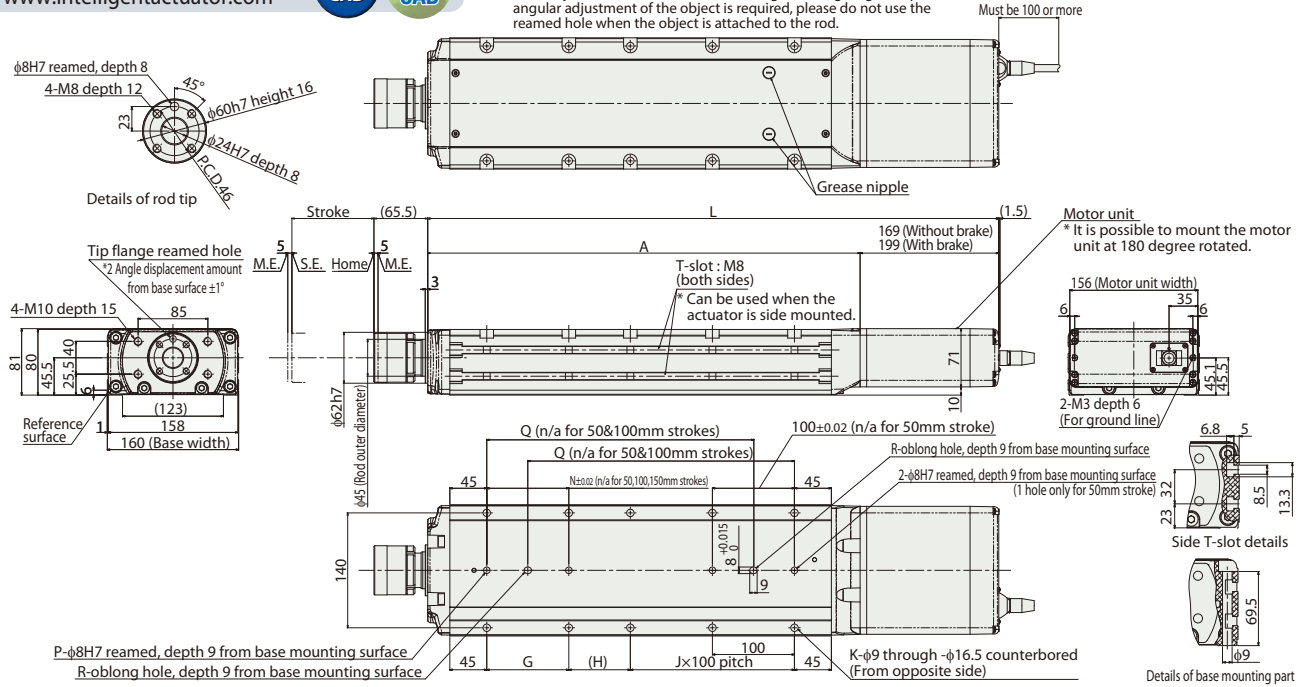

■ RCP6S-WRA16C

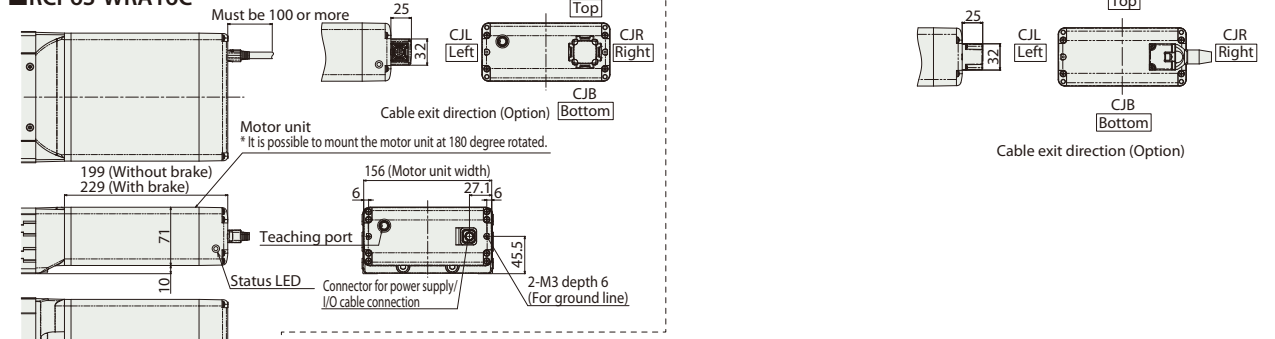

■ Rod Deflection of RCP6(S)-WRA16C (Reference Values)

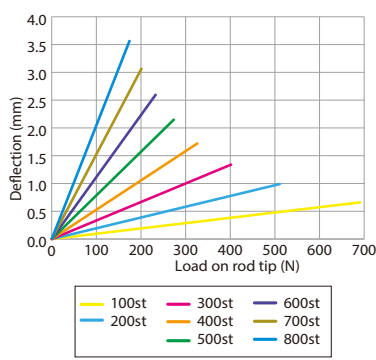

■ Dimensions and Mass by Stroke

Stroke	Stroke																	
	50	100	150	200	250	300	350	400	450	500	550	600	650	700	750	800		
L	RCP6	w/o brake	446	496	546	596	646	696	746	796	846	896	946	996	1,046	1,096	1,146	1,196
	w/ brake	476	526	576	626	676	726	776	826	876	926	976	1,026	1,076	1,126	1,176	1,226	
RCP6S	w/o brake	476	526	576	626	676	726	776	826	876	926	976	1,026	1,076	1,126	1,176	1,226	
	w/ brake	506	556	606	656	706	756	806	856	906	956	1,006	1,056	1,106	1,156	1,206	1,256	
A		277	327	377	427	477	527	577	627	677	727	777	827	877	927	977	1,027	
G		-	-	-	100	100	100	100	100	100	100	100	100	100	100	100	100	
H		125	75	125	75	125	75	125	75	125	75	125	75	125	75	125	75	
J		0	1	1	1	1	2	2	3	3	4	4	5	5	6	6	7	
K		4	6	6	8	8	10	10	12	12	14	14	16	16	18	18	20	
N		-	-	-	100	100	100	100	100	100	100	100	100	100	100	100	100	
P		1	1	1	2	2	2	2	2	2	2	2	2	2	2	2	2	
Q		-	-	175	225	275	325	375	425	475	525	575	625	675	725	775	825	
R		0	0	1	1	1	1	1	1	1	1	1	1	1	1	1	1	
Allowable static load on rod tip (N)		588	588	588	511	451	402	362	329	300	275	254	235	217	202	188	176	
	Allowable static torque on rod tip (N-m)	40	40	40	40	40	40	40	40	40	40	40	40	40	40	40	40	
3,000km	Allowable dynamic load on rod tip (N) Load offset 0mm	255	220	191	168	149	134	120	109	99	90	81	74	67	61	55	50	
	Allowable dynamic torque on rod tip (N-m) Load offset 150mm	133	133	133	133	133	122	111	101	92	84	77	70	64	58	53	48	
5,000km	Allowable dynamic load on rod tip (N) Load offset 0mm	214	184	160	140	124	111	99	89	80	72	65	59	53	47	42	37	
	Allowable dynamic torque on rod tip (N-m) Load offset 150mm	133	133	133	124	112	101	91	83	75	68	62	56	50	45	40	36	
Allowable dynamic torque on rod tip (N-m)		20.0	20.0	20.0	18.6	16.8	15.2	13.7	12.4	11.3	10.2	9.2	8.4	7.5	6.8	6.0	5.3	
	Mass (kg)	RCP6	w/o brake	11.5	12.6	13.7	14.9	16.0	17.1	18.3	19.4	20.5	21.7	22.8	23.9	25.1	26.2	27.3
	w/ brake	12.0	13.1	14.3	15.4	16.5	17.6	18.8	19.9	21.1	22.2	23.3	24.5	25.6	26.7	27.9	29.0	
	RCP6S	w/o brake	11.6	12.7	13.9	15.0	16.2	17.3	18.4	19.5	20.7	21.8	23.0	24.1	25.2	26.3	27.5	28.6
	w/ brake	12.1	13.3	14.4	15.5	16.7	17.8	18.9	20.1	21.2	22.3	23.5	24.6	25.8	26.9	28.0	29.1	

② Applicable Controllers

The RCP6 series actuators can be operated by the controllers indicated below. Please select the type depending on your intended use. * Please refer to P.271 for more information about the built-in controller of RCP6S series.

Name	External view	Max. number of controlled axes	Input power	Control method			Maximum number of positioning points	Reference page
				Positioner	Pulse train	Program		
PCON-CFB/CGFB		1	DC24V	Positioner	Pulse train	Program	512 (768 for network spec.)	Please see P.255
				* Option	* Option	-		
Control method								
Network * Option								

RCP6(S)-WRA10R

Battery-less Absolute Motor Unit Type Side-mounted Motor Body Width 100* mm 24v Stepper Motor

Model Specification Items	Series	Type	Encoder Type	Motor Type	Lead	Stroke	Applicable Controller/I/O Type	Cable Length	Options
	—	WRA10R	WA	35P	—	—	—	—	—
	RCP6: Separate Controller RCP6S: Built-in Controller		WA: Battery-less Absolute	35P: Stepper Motor 35□ Size	16: 16mm 10: 10mm 5: 5mm 2.5: 2.5mm	50: 50mm 500: 500mm (50mm increments)	[RCP6] P3: PCON MCON MSEL P5: RCM-P6PC [RCP6S] SE: SIO Type	N: None P: 1m S: 3m M: 5m □□□: Specified Length R□□: Robot Cable	Please refer to the options table below. *Please make sure to specify either ML or MR when ordering the side-mounted motor type.

* RCP6 does not include a controller. RCP6S includes a built-in controller.
* Please refer to P.17 for more information about the model specification items.

Radial Load OK



*Some limitations may apply to horizontal/side/ceiling mountings depending on the model. See page 204. Please contact IAI for more information.

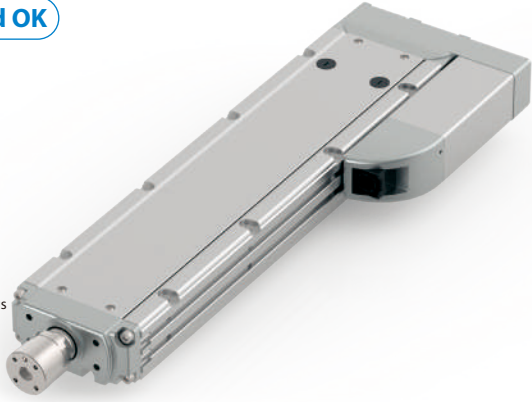

The figure above is the motor side-mounted to the left (ML).

- POINT Selection Notes**
- The maximum acceleration/deceleration is 1G for horizontal, and 0.5G for vertical use.
 - The actuator specification displays the payload's maximum value, but it will vary depending on the acceleration and speed. Please refer to the "Selection Guidelines" (Tables of Payload by Speed/Acceleration) on P.221 for more details.
 - The radial cylinder is equipped with a built-in guide. Please refer to the graphs shown in P.246 and after for the allowable load mass.
 - Please refer to P.205 for performing push-motion operation.

Correlation Diagrams of Speed and Payload

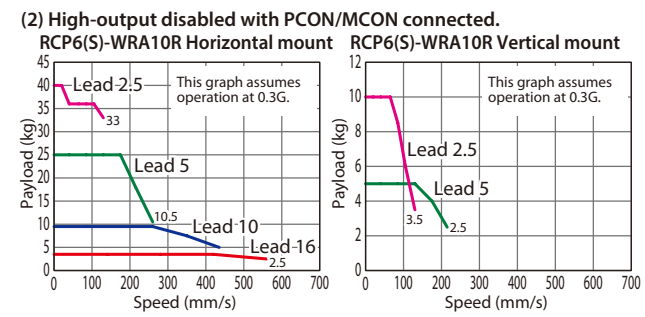
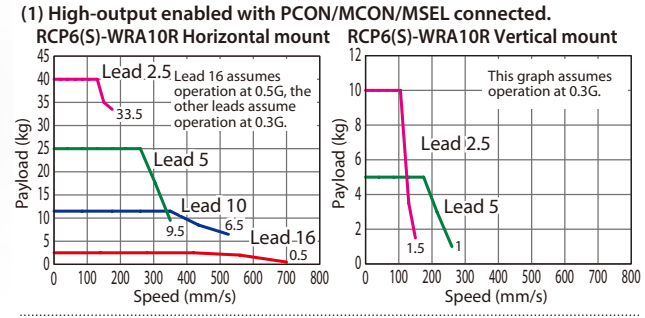

Actuator Specifications

Model Number	Lead (mm)	Connected Controller	Max. Payload		Max. Push Force (N)**	Stroke (mm)	Stroke and Max. Speed (Unit: mm/s)				
			Horizontal (kg)*	Vertical (kg)			Lead (mm)	Connected Controller	50~400 (Every 50mm)	450 (mm)	500 (mm)
RCP6(S)-WRA10R-WA-35P-16-①-②-③-④	16	High-output Enabled	4	—	48	50~500 (The increment of stroke is 50mm)	16	High-output Enabled	700		
		High-output Disabled	3.5	—				High-output Disabled	560		
RCP6(S)-WRA10R-WA-35P-10-①-②-③-④	10	High-output Enabled	11.5	—	77		10	High-output Enabled	525	490	
		High-output Disabled	9.5	—				High-output Disabled	435		
RCP6(S)-WRA10R-WA-35P-5-①-②-③-④	5	High-output Enabled	28	5	155		5	High-output Enabled	350 <260>	290 <260>	240
		High-output Disabled	25	5				High-output Disabled	260 <215> 240 <215>		
RCP6(S)-WRA10R-WA-35P-2.5-①-②-③-④	2.5	High-output Enabled	40	10	310		2.5	High-output Enabled	175 <150>	145	120
		High-output Disabled	40	10				High-output Disabled	130 120		

Legend: ① Stroke ② Applicable controller/I/O type ③ Cable length ④ Options

* Horizontal external guide rail required for horizontal payload. ** Push force only available during push mode w / limited speed. Values in brackets < > are for vertical use.

① Stroke

Stroke (mm)	RCP6	RCP6S	Stroke (mm)	RCP6	RCP6S
50	○	○	300	○	○
100	○	○	350	○	○
150	○	○	400	○	○
200	○	○	450	○	○
250	○	○	500	○	○

④ Options

Name	Option Code	Reference Page
Brake	B	See P.189
Cable exit direction (Outside)	CJO	See P.189
Flange	FL	See P.190
Motor side-mounted to the left	ML	See P.193
Motor side-mounted to the right	MR	See P.193
Non-motor end specification	NM	See P.194
T-slot nut bar (Left)	NTBL	See P.194
T-slot nut bar (Right)	NTBR	See P.194

* Be sure to confirm with the "Selection Notes (P.196)" when selecting options.
When selecting multiple options, please list them in alphabetical order. (e.g. B-CJB-NM)

③ Cable Length

Cable Type	Cable Code	RCP6			RCP6S
		P3	P5	SE	
Standard	P (1m)	○	○	○	○
	S (3m)	○	○	○	○
	M (5m)	○	○	○	○
	X06 (6m) ~X10 (10m)	○	○	○	○
Specified Length	X11 (11m) ~X15 (15m)	○	○	○	○
	X16 (16m) ~X20 (20m)	○	○	○	○
	R01 (1m) ~R03 (3m)	○	○	○	○
	R04 (4m) ~R05 (5m)	○	○	○	○
Robot Cable	R06 (6m) ~R10 (10m)	○	○	○	○
	R11 (11m) ~R15 (15m)	○	○	○	○
	R16 (16m) ~R20 (20m)	○	○	○	○

* Please refer to P.267 and 283 for more information regarding the maintenance cables.

Actuator Specifications

Item	Description
Drive system	Ball screw φ8mm, rolled C10
Positioning repeatability	±0.01mm
Lost motion	0.1mm or less
Rod	φ25mm Stainless steel
Rod non-rotation precision	0 deg.
Allowable load and torque on rod tip	See P. 246
Rod tip overhang distance	100mm or less
Ambient operating temp. & humidity	0~40°C, 85% RH or less (Non-condensing)

CAD drawings can be downloaded from our website.
www.intelligentactuator.com



*1 When the rod is returning to its home position, please be careful of interference from surrounding objects, as it will travel until it reaches the M.E.
M.E: Mechanical end S.E: Stroke end
*2 If the object attached to the rod has a long overhang length, or precise angular adjustment of the object is required, please do not use the reamed hole when the object is attached to the rod.

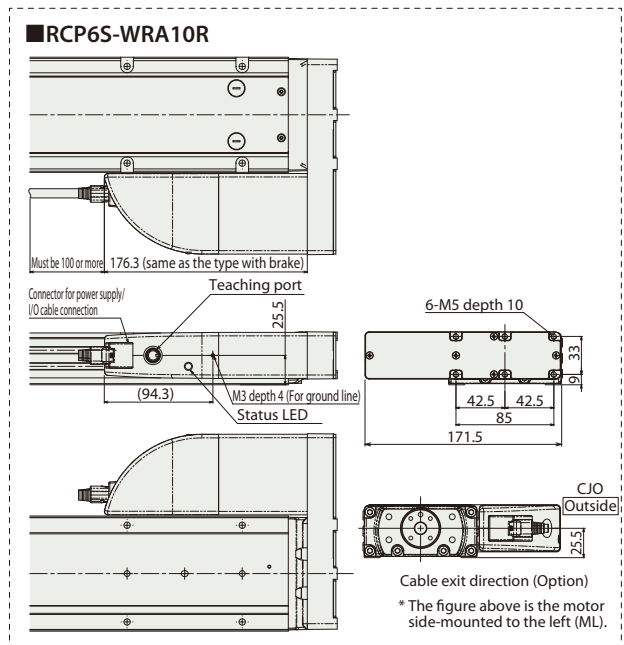
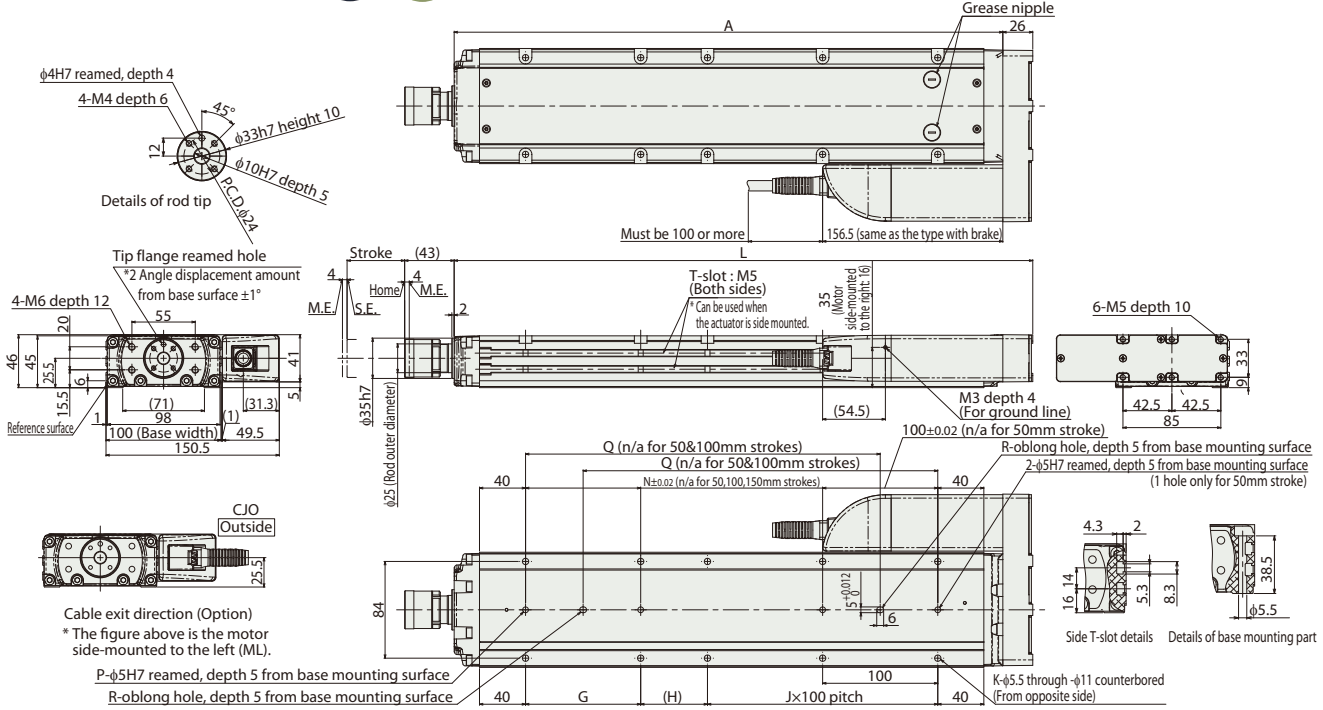

■ Rod Deflection of RCP6(S)-WRA10R (Reference Values)

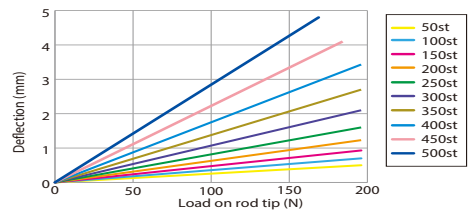

■ Dimensions and Mass by Stroke

Stroke	50	100	150	200	250	300	350	400	450	500	
L	252.5	302.5	352.5	402.5	452.5	502.5	552.5	602.5	652.5	702.5	
A	226.5	276.5	326.5	376.5	426.5	476.5	526.5	576.5	626.5	676.5	
G	-	-	-	100	100	100	100	100	100	100	
H	108	58	108	58	108	58	108	58	108	58	
J	0	1	1	1	1	2	2	3	3	4	
K	4	6	6	8	8	10	10	12	12	14	
N	-	-	-	100	100	100	100	100	100	100	
P	1	1	1	2	2	2	2	2	2	2	
Q	-	-	158	208	258	308	358	408	458	508	
R	0	0	1	1	1	1	1	1	1	1	
Allowable static load on rod tip (N)	196	196	196	196	196	196	196	196	184	169	
Allowable static torque on rod tip (N·m)	10	10	10	10	10	10	10	10	10	10	
3,000km	Allowable dynamic load on rod tip (N)	98	98	98	95	85	76	68	62	57	
	Load offset 0mm	50	50	50	50	50	50	50	50	49	
	Load offset 100mm	5.0	5.0	5.0	5.0	5.0	5.0	5.0	5.0	4.9	
5,000km	Allowable dynamic load on rod tip (N)	98	98	91	80	71	63	57	52	47	
	Load offset 0mm	50	50	50	50	50	50	48	44	40	
	Load offset 100mm	5.0	5.0	5.0	5.0	5.0	5.0	5.0	4.8	4.0	
Mass (kg)	RCP6	w/o brake	3.4	3.8	4.3	4.7	5.2	5.6	6.1	6.5	7.0
	w/ brake	3.5	3.9	4.4	4.8	5.3	5.7	6.1	6.6	7.0	
	RCP6S	w/o brake	3.5	4.0	4.4	4.9	5.3	5.8	6.2	6.6	7.1
	w/ brake	3.6	4.0	4.5	4.9	5.4	5.8	6.3	6.7	7.2	

② Applicable Controllers

The RCP6 series actuators can be operated by the controllers indicated below. Please select the type depending on your intended use. * Please refer to P.271 for more information about the built-in controller of RCP6S series.

Name	External view	Max. number of controlled axes	Input power	Control method				Maximum number of positioning points	Reference page
				Positioner	Pulse train	Program	Network * Option		
PCON-CYB/PLB/POB		1	DC24V	●	●	-	Network cannot be selected	64	Please contact IAI for more information.
PCON-CB/CGB		1		* Option	* Option	-	DeviceNet MECHATROLINK CC-Link EtherCAT EtherNet/IP CANopen CompoNet	512 (768 for network spec.)	Please see P.255
MCON-C/CG		8		This model is network-compatible only.					
MCON-LC/LCG		6		-	-	●	256	Please contact IAI for more information.	
MSEL-PC/PG		4	Single-phase 100 ~ 230 VAC	-	-	●	30,000	Please contact IAI for more information.	
RCM-P6PC		1	Usable within the RCP6S Gateway system.				768	Please see P.279	

* For the MCON controller, high-output enabled operation is only available if "high-output setting" is selected as an option. The maximum connectable axes with high-output enabled are C: 4 and LC: 3.

Foreword
Slider Type
Wide Slider Type
Rod Type
Radial Cylinder
Wide Radial Cylinder
Table Type
Cleanroom Slider
Cleanroom Wide Slider
Dust/Splash-Proof Rod
Dust/Splash-Proof Radial Cylinder
Dust/Splash-Proof Wide Radial Cylinder
Options
Reference Data
Controller

RCP6(S)-WRA12R

Battery-less Absolute

Motor Unit Type

Side-mounted Motor

Body Width 120mm*

24v Stepper Motor

Model Specification Items

Series	Type	Encoder Type	Motor Type	Lead	Stroke	Applicable Controller/I/O Type	Cable Length	Options
RCP6: Separate Controller RCP6S: Built-in Controller	WRA12R WA	WA Battery-less Absolute	42P Stepper Motor 42□ Size	20: 20mm 12: 12mm 6: 6mm 3: 3mm	50: 50mm 500: 500mm (50mm increments)	[RCP6] P3: PCON MCON MSEL P5: RCM-P6PC [RCP6S] SE: SIO Type	N: None P: 1m S: 3m M: 5m X□□: Specified Length R□□: Robot Cable	Please refer to the options table below. *Please make sure to specify either ML or MR when ordering the side-mounted motor type.

* Body width does not include the width of the side-mounted motor.

* RCP6 does not include a controller. RCP6S includes a built-in controller.
 * Please refer to P.17 for more information about the model specification items.

Radial Load OK

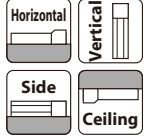

*Some limitations may apply to horizontal/side/ceiling mountings depending on the model. See page 204. Please contact IAI for more information.

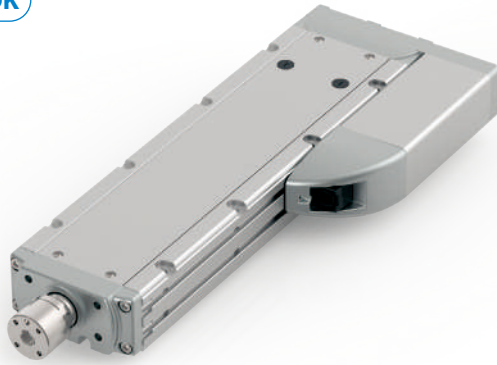

The figure above is the motor side-mounted to the left (ML).

	(1) The maximum acceleration/deceleration is 1G for horizontal, and 0.5G for vertical use.
	(2) The actuator specification displays the payload's maximum value, but it will vary depending on the acceleration and speed. Please refer to the "Selection Guidelines" (Tables of Payload by Speed/Acceleration) on P.221 for more details.
	(3) The radial cylinder is equipped with a built-in guide. Please refer to the graphs shown in P.246 and after for the allowable load mass.
	(4) Please refer to P205 for performing push-motion operation.
	(5) Depending on the ambient operational temperature, duty control is necessary for the RCP6S (built-in controller type) with lead 3/6. Please refer to P.247 for more information.

Correlation Diagrams of Speed and Payload

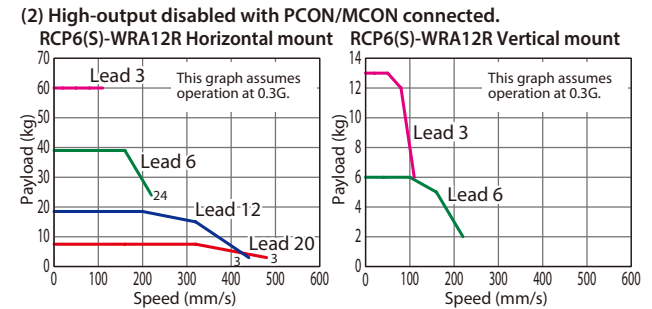
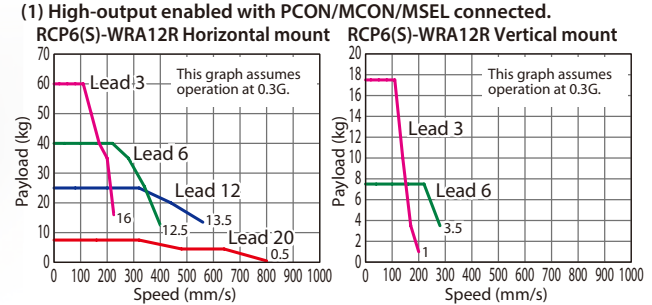

Actuator Specifications

Lead and Payload

* Horizontal external guide rail required for horizontal payload.
 ** Push force only available during push mode w / limited speed.

Model Number	Lead (mm)	Connected Controller	Max. Payload		Max. Push Force (N)**	Stroke (mm)
			Horizontal (kg)*	Vertical (kg)		
RCP6(S)-WRA12R-WA-42P-20-①-②-③-④	20	High-output Enabled	7.5	-	56	50~500 (The increment of stroke is 50mm)
		High-output Disabled	7.5	-		
RCP6(S)-WRA12R-WA-42P-12-①-②-③-④	12	High-output Enabled	30	-	93	
		High-output Disabled	18.5	-		
RCP6(S)-WRA12R-WA-42P-6-①-②-③-④	6	High-output Enabled	55	7.5	185	
		High-output Disabled	39	6		
RCP6(S)-WRA12R-WA-42P-3-①-②-③-④	3	High-output Enabled	70	17.5	370	
		High-output Disabled	60	13		

Legend: ① Stroke ② Applicable controller/I/O type ③ Cable length ④ Options

Stroke and Max. Speed

(Unit: mm/s)

Lead (mm)	Connected Controller	50~400 (Every 50mm)	450 (mm)	500 (mm)
20	High-output Enabled		800	
	High-output Disabled		480	
12	High-output Enabled		560	
	High-output Disabled		440	
6	High-output Enabled	400 <280>		375 <280>
	High-output Disabled		220	
3	High-output Enabled	225 <200>	220 <200>	185
	High-output Disabled		110	

Values in brackets < > are for vertical use.

① Stroke

Stroke (mm)	RCP6	RCP6S	Stroke (mm)	RCP6	RCP6S
50	○	○	300	○	○
100	○	○	350	○	○
150	○	○	400	○	○
200	○	○	450	○	○
250	○	○	500	○	○

④ Options

Name	Option Code	Reference Page
Brake	B	See P.189
Cable exit direction (Outside)	CJO	See P.189
Flange	FL	See P.190
Motor side-mounted to the left	ML	See P.193
Motor side-mounted to the right	MR	See P.193
Non-motor end specification	NM	See P.194
T-slot nut bar (Left)	NTBL	See P.194
T-slot nut bar (Right)	NTBR	See P.194

* Be sure to confirm with the "Selection Notes (P.196)" when selecting options.
 # When selecting multiple options, please list them in alphabetical order. (e.g. B-CJB-NM)

③ Cable Length

Cable Type	Cable Code	RCP6			RCP6S
		P3	P5	SE	
Standard	P (1m)	○	○	○	○
	S (3m)	○	○	○	○
	M (5m)	○	○	○	○
Specified Length	X06 (6m) ~X10 (10m)	○	○	○	○
	X11 (11m) ~X15 (15m)	○	○	○	○
	X16 (16m) ~X20 (20m)	○	○	○	○
	R01 (1m) ~R03 (3m)	○	○	○	○
Robot Cable	R04 (4m) ~R05 (5m)	○	○	○	○
	R06 (6m) ~R10 (10m)	○	○	○	○
	R11 (11m) ~R15 (15m)	○	○	○	○
	R16 (16m) ~R20 (20m)	○	○	○	○
		○	○	○	○

* Please refer to P.267 and 283 for more information regarding the maintenance cables.

Actuator Specifications

Item	Description
Drive system	Ball screw φ10mm, rolled C10
Positioning repeatability	±0.01mm
Lost motion	0.1mm or less
Rod	φ30mm Stainless steel
Rod non-rotation precision	0 deg.
Allowable load and torque on rod tip	See P.246
Rod tip overhang distance	100mm or less
Ambient operating temp. & humidity	0~40°C, 85% RH or less (Non-condensing)

CAD drawings can be downloaded from our website.
www.intelligentactuator.com



- *1 When the rod is returning to its home position, please be careful of interference from surrounding objects, as it will travel until it reaches the M.E.
- M.E: Mechanical end S.E: Stroke end
- *2 If the object attached to the rod has a long overhang length, or precise angular adjustment of the object is required, do not use the reamed hole when the object is attached to the rod.

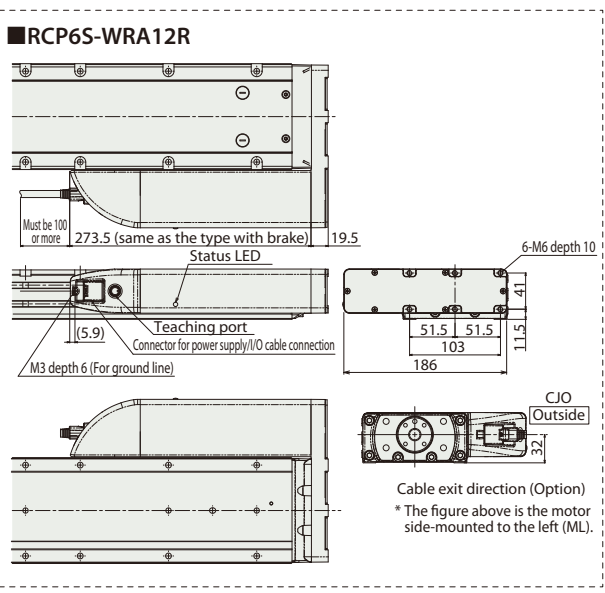
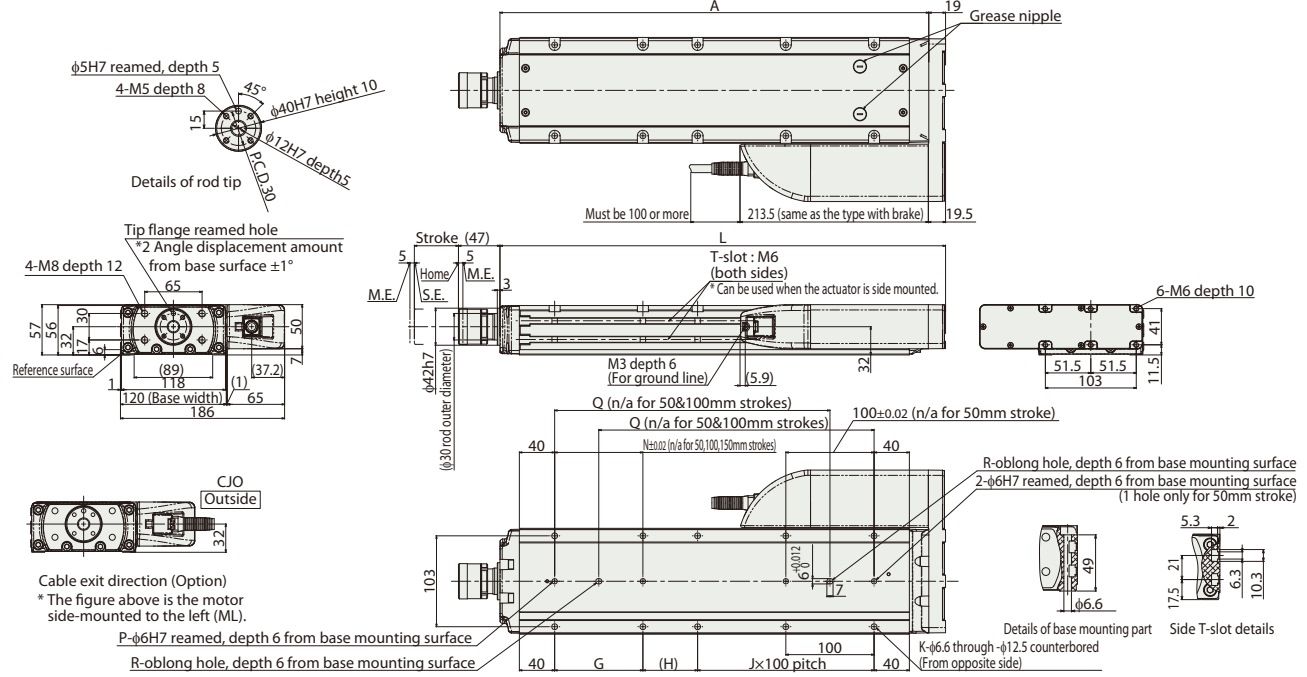

■ Rod Deflection of RCP6(S)-WRA12R (Reference Values)

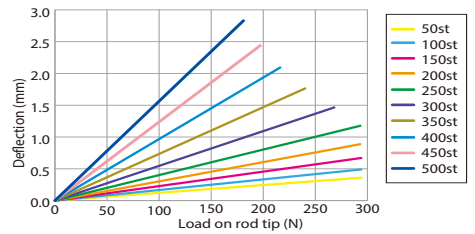

■ Dimensions and Mass by Stroke

Stroke	50	100	150	200	250	300	350	400	450	500
L	255	305	355	405	455	505	555	605	655	705
A	236	286	336	386	436	486	536	586	636	686
G	-	-	-	100	100	100	100	100	100	100
H	112	62	112	62	112	62	112	62	112	62
J	0	1	1	1	1	2	2	3	3	4
K	4	6	6	8	8	10	10	12	12	14
N	-	-	-	100	100	100	100	100	100	100
P	1	1	1	2	2	2	2	2	2	2
Q	-	-	162	212	262	312	362	412	462	512
R	0	0	1	1	1	1	1	1	1	1
Allowable static torque on rod tip (N)	294	294	294	294	294	269	241	218	198	181
Allowable static torque on rod tip (N·m)	20	20	20	20	20	20	20	20	20	20
3,000km	Allowable dynamic load on rod tip (N)	147	147	137	121	107	96	87	79	72
	Load offset 0mm	100	100	100	100	99	90	82	75	68
	Load offset 100mm	100	100	100	100	99	90	82	75	68
5,000km	Allowable dynamic load on rod tip (N)	147	133	115	101	90	80	72	65	59
	Load offset 0mm	100	100	100	92	83	75	68	62	56
	Load offset 100mm	100	100	100	92	83	75	68	62	56
Mass (kg)	RCP6 w/o brake	5.1	5.7	6.3	7.0	7.6	8.2	8.9	9.5	10.2
	RCP6 w/ brake	5.1	5.8	6.4	7.0	7.7	8.3	9.0	9.6	10.2
	RCP6S w/o brake	5.2	5.8	6.5	7.1	7.7	8.4	9.0	9.6	10.3
	RCP6S w/ brake	5.3	5.9	6.5	7.2	7.8	8.4	9.1	9.7	10.4

② Applicable Controllers

The RCP6 series actuators can be operated by the controllers indicated below. Please select the type depending on your intended use. * Please refer to P.271 for more information about the built-in controller of RCP6S series.

Name	External view	Max. number of controlled axes	Input power	Control method				Maximum number of positioning points	Reference page
				Positioner	Pulse train	Program	Network * Option		
PCON-CYB/PLB/POB		1	DC24V	●	●	-	Network cannot be selected	64	Please contact IAI for more information.
PCON-CB/CGB		1		* Option	* Option	-	DeviceNet MECHATROLINK CC-Link EtherCAT EtherNet/IP CANopen CompoNet	512 (768 for network spec.)	Please see P.255
MCON-C/CG		8		This model is network-compatible only.					
MCON-LC/LCG		6		-	-	●	256	Please contact IAI for more information.	
MSEL-PC/PG		4	Single-phase 100 ~ 230 VAC	-	-	●	30,000	Please contact IAI for more information.	
RCM-P6PC		1	Usable within the RCP6S Gateway system.				768	Please see P.279	

* For the MCON controller, high-output enabled operation is only available if "high-output setting" is selected as an option. The maximum connectable axes with high-output enabled are C: 4 and LC: 3.

Foreword
Slider Type
Wide Slider Type
Rod Type
Radial Cylinder
Wide Radial Cylinder
Table Type
Cleanroom Slider
Cleanroom Wide Slider
Dust/Splash-Proof Rod
Dust/Splash-Proof Radial Cylinder
Dust/Splash-Proof Wide Radial Cylinder
Options
Reference Data
Controller

RCP6(S)-WRA14R

Battery-less Absolute

Motor Unit Type

Side-mounted Motor

Body Width 140* mm

24v Stepper Motor

Model Specification Items

Series — Type — Encoder Type — Motor Type — Lead — Stroke — Applicable Controller/I/O Type — Cable Length — Options

RCP6: Separate Controller
RCP6S: Built-in Controller

WA: Battery-less Absolute

56P: Stepper Motor
56□ Size

24: 24mm
16: 16mm
8: 8mm
4: 4mm

[RCP6]
P3: PCON
MCON
MSEL
P5: RCM-P6PC
[RCP6S]
SE: SIO Type

N: None
P: 1m
S: 3m
M: 5m
□□□: Specified Length
R□□: Robot Cable

Please refer to the options table below.
*Please make sure to specify either ML or MR when ordering the side-mounted motor type.

* Body width does not include the width of the side-mounted motor.

* RCP6 does not include a controller. RCP6S includes a built-in controller.
* Please refer to P.17 for more information about the model specification items.

Radial Load OK

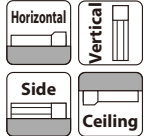

*Some limitations may apply to horizontal/side/ceiling mountings depending on the model. See page 204. Please contact IAI for more information.

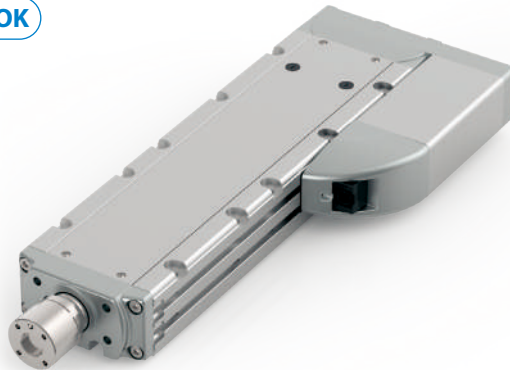

The figure above is the motor side-mounted to the left (ML).

POINT Selection Notes

- (1) The maximum acceleration/deceleration is 1G for horizontal, and 0.5G for vertical use.
- (2) The actuator specification displays the payload's maximum value, but it will vary depending on the acceleration and speed. Please refer to the "Selection Guidelines" (Tables of Payload by Speed/Acceleration) on P.221 for more details.
- (3) The radial cylinder is equipped with a built-in guide. Please refer to the graphs shown in P.246 and after for the allowable load mass.
- (4) Please refer to P.205 for performing push-motion operation.
- (5) Depending on the ambient operational temperature, duty control is necessary for the RCP6S (built-in controller type) with lead 4/8/16. Please refer to P.247 for more information.

Correlation Diagrams of Speed and Payload

(1) High-output enabled with PCON/MCON/MSEL connected.

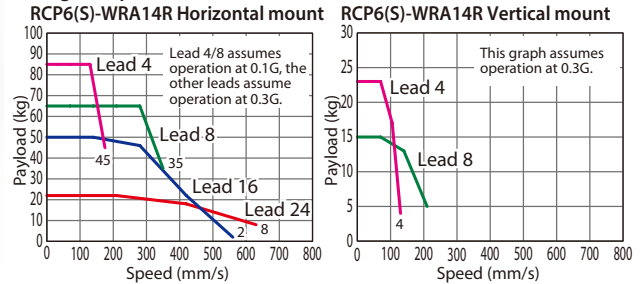

(2) High-output disabled with PCON/MCON connected.

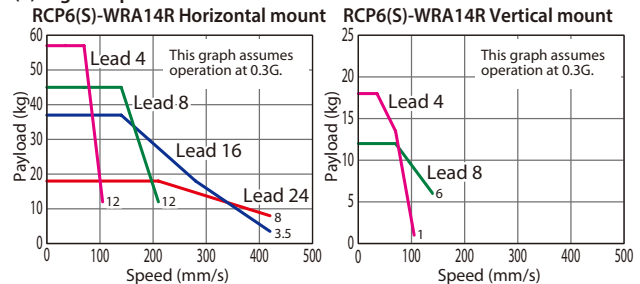

Actuator Specifications

Lead and Payload

* Horizontal external guide rail required for horizontal payload.
** Push force only available during push mode w / limited speed.

Model Number	Lead (mm)	Connected Controller	Max. Payload		Max. Push Force (N)**	Stroke (mm)
			Horizontal (kg)*	Vertical (kg)		
RCP6(S)-WRA14R-WA-56P-24-①-②-③-④	24	High-output Enabled	25	—	182	50~600 (The increment of stroke is 50mm)
		High-output Disabled	18	—		
RCP6(S)-WRA14R-WA-56P-16-①-②-③-④	16	High-output Enabled	50	—	273	
		High-output Disabled	37	—		
RCP6(S)-WRA14R-WA-56P-8-①-②-③-④	8	High-output Enabled	65	15	547	
		High-output Disabled	45	12		
RCP6(S)-WRA14R-WA-56P-4-①-②-③-④	4	High-output Enabled	85	25	1,094	
		High-output Disabled	57	18		

Legend: ① Stroke ② Applicable controller/I/O type ③ Cable length ④ Options

Stroke and Max. Speed

(Unit: mm/s)

Lead (mm)	Connected Controller	50~600 (Every 50mm)
24	High-output Enabled	630
	High-output Disabled	420
16	High-output Enabled	560
	High-output Disabled	420
8	High-output Enabled	350 <210>
	High-output Disabled	210 <140>
4	High-output Enabled	175 <130>
	High-output Disabled	105

Values in brackets < > are for vertical use.

① Stroke

Stroke (mm)	RCP6	RCP6S	Stroke (mm)	RCP6	RCP6S
50	○	○	350	○	○
100	○	○	400	○	○
150	○	○	450	○	○
200	○	○	500	○	○
250	○	○	550	○	○
300	○	○	600	○	○

④ Options

Name	Option Code	Reference Page
Brake	B	See P.189
Cable exit direction (Outside)	CJO	See P.189
Flange	FL	See P.190
Motor side-mounted to the left	ML	See P.193
Motor side-mounted to the right	MR	See P.193
Non-motor end specification	NM	See P.194
T-slot nut bar (Left)	NTBL	See P.194
T-slot nut bar (Right)	NTBR	See P.194

* Be sure to confirm with the "Selection Notes (P.196)" when selecting options.
When selecting multiple options, please list them in alphabetical order. (e.g. B-CJB-NM)

③ Cable Length

Cable Type	Cable Code	RCP6		RCP6S
		P3	P5	SE
Standard	P (1m)	○	○	○
	S (3m)	○	○	○
	M (5m)	○	○	○
Specified Length	X06 (6m) ~X10 (10m)	○	○	○
	X11 (11m) ~X15 (15m)	○	○	○
	X16 (16m) ~X20 (20m)	○	○	○
	R01 (1m) ~R03 (3m)	○	○	○
Robot Cable	R04 (4m) ~R05 (5m)	○	○	○
	R06 (6m) ~R10 (10m)	○	○	○
	R11 (11m) ~R15 (15m)	○	○	○
	R16 (16m) ~R20 (20m)	○	○	○

* Please refer to P.267 and 283 for more information regarding the maintenance cables.

Actuator Specifications

Item	Description
Drive system	Ball screw φ12mm, rolled C10
Positioning repeatability	±0.01mm
Lost motion	0.1mm or less
Rod	φ40mm Stainless steel
Rod non-rotation precision	0 deg.
Allowable load and torque on rod tip	See P.246
Rod tip overhang distance	150mm or less
Ambient operating temp. & humidity	0~40°C, 85% RH or less (Non-condensing)

CAD drawings can be downloaded from our website.
www.intelligentactuator.com



- *1 When the rod is returning to its home position, please be careful of interference from surrounding objects, as it will travel until it reaches the M.E.
- M.E: Mechanical end S.E: Stroke end
- *2 If the object attached to the rod has a long overhang length, or precise angular adjustment of the object is required, please do not use the reamed hole when the object is attached to the rod.

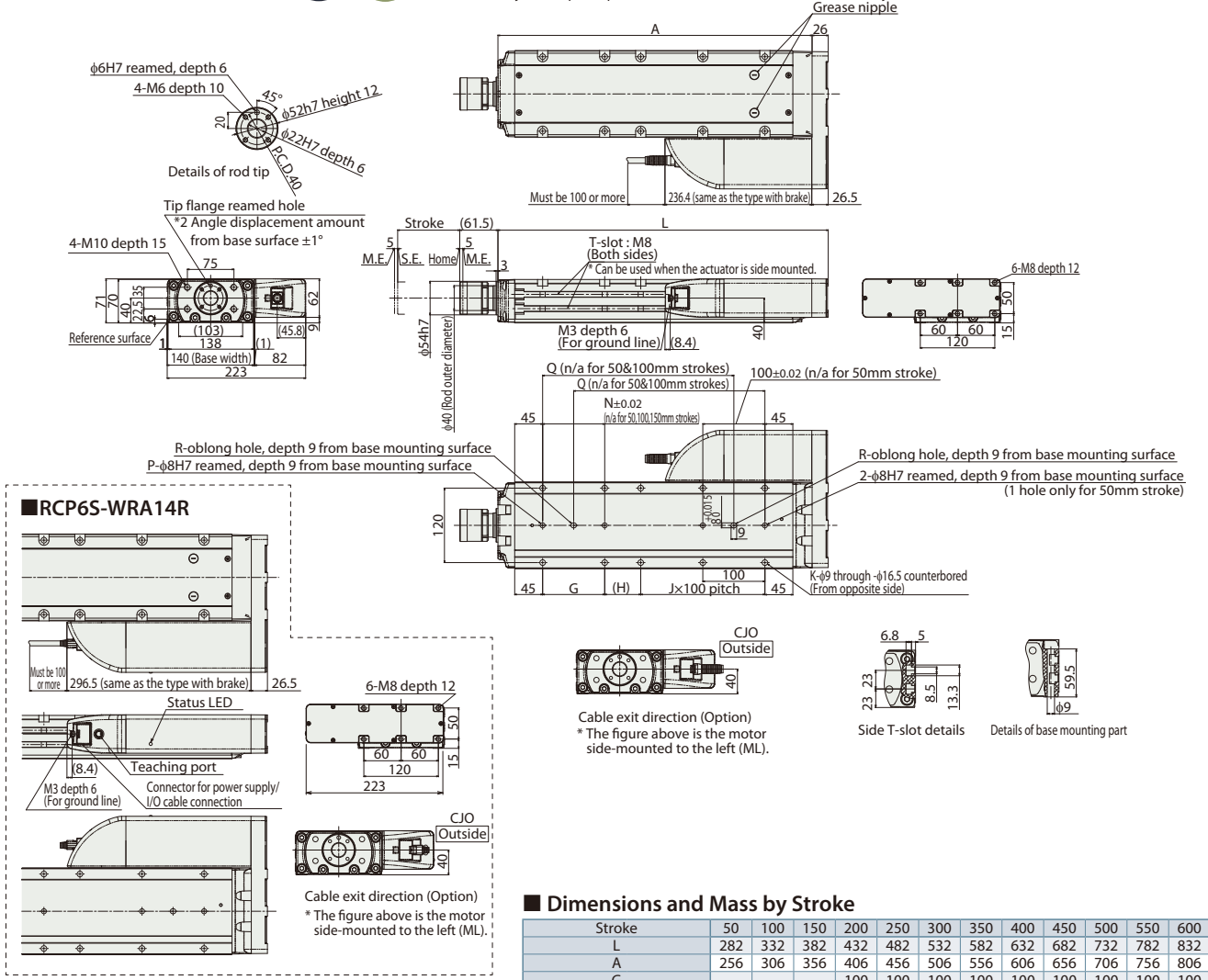

■ Rod Deflection of RCP6(S)-WRA14R (Reference Values)

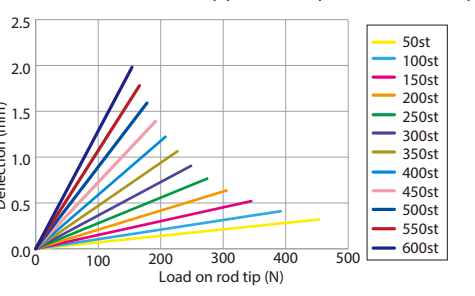

■ Dimensions and Mass by Stroke

Stroke	50	100	150	200	250	300	350	400	450	500	550	600	
L	282	332	382	432	482	532	582	632	682	732	782	832	
A	256	306	356	406	456	506	556	606	656	706	756	806	
G	-	-	-	100	100	100	100	100	100	100	100	100	
H	108	58	108	58	108	58	108	58	108	58	108	58	
J	0	1	1	1	1	2	2	3	3	4	4	5	
K	4	6	6	8	8	10	10	12	12	14	14	16	
N	-	-	-	100	100	100	100	100	100	100	100	100	
P	1	1	1	2	2	2	2	2	2	2	2	2	
Q	-	-	158	208	258	308	358	408	458	508	558	608	
R	0	0	1	1	1	1	1	1	1	1	1	1	
Allowable static load on rod tip (N)	454	392	345	307	276	251	229	210	193	179	166	154	
Allowable static torque on rod tip (N·m)	30	30	30	30	30	30	30	30	30	30	30	30	
3,000km	Allowable dynamic load on rod tip (N)	199	170	148	131	117	104	94	85	77	70	64	
	Load offset 150mm	100	100	100	100	100	95	87	79	72	66	60	
	Allowable dynamic torque on rod tip (N·m)	15.0	15.0	15.0	15.0	15.0	14.3	13.0	11.8	10.8	9.9	9.0	
	Load offset 0mm	167	143	124	109	97	87	78	70	63	57	51	
5,000km	Allowable dynamic load on rod tip (N)	100	100	100	96	87	79	71	65	59	53	48	
	Load offset 150mm	100	100	100	96	87	79	71	65	59	53	48	
	Allowable dynamic torque on rod tip (N·m)	15.0	15.0	15.0	14.4	13.0	11.8	10.7	9.7	8.8	8.0	7.3	
Mass (kg)	RCP6	w/o brake	8.7	9.6	10.5	11.4	12.2	13.1	14.0	14.9	15.7	16.6	17.5
	w/ brake	8.9	9.7	10.6	11.5	12.4	13.2	14.1	15.0	15.9	16.7	17.6	
	RCP6S	w/o brake	8.9	9.8	10.7	11.5	12.4	13.3	14.2	15.0	15.9	16.8	17.7
	w/ brake	9.0	9.9	10.8	11.6	12.5	13.4	14.3	15.2	16.0	16.9	17.8	

② Applicable Controllers

The RCP6 series actuators can be operated by the controllers indicated below. Please select the type depending on your intended use. * Please refer to P.271 for more information about the built-in controller of RCP6S series.

Name	External view	Max. number of controlled axes	Input power	Control method				Maximum number of positioning points	Reference page
				Positioner	Pulse train	Program	Network * Option		
PCON-CYB/PLB/POB		1	DC24V	●	●	-	Network cannot be selected	64	Please contact IAI for more information.
PCON-CB/CGB		1		* Option	* Option	-	DeviceNet MECHATROLINK CC-Link EtherCAT EtherNet/IP CANopen CompoNet	512 (768 for network spec.)	Please see P.255
MCON-C/CG		8		This model is network-compatible only.				256	Please contact IAI for more information.
MCON-LC/LCG		6		-	-	●	Note: The type of compatible networks will vary depending on the controller. Please refer to reference page for more information.	256	Please contact IAI for more information.
MSEL-PC/PG		4	Single-phase 100 ~ 230 VAC	-	-	●		30,000	Please contact IAI for more information.
RCM-P6PC		1	Usable within the RCP6S Gateway system.				768	Please see P.279	

* For the MCON controller, high-output enabled operation is only available if "high-output setting" is selected as an option. The maximum connectable axes with high-output enabled are C: 4 and LC: 3.

Foreword
 Slider Type
 Wide Slider Type
 Rod Type
 Radial Cylinder
 Wide Radial Cylinder
 Table Type
 Cleanroom Slider
 Cleanroom Wide Slider
 Dust/Splash-Proof Rod
 Dust/Splash-Proof Radial Cylinder
 Dust/Splash-Proof Wide Radial Cylinder
 Options
 Reference Data
 Controller

RCP6(S)-WRA16R

Battery-less Absolute

Motor Unit Type

Side-mounted Motor

Body Width 160mm

24v Stepper Motor

Model Specification Items

Series — Type — Encoder Type — Motor Type — Lead — Stroke — Applicable Controller/I/O Type — Cable Length — Options

RCP6: Separate Controller
RCP6S: Built-in Controller

WA: Battery-less Absolute

60P: Stepper Motor
60□ Size

20: 20mm
10: 10mm
5: 5mm

50: 50mm
800: 800mm (50mm increments)

[RCP6]
P4: PCON-CFB/CGFB
[RCP6S]
SE: SIO Type

N: None
P: 1m
S: 3m
M: 5m

Please refer to the options table below.
*Please make sure to specify either ML or MR when ordering the side-mounted motor type.

* RCP6 does not include a controller. RCP6S includes a built-in controller.
* Please refer to P.17 for more information about the model specification items.

* Body width does not include the width of the side-mounted motor.

Radial Load OK



*Some limitations may apply to horizontal/side/ceiling mountings depending on the model. See page 204. Please contact IAI for more information.

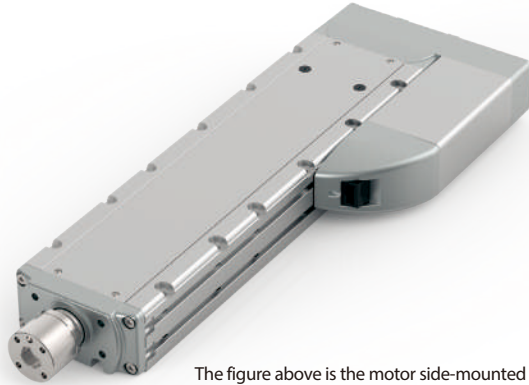

The figure above is the motor side-mounted to the left (ML).

POINT
Selection Notes

- (1) The maximum acceleration/deceleration is 0.1G for lead 5 and 0.2G for lead 10/20.
- (2) The actuator specification displays the payload's maximum value, but it will vary depending on the acceleration and speed. Please refer to the "Selection Guidelines" (Tables of Payload by Speed/Acceleration) on P.221 for more details.
- (3) The radial cylinder is equipped with a built-in guide. Please refer to the graphs shown in P.246 and after for the allowable load mass.
- (4) Please refer to P205 for performing push-motion operation.
- (5) For RCP6S (built-in controller type), please limit the duty cycle to 70% or less.
- (6) The service life of an actuator with lead 5 varies depending on the payload when using vertically. Please refer to P. 206 for more information.

Correlation Diagrams of Speed and Payload

PCON connected.

RCP6(S)-WRA16R Horizontal mount

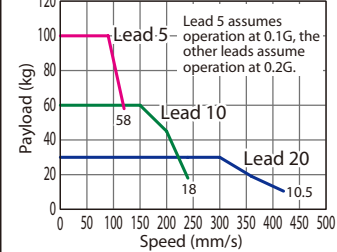

RCP6(S)-WRA16R Vertical mount

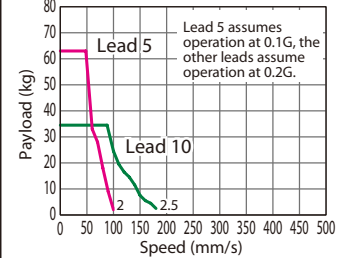

Actuator Specifications

Lead and Payload

* Horizontal external guide rail required for horizontal payload.
** Push force only available during push mode w / limited speed.

Model Number	Lead (mm)	Max. Payload		Max. Push Force (N)**	Stroke (mm)
		Horizontal (kg)*	Vertical (kg)		
RCP6(S)-WRA16R-WA-60P-20-①-②-③-④	20	30	-	500	50~800 (The increment of stroke is 50mm)
RCP6(S)-WRA16R-WA-60P-10-①-②-③-④	10	60	34.5	1,000	
RCP6(S)-WRA16R-WA-60P-5-①-②-③-④	5	100	63	2,000	

Legend: ① Stroke ② Applicable controller/I/O type ③ Cable length ④ Options

Stroke and Max. Speed

(Unit: mm/s)

Lead (mm)	50 (mm)	100 (mm)	150~400 (mm)	450 (mm)	500 (mm)	550 (mm)	600 (mm)	650 (mm)	700 (mm)	750 (mm)	800 (mm)
20	280	405	420	400	340	295	260	225	200	180	
10		240 <180>	230 <180>	195	165	145	125	110	100	90	
5		120 <100>	115 <100>	95	80	70	60	55	50	45	

Values in brackets < > are for vertical use.

① Stroke

Stroke (mm)	RCP6	RCP6S	Stroke (mm)	RCP6	RCP6S
50	○	○	450	○	○
100	○	○	500	○	○
150	○	○	550	○	○
200	○	○	600	○	○
250	○	○	650	○	○
300	○	○	700	○	○
350	○	○	750	○	○
400	○	○	800	○	○

④ Options

Name	Option Code	Reference Page
Brake	B	See P.189
Cable exit direction (Outside)	CJO	See P.189
Flange	FL	See P.190
Motor side-mounted to the left	ML	See P.193
Motor side-mounted to the right	MR	See P.193
Non-motor end specification	NM	See P.194
T-slot nut bar (Left)	NTBL	See P.194
T-slot nut bar (Right)	NTBR	See P.194

* Be sure to confirm with the "Selection Notes (P.196)" when selecting options.
When selecting multiple options, please list them in alphabetical order. (e.g. B-CJB-NM)

③ Cable Length

Cable Type	Cable Code	RCP6	RCP6S
Standard	P (1m)	○	○
	S (3m)	○	○
	M (5m)	○	○
Specified Length	X06 (6m) ~X10 (10m)	○	○
	X11 (11m) ~X15 (15m)	○	○
	X16 (16m) ~X20 (20m)	○	○
	R01 (1m) ~R03 (3m)	○	○
Robot Cable	R04 (4m) ~R05 (5m)	○	○
	R06 (6m) ~R10 (10m)	○	○
	R11 (11m) ~R15 (15m)	○	○
	R16 (16m) ~R20 (20m)	○	○

* Please refer to P.267 and 283 for more information regarding the maintenance cables.

Actuator Specifications

Item	Description
Drive system	Ball screw φ16mm, rolled C10
Positioning repeatability	±0.01mm
Lost motion	0.1mm or less
Rod	φ45mm Stainless steel
Rod non-rotation precision	0 deg.
Allowable load and torque on rod tip	See P. 246
Rod tip overhang distance	150mm or less
Ambient operating temp. & humidity	0~40°C, 85% RH or less (Non-condensing)

CAD drawings can be downloaded from our website.
www.intelligentactuator.com



*1 When the rod is returning to its home position, please be careful of interference from surrounding objects, as it will travel until it reaches the M.E.
M.E: Mechanical end S.E: Stroke end
*2 If the object attached to the rod has a long overhanging length, or precise angular adjustment of the object is required, please do not use the reamed hole when the object is attached to the rod.

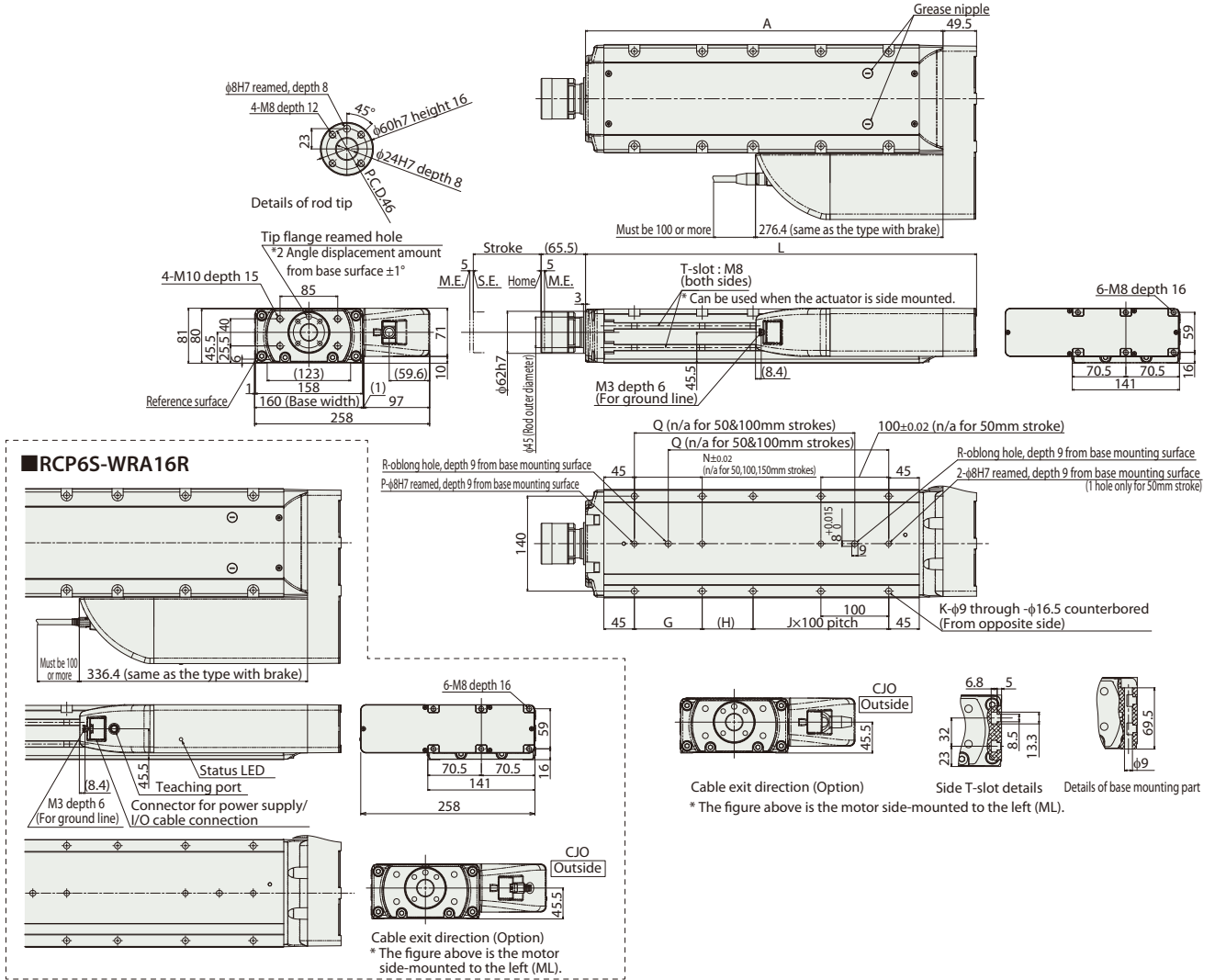

■ Rod Deflection of RCP6(S)-WRA16R (Reference Values)

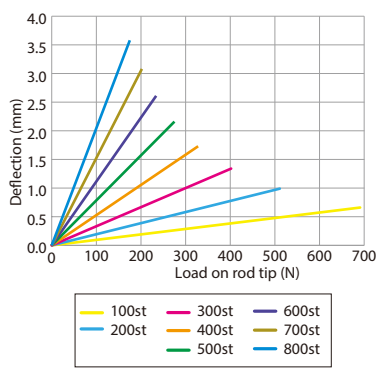

■ Dimensions and Mass by Stroke

Stroke	50	100	150	200	250	300	350	400	450	500	550	600	650	700	750	800	
L	326.5	376.5	426.5	476.5	526.5	576.5	626.5	676.5	726.5	776.5	826.5	876.5	926.5	976.5	1,026.5	1,076.5	
A	277	327	377	427	477	527	577	627	677	727	777	827	877	927	977	1,027	
G	-	-	-	100	100	100	100	100	100	100	100	100	100	100	100	100	
H	125	75	125	75	125	75	125	75	125	75	125	75	125	75	125	75	
J	0	1	1	1	1	2	2	3	3	4	4	5	5	6	6	7	
K	4	6	6	8	8	10	10	12	12	14	14	16	16	18	18	20	
N	-	-	-	100	100	100	100	100	100	100	100	100	100	100	100	100	
P	1	1	1	2	2	2	2	2	2	2	2	2	2	2	2	2	
Q	-	-	175	225	275	325	375	425	475	525	575	625	675	725	775	825	
R	0	0	1	1	1	1	1	1	1	1	1	1	1	1	1	1	
Allowable static load on rod tip (N)	588	588	588	511	451	402	362	329	300	275	254	235	217	202	188	176	
Allowable static torque on rod tip (N·m)	40	40	40	40	40	40	40	40	40	40	40	40	40	40	40	40	
Allowable dynamic Load offset 0mm	255	220	191	168	149	134	120	109	99	90	81	74	67	61	55	50	
3,000km load on rod tip (N) Load offset 150mm	133	133	133	133	133	122	111	101	92	84	77	70	64	58	53	48	
Allowable dynamic torque on rod tip (N·m)	20.0	20.0	20.0	20.0	20.0	18.3	16.7	15.2	13.8	12.6	11.5	10.5	9.6	8.7	7.9	7.1	
5,000km Allowable dynamic Load offset 0mm	214	184	160	140	124	111	99	89	80	72	65	59	53	47	42	37	
load on rod tip (N) Load offset 150mm	133	133	133	124	112	101	91	83	75	68	62	56	50	45	40	36	
Allowable dynamic torque on rod tip (N·m)	20.0	20.0	20.0	18.6	16.8	15.2	13.7	12.4	11.3	10.2	9.2	8.4	7.5	6.8	6.0	5.3	
Mass (kg)	RCP6	w/o brake	13.1	14.2	15.3	16.5	17.6	18.7	19.9	21.0	22.2	23.3	24.5	25.6	26.7	27.9	29.0
	w/ brake	13.3	14.4	15.6	16.7	17.9	19.0	20.1	21.3	22.4	23.5	24.7	25.8	27.0	28.1	29.3	30.4
RCP6S	w/o brake	13.3	14.4	15.6	16.7	17.9	19.0	20.1	21.3	22.4	23.5	24.7	25.8	27.0	28.1	29.2	30.4
w/ brake	13.6	14.7	15.8	16.9	18.1	19.2	20.4	21.5	22.7	23.8	24.9	26.1	27.2	28.3	29.5	30.6	

② Applicable Controllers

The RCP6 series actuators can be operated by the controllers indicated below. Please select the type depending on your intended use. * Please refer to P.271 for more information about the built-in controller of RCP6S series.

Name	External view	Max. number of controlled axes	Input power	Control method			Maximum number of positioning points	Reference page
				Positioner	Pulse train	Program		
PCON-CFB/CGFB		1	DC24V	●	●	-	512 (768 for network spec.)	Please see P.255
				* Option	* Option			
Control method Network * Option DeviceNet CompoNet EtherNet/IP CC-Link MECHATROLINK EtherCAT 								

Foreword
 Slider Type
 Wide Slider Type
 Rod Type
 Radial Cylinder
 Wide Radial Cylinder
 Table Type
 Cleanroom Slider
 Cleanroom Wide Slider
 Dust/Splash-Proof Rod
 Dust/Splash-Proof Radial Cylinder
 Dust/Splash-Proof Wide Radial Cylinder
 Options
 Reference Data
 Controller

RCP6(S)-TA4C <Single Block Specifications>

Battery-less Absolute

Motor Unit Type

Coupled Motor

Body Width 40 mm

24v Stepper Motor

Model Specification Items

Series	Type	Encoder Type	Motor Type	Lead	Stroke	Applicable Controller/I/O Type	Cable Length	Options
RCP6: Separate Controller RCP6S: Built-in Controller	TA4C	WA: Battery-less Absolute	35P: Stepper Motor 35□ Size	16: 16mm 10: 10mm 5: 5mm 2.5: 2.5mm	25: 25mm 150: 150mm (25mm increments)	[RCP6] P3: PCON MCON MSEL P5: RCM-P6PC [RCP6S] SE: SIO Type	N: None P: 1m S: 3m M: 5m X□□: Specified Length R□□: Robot Cable	Please refer to the options table below.

* RCP6 does not include a controller. RCP6S includes a built-in controller.
* Please refer to P.17 for more information about the model specification items.

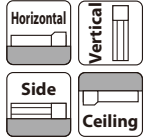

*Some limitations may apply to horizontal/side/ceiling mountings depending on the model. See page 204. Please contact IAI for more information.



Correlation Diagrams of Speed and Payload

(1) High-output enabled with PCON/MCON/MSEL connected.

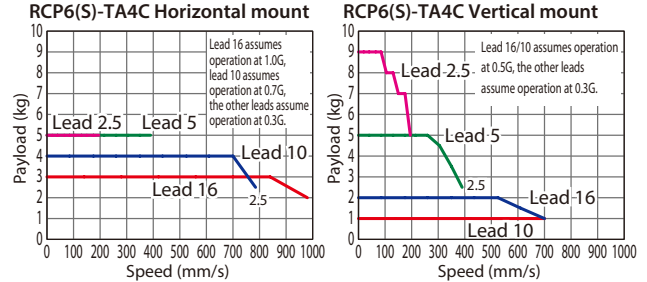

(2) High-output disabled with PCON/MCON connected.

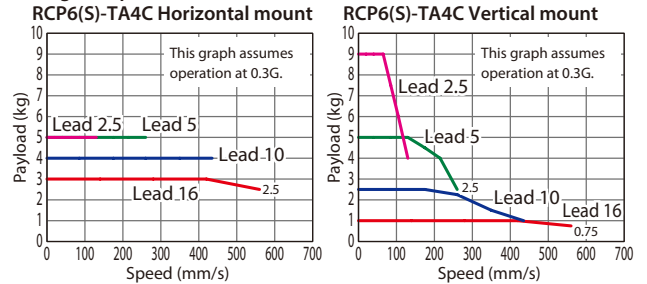

- The maximum acceleration/deceleration is 1G for horizontal, and 0.5G for vertical use.
- The actuator specification displays the payload's maximum value, but it will vary depending on the acceleration and speed. Please refer to the "Selection Guidelines" (Tables of Payload by Speed/Acceleration) on P.227 for more details.
- Please refer to P205 for performing push-motion operation.

Actuator Specifications

Lead and Payload

* Push force only available during push mode w / limited speed.

Model Number	Lead (mm)	Connected Controller	Max. Payload		Max. Push Force (N)*	Stroke (mm)
			Horizontal (kg)	Vertical (kg)		
RCP6(S)-TA4C-WA-35P-16-①-②-③-④	16	High-output Enabled	3	1	48	25~150 (The increment of stroke is 25mm)
		High-output Disabled	3	1		
RCP6(S)-TA4C-WA-35P-10-①-②-③-④	10	High-output Enabled	4	2.5	77	
		High-output Disabled	4	2.5		
RCP6(S)-TA4C-WA-35P-5-①-②-③-④	5	High-output Enabled	5	5	155	
		High-output Disabled	5	5		
RCP6(S)-TA4C-WA-35P-2.5-①-②-③-④	2.5	High-output Enabled	5	10	310	
		High-output Disabled	5	10		
		High-output Disabled	9	9		

Legend: ① Stroke ② Applicable controller/I/O type ③ Cable length ④ Options

Stroke and Max. Speed

(Unit: mm/s)

Lead (mm)	Connected Controller	25~150 (mm)
16	High-output Enabled	980 <700>
	High-output Disabled	840 <560>
10	High-output Enabled	785 <700>
	High-output Disabled	525 <435>
5	High-output Enabled	390
	High-output Disabled	260
2.5	High-output Enabled	195
	High-output Disabled	130

Values in brackets < > are for vertical use.

① Stroke

Stroke (mm)	RCP6	RCP6S
25	○	○
50	○	○
75	○	○
100	○	○
125	○	○
150	○	○

③ Cable Length

Cable Type	Cable Code	RCP6			RCP6S
		P3	P5	SE	
Standard	P (1m)	○	○	○	○
	S (3m)	○	○	○	○
	M (5m)	○	○	○	○
	X06 (6m) ~X10 (10m)	○	○	○	○
Specified Length	X11 (11m) ~X15 (15m)	○	○	○	○
	X16 (16m) ~X20 (20m)	○	○	○	○
	R01 (1m) ~R03 (3m)	○	○	○	○
	R04 (4m) ~R05 (5m)	○	○	○	○
	R06 (6m) ~R10 (10m)	○	○	○	○
	R11 (11m) ~R15 (15m)	○	○	○	○
Robot Cable	R16 (16m) ~R20 (20m)	○	○	○	○

* Please refer to P.267 and 283 for more information regarding the maintenance cables.

④ Options

Name	Option Code	Reference Page
Brake	B	See P.189
Cable exit direction (Top)	CJT	See P.189
Cable exit direction (Right)	CJR	See P.189
Cable exit direction (Left)	CJL	See P.189
Cable exit direction (Bottom)	CJB	See P.189
Non-motor end specification	NM	See P.194

When selecting multiple options, please list them in alphabetical order. (e.g. B-CJB-NM)

Actuator Specifications

Item	Description
Drive system	Ball screw φ8mm, rolled C10
Positioning repeatability	±0.01mm
Lost motion	0.1mm or less
Base	Material: Aluminum with white alumite treatment
Static allowable moment	Ma: 13N·m, Mb: 18.6N·m, Mc: 25.3N·m
Dynamic allowable moment (*)	Ma: 4.98N·m, Mb: 7.11N·m, Mc: 9.68N·m
Ambient operating temp. & humidity	0~40°C, 85% RH or less (Non-condensing)

(*) Assumes a standard rated life of 5,000km. The service life will vary depending on operation and installation conditions.

Please refer to our website for more information regarding the directions of the allowable moment and overhang load length.

Please refer to RCP6 instruction manual regarding the displacement of the table.

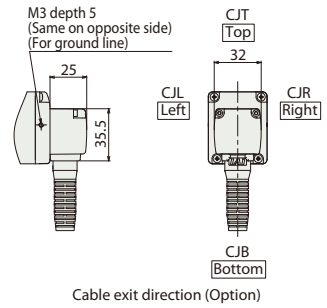
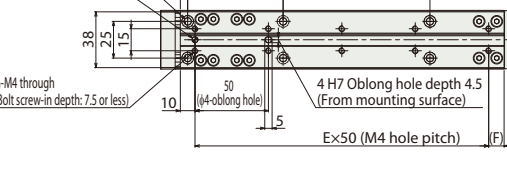
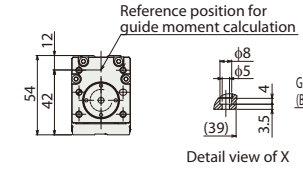
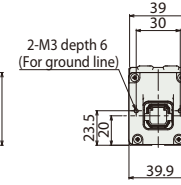
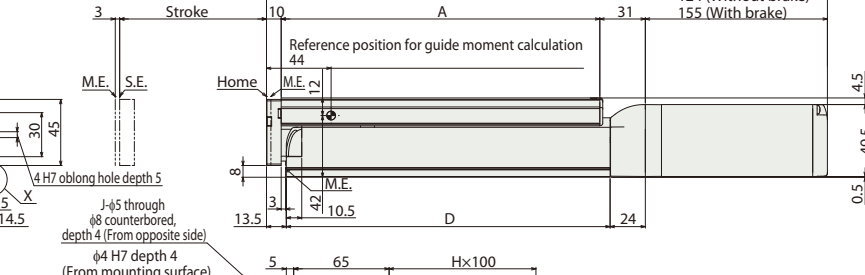
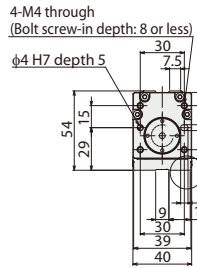
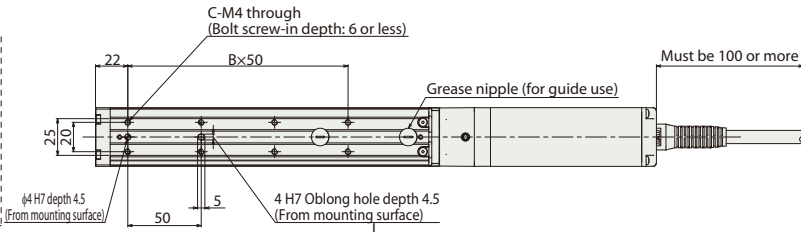
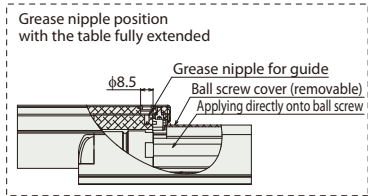

■ RCP6S-TA4C

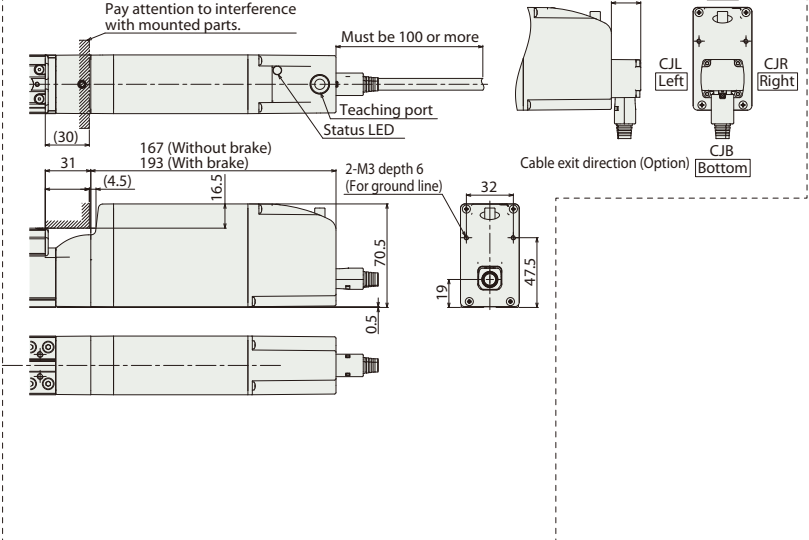

■ Dimensions and Mass by Stroke

		Stroke	25	50	75	100	125	150
L	RCP6	w/o brake	257	282	307	332	357	382
		w/ brake	288	313	338	363	388	413
	RCP6S	w/o brake	300	325	350	375	400	425
		w/ brake	326	351	376	401	426	451
	A		92	117	142	167	192	217
	B		1	1	2	2	3	3
C		4	4	6	6	8	8	
D		95.5	120.5	145.5	170.5	195.5	220.5	
E		1	2	2	3	3	4	
F		35.5	10.5	35.5	10.5	35.5	10.5	
G		4	6	6	8	8	10	
H		0	0	0	0	1	1	
J		4	4	4	4	6	6	
Mass (kg)	RCP6	w/o brake	1.2	1.3	1.4	1.5	1.6	1.6
		w/ brake	1.4	1.4	1.5	1.6	1.7	1.8
	RCP6S	w/o brake	1.4	1.5	1.6	1.7	1.7	1.8
		w/ brake	1.5	1.6	1.7	1.8	1.9	2.0

② Applicable Controllers

The RCP6 series actuators can be operated by the controllers indicated below. Please select the type depending on your intended use. * Please refer to P.271 for more information about the built-in controller of RCP6S series.

Name	External view	Max. number of controlled axes	Input power	Control method				Maximum number of positioning points	Reference page
				Positioner	Pulse train	Program	Network * Option		
PCON-CYB/PLB/POB		1	DC24V	●	●	-	Network cannot be selected	64	Please contact IAI for more information.
PCON-CB/CGB		1		* Option	* Option	-	MECHATROLINK EtherCAT 	512	Please see P.255 (768 for network spec.)
MCON-C/CG		8		This model is network-compatible only.					
MCON-LC/LCG		6		-	-	●		256	Please contact IAI for more information.
MSEL-PC/PG		4	Single-phase 100 ~ 230 VAC	-	-	●	Note: The type of compatible networks will vary depending on the controller. Please refer to reference page for more information.	30,000	Please contact IAI for more information.
RCM-P6PC		1		Usable within the RCP6S Gateway system.				768	Please see P.279

* For the MCON controller, high-output enabled operation is only available if "high-output setting" is selected as an option. The maximum connectable axes with high-output enabled are C: 4 and LC: 3.

Foreword
Slider Type
Wide Slider Type
Rod Type
Radial Cylinder
Wide Radial Cylinder
Table Type
Cleanroom Slider
Cleanroom Wide Slider
Dust/Splash-Proof Rod
Dust/Splash-Proof Radial Cylinder *
Dust/Splash-Proof Wide Radial Cylinder
Options
Reference Data
Controller

RCP6(S)-TA4C <Double Block Specification>

Battery-less Absolute

Motor Unit Type

Coupled Motor

Body Width 40 mm

24v Stepper Motor

Model Specification Items

Series	TA4C	Encoder Type	WA	Motor Type	35P	Lead	Stroke	Applicable Controller/I/O Type	Cable Length	Options
RCP6: Separate Controller RCP6S: Built-in Controller		WA: Battery-less Absolute		35P: Stepper Motor 35□ Size		10 : 10mm 5 : 5mm 2.5 : 2.5mm	40:40mm 240:240mm	[RCP6] P3 : PCON MCON MSEL P5 : RCM-P6PC [RCP6S] SE: SIO Type	N : None P : 1m S : 3m M : 5m XC□ : Specified Length R□□ : Robot Cable	Please refer to the options table below. *Model number symbols should be written in alphabetical order, including "DB".

* RCP6 does not include a controller. RCP6S includes a built-in controller.
* Please refer to P.17 for more information about the model specification items.

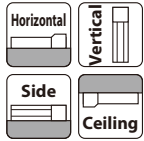

*Some limitations may apply to horizontal/side/ceiling mountings depending on the model. See page 204. Please contact IAI for more information.



Correlation Diagrams of Speed and Payload

(1) High-output enabled with PCON/MCON/MSEL connected.

RCP6(S)-TA4C Horizontal mount

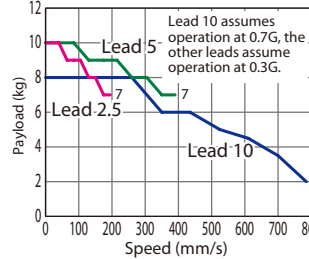

RCP6(S)-TA4C Vertical mount

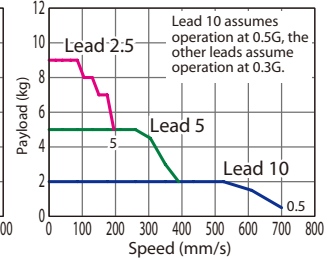

(2) High-output disabled with PCON/MCON connected

RCP6(S)-TA4C Horizontal mount

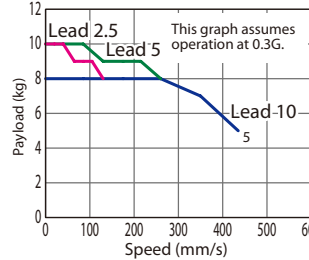

RCP6(S)-TA4C Vertical mount

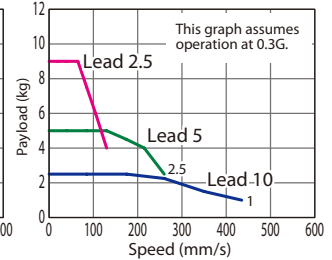

POINT Selection Notes

- The maximum acceleration/deceleration is 1G for horizontal, and 0.5G for vertical use.
- The actuator specifications displays the payload's maximum value, but it will vary depending on the acceleration and speed. Please refer to the "Selection Guidelines" (Tables of Payload by Speed/Acceleration) on P.228 for more details.
- Please refer to P205 for performing push-motion operation.

Actuator Specifications

Lead and Payload

* Push force only available during push mode w / limited speed.

Model Number	Lead (mm)	Connected Controller	Max. Payload		Max. Push Force (N)*	Stroke (mm)
			Horizontal (kg)	Vertical (kg)		
RCP6(S)-TA4C-WA-35P-10-①-②-③-DB-④	10	High-output Enabled	8	2.5	77	40~240
		High-output Disabled				
RCP6(S)-TA4C-WA-35P-5-①-②-③-DB-④	5	High-output Enabled	10	5	155	40~240
		High-output Disabled				
RCP6(S)-TA4C-WA-35P-2.5-①-②-③-DB-④	2.5	High-output Enabled	10	10	310	
		High-output Disabled		9		

Legend: ① Stroke ② Applicable controllers/I/O type ③ Cable length ④ Options

Stroke and Max Speed

(Unit: mm/s)

Lead (mm)	Connected Controller	40~190 (mm)	240 (mm)
10	High-output Enabled	785<700>	680
	High-output Disabled	525<435>	
5	High-output Enabled	390	340
	High-output Disabled	260	
2.5	High-output Enabled	195	170
	High-output Disabled	130	

Values in brackets < > are for vertical use.

① Stroke

Stroke (mm)	RCP6	RCP6S
40	○	○
65	○	○
90	○	○
140	○	○
190	○	○
240	○	○

③ Cable Length

Cable Type	Cable Code	RCP6			RCP6S
		P3	P5	SE	
Standard	P(1m)	○	○	○	○
	S(3m)	○	○	○	○
	M(5m)	○	○	○	○
	X06 (6m) ~X10 (10m)	○	○	○	○
Specified length	X11 (11m) ~X15 (15m)	○	○	○	○
	X16 (16m) ~X20 (20m)	○	○	○	○
	R01 (1m) ~R03 (3m)	○	○	○	○
Robot cable	R04 (4m) ~R05 (5m)	○	○	○	○
	R06 (6m) ~R10 (10m)	○	○	○	○
	R11 (11m) ~R15 (15m)	○	○	○	○
	R16 (16m) ~R20 (20m)	○	○	○	○
		○	○	○	○
		○	○	○	○

* Please refer to P. 267 and 283 for more information regarding the maintenance cables.

④ Options

Name	Option Code	Reference Page
Brake	B	See P.189
Cable exit direction (Top)	CJT	See P.189
Cable exit direction (Right)	CJR	See P.189
Cable exit direction (Left)	CJL	See P.189
Cable exit direction (Bottom)	CJB	See P.189
Non-motor end specification	NM	See P.194

Actuator Specifications

Item	Description
Drive system	Ball screw φ8mm, rolled C10
Positioning repeatability	±0.01mm
Lost motion	0.1mm or less
Base	Material: Aluminum with white alumite treatment
Static allowable moment	Ma: 76.8N-m, Mb: 110N-m, Mc: 50.5N-m
Dynamic allowable moment (*)	Ma: 23.9N-m, Mb: 34.1N-m, Mc: 15.7N-m
Ambient operating temp. & humidity	0~40°C, 85% RH or less (Non-condensing)

(*) Assumes a standard rated life of 5,000km. The service life will vary depending on operation and installation conditions.

Please refer to our website for more information regarding the directions of the allowable moment and overhang load length.
Please refer to RCP6 instruction manual regarding the displacement of the table.



*1 When the table is returning to its home position, please be careful of interference from surrounding objects, as it will travel until it reaches the M.E.
M.E: Mechanical end S.E: Stroke end

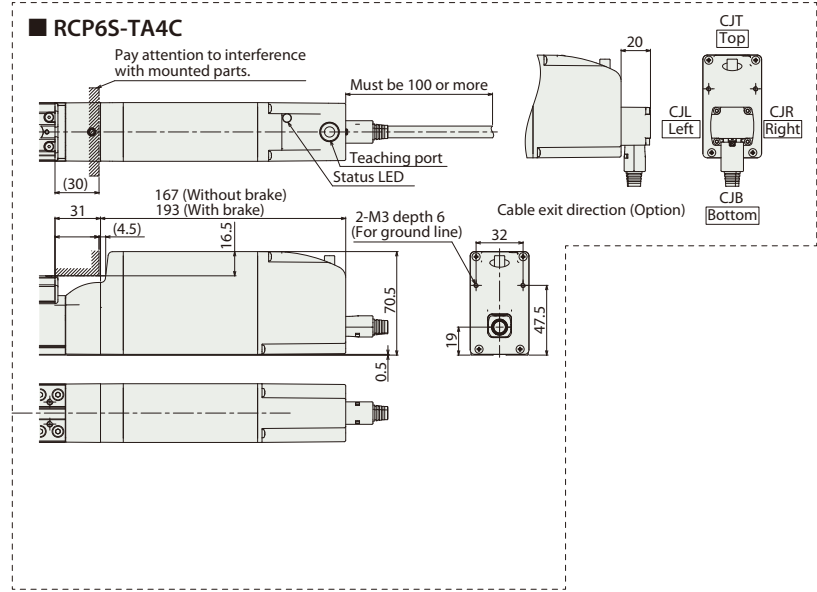
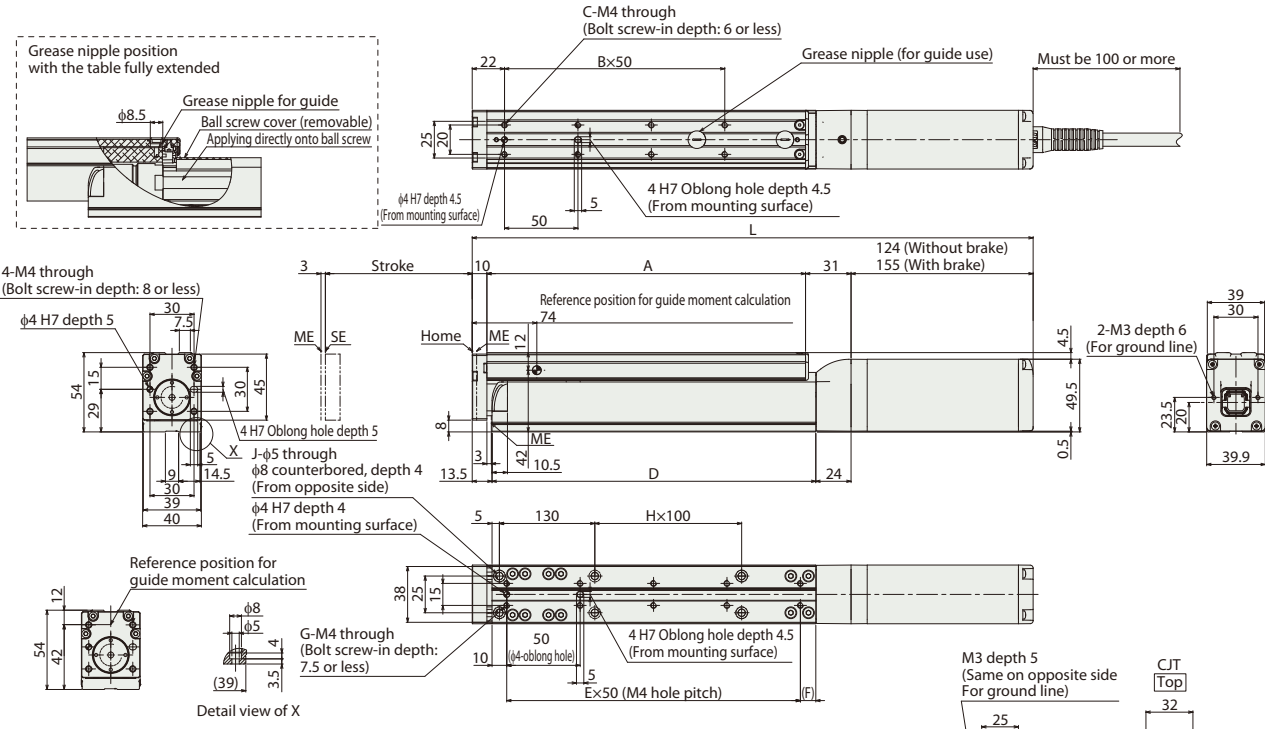

■ Dimensions and Mass by Stroke

L	Stroke	40	65	90	140	190	240
		RCP6	w/o brake 332	w/o brake 357	w/o brake 382	w/o brake 432	w/o brake 482
RCP6S	w/o brake	363	388	413	463	513	563
	w/ brake	375	400	425	475	525	575
A	w/o brake	401	426	451	501	551	601
	w/ brake	167	192	217	267	317	367
B		2	3	3	4	5	6
C		6	8	8	10	12	14
D		170.5	195.5	220.5	270.5	320.5	370.5
E		3	3	4	5	6	7
F		10.5	35.5	10.5	10.5	10.5	10.5
G		8	8	10	12	14	16
H		0	0	0	1	1	2
J		4	4	4	6	6	8
Mass (kg)	RCP6	w/o brake 1.5	w/o brake 1.6	w/o brake 1.7	w/o brake 1.9	w/o brake 2.1	w/o brake 2.2
	w/ brake	1.7	1.8	1.9	2.0	2.2	2.4
RCP6S	w/o brake	1.7	1.8	1.9	2.1	2.3	2.4
	w/ brake	1.9	2.0	2.1	2.2	2.4	2.6

② Applicable Controllers

The RCP6 series actuators can be operated by the controllers indicated below. Please select the type depending on your intended use. * Please refer to P.271 for more information about the built-in controller of RCP6S series.

Name	External view	Max. number of controlled axes	Input power	Control method				Maximum number of positioning points	Reference page
				Positioner	Pulse train	Program	Network * Option		
PCON-CYB/PLB/POB		1	DC24V	●	●	—	Network cannot be selected	64	Please contact IAI for more information.
PCON-CB/CGB		1		* Option	* Option	—	MECHATROLINK EtherCAT 	512	Please see P.255 (768 for network spec.)
MCON-C/CG		8		This model is network-compatible only.					
MCON-LC/LCG		6		—	—	●		256	Please contact IAI for more information.
MSEL-PC/PG		4	Single-phase 100 ~ 230 VAC	—	—	●	Note: The type of compatible networks will vary depending on the controller. Please refer to reference page for more information.	30,000	Please contact IAI for more information.
RCM-P6PC		1		Usable within the RCP6S Gateway system.				768	Please see P.279

* For the MCON controller, high-output enabled operation is only available if "high-output setting" is selected as an option. The maximum connectable axes with high-output enabled are C: 4 and LC: 3.

Foreword
Slider Type
Wide Slider Type
Rod Type
Radial Cylinder
Wide Radial Cylinder
Table Type
Cleanroom Slider
Cleanroom Wide Slider
Dust/Splash-Proof Rod
Dust/Splash-Proof Radial Cylinder *
Dust/Splash-Proof Wide Radial Cylinder
Options
Reference Data
Controller

RCP6(S)-TA6C <Single Block Specifications>

Battery-less Absolute

Motor Unit Type

Coupled Motor

Body Width **58 mm**

24v Stepper Motor

Model Specification Items

Series	Type	Encoder Type	Motor Type	Lead	Stroke	Applicable Controller/I/O Type	Cable Length	Options
RCP6: Separate Controller RCP6S: Built-in Controller	TA6C	WA: Battery-less Absolute	42P: Stepper Motor 42□ Size	20: 20mm 12: 12mm 6: 6mm 3: 3mm	25: 25mm 200: 200mm (25mm increments)	[RCP6] P3: PCON MCON MSEL P5: RCM-P6PC [RCP6S] SE: SIO Type	N: None P: 1m S: 3m M: 5m X□□: Specified Length R□□: Robot Cable	Please refer to the options table below.

* RCP6 does not include a controller. RCP6S includes a built-in controller.
* Please refer to P.17 for more information about the model specification items.

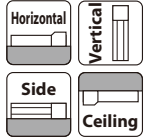

*Some limitations may apply to horizontal/side/ceiling mountings depending on the model. See page 204. Please contact IAI for more information.



Correlation Diagrams of Speed and Payload

(1) High-output enabled with PCON/MCON/MSEL connected.

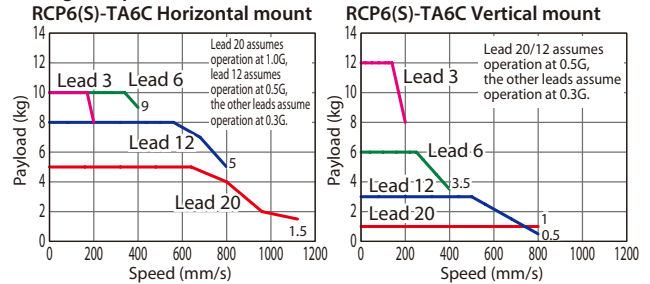

(2) High-output disabled with PCON/MCON connected.

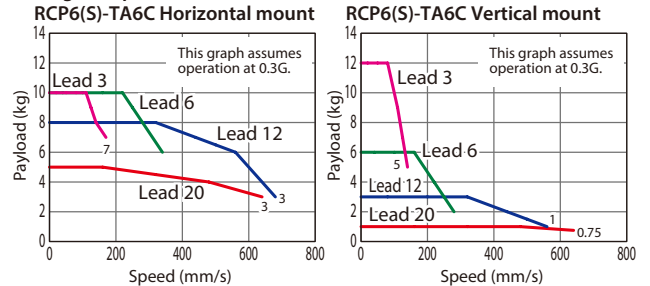

- POINT Selection Notes**
- The maximum acceleration/deceleration is 1G for horizontal, and 0.5G for vertical use.
 - The actuator specification displays the payload's maximum value, but it will vary depending on the acceleration and speed. Please refer to the "Selection Guidelines" (Tables of Payload by Speed/Acceleration) on P.227 for more details.
 - Please refer to P.205 for performing push-motion operation.
 - Depending on the ambient operational temperature, duty control is necessary for the RCP6S (built-in controller type) with lead 3/6. Please refer to P.247 for more information.

Actuator Specifications

Lead and Payload

* Push force only available during push mode w / limited speed.

Model Number	Lead (mm)	Connected Controller	Max. Payload		Max. Push Force (N)*	Stroke (mm)
			Horizontal (kg)	Vertical (kg)		
RCP6(S)-TA6C-WA-42P-20-①②③④	20	High-output Enabled	5	1	56	25~200 (The increment of stroke is 25mm)
		High-output Disabled	5	1		
RCP6(S)-TA6C-WA-42P-12-①②③④	12	High-output Enabled	8	3	93	
		High-output Disabled	8	3		
RCP6(S)-TA6C-WA-42P-6-①②③④	6	High-output Enabled	10	6	185	
		High-output Disabled	10	6		
RCP6(S)-TA6C-WA-42P-3-①②③④	3	High-output Enabled	10	12	370	
		High-output Disabled	10	12		

Legend: ① Stroke ② Applicable controller/I/O type ③ Cable length ④ Options

Stroke and Max. Speed

(Unit: mm/s)

Lead (mm)	Connected Controller	25~200 (mm)
20	High-output Enabled	1,120 <800>
	High-output Disabled	800 <640>
12	High-output Enabled	800
	High-output Disabled	680 <560>
6	High-output Enabled	400
	High-output Disabled	340 <280>
3	High-output Enabled	200
	High-output Disabled	170 <140>

Values in brackets < > are for vertical use.

① Stroke

Stroke (mm)	RCP6	RCP6S
25	○	○
50	○	○
75	○	○
100	○	○
125	○	○
150	○	○
175	○	○
200	○	○

③ Cable Length

Cable Type	Cable Code	RCP6			RCP6S
		P3	P5	SE	
Standard	P (1m)	○	○	○	○
	S (3m)	○	○	○	○
	M (5m)	○	○	○	○
	X06 (6m) ~X10 (10m)	○	○	○	○
Specified Length	X11 (11m) ~X15 (15m)	○	○	○	○
	X16 (16m) ~X20 (20m)	○	○	○	○
	R01 (1m) ~R03 (3m)	○	○	○	○
	R04 (4m) ~R05 (5m)	○	○	○	○
Robot Cable	R06 (6m) ~R10 (10m)	○	○	○	○
	R11 (11m) ~R15 (15m)	○	○	○	○
	R16 (16m) ~R20 (20m)	○	○	○	○

* Please refer to P.267 and 283 for more information regarding the maintenance cables.

④ Options

Name	Option Code	Reference Page
Brake	B	See P.189
Cable exit direction (Top)	CJT	See P.189
Cable exit direction (Right)	CJR	See P.189
Cable exit direction (Left)	CJL	See P.189
Cable exit direction (Bottom)	CJB	See P.189
Non-motor end specification	NM	See P.194

When selecting multiple options, please list them in alphabetical order. (e.g. B-CJB-NM)

Actuator Specifications

Item	Description
Drive system	Ball screw φ10mm, rolled C10
Positioning repeatability	±0.01mm
Lost motion	0.1mm or less
Base	Material: Aluminum with white alumite treatment
Static allowable moment	Ma: 32.3N·m, Mb: 46.2N·m, Mc: 68.3N·m
Dynamic allowable moment (*)	Ma: 11.6N·m, Mb: 16.6N·m, Mc: 24.6N·m
Ambient operating temp. & humidity	0~40°C, 85% RH or less (Non-condensing)

(*) Assumes a standard rated life of 5,000km. The service life will vary depending on operation and installation conditions.

Please refer to our website for more information regarding the directions of the allowable moment and overhang load length.

Please refer to RCP6 instruction manual regarding the displacement of the table.

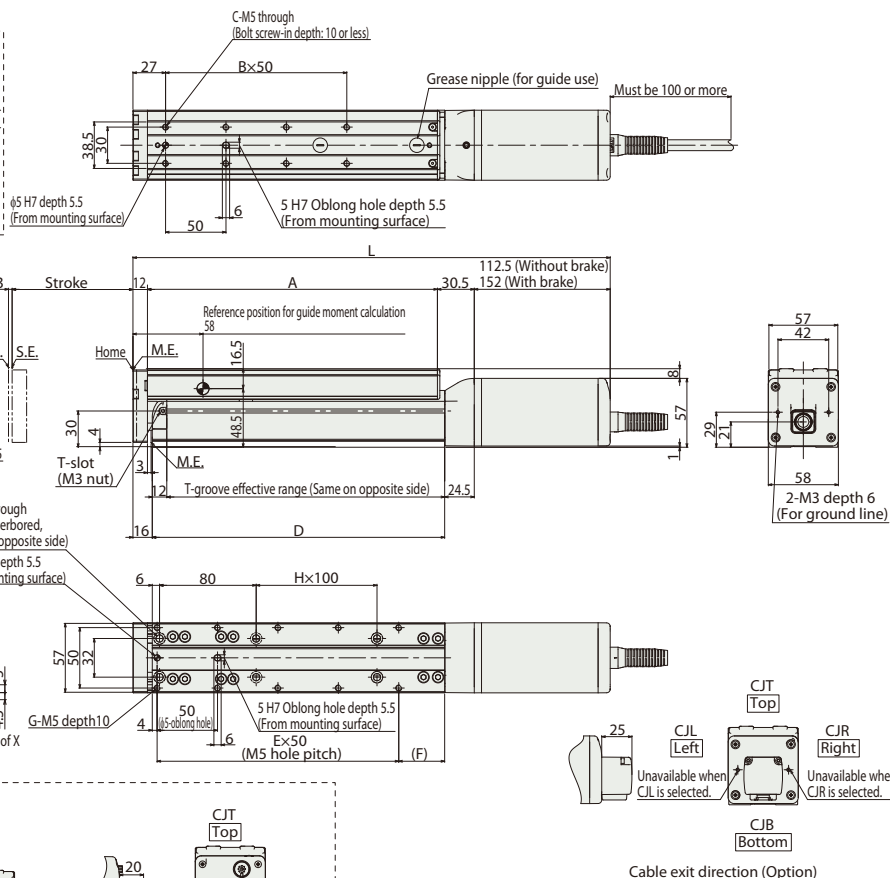
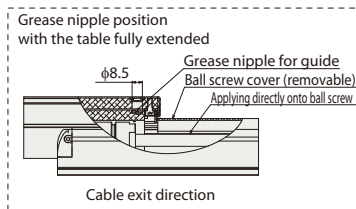

RCP6S-TA6C

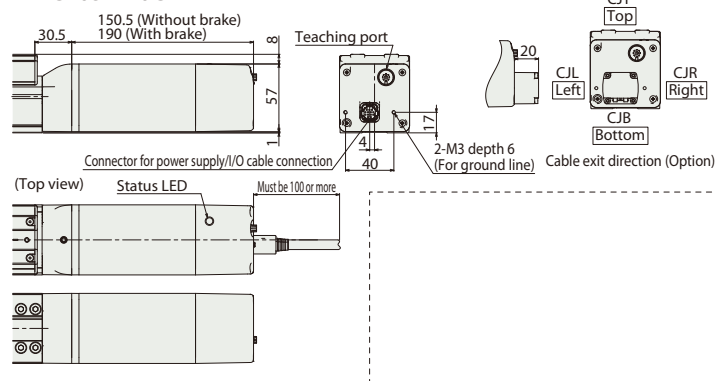

Dimensions and Mass by Stroke

Stroke		25	50	75	100	125	150	175	200	
L	RCP6	w/o brake	270	295	320	345	370	395	420	445
		w/ brake	309.5	334.5	359.5	384.5	409.5	434.5	459.5	484.5
	RCP6S	w/o brake	308	333	358	383	408	433	458	483
		w/ brake	347.5	372.5	397.5	422.5	447.5	472.5	497.5	522.5
A		115	140	165	190	215	240	265	290	
B		1	1	2	2	3	3	4	4	
C		4	4	6	6	8	8	10	10	
D		117	142	167	192	217	242	267	292	
E		2	2	3	3	4	4	5	5	
F		13	38	13	38	13	38	13	38	
G		6	6	8	8	10	10	12	12	
H		0	0	0	0	1	1	1	1	
J		4	4	4	4	6	6	6	6	
Mass (kg)	RCP6	w/o brake	2.1	2.2	2.4	2.5	2.7	2.9	3.0	3.2
		w/ brake	2.3	2.5	2.6	2.8	2.9	3.1	3.3	3.4
	RCP6S	w/o brake	2.2	2.4	2.5	2.7	2.8	3.0	3.2	3.3
		w/ brake	2.4	2.6	2.8	2.9	3.1	3.2	3.4	3.6

② Applicable Controllers

The RCP6 series actuators can be operated by the controllers indicated below. Please select the type depending on your intended use. * Please refer to P.271 for more information about the built-in controller of RCP6S series.

Name	External view	Max. number of controlled axes	Input power	Control method				Maximum number of positioning points	Reference page
				Positioner	Pulse train	Program	Network * Option		
PCON-CYB/PLB/POB		1	DC24V	●	●	—	Network cannot be selected	64	Please contact IAI for more information.
PCON-CB/CGB		1		* Option	●	—	DeviceNet MECHATROLINK EtherCAT EtherNet/IP CC-Link CompoNet	512 (768 for network spec.)	Please see P.255
MCON-C/CG		8		—	●	—		Note: The type of compatible networks will vary depending on the controller. Please refer to reference page for more information.	256
MCON-LC/LCG		6		—	—	●	SSCNET III/H		256
MSEL-PC/PG		4	Single-phase 100 ~ 230 VAC	—	—	●		30,000	Please contact IAI for more information.
RCM-P6PC		1		Usable within the RCP6S Gateway system.				768	Please see P.279

* For the MCON controller, high-output enabled operation is only available if "high-output setting" is selected as an option. The maximum connectable axes with high-output enabled are C: 4 and LC: 3.

Foreword
Slider Type
Wide Slider Type
Rod Type
Radial Cylinder
Wide Radial Cylinder
Table Type
Cleanroom Slider
Cleanroom Wide Slider
Dust/Splash-Proof Rod
Dust/Splash-Proof Radial Cylinder
Dust/Splash-Proof Wide Radial Cylinder
Options
Reference Data
Controller

RCP6(S)-TA6C <Double Block Specification>

Battery-less Absolute Motor Unit Type Coupled Motor Body Width 58 mm 24v Stepper Motor

Model Specification Items

Series	TA6C	Type	WA	Encoder Type	42P	Lead	Stroke	Applicable Controller/I/O Type	Cable Length	Options
RCP6: Separate Controller RCP6S: Built-in Controller		WA: Battery-less Absolute		42P: Stepper Motor 42□ Size	12: 12mm 6: 6mm 3: 3mm	45: 45mm 320: 320mm	[RCP6] P3: PCON MCON MSEL P5: RCM-P6PC [RCP6S] SE: SIO Type	N: None P: 1m S: 3m M: 5m XC□□: Specified Length R□□: Robot Cable	Please refer to the options table below. *Model number symbols should be written in alphabetical order, including "DB".	

* RCP6 does not include a controller. RCP6S includes a built-in controller.
* Please refer to P.17 for more information about the model specification items.

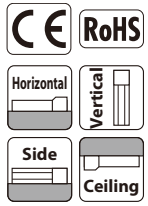

*Some limitations may apply to horizontal/side/ceiling mountings depending on the model. See page 204. Please contact IAI for more information.

POINT Selection Notes

- (1) The maximum acceleration/deceleration is 1G for horizontal, and 0.5G for vertical use.
- (2) The actuator specifications displays the payload's maximum value, but it will vary depending on the acceleration and speed. Please refer to the "Selection Guidelines" (Tables of Payload by Speed/Acceleration) on P.228 for more details.
- (3) Please refer to P205 for performing push-motion operation.
- (4) Depending on the ambient operating temperature, duty control is necessary for the RCP6S (built-in controller type) with lead 3/6. Please refer to P.247 for more information.

Correlation Diagrams of Speed and Payload

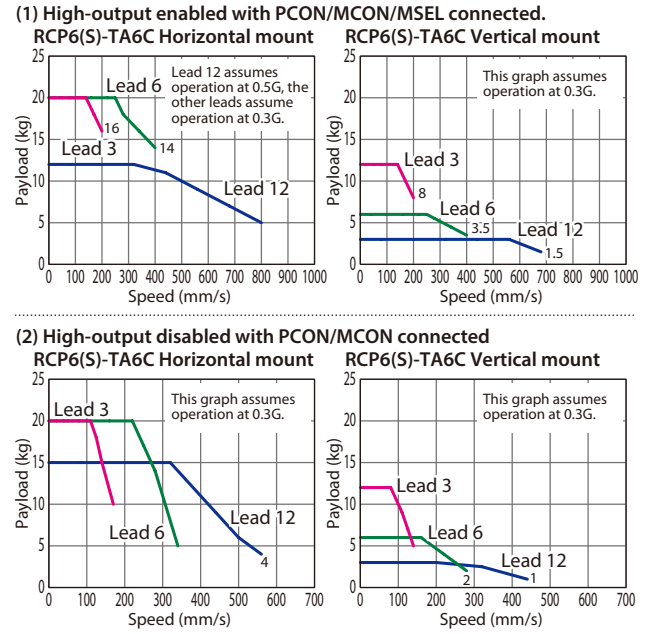

Actuator Specifications

Model Number	Lead (mm)	Connected Controller	Max. Payload		Max. Push Force (N)*	Stroke (mm)	Stroke and Max Speed (Unit: mm/s)				
			Horizontal (kg)	Vertical (kg)			Lead (mm)	Connected Controller	45~220 (mm)	270 (mm)	320 (mm)
RCP6(S)-TA6C-WA-42P-12-①-②-③-DB-④	12	High-output Enabled	15	3	93	45~320	12	High-output Enabled	800<680>	735<680>	575
		High-output Disabled						560<440>			
RCP6(S)-TA6C-WA-42P-6-①-②-③-DB-④	6	High-output Enabled	20	6	185	45~320	6	High-output Enabled	400	365	285
		High-output Disabled						340<280>			
RCP6(S)-TA6C-WA-42P-3-①-②-③-DB-④	3	High-output Enabled	20	12	370	45~320	3	High-output Enabled	200	185	140
		High-output Disabled						170<140>			

Legend: ① Stroke ② Applicable controllers/I/O type ③ Cable length ④ Options

* Push force only available during push mode w / limited speed. Values in brackets <> are for vertical use.

① Stroke

Stroke (mm)	RCP6	RCP6S
45	○	○
70	○	○
95	○	○
120	○	○
170	○	○
220	○	○
270	○	○
320	○	○

③ Cable Length

Cable Type	Cable Code	RCP6			RCP6S
		P3	P5	SE	
Standard	P(1m)	○	○	○	
	S(3m)	○	○	○	
	M(5m)	○	○	○	
Specified length	X06 (6m) ~X10 (10m)	○	○	○	
	X11 (11m) ~X15 (15m)	○	○	○	
	X16 (16m) ~X20 (20m)	○	○	○	
	X21 (21m) ~X25 (25m)	○	○	○	
Robot cable	R01 (1m) ~R03 (3m)	○	○	○	
	R04 (4m) ~R05 (5m)	○	○	○	
	R06 (6m) ~R10 (10m)	○	○	○	
	R11 (11m) ~R15 (15m)	○	○	○	
	R16 (16m) ~R20 (20m)	○	○	○	
	R21 (21m) ~R25 (25m)	○	○	○	

* Please refer to P. 267 and 283 for more information regarding the maintenance cables.

④ Options

Name	Option Code	Reference Page
Brake	B	See P.189
Cable exit direction (Top)	CJT	See P.189
Cable exit direction (Right)	CJR	See P.189
Cable exit direction (Left)	CJL	See P.189
Cable exit direction (Bottom)	CJB	See P.189
Non-motor end specification	NM	See P.194

Actuator Specifications

Item	Description
Drive system	Ball screw φ10mm, rolled C10
Positioning repeatability	±0.01mm
Lost motion	0.1mm or less
Base	Material: Aluminum with white alumite treatment
Static allowable moment	Ma: 169N·m, Mb: 242N·m, Mc: 137N·m
Dynamic allowable moment (*)	Ma: 49.5N·m, Mb: 70.7N·m, Mc: 40N·m
Ambient operating temp. & humidity	0~40°C, 85% RH or less (Non-condensing)

(*) Assumes a standard rated life of 5,000km. The service life will vary depending on operation and installation conditions.

Please refer to our website for more information regarding the directions of the allowable moment and overhang load length. Please refer to RCP6 instruction manual regarding the displacement of the table.

*1 When the table is returning to its home position, please be careful of interference from surrounding objects, as it will travel until it reaches the M.E.
M.E: Mechanical end S.E: Stroke end

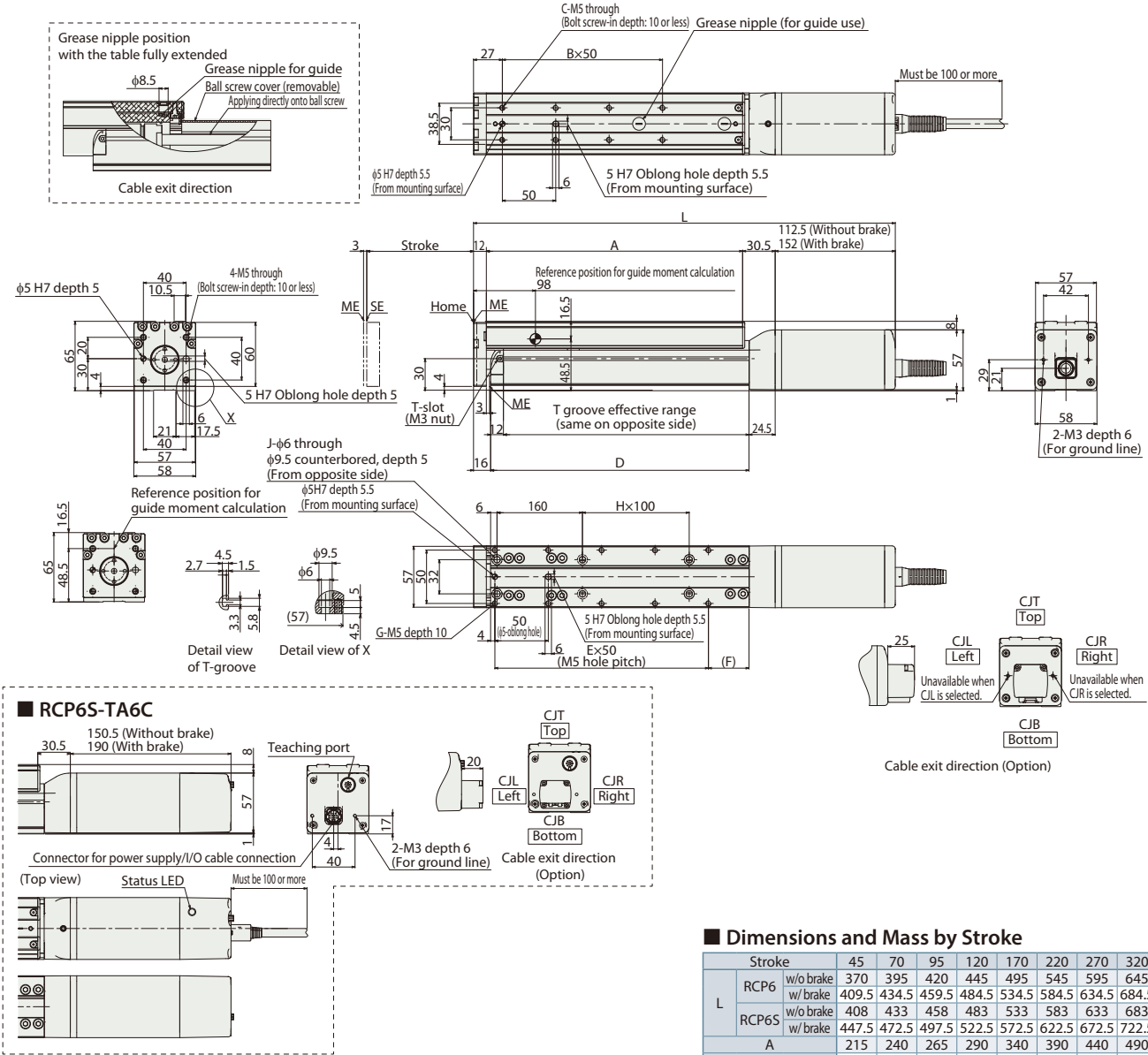

② Applicable Controllers

The RCP6 series actuators can be operated by the controllers indicated below. Please select the type depending on your intended use. * Please refer to P.271 for more information about the built-in controller of RCP6S series.

Name	External view	Max. number of controlled axes	Input power	Control method				Maximum number of positioning points	Reference page
				Positioner	Pulse train	Program	Network * Option		
PCON-CYB/PLB/POB		1	DC24V	●	●	—	Network cannot be selected	64	Please contact IAI for more information.
PCON-CB/CGB		1		* Option	* Option	—	MECHATROLINK EtherCAT 	512 (768 for network spec.)	Please see P.255
MCON-C/CG		8		This model is network-compatible only.				256	Please contact IAI for more information.
MCON-LC/LCG		6		—	—	●		256	Please contact IAI for more information.
MSEL-PC/PG		4	Single-phase 100 ~ 230 VAC	—	—	●	Note: The type of compatible networks will vary depending on the controller. Please refer to reference page for more information.	30,000	Please contact IAI for more information.
RCM-P6PC		1		Usable within the RCP6S Gateway system.				768	Please see P.279

* For the MCON controller, high-output enabled operation is only available if "high-output setting" is selected as an option. The maximum connectable axes with high-output enabled are C: 4 and LC: 3.

Foreword
Slider Type
Wide Slider Type
Rod Type
Radial Cylinder
Wide Radial Cylinder
Table Type
Cleanroom Slider
Cleanroom Wide Slider
Dust/Splash-Proof Rod
Dust/Splash-Proof Radial Cylinder *
Dust/Splash-Proof Wide Radial Cylinder
Options
Reference Data
Controller

RCP6(S)-TA7C <Single Block Specifications>

Battery-less Absolute

Motor Unit Type

Coupled Motor

Body Width 70 mm

24v Stepper Motor

Model Specification Items	Series	Type	Encoder Type	Motor Type	Lead	Stroke	Applicable Controller/I/O Type	Cable Length	Options
	RCP6: Separate Controller RCP6S: Built-in Controller	TA7C	WA	56P	24: 24mm 16: 16mm 8: 8mm 4: 4mm	25: 25mm 300: 300mm	[RCP6] P3: PCON MCON MSEL P5: RCM-P6PC [RCP6S] SE: SIO Type	N: None P: 1m S: 3m M: 5m X□□: Specified Length R□□: Robot Cable	Please refer to the options table below.

* RCP6 does not include a controller. RCP6S includes a built-in controller.
* Please refer to P.17 for more information about the model specification items.

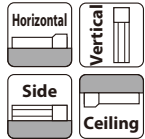

*Some limitations may apply to horizontal/side/ceiling mountings depending on the model. See page 204. Please contact IAI for more information.



POINT Selection Notes

- (1) The maximum acceleration/deceleration is 1G for horizontal, and 0.5G for vertical use.
- (2) The actuator specification displays the payload's maximum value, but it will vary depending on the acceleration and speed. Please refer to the "Selection Guidelines" (Tables of Payload by Speed/Acceleration) on P.227 for more details.
- (3) Please refer to P.205 for performing push-motion operation.
- (4) Depending on the ambient operational temperature, duty control is necessary for the RCP6S (built-in controller type) with lead 4/8/16. Please refer to P.247 for more information.

Correlation Diagrams of Speed and Payload

(1) High-output enabled with PCON/MCON/MSEL connected.

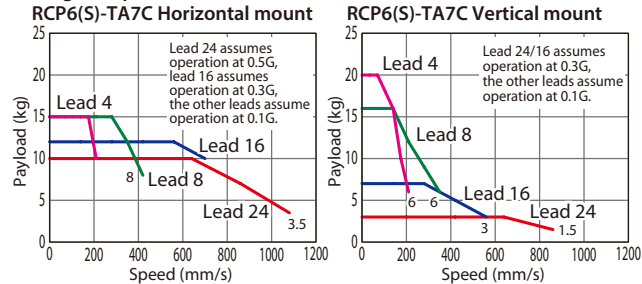

(2) High-output disabled with PCON/MCON connected.

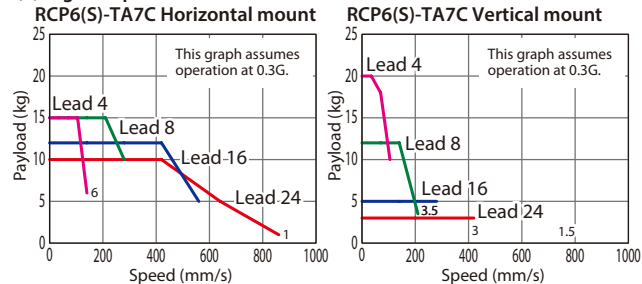

Actuator Specifications

Lead and Payload

* Push force only available during push mode w / limited speed.

Model Number	Lead (mm)	Connected Controller	Max. Payload		Max. Push Force (N)*	Stroke (mm)
			Horizontal (kg)	Vertical (kg)		
RCP6(S)-TA7C-WA-56P-24-①②③④	24	High-output Enabled	10	3	112	25~300
		High-output Disabled	10	3		
RCP6(S)-TA7C-WA-56P-16-①②③④	16	High-output Enabled	12	7	168	
		High-output Disabled	12	5		
RCP6(S)-TA7C-WA-56P-8-①②③④	8	High-output Enabled	15	16	336	
		High-output Disabled	15	12		
RCP6(S)-TA7C-WA-56P-4-①②③④	4	High-output Enabled	15	20	673	
		High-output Disabled	15	20		

Legend: ① Stroke ② Applicable controller/I/O type ③ Cable length ④ Options

Stroke and Max. Speed

(Unit: mm/s)

Lead (mm)	Connected Controller	25~300 (mm)
24	High-output Enabled	1,080 <860>
	High-output Disabled	860 <420>
16	High-output Enabled	700 <560>
	High-output Disabled	560 <280>
8	High-output Enabled	420 <350>
	High-output Disabled	280 <210>
4	High-output Enabled	210
	High-output Disabled	140 <105>

Values in brackets < > are for vertical use.

① Stroke

Stroke (mm)	RCP6	RCP6S
25	○	○
50	○	○
75	○	○
100	○	○
125	○	○
150	○	○
175	○	○
200	○	○
250	○	○
300	○	○

③ Cable Length

Cable Type	Cable Code	RCP6			RCP6S
		P3	P5	SE	
Standard	P (1m)	○	○	○	
	S (3m)	○	○	○	
	M (5m)	○	○	○	
Specified Length	X06 (6m) ~X10 (10m)	○	○	○	
	X11 (11m) ~X15 (15m)	○	○	○	
	X16 (16m) ~X20 (20m)	○	○	○	
	X21 (21m) ~X25 (25m)	○	○	○	
Robot Cable	R01 (1m) ~R03 (3m)	○	○	○	
	R04 (4m) ~R05 (5m)	○	○	○	
	R06 (6m) ~R10 (10m)	○	○	○	
	R11 (11m) ~R15 (15m)	○	○	○	
	R16 (16m) ~R20 (20m)	○	○	○	
	R21 (21m) ~R25 (25m)	○	○	○	

* Please refer to P.267 and 283 for more information regarding the maintenance cables.

④ Options

Name	Option Code	Reference Page
Brake	B	See P.189
Cable exit direction (Top)	CJT	See P.189
Cable exit direction (Right)	CJR	See P.189
Cable exit direction (Left)	CJL	See P.189
Cable exit direction (Bottom)	CJB	See P.189
Non-motor end specification	NM	See P.194

When selecting multiple options, please list them in alphabetical order. (e.g. B-CJB-NM)

Actuator Specifications

Item	Description
Drive system	Ball screw φ12mm, rolled C10
Positioning repeatability	±0.01mm
Lost motion	0.1mm or less
Base	Material: Aluminum with white alumite treatment
Static allowable moment	Ma: 115N·m, Mb: 115N·m, Mc: 229N·m
Dynamic allowable moment (*)	Ma: 44.7N·m, Mb: 44.7N·m, Mc: 89.1N·m
Ambient operating temp. & humidity	0~40°C, 85% RH or less (Non-condensing)

(*) Assumes a standard rated life of 5,000km. The service life will vary depending on operation and installation conditions.

Please refer to our website for more information regarding the directions of the allowable moment and overhang load length.

Please refer to RCP6 instruction manual regarding the displacement of the table.



*1 When the table is returning to its home position, please be careful of interference from surrounding objects, as it will travel until it reaches the M.E.
M.E: Mechanical end S.E: Stroke end

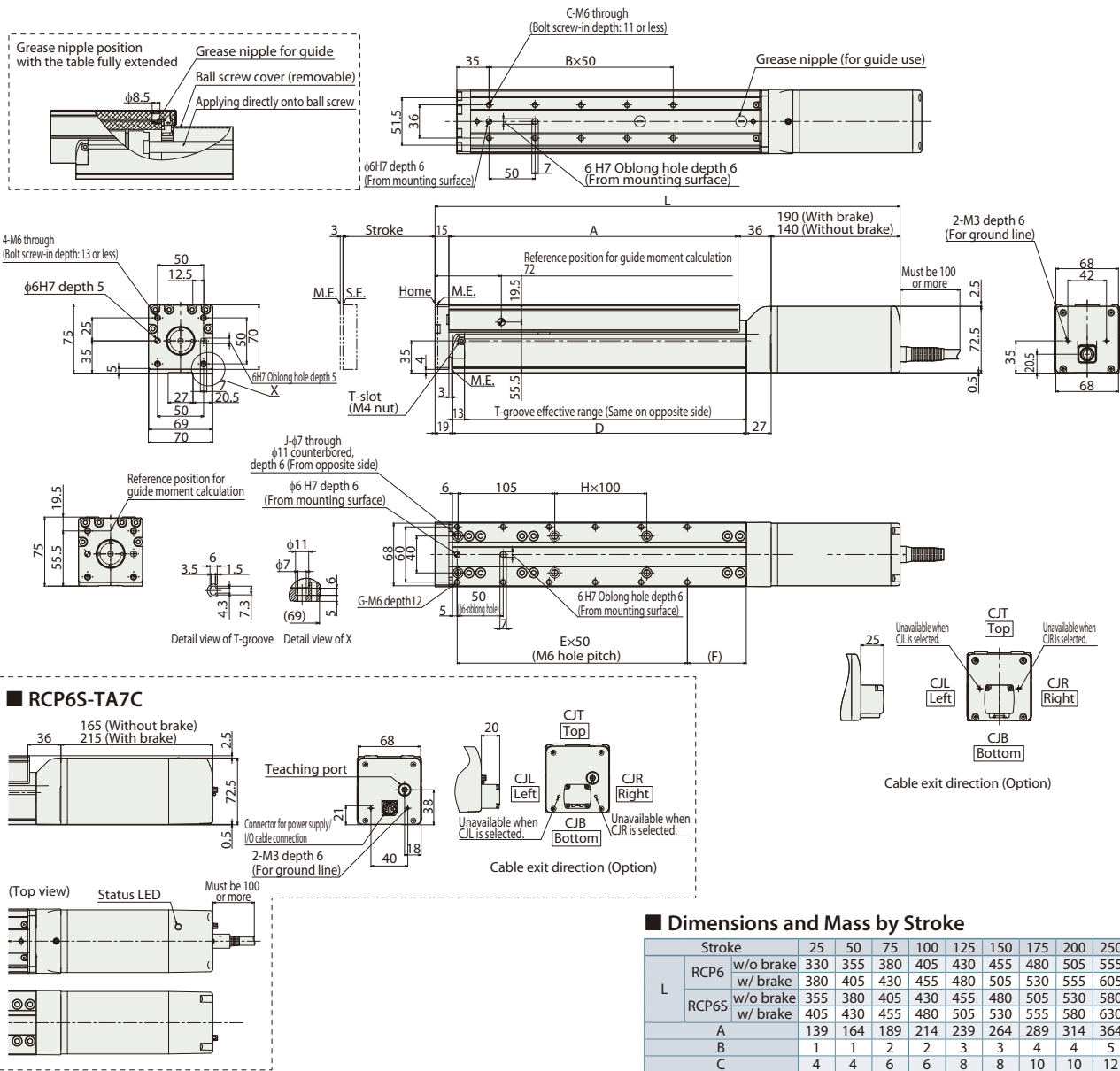

■ Dimensions and Mass by Stroke

Stroke		25	50	75	100	125	150	175	200	250	300	
L	RCP6	w/o brake	330	355	380	405	430	455	480	505	555	605
	RCP6	w/ brake	380	405	430	455	480	505	530	555	605	655
	RCP6S	w/o brake	355	380	405	430	455	480	505	530	580	630
	RCP6S	w/ brake	405	430	455	480	505	530	555	580	630	680
A			139	164	189	214	239	264	289	314	364	414
B			1	1	2	2	3	3	4	4	5	6
C			4	4	6	6	8	8	10	10	12	14
D			144	169	194	219	244	269	294	319	369	419
E			2	2	3	3	4	4	5	5	6	7
F			39	64	39	64	39	64	39	64	64	64
G			6	6	8	8	10	10	12	12	14	16
H			0	0	0	0	1	1	1	1	2	2
J			4	4	4	4	6	6	6	6	8	8
Mass (kg)	RCP6	w/o brake	3.9	4.1	4.3	4.5	4.7	5.0	5.2	5.4	5.8	6.3
		w/ brake	4.3	4.5	4.7	5.0	5.2	5.4	5.6	5.8	6.3	6.7
	RCP6S	w/o brake	4.0	4.3	4.5	4.7	4.9	5.1	5.3	5.6	6.0	6.4
		w/ brake	4.5	4.7	4.9	5.1	5.3	5.6	5.8	6.0	6.4	6.9

② Applicable Controllers

The RCP6 series actuators can be operated by the controllers indicated below. Please select the type depending on your intended use. * Please refer to P.271 for more information about the built-in controller of RCP6S series.

Name	External view	Max. number of controlled axes	Input power	Control method				Maximum number of positioning points	Reference page
				Positioner	Pulse train	Program	Network * Option		
PCON-CYB/PLB/POB		1	DC24V	●	●	—	Network cannot be selected	64	Please contact IAI for more information.
PCON-CB/CGB		1		* Option	* Option	—	DeviceNet MECHATROLINK CC-Link EtherCAT EtherNet/IP CANopen CompoNet	512 (768 for network spec.)	Please see P.255
MCON-C/CG		8		This model is network-compatible only.				256	Please contact IAI for more information.
MCON-LC/LCG		6		—	—	●	Note: The type of compatible networks will vary depending on the controller. Please refer to reference page for more information.	256	Please contact IAI for more information.
MSEL-PC/PG		4	Single-phase 100 ~ 230 VAC	—	—	●	30,000	Please contact IAI for more information.	
RCM-P6PC		1		Usable within the RCP6S Gateway system.				768	Please see P.279

* For the MCON controller, high-output enabled operation is only available if "high-output setting" is selected as an option. The maximum connectable axes with high-output enabled are C: 4 and LC: 3.

Foreword
Slider Type
Wide Slider Type
Rod Type
Radial Cylinder
Wide Radial Cylinder
Table Type
Cleanroom Slider
Cleanroom Wide Slider
Dust/Splash-Proof Rod
Dust/Splash-Proof Radial Cylinder
Dust/Splash-Proof Wide Radial Cylinder
Options
Reference Data
Controller

RCP6(S)-TA7C <Double Block Specification>

Battery-less Absolute
Motor Unit Type
Coupled Motor
Body Width 70 mm
24v Stepper Motor

Model Specification Items	Series	Type	Encoder Type	Motor Type	Lead	Stroke	Applicable Controller/I/O Type	Cable Length	Options
	TA7C	WA	56P						DB
	RCP6: Separate Controller RCP6S: Built-in Controller	WA: Battery-less Absolute	56P: Stepper Motor 56□ Size	16 :16mm 8 : 8mm 4 : 4mm	40:40mm 390:390mm	[RCP6] P3 : PCON MCON MSEL P5 : RCM-P6PC [RCP6S] SE: SIO Type	N : None P : 1m S : 3m M : 5m XC□□ : Specified Length R□□ : Robot Cable	Please refer to the options table below. *Model number symbols should be written in alphabetical order, including "DB".	

* RCP6 does not include a controller. RCP6S includes a built-in controller.
* Please refer to P.17 for more information about the model specification items.

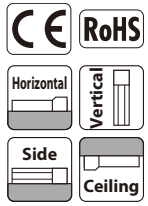

*Some limitations may apply to horizontal/side/ceiling mountings depending on the model. See page 204. Please contact IAI for more information.



POINT Selection Notes

- (1) The maximum acceleration/deceleration is 1G for horizontal, and 0.5G for vertical use.
- (2) The actuator specifications displays the payload's maximum value, but it will vary depending on the acceleration and speed. Please refer to the "Selection Guidelines" (Tables of Payload by Speed/Acceleration) on P.228 for more details.
- (3) Please refer to P.205 for performing push-motion operation.
- (4) Depending on the ambient operating temperature, duty control is necessary for the RCP6S (built-in controller type) with lead 4/8/16. Please refer to P.247 for more information.

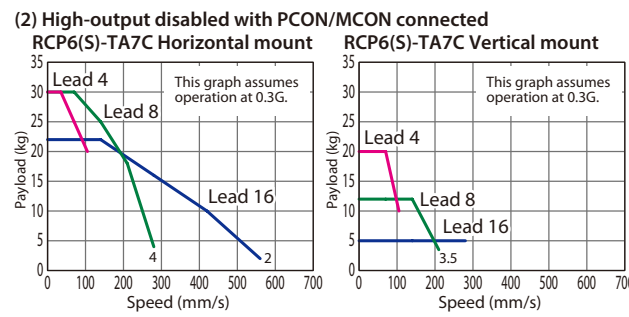
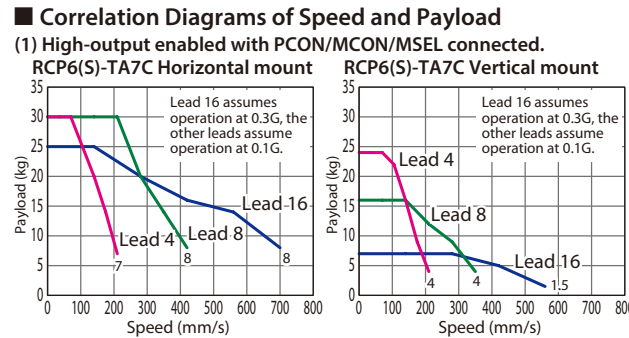

Actuator Specifications													
Lead and Payload			Stroke and Max Speed										
Model Number	Lead (mm)	Connected Controller	Max. Payload		Max. Push Force (N)*	Stroke (mm)	Lead (mm)	Connected Controller	40~290 (mm)			340 (mm)	390 (mm)
			Horizontal (kg)	Vertical (kg)					700<560>	560<280>	300		
RCP6(S)-TA7C-WA-56P-16-①-②-③-DB-④	16	High-output Enabled	25	7	168	40~390	16	High-output Enabled	700<560>		600<560>		
		High-output Disabled	22	5				High-output Disabled	560<280>				
RCP6(S)-TA7C-WA-56P-8-①-②-③-DB-④	8	High-output Enabled	30	16	336	8	High-output Enabled	420<350>	365<350>	300			
		High-output Disabled		12			High-output Disabled	280<210>					
RCP6(S)-TA7C-WA-56P-4-①-②-③-DB-④	4	High-output Enabled	30	24	673	4	High-output Enabled	210	180	150			
		High-output Disabled		20			High-output Disabled	105					

Legend: ① Stroke ② Applicable controllers/I/O type ③ Cable length ④ Options

* Push force only available during push mode w / limited speed. Values in brackets <> are for vertical use.

① Stroke

Stroke (mm)	RCP6	RCP6S
40	○	○
65	○	○
90	○	○
140	○	○
190	○	○
240	○	○
290	○	○
340	○	○
390	○	○

③ Cable Length

Cable Type	Cable Code	RCP6			RCP6S
		P3	P5	SE	
Standard	P(1m)	○	○	○	
	S(3m)	○	○	○	
	M(5m)	○	○	○	
	M(5m)	○	○	○	
Specified length	X06 (6m) ~X10 (10m)	○	○	○	
	X11 (11m) ~X15 (15m)	○	○	○	
	X16 (16m) ~X20 (20m)	○	○	○	
	X21 (21m) ~X25 (25m)	○	○	○	
Robot cable	R01 (1m) ~R03 (3m)	○	○	○	
	R04 (4m) ~R05 (5m)	○	○	○	
	R06 (6m) ~R10 (10m)	○	○	○	
	R11 (11m) ~R15 (15m)	○	○	○	
	R16 (16m) ~R20 (20m)	○	○	○	
	R21 (21m) ~R25 (25m)	○	○	○	

* Please refer to P. 267 and 283 for more information regarding the maintenance cables.

④ Options

Name	Option Code	Reference Page
Brake	B	See P.189
Cable exit direction (Top)	CJT	See P.189
Cable exit direction (Right)	CJR	See P.189
Cable exit direction (Left)	CJL	See P.189
Cable exit direction (Bottom)	CJB	See P.189
Non-motor end specification	NM	See P.194

Actuator Specifications

Item	Description
Drive system	Ball screw φ12mm, rolled C10
Positioning repeatability	±0.01mm
Lost motion	0.1mm or less
Base	Material: Aluminum with white alumite treatment
Static allowable moment	Ma: 620N·m, Mb: 620N·m, Mc: 458N·m
Dynamic allowable moment (*)	Ma: 196N·m, Mb: 196N·m, Mc: 145N·m
Ambient operating temp. & humidity	0~40°C, 85% RH or less (Non-condensing)

(*) Assumes a standard rated life of 5,000km. The service life will vary depending on operation and installation conditions.
Please refer to our website for more information regarding the directions of the allowable moment and overhang load length.
Please refer to RCP6 instruction manual regarding the displacement of the table.



*1 When the table is returning to its home position, please be careful of interference from surrounding objects, as it will travel until it reaches the M.E.
M.E: Mechanical end S.E: Stroke end

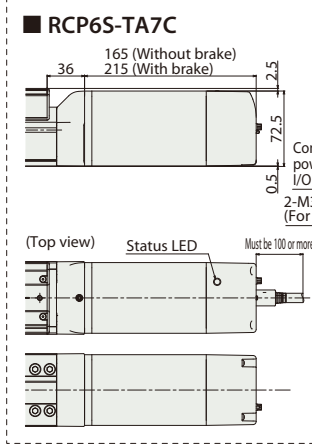
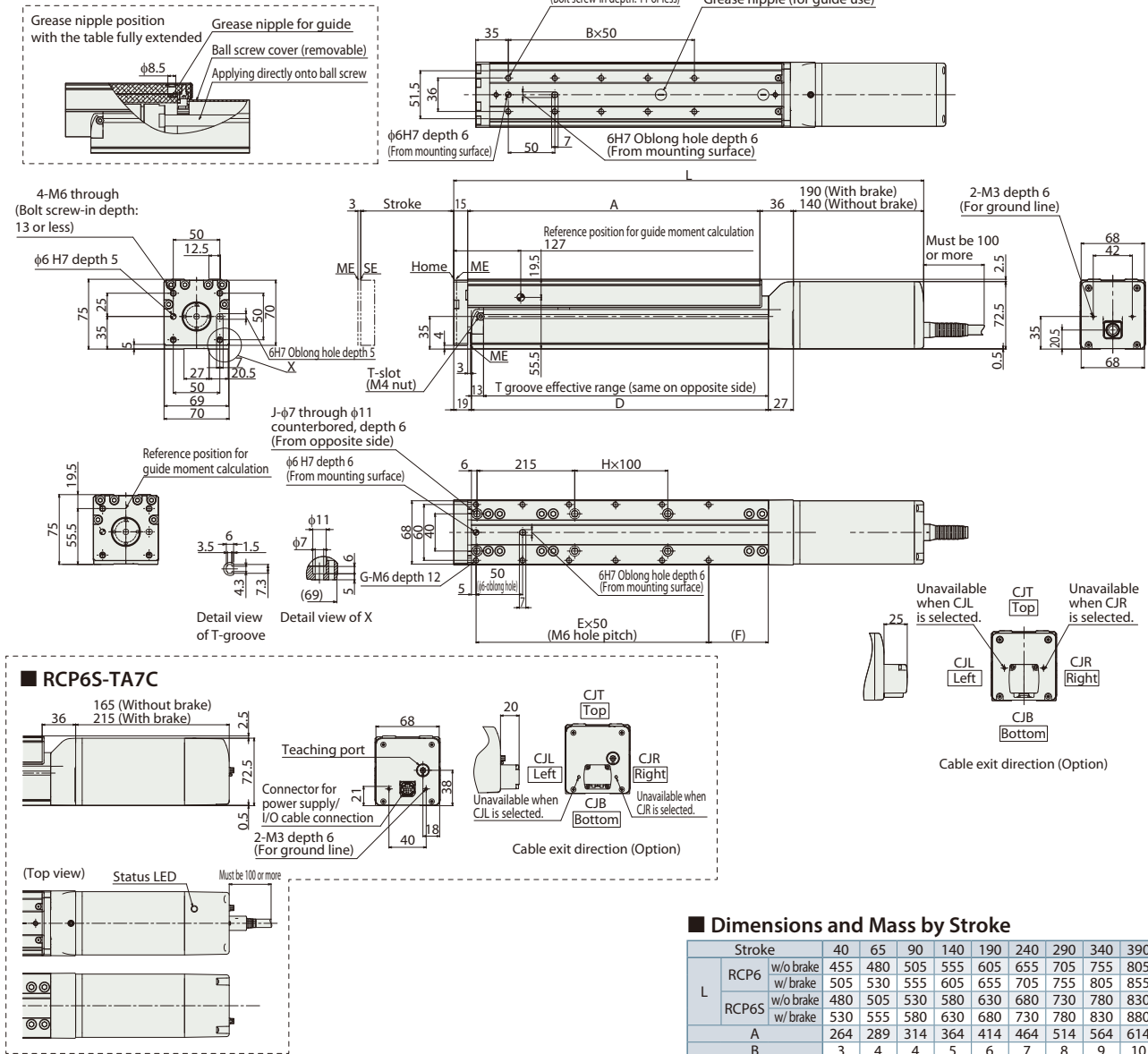

■ Dimensions and Mass by Stroke

L	Stroke	40	65	90	140	190	240	290	340	390
		RCP6 w/o brake	455	480	505	555	605	655	705	755
RCP6S w/o brake	505	530	555	605	655	705	755	805	855	
RCP6S w/brake	480	505	530	580	630	680	730	780	830	
A	264	289	314	364	414	464	514	564	614	
B	3	4	4	5	6	7	8	9	10	
C	8	10	10	12	14	16	18	20	22	
D	269	294	319	369	419	469	519	569	619	
E	4	5	5	6	7	8	9	10	11	
F	64	39	64	64	64	64	64	64	64	
G	10	12	12	14	16	18	20	22	24	
H	0	0	0	1	1	2	2	3	3	
J	4	4	4	6	6	8	8	10	10	
Mass (kg)	RCP6 w/o brake	5.3	5.6	5.8	6.2	6.6	7.1	7.5	8.0	8.4
	RCP6S w/o brake	5.5	5.7	5.9	6.4	6.8	7.3	7.7	8.1	8.6
	RCP6S w/brake	5.5	5.7	5.9	6.4	6.8	7.3	7.7	8.1	8.6
	RCP6S w/brake	5.9	6.2	6.4	6.8	7.3	7.7	8.1	8.6	9.0

② Applicable Controllers

The RCP6 series actuators can be operated by the controllers indicated below. Please select the type depending on your intended use. * Please refer to P.271 for more information about the built-in controller of RCP6S series.

Name	External view	Max. number of controlled axes	Input power	Control method				Maximum number of positioning points	Reference page
				Positioner	Pulse train	Program	Network * Option		
PCON-CYB/PLB/POB		1	DC24V	●	●	—	Network cannot be selected	64	Please contact IAI for more information.
PCON-CB/CGB		1		* Option	* Option	—	DeviceNet MECHATROLINK EtherCAT EtherNet/IP	512 (768 for network spec.)	Please see P.255
MCON-C/CG		8		This model is network-compatible only.				CompoNet SSCNETIII/H	256
MCON-LC/LCG		6		—	—	●	256		Please contact IAI for more information.
MSEL-PC/PG		4	Single-phase 100 ~ 230 VAC	—	—	●	30,000	Please contact IAI for more information.	
RCM-P6PC		1	Usable within the RCP6S Gateway system.				768	Please see P.279	

* For the MCON controller, high-output enabled operation is only available if "high-output setting" is selected as an option. The maximum connectable axes with high-output enabled are C: 4 and LC: 3.

Foreword
Slider Type
Wide Slider Type
Rod Type
Radial Cylinder
Wide Radial Cylinder
Table Type
Cleanroom Slider
Cleanroom Wide Slider
Dust/Splash-Proof Rod
Dust/Splash-Proof Radial Cylinder
Dust/Splash-Proof Wide Radial Cylinder
Options
Reference Data
Controller

RCP6(S)-TA4R <Single Block Specifications>

Battery-less Absolute

Motor Unit Type

Side-mounted Motor

Body Width 40mm*

24v Stepper Motor

Model Specification Items

Series	Type	Encoder Type	Motor Type	Lead	Stroke	Applicable Controller/I/O Type	Cable Length	Options
RCP6: Separate Controller RCP6S: Built-in Controller	TA4R	WA	35P	16: 16mm 10: 10mm 5: 5mm 2.5: 2.5mm	25: 25mm 150: 150mm (25mm increments)	[RCP6] P3: PCON MCON MSEL P5: RCM-P6PC [RCP6S] SE: SIO Type	N: None P: 1m S: 3m M: 5m X□□: Specified Length R□□: Robot Cable	Please refer to the options table below. * Please make sure to specify either ML or MR when ordering the side-mounted motor type.

* RCP6 does not include a controller. RCP6S includes a built-in controller.
* Please refer to P.17 for more information about the model specification items.

* Body width does not include the width of the side-mounted motor.

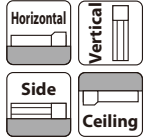

*Some limitations may apply to horizontal/side/ceiling mountings depending on the model. See page 204. Please contact IAI for more information.



The figure above is the motor side-mounted to the left (ML).



- (1) The maximum acceleration/deceleration is 1G for horizontal, and 0.5G for vertical use.
- (2) The actuator specification displays the payload's maximum value, but it will vary depending on the acceleration and speed. Please refer to the "Selection Guidelines" (Tables of Payload by Speed/Acceleration) on P.229 for more details.
- (3) Please refer to P205 for performing push-motion operation.

Correlation Diagrams of Speed and Payload

(1) High-output enabled with PCON/MCON/MSEL connected.

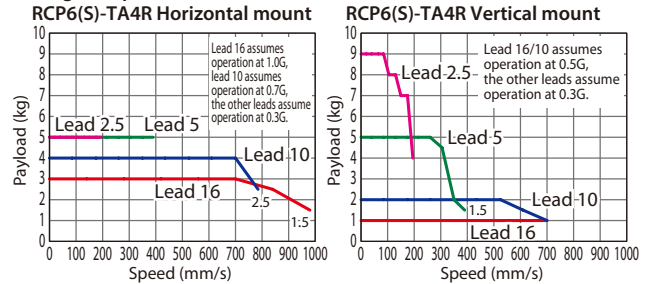

(2) High-output disabled with PCON/MCON connected.

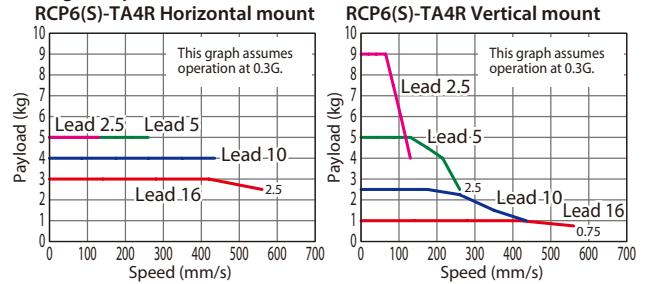

Actuator Specifications

Lead and Payload

* Push force only available during push mode w / limited speed.

Model Number	Lead (mm)	Connected Controller	Max. Payload		Stroke (mm)
			Horizontal (kg)	Vertical (kg)	
RCP6(S)-TA4R-WA-35P-16-①②③④	16	High-output Enabled	3	1	25~150 (The increment of stroke is 25mm)
		High-output Disabled			
RCP6(S)-TA4R-WA-35P-10-①②③④	10	High-output Enabled	4	2.5	25~150 (The increment of stroke is 25mm)
		High-output Disabled			
RCP6(S)-TA4R-WA-35P-5-①②③④	5	High-output Enabled	5	5	25~150 (The increment of stroke is 25mm)
		High-output Disabled			
RCP6(S)-TA4R-WA-35P-2.5-①②③④	2.5	High-output Enabled	5	10	25~150 (The increment of stroke is 25mm)
		High-output Disabled		9	

Legend: ① Stroke ② Applicable controller/I/O type ③ Cable length ④ Options

Stroke and Max. Speed

(Unit: mm/s)

Lead (mm)	Connected Controller	25~150 (mm)
16	High-output Enabled	980 <700>
	High-output Disabled	840 <560>
10	High-output Enabled	785 <700>
	High-output Disabled	525 <435>
5	High-output Enabled	390
	High-output Disabled	260
2.5	High-output Enabled	195
	High-output Disabled	130

Values in brackets < > are for vertical use.

① Stroke

Stroke (mm)	RCP6	RCP6S
25	○	○
50	○	○
75	○	○
100	○	○
125	○	○
150	○	○

④ Options

Name	Option Code	Reference Page
Brake	B	See P.189
Cable exit direction (Outside)	CJO	See P.189
Motor side-mounted to the left	ML	See P.193
Motor side-mounted to the right	MR	See P.193
Non-motor end specification	NM	See P.194

When selecting multiple options, please list them in alphabetical order. (e.g. B-CJB-NM)

③ Cable Length

Cable Type	Cable Code	RCP6			RCP6S
		P3	P5	SE	
Standard	P (1m)	○	○	○	○
	S (3m)	○	○	○	○
	M (5m)	○	○	○	○
Specified Length	X06 (6m) ~X10 (10m)	○	○	○	○
	X11 (11m) ~X15 (15m)	○	○	○	○
	X16 (16m) ~X20 (20m)	○	○	○	○
	R01 (1m) ~R03 (3m)	○	○	○	○
Robot Cable	R04 (4m) ~R05 (5m)	○	○	○	○
	R06 (6m) ~R10 (10m)	○	○	○	○
	R11 (11m) ~R15 (15m)	○	○	○	○
	R16 (16m) ~R20 (20m)	○	○	○	○

* Please refer to P.267 and 283 for more information regarding the maintenance cables.

Actuator Specifications

Item	Description
Drive system	Ball screw φ8mm, rolled C10
Positioning repeatability	±0.01mm
Lost motion	0.1mm or less
Base	Material: Aluminum with white alumite treatment
Static allowable moment	Ma: 13N·m, Mb: 18.6N·m, Mc: 25.3N·m
Dynamic allowable moment (*)	Ma: 4.98N·m, Mb: 7.11N·m, Mc: 9.68N·m
Ambient operating temp. & humidity	0~40°C, 85% RH or less (Non-condensing)

(*) Assumes a standard rated life of 5,000km. The service life will vary depending on operation and installation conditions.

Please refer to our website for more information regarding the directions of the allowable moment and overhang load length.

Please refer to RCP6 instruction manual regarding the displacement of the table.



*1 When the table is returning to its home position, please be careful of interference from surrounding objects, as it will travel until it reaches the M.E.
M.E: Mechanical end
S.E: Stroke end

*2 For the single block type with 25~75mm strokes, tools cannot be used on the $\phi 5$ front mounting holes on the top surface because the motor unit interferes. Please use the mounting screw holes on the bottom surface. (Same for the RCP6S)

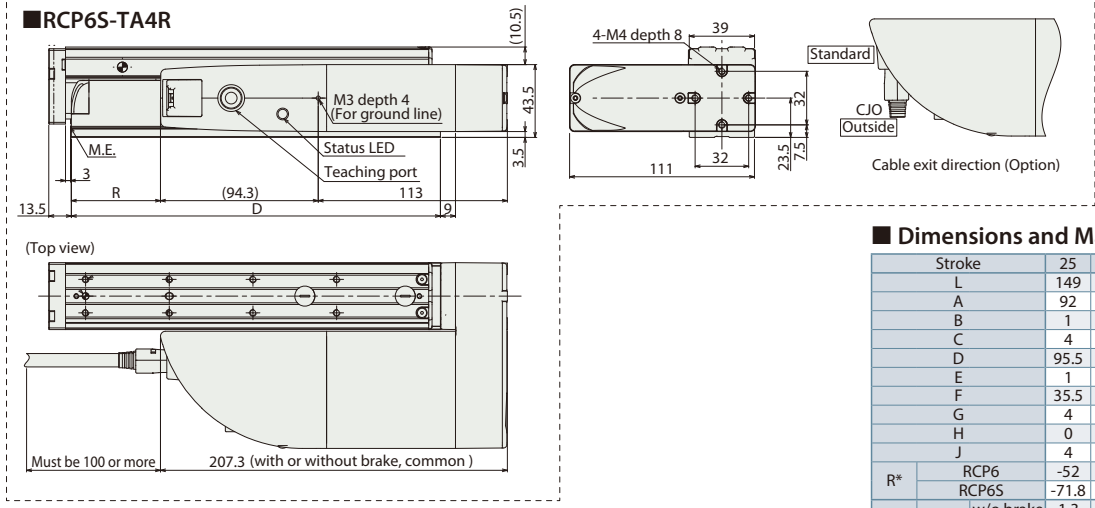
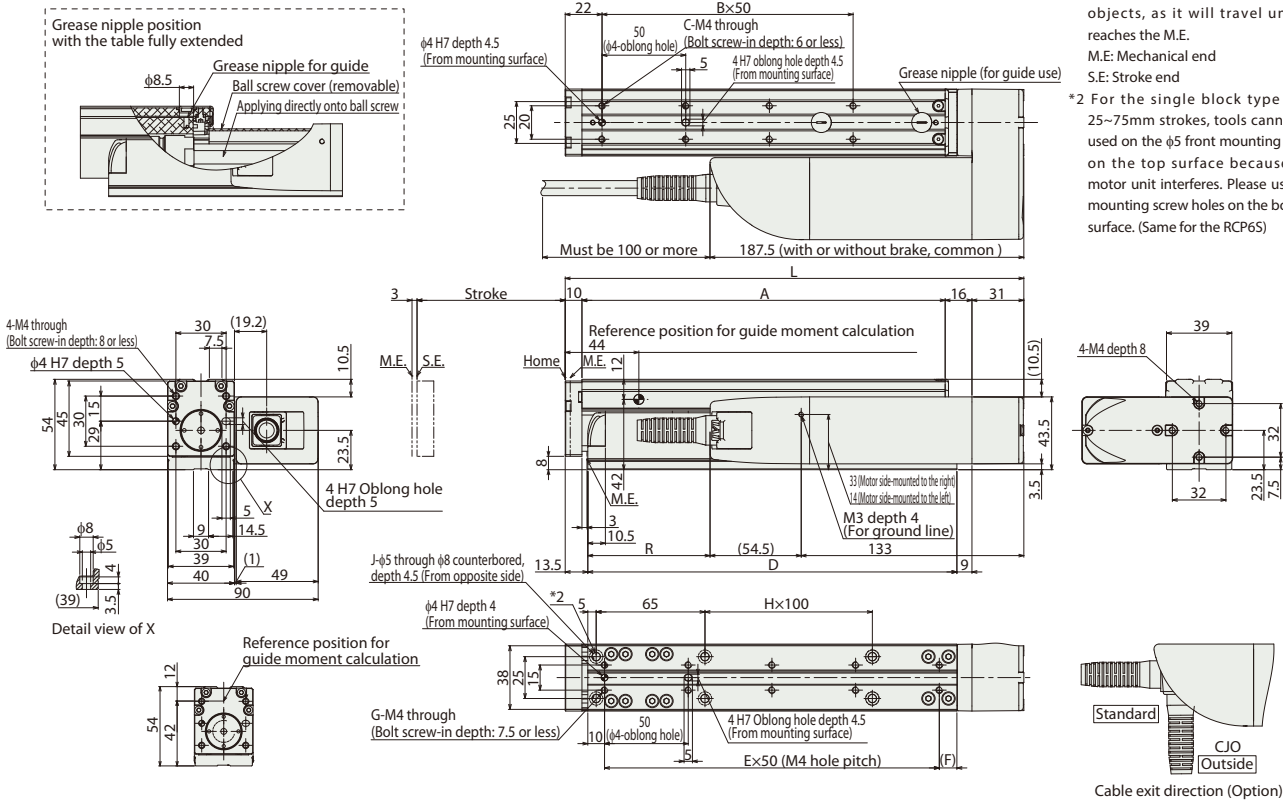

■ Dimensions and Mass by Stroke

Stroke	25	50	75	100	125	150		
L	149	174	199	224	249	274		
A	92	117	142	167	192	217		
B	1	1	2	2	3	3		
C	4	4	6	6	8	8		
D	95.5	120.5	145.5	170.5	195.5	220.5		
E	1	2	2	3	3	4		
F	35.5	10.5	35.5	10.5	35.5	10.5		
G	4	6	6	8	8	10		
H	0	0	0	0	1	1		
J	4	4	4	4	6	6		
R*	RCP6	-52	-27	-2	23	48		
	RCP6S	-71.8	-46.8	-21.8	3.2	28.2		
Mass (kg)	RCP6	w/o brake	1.3	1.4	1.5	1.6	1.7	1.8
		w/ brake	1.4	1.5	1.6	1.7	1.8	1.8
	RCP6S	w/o brake	1.5	1.6	1.6	1.7	1.8	1.9
		w/ brake	1.5	1.6	1.7	1.8	1.9	2.0

* If the length for R is negative in the table below, the length of the actuator body is shorter than the motor unit.

② Applicable Controllers

The RCP6 series actuators can be operated by the controllers indicated below. Please select the type depending on your intended use. * Please refer to P.271 for more information about the built-in controller of RCP6S series.

Name	External view	Max. number of controlled axes	Input power	Control method				Maximum number of positioning points	Reference page
				Positioner	Pulse train	Program	Network * Option		
PCON-CYB/PLB/POB		1	DC24V	●	●	-	Network cannot be selected	64	Please contact IAI for more information.
PCON-CB/CGB		1		* Option	* Option	-	DeviceNet MECHATROLINK CC-Link EtherCAT EtherNet/IP PROFINET CompoNet	512 (768 for network spec.)	Please see P.255
MCON-C/CG		8		This model is network-compatible only.				256	Please contact IAI for more information.
MCON-LC/LCG		6		-	-	●	Note: The type of compatible networks will vary depending on the controller. Please refer to reference page for more information.	256	Please contact IAI for more information.
MSEL-PC/PG		4	Single-phase 100 ~ 230 VAC	-	-	●	30,000	Please contact IAI for more information.	
RCM-P6PC		1	Usable within the RCP6S Gateway system.				768	Please see P.279	

* For the MCON controller, high-output enabled operation is only available if "high-output setting" is selected as an option. The maximum connectable axes with high-output enabled are C: 4 and LC: 3.

Foreword
Slider Type
Wide Slider Type
Rod Type
Radial Cylinder
Wide Radial Cylinder
Table Type
Cleanroom Slider
Cleanroom Wide Slider
Dust/Splash-Proof Rod
Dust/Splash-Proof Radial Cylinder
Dust/Splash-Proof Wide Radial Cylinder
Options
Reference Data
Controller

RCP6(S)-TA4R <Double Block Specification>

Battery-less Absolute Motor Unit Type Side-mounted Motor Body Width 40mm Stepper Motor 24v

Model Specification Items	Series	Type	Encoder Type	Motor Type	Lead	Stroke	Applicable Controller/I/O Type	Cable Length	Options
		TA4R	WA	35P					DB
	RCP6: Separate Controller RCP6S: Built-in Controller		WA: Battery-less Absolute	35P: Stepper Motor 35□ Size	10 : 10mm 5 : 5mm 2.5 : 2.5mm	40:40mm 240:240mm	[RCP6] P3 : PCON MCON MSEL P5 : RCM-P6PC [RCP6S] SE: SIO Type	N : None P : 1m S : 3m M : 5m XC□ : Specified Length R□□ : Robot Cable	Please refer to the options table below. *Model number symbols should be written in alphabetical order, including "DB".

* RCP6 does not include a controller. RCP6S includes a built-in controller.
* Please refer to P.17 for more information about the model specification items.

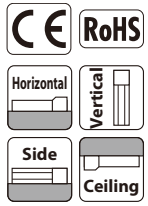

*Some limitations may apply to horizontal/side/ceiling mountings depending on the model. See page 204. Please contact IAI for more information.

The figure above is the motor side-mounted to left (ML).

POINT Selection Notes

- (1) The maximum acceleration/deceleration is 1G for horizontal, and 0.5G for vertical use.
- (2) The actuator specifications displays the payload's maximum value, but it will vary depending on the acceleration and speed. Please refer to the "Selection Guidelines" (Tables of Payload by Speed/Acceleration) on P.230 for more details.
- (3) Please refer to P205 for performing push-motion operation.

Correlation Diagrams of Speed and Payload

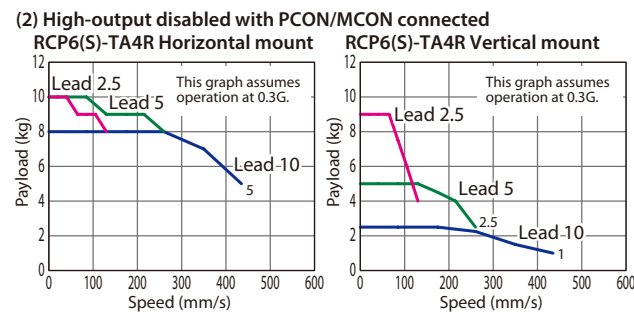
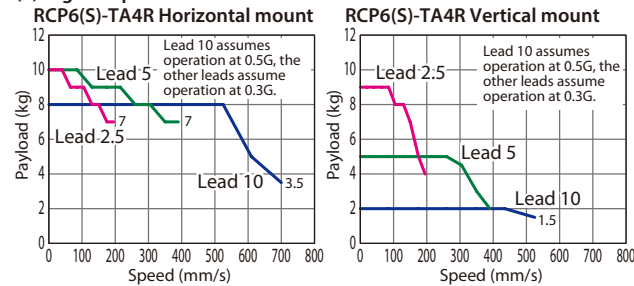

Actuator Specifications

Model Number	Lead (mm)	Connected Controller	* Push force only available during push mode w / limited speed.			Stroke and Max Speed (Unit: mm/s)		
			Max. Payload Horizontal (kg)	Max. Payload Vertical (kg)	Max. Push Force (N)*	Stroke (mm)	40~190 (mm)	240 (mm)
RCP6(S)-TA4R-WA-35P-10-①-②-③-DB-④	10	High-output Enabled	8	2.5	77	40~240	700<525>	680<525>
		High-output Disabled					525<435>	
RCP6(S)-TA4R-WA-35P-5-①-②-③-DB-④	5	High-output Enabled	10	5	155	40~240	390	340
		High-output Disabled					260	
RCP6(S)-TA4R-WA-35P-2.5-①-②-③-DB-④	2.5	High-output Enabled	10	10	310	40~240	195	170
		High-output Disabled	9				130	

Legend: ① Stroke ② Applicable controllers/I/O type ③ Cable length ④ Options

Values in brackets < > are for vertical use.

① Stroke

Stroke (mm)	RCP6	RCP6S
40	○	○
65	○	○
90	○	○
140	○	○
190	○	○
240	○	○

④ Options

Name	Option Code	Reference Page
Brake	B	See P.189
Cable exit direction (Outside)	CJO	See P.189
Motor side-mounted to the left	ML	See P.193
Motor side-mounted to the right	MR	See P.193
Non-motor end specification	NM	See P.194

③ Cable Length

Cable Type	Cable Code	RCP6			RCP6S
		P3	P5	SE	
Standard	P(1m)	○	○	○	
	S(3m)	○	○	○	
	M(5m)	○	○	○	
Specified length	X06 (6m) ~X10 (10m)	○	○	○	
	X11 (11m) ~X15 (15m)	○	○	○	
	X16 (16m) ~X20 (20m)	○	○	○	
	R01 (1m) ~R03 (3m)	○	○	○	
Robot cable	R04 (4m) ~R05 (5m)	○	○	○	
	R06 (6m) ~R10 (10m)	○	○	○	
	R11 (11m) ~R15 (15m)	○	○	○	
	R16 (16m) ~R20 (20m)	○	○	○	

* Please refer to P. 267 and 283 for more information regarding the maintenance cables.

Actuator Specifications

Item	Description
Drive system	Ball screw φ8mm, rolled C10
Positioning repeatability	±0.01mm
Lost motion	0.1mm or less
Base	Material: Aluminum with white alumite treatment
Static allowable moment	Ma: 76.8N·m, Mb: 110N·m, Mc: 50.5N·m
Dynamic allowable moment (*)	Ma: 23.9N·m, Mb: 34.1N·m, Mc: 15.7N·m
Ambient operating temp. & humidity	0~40°C, 85% RH or less (Non-condensing)

(*) Assumes a standard rated life of 5,000km. The service life will vary depending on operation and installation conditions.

Please refer to our website for more information regarding the directions of the allowable moment and overhang load length.
Please refer to RCP6 instruction manual regarding the displacement of the table.

RCP6(S)-TA6R <Single Block Specifications>

Battery-less Absolute

Motor Unit Type

Side-mounted Motor

Body Width 58* mm

24v Stepper Motor

Model Specification Items

Series — **TA6R** — Type — **WA** — Encoder Type — **42P** — Lead — Stroke — Applicable Controller/I/O Type — Cable Length — Options

RCP6: Separate Controller
RCP6S: Built-in Controller

WA: Battery-less Absolute

42P: Stepper Motor 42□ Size

20: 20mm
12: 12mm
6: 6mm
3: 3mm

25: 25mm
200: 200mm (25mm increments)

[RCP6]
P3: PCON
MCON
MSEL
P5: RCM-P6PC
[RCP6S]
SE: SIO Type

N: None
P: 1m
S: 3m
M: 5m
X□□: Specified Length
R□□: Robot Cable

Please refer to the options table below.
* Please make sure to specify either ML or MR when ordering the side-mounted motor type.

* Body width does not include the width of the side-mounted motor.

* RCP6 does not include a controller. RCP6S includes a built-in controller.
* Please refer to P.17 for more information about the model specification items.

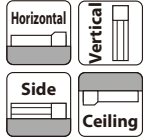

*Some limitations may apply to horizontal/side/ceiling mountings depending on the model. See page 204. Please contact IAI for more information.



The figure above is the motor side-mounted to the left (ML).



- (1) The maximum acceleration/deceleration is 1G for horizontal, and 0.5G for vertical use.
- (2) The actuator specification displays the payload's maximum value, but it will vary depending on the acceleration and speed. Please refer to the "Selection Guidelines" (Tables of Payload by Speed/Acceleration) on P.229 for more details.
- (3) Please refer to P.205 for performing push-motion operation.
- (4) Depending on the ambient operational temperature, duty control is necessary for the RCP6S (built-in controller type) with lead 3/6. Please refer to P.247 for more information.

Correlation Diagrams of Speed and Payload

(1) High-output enabled with PCON/MCON/MSEL connected.

RCP6(S)-TA6R Horizontal mount

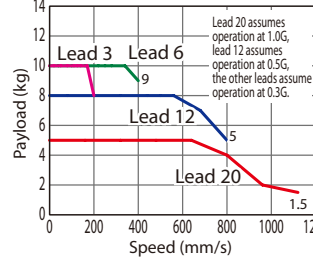

RCP6(S)-TA6R Vertical mount

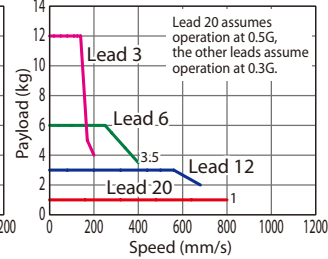

(2) High-output disabled with PCON/MCON connected.

RCP6(S)-TA6R Horizontal mount

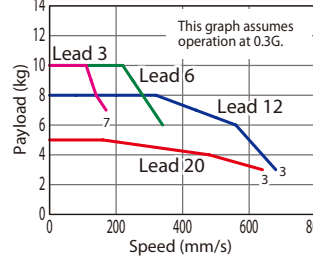

RCP6(S)-TA6R Vertical mount

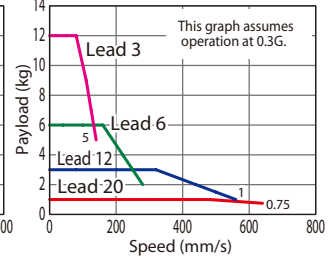

Actuator Specifications

Lead and Payload

* Push force only available during push mode w / limited speed.

Model Number	Lead (mm)	Connected Controller	Max. Payload		Stroke (mm)
			Horizontal (kg)	Vertical (kg)	
RCP6(S)-TA6R-WA-42P-20-①-②-③-④	20	High-output Enabled	5	1	25~200 (The increment of stroke is 25mm)
		High-output Disabled	5	1	
RCP6(S)-TA6R-WA-42P-12-①-②-③-④	12	High-output Enabled	8	3	
		High-output Disabled	8	3	
RCP6(S)-TA6R-WA-42P-6-①-②-③-④	6	High-output Enabled	10	6	
		High-output Disabled	10	6	
RCP6(S)-TA6R-WA-42P-3-①-②-③-④	3	High-output Enabled	10	12	
		High-output Disabled	10	12	

Legend: ① Stroke ② Applicable controller/I/O type ③ Cable length ④ Options

Stroke and Max. Speed

(Unit: mm/s)

Lead (mm)	Connected Controller	25~200 (mm)	
		Horizontal	Vertical
20	High-output Enabled	1,120	<800>
	High-output Disabled	800	<640>
12	High-output Enabled	800	<680>
	High-output Disabled	680	<560>
6	High-output Enabled	400	
	High-output Disabled	340	<280>
3	High-output Enabled	200	
	High-output Disabled	170	<140>

Values in brackets < > are for vertical use.

① Stroke

Stroke (mm)	RCP6	RCP6S
25	○	○
50	○	○
75	○	○
100	○	○
125	○	○
150	○	○
175	○	○
200	○	○

③ Cable Length

Cable Type	Cable Code	RCP6			RCP6S
		P3	P5	SE	
Standard	P (1m)	○	○	○	○
	S (3m)	○	○	○	○
	M (5m)	○	○	○	○
	X06 (6m) ~X10 (10m)	○	○	○	○
Specified Length	X11 (11m) ~X15 (15m)	○	○	○	○
	X16 (16m) ~X20 (20m)	○	○	○	○
	R01 (1m) ~R03 (3m)	○	○	○	○
Robot Cable	R04 (4m) ~R05 (5m)	○	○	○	○
	R06 (6m) ~R10 (10m)	○	○	○	○
	R11 (11m) ~R15 (15m)	○	○	○	○
	R16 (16m) ~R20 (20m)	○	○	○	○
		○	○	○	○
		○	○	○	○

* Please refer to P.267 and 283 for more information regarding the maintenance cables.

④ Options

Name	Option Code	Reference Page
Brake	B	See P.189
Cable exit direction (Outside)	CJO	See P.189
Motor side-mounted to the left	ML	See P.193
Motor side-mounted to the right	MR	See P.193
Non-motor end specification	NM	See P.194

When selecting multiple options, please list them in alphabetical order. (e.g. B-CJB-NM)

Actuator Specifications

Item	Description
Drive system	Ball screw φ10mm, rolled C10
Positioning repeatability	±0.01mm
Lost motion	0.1mm or less
Base	Material: Aluminum with white alumite treatment
Static allowable moment	Ma: 32.3N·m, Mb: 46.2N·m, Mc: 68.3N·m
Dynamic allowable moment (*)	Ma: 11.6N·m, Mb: 16.6N·m, Mc: 24.6N·m
Ambient operating temp. & humidity	0~40°C, 85% RH or less (Non-condensing)

(*) Assumes a standard rated life of 5,000km. The service life will vary depending on operation and installation conditions.

Please refer to our website for more information regarding the directions of the allowable moment and overhang load length.

Please refer to RCP6 instruction manual regarding the displacement of the table.

RCP6(S)-TA6R <Double Block Specification>

Battery-less Absolute

Motor Unit Type

Side-mounted Motor

Body Width 58 mm*

24v Stepper Motor

Model Specification Items

Series — **TA6R** — Type — **WA** — Encoder Type — **42P** — Lead — Stroke — Applicable Controller/I/O Type — Cable Length — Options — **DB**

RCP6: Separate Controller
RCP6S: Built-in Controller

WA: Battery-less Absolute
42P: Stepper Motor 42□ Size

Lead: 12: 12mm, 6: 6mm, 3: 3mm
Stroke: 45: 45mm, 320: 320mm

[RCP6]
P3: PCON, MCON, MSEL
P5: RCM-P6PC [RCP6S]
SE: SIO Type

N: None
P: 1m
S: 3m
M: 5m
XC□□: Specified Length
R□□: Robot Cable

Please refer to the options table below.
*Model number symbols should be written in alphabetical order, including "DB".

*Body width does not include the width of the side-mounted motor.

* RCP6 does not include a controller. RCP6S includes a built-in controller.
* Please refer to P.17 for more information about the model specification items.

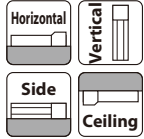

*Some limitations may apply to horizontal/side/ceiling mountings depending on the model. See page 204. Please contact IAI for more information.



The figure above is the motor side-mounted to left (ML).

POINT Selection Notes

- The maximum acceleration/deceleration is 1G for horizontal, and 0.5G for vertical use.
- The actuator specifications displays the payload's maximum value, but it will vary depending on the acceleration and speed. Please refer to the "Selection Guidelines" (Tables of Payload by Speed/Acceleration) on P.230 for more details.
- Please refer to P.205 for performing push-motion operation.
- Depending on the ambient operating temperature, duty control is necessary for the RCP6S (built-in controller type) with lead 3/6. Please refer to P.247 for more information.

Correlation Diagrams of Speed and Payload

(1) High-output enabled with PCON/MCON/MSEL connected.

RCP6(S)-TA6R Horizontal mount

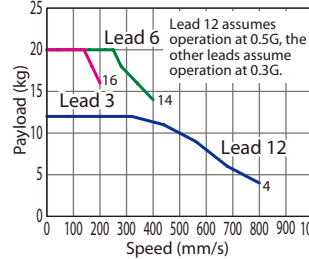

RCP6(S)-TA6R Vertical mount

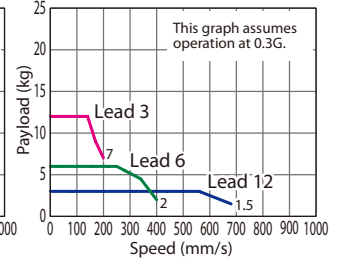

(2) High-output disabled with PCON/MCON connected

RCP6(S)-TA6R Horizontal mount

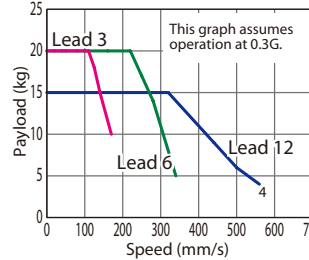

RCP6(S)-TA6R Vertical mount

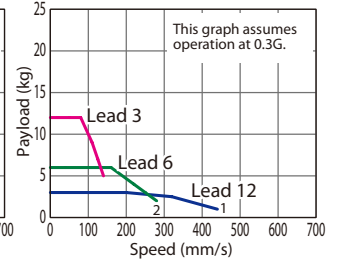

Actuator Specifications

Lead and Payload

* Push force only available during push mode w / limited speed.

Model Number	Lead (mm)	Connected Controller	Max. Payload		Max. Push Force (N)*	Stroke (mm)
			Horizontal (kg)	Vertical (kg)		
RCP6(S)-TA6R-WA-42P-12-①-②-③-DB-④	12	High-output Enabled	15	3	93	45~320
		High-output Disabled				
RCP6(S)-TA6R-WA-42P-6-①-②-③-DB-④	6	High-output Enabled	20	6	185	45~320
		High-output Disabled				
RCP6(S)-TA6R-WA-42P-3-①-②-③-DB-④	3	High-output Enabled	20	12	370	45~320
		High-output Disabled				

Legend: ① Stroke ② Applicable controllers/I/O type ③ Cable length ④ Options

Stroke and Max Speed

(Unit: mm/s)

Lead (mm)	Connected Controller	Max Speed		
		45~220 (mm)	270 (mm)	320 (mm)
12	High-output Enabled	800<680>	735<680>	575
	High-output Disabled	560<440>		
6	High-output Enabled	400	365	285
	High-output Disabled	340<280>		
3	High-output Enabled	200	185	140
	High-output Disabled	170<140>		

Values in brackets <> are for vertical use.

① Stroke

Stroke (mm)	RCP6	RCP6S
45	○	○
70	○	○
95	○	○
120	○	○
170	○	○
220	○	○
270	○	○
320	○	○

③ Cable Length

Cable Type	Cable Code	RCP6			RCP6S
		P3	P5	SE	
Standard	P(1m)	○	○	○	
	S(3m)	○	○	○	
	M(5m)	○	○	○	
	X06 (6m) ~X10 (10m)	○	○	○	
Specified length	X11 (11m) ~X15 (15m)	○	○	○	
	X16 (16m) ~X20 (20m)	○	○	○	
	R01 (1m) ~R03 (3m)	○	○	○	
Robot cable	R04 (4m) ~R05 (5m)	○	○	○	
	R06 (6m) ~R10 (10m)	○	○	○	
	R11 (11m) ~R15 (15m)	○	○	○	
	R16 (16m) ~R20 (20m)	○	○	○	

* Please refer to P. 267 and 283 for more information regarding the maintenance cables.

④ Options

Name	Option Code	Reference Page
Brake	B	See P.189
Cable exit direction (Outside)	CJO	See P.189
Motor side-mounted to the left	ML	See P.193
Motor side-mounted to the right	MR	See P.193
Non-motor end specification	NM	See P.194

Actuator Specifications

Item	Description
Drive system	Ball screw φ10mm, rolled C10
Positioning repeatability	±0.01mm
Lost motion	0.1mm or less
Base	Material: Aluminum with white alumite treatment
Static allowable moment	Ma: 169N·m, Mb: 242N·m, Mc: 137N·m
Dynamic allowable moment (*)	Ma: 49.5N·m, Mb: 70.7N·m, Mc: 40N·m
Ambient operating temp. & humidity	0~40°C, 85% RH or less (Non-condensing)

(*) Assumes a standard rated life of 5,000km. The service life will vary depending on operation and installation conditions.

Please refer to our website for more information regarding the directions of the allowable moment and overhang load length.

Please refer to RCP6 instruction manual regarding the displacement of the table.



*1 When the table is returning to its home position, please be careful of interference from surrounding objects, as it will travel until it reaches the M.E. Mechanical end SE: Stroke end
*2 For the single block type with 25/50mm (RCP6) and 25~125mm (RCP6S) strokes, tools cannot be used on the $\phi 6$ front mounting holes on the top surface because the motor unit interferes. Please use the mounting screw holes on the bottom surface.

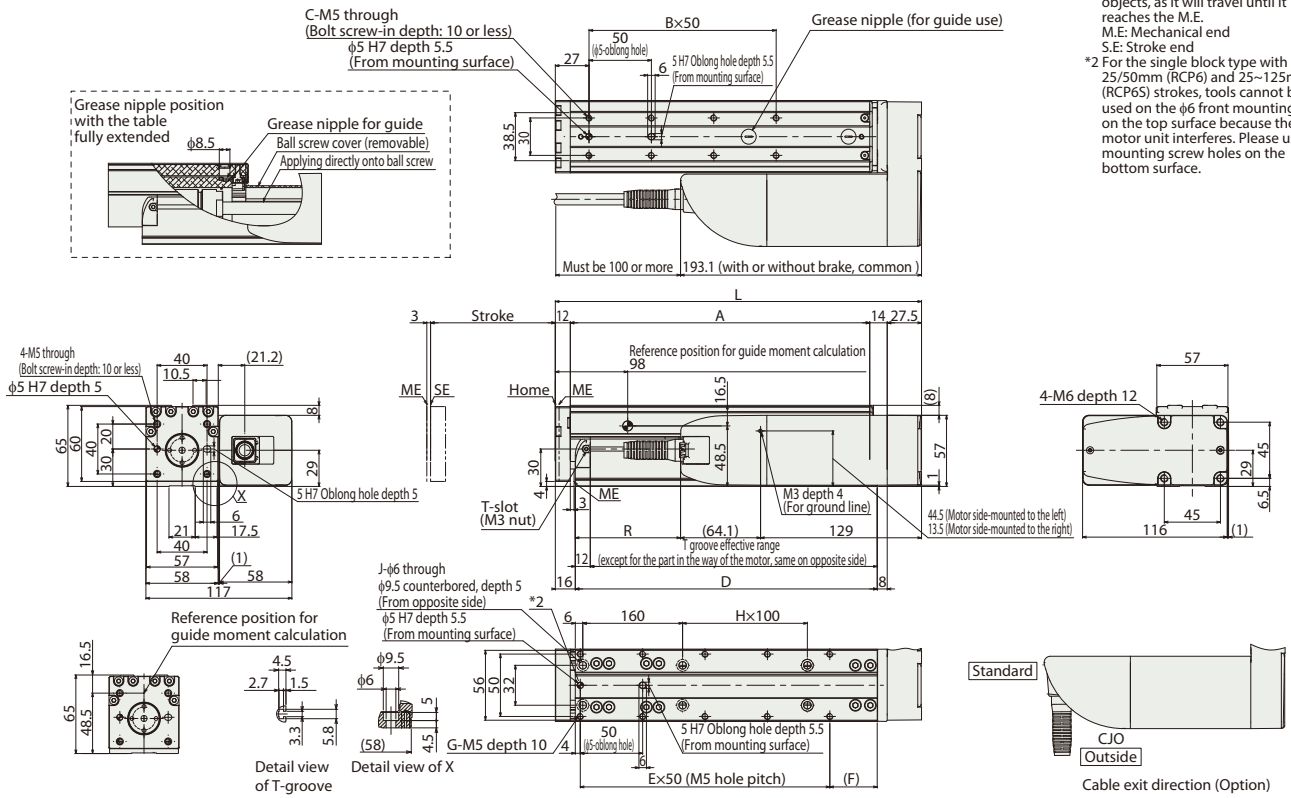

■ RCP6S-TA6R

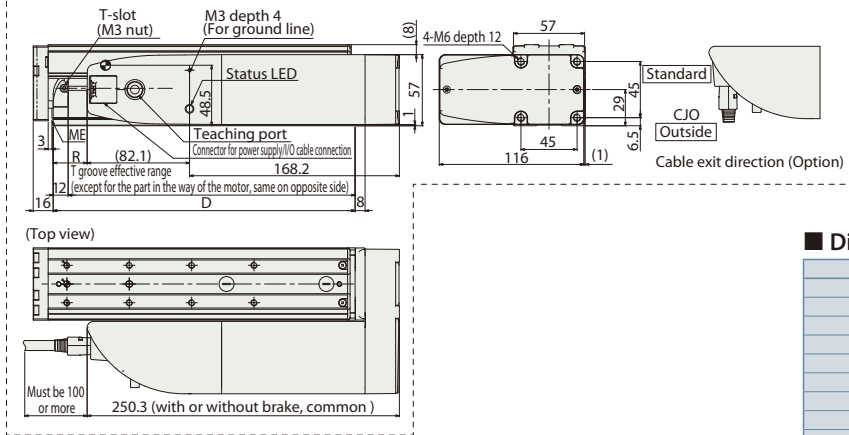

■ Dimensions and Mass by Stroke

Stroke	45	70	95	120	170	220	270	320
L	268.5	293.5	318.5	343.5	393.5	443.5	493.5	543.5
A	215	240	265	290	340	390	440	490
B	3	3	4	4	5	6	7	8
C	8	8	10	10	12	14	16	18
D	217	242	267	292	342	392	442	492
E	4	4	5	5	6	7	8	9
F	13	38	13	38	38	38	38	38
G	10	10	12	12	14	16	18	20
H	0	0	0	0	1	1	2	2
J	4	4	4	4	6	6	8	8
R	RCP6	59.4	84.4	109.4	134.4	184.4	234.4	284.4
	RCP6S	2.2	27.2	52.2	77.2	127.2	177.2	227.2
Mass (kg)	RCP6 w/o brake	3.2	3.4	3.5	3.7	4.0	4.3	4.7
	RCP6 w/ brake	3.3	3.4	3.6	3.8	4.1	4.4	5.0
	RCP6S w/o brake	3.3	3.5	3.7	3.8	4.1	4.5	4.8
	RCP6S w/ brake	3.4	3.6	3.7	3.9	4.2	4.5	4.9

② Applicable Controllers

The RCP6 series actuators can be operated by the controllers indicated below. Please select the type depending on your intended use. * Please refer to P.271 for more information about the built-in controller of RCP6S series.

Name	External view	Max. number of controlled axes	Input power	Control method				Maximum number of positioning points	Reference page
				Positioner	Pulse train	Program	Network * Option		
PCON-CYB/PLB/POB		1	DC24V	●	●	—	Network cannot be selected	64	Please contact IAI for more information.
PCON-CB/CGB		1		* Option	* Option	—	DeviceNet MECHATROLINK CC-Link EtherCAT EtherNet/IP CANopen CompoNet	512 (768 for network spec.)	Please see P.255
MCON-C/CG		8		This model is network-compatible only.				256	Please contact IAI for more information.
MCON-LC/LCG		6		—	—	●	Note: The type of compatible networks will vary depending on the controller. Please refer to reference page for more information.	256	Please contact IAI for more information.
MSEL-PC/PG		4	Single-phase 100 ~ 230 VAC	—	—	●		30,000	Please contact IAI for more information.
RCM-P6PC		1		Usable within the RCP6S Gateway system.				768	Please see P.279

* For the MCON controller, high-output enabled operation is only available if "high-output setting" is selected as an option. The maximum connectable axes with high-output enabled are C: 4 and LC: 3.

Foreword
Slider Type
Wide Slider Type
Rod Type
Radial Cylinder
Wide Radial Cylinder
Table Type
Cleanroom Slider
Cleanroom Wide Slider
Dust/Splash-Proof Rod
Dust/Splash-Proof Radial Cylinder
Dust/Splash-Proof Wide Radial Cylinder
Options
Reference Data
Controller

RCP6(S)-TA7R <Single Block Specifications>

Battery-less Absolute

Motor Unit Type

Side-mounted Motor

Body Width 70* mm

24v Stepper Motor

Model Specification Items

Series	Type	Encoder Type	Motor Type	Lead	Stroke	Applicable Controller / I/O Type	Cable Length	Options
RCP6: Separate Controller RCP6S: Built-in Controller	TA7R	WA: Battery-less Absolute	56P: Stepper Motor 56□ Size	24: 24mm 16: 16mm 8: 8mm 4: 4mm	25: 25mm 300: 300mm	[RCP6] P3: PCON MCON MSEL P5: RCM-P6PC [RCP6S] SE: SIO Type	N: None P: 1m S: 3m M: 5m X□□: Specified Length R□□: Robot Cable	Please refer to the options table below. *Please make sure to specify either ML or MR when ordering the side-mounted motor type.

* RCP6 does not include a controller. RCP6S includes a built-in controller.
* Please refer to P.17 for more information about the model specification items.

* Body width does not include the width of the side-mounted motor.

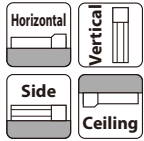

*Some limitations may apply to horizontal/side/ceiling mountings depending on the model. See page 204. Please contact IAI for more information.

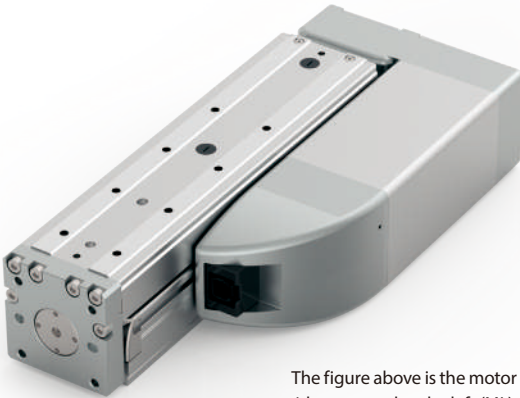

The figure above is the motor side-mounted to the left (ML).



- (1) The maximum acceleration/deceleration is 1G for horizontal, and 0.5G for vertical use.
- (2) The actuator specification displays the payload's maximum value, but it will vary depending on the acceleration and speed. Please refer to the "Selection Guidelines" (Tables of Payload by Speed/Acceleration) on P.229 for more details.
- (3) Please refer to P205 for performing push-motion operation.
- (4) Depending on the ambient operational temperature, duty control is necessary for the RCP6S (built-in controller type) with lead 4/8/16. Please refer to P.247 for more information.

Correlation Diagrams of Speed and Payload

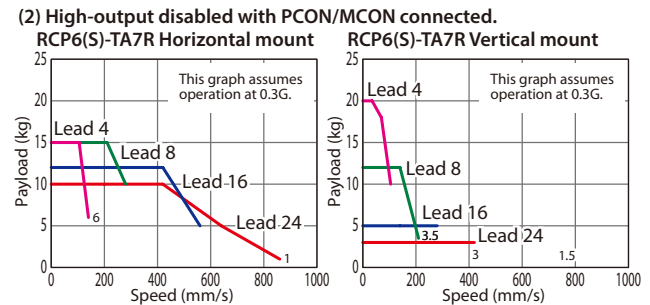
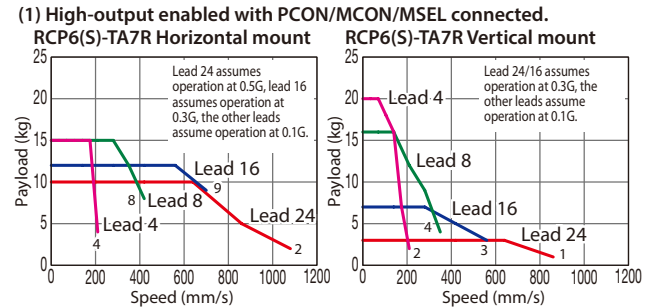

Actuator Specifications

Lead and Payload

* Push force only available during push mode w / limited speed.

Stroke and Max. Speed

(Unit: mm/s)

Model Number	Lead (mm)	Connected Controller	Max. Payload		Stroke (mm)
			Horizontal (kg)	Vertical (kg)	
RCP6(S)-TA7R-WA-56P-24-①-②-③-④	24	High-output Enabled High-output Disabled	10	3	25~300
RCP6(S)-TA7R-WA-56P-16-①-②-③-④	16	High-output Enabled	12	7	
		High-output Disabled	5	168	
RCP6(S)-TA7R-WA-56P-8-①-②-③-④	8	High-output Enabled	15	16	
		High-output Disabled	12	336	
RCP6(S)-TA7R-WA-56P-4-①-②-③-④	4	High-output Enabled	15	20	
		High-output Disabled		673	

Lead (mm)	Connected Controller	25~300 (mm)
		24
16	High-output Enabled	700 <560>
	High-output Disabled	560 <280>
8	High-output Enabled	420 <350>
	High-output Disabled	280 <210>
4	High-output Enabled	210
	High-output Disabled	140 <105>

Legend: ① Stroke ② Applicable controller/I/O type ③ Cable length ④ Options

Values in brackets < > are for vertical use.

① Stroke

Stroke (mm)	RCP6	RCP6S
25	○	○
50	○	○
75	○	○
100	○	○
125	○	○
150	○	○
175	○	○
200	○	○
250	○	○
300	○	○

③ Cable Length

Cable Type	Cable Code	RCP6		RCP6S
		P3	P5	SE
Standard	P (1m)	○	○	○
	S (3m)	○	○	○
	M (5m)	○	○	○
		○	○	○
Specified Length	X06 (6m) ~X10 (10m)	○	○	○
	X11 (11m) ~X15 (15m)	○	○	○
	X16 (16m) ~X20 (20m)	○	○	○
		○	○	○
Robot Cable	R01 (1m) ~R03 (3m)	○	○	○
	R04 (4m) ~R05 (5m)	○	○	○
	R06 (6m) ~R10 (10m)	○	○	○
	R11 (11m) ~R15 (15m)	○	○	○
	R16 (16m) ~R20 (20m)	○	○	○
		○	○	○

* Please refer to P. 267 and 283 for more information regarding the maintenance cables.

④ Options

Name	Option Code	Reference Page
Brake	B	See P.189
Cable exit direction (Outside)	CJO	See P.189
Motor side-mounted to the left	ML	See P.193
Motor side-mounted to the right	MR	See P.193
Non-motor end specification	NM	See P.194

When selecting multiple options, please list them in alphabetical order. (e.g. B-CJB-NM)

Actuator Specifications

Item	Description
Drive system	Ball screw φ12mm, rolled C10
Positioning repeatability	±0.01mm
Lost motion	0.1mm or less
Base	Material: Aluminum with white alumite treatment
Static allowable moment	Ma: 115N·m, Mb: 115N·m, Mc: 229N·m
Dynamic allowable moment (*)	Ma: 44.7N·m, Mb: 44.7N·m, Mc: 89.1N·m
Ambient operating temp. & humidity	0~40°C, 85% RH or less (Non-condensing)

(*) Assumes a standard rated life of 5,000km. The service life will vary depending on operation and installation conditions.

Please refer to our website for more information regarding the directions of the allowable moment and overhang load length.

Please refer to RCP6 instruction manual regarding the displacement of the table.

CAD drawings can be downloaded from our website.
www.intelligentactuator.com



*1 When the table is returning to its home position, please be careful of interference from surrounding objects, as it will travel until it reaches the M.E.
M.E: Mechanical end S.E: Stroke end

*2 For the single block type with 25~75mm (RCP6) and 25~125mm (RCP6S) strokes, tools cannot be used on the φ7 front mounting holes on the top surface because the motor unit interferes.
Please use the mounting screw holes on the bottom surface.

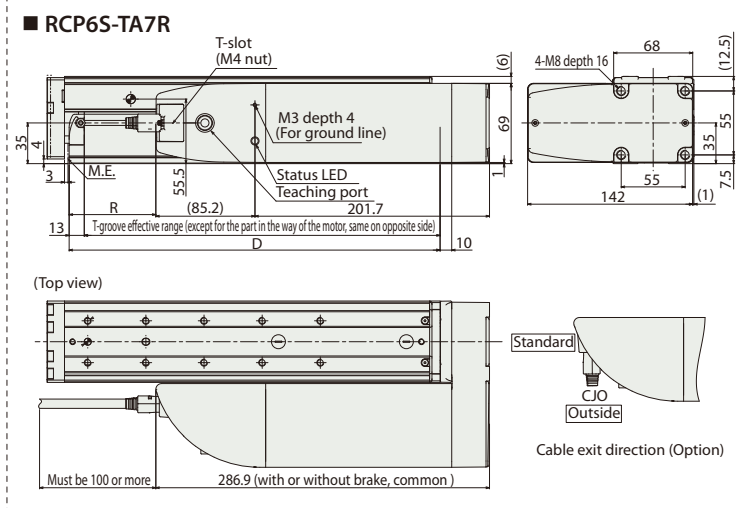
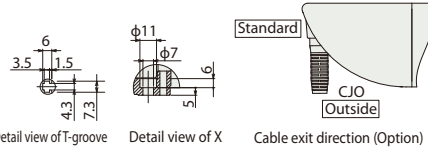
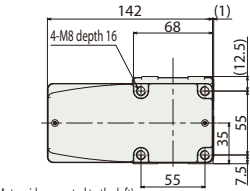
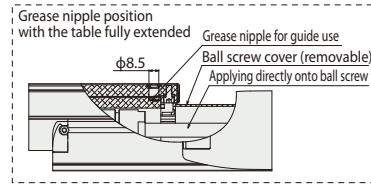
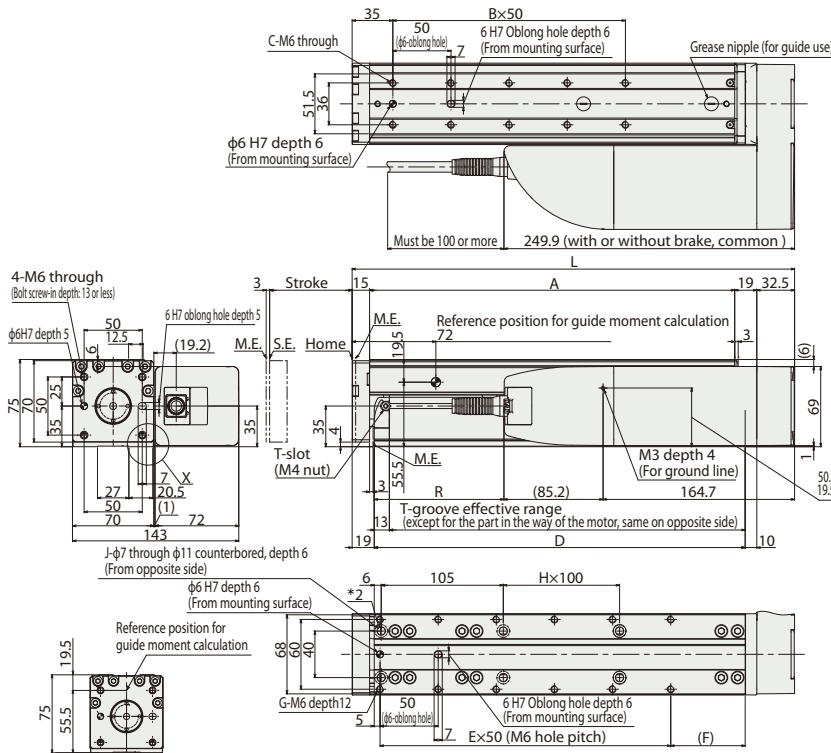

■ Dimensions and Mass by Stroke

Stroke	25	50	75	100	125	150	175	200	250	300	
L	205.5	230.5	255.5	280.5	305.5	330.5	355.5	380.5	430.5	480.5	
A	139	164	189	214	239	264	289	314	364	414	
B	1	1	2	2	3	3	4	4	5	6	
C	4	4	6	6	8	8	10	10	12	14	
D	144	169	194	219	244	269	294	319	369	419	
E	2	2	3	3	4	4	5	5	6	7	
F	39	64	39	64	39	64	39	64	64	64	
G	6	6	8	8	10	10	12	12	14	16	
H	0	0	0	0	1	1	1	1	2	2	
J	4	4	4	4	6	6	6	6	8	8	
R *	RCP6	-63.4	-38.4	-13.4	11.6	36.6	61.6	86.6	111.6	161.6	211.6
	RCP6S	-100.4	-75.4	-50.4	-25.4	-0.4	24.6	49.6	74.6	124.6	174.6
Mass (kg)	RCP6	w/o brake	4.4	4.6	4.9	5.1	5.3	5.5	5.7	5.9	6.4
		w/ brake	4.5	4.8	5.0	5.2	5.4	5.6	5.8	6.0	6.5
	RCP6S	w/o brake	4.5	4.8	5.0	5.2	5.4	5.6	5.8	6.1	6.5
		w/ brake	4.6	4.9	5.1	5.3	5.5	5.7	5.9	6.2	6.6

* If the length for R is negative in the table below, the length of the actuator body is shorter than the motor unit.

② Applicable Controllers

The RCP6 series actuators can be operated by the controllers indicated below. Please select the type depending on your intended use. * Please refer to P.271 for more information about the built-in controller of RCP6S series.

Name	External view	Max. number of controlled axes	Input power	Control method				Maximum number of positioning points	Reference page
				Positioner	Pulse train	Program	Network * Option		
PCON-CYB/PLB/POB		1	DC24V	●	●	-	Network cannot be selected	64	Please contact IAI for more information.
PCON-CB/CGB		1		* Option	* Option	-	DeviceNet MECHATROLINK EtherCAT EtherNet/IP	512 (768 for network spec.)	Please see P.255
MCON-C/CG		8		This model is network-compatible only.				256	Please contact IAI for more information.
MCON-LC/LCG		6		-	-	●	CompoNet SSCNET III/H	256	Please contact IAI for more information.
MSEL-PC/PG		4	Single-phase 100 ~ 230 VAC	-	-	●	Note: The type of compatible networks will vary depending on the controller. Please refer to reference page for more information.	30,000	Please contact IAI for more information.
RCM-P6PC		1		Usable within the RCP6S Gateway system.				768	Please see P.279

* For the MCON controller, high-output enabled operation is only available if "high-output setting" is selected as an option. The maximum connectable axes with high-output enabled are C: 4 and LC: 3.

Foreword
 Slider Type
 Wide Slider Type
 Rod Type
 Radial Cylinder
 Wide Radial Cylinder
 Table Type
 Cleanroom Slider
 Cleanroom Wide Slider
 Dust/Splash-Proof Rod
 Dust/Splash-Proof Radial Cylinder *
 Dust/Splash-Proof Wide Radial Cylinder
 Options
 Reference Data
 Controller

RCP6(S)-TA7R <Double Block Specification>

Battery-less Absolute Motor Unit Type Side-mounted Motor Body Width 70mm* 24v Stepper Motor

Model Specification Items	Series	TA7R	Encoder Type	WA	Motor Type	56P	Lead	Stroke	Applicable Controller/I/O Type	Cable Length	Options
	RCP6: Separate Controller RCP6S: Built-in Controller		WA: Battery-less Absolute	56P: Stepper Motor 56□ Size	16: 16mm 8: 8mm 4: 4mm	40: 40mm 390: 390mm	[RCP6] P3: PCON MCON MSEL P5: RCM-P6PC [RCP6S] SE: SIO Type	N: None P: 1m S: 3m M: 5m XC□□: Specified Length R□□: Robot Cable	Please refer to the options table below. *Model number symbols should be written in alphabetical order, including "DB".		

* RCP6 does not include a controller. RCP6S includes a built-in controller.
* Please refer to P.17 for more information about the model specification items.

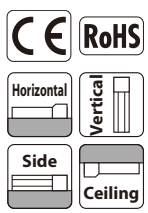

*Some limitations may apply to horizontal/side/ceiling mountings depending on the model. See page 204. Please contact IAI for more information.

The figure above is the motor side-mounted to left (ML).

- POINT Selection Notes**
- (1) The maximum acceleration/deceleration is 1G for horizontal, and 0.5G for vertical use.
 - (2) The actuator specifications displays the payload's maximum value, but it will vary depending on the acceleration and speed. Please refer to the "Selection Guidelines" (Tables of Payload by Speed/Acceleration) on P.230 for more details.
 - (3) Please refer to P205 for performing push-motion operation.
 - (4) Depending on the ambient operating temperature, duty control is necessary for the RCP6S (built-in controller type) with lead 4/8/16. Please refer to P.247 for more information.

Correlation Diagrams of Speed and Payload

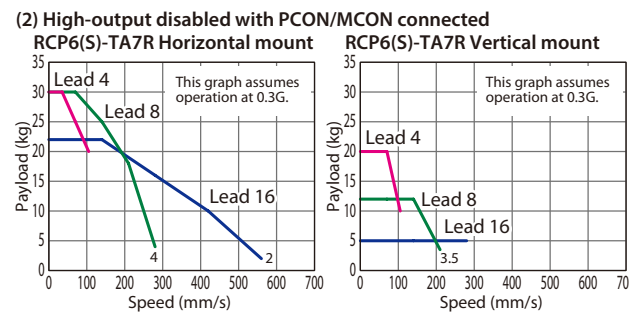
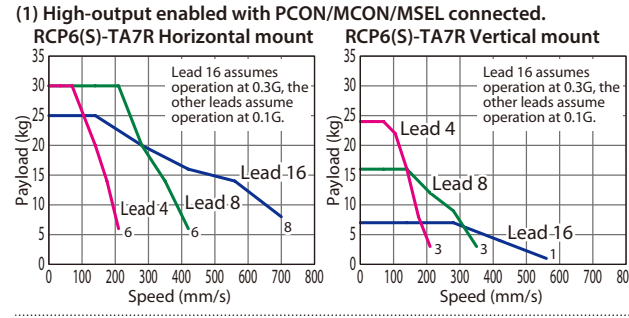

Actuator Specifications

Model Number	Lead (mm)	Connected Controller	Max. Payload		Max. Push Force (N)*	Stroke (mm)	Stroke and Max Speed (Unit: mm/s)				
			Horizontal (kg)	Vertical (kg)			Lead (mm)	Connected Controller	40~290 (mm)	340 (mm)	390 (mm)
RCP6(S)-TA7R-WA-56P-16-①-②-③-DB-④	16	High-output Enabled	25	7	168	40~390	16	High-output Enabled	700<560>		600<560>
		High-output Disabled	22	5				560<280>			
RCP6(S)-TA7R-WA-56P-8-①-②-③-DB-④	8	High-output Enabled	30	16	336	40~390	8	High-output Enabled	420<350>	365<350>	300
		High-output Disabled		12				280<210>			
RCP6(S)-TA7R-WA-56P-4-①-②-③-DB-④	4	High-output Enabled	30	24	673	40~390	4	High-output Enabled	210	180	150
		High-output Disabled		20				105			

Legend: ① Stroke ② Applicable controllers/I/O type ③ Cable length ④ Options Values in brackets <> are for vertical use.

① Stroke

Stroke (mm)	RCP6	RCP6S
40	○	○
65	○	○
90	○	○
140	○	○
190	○	○
240	○	○
290	○	○
340	○	○
390	○	○

③ Cable Length

Cable Type	Cable Code	RCP6			RCP6S
		P3	P5	SE	
Standard	P(1m)	○	○	○	
	S(3m)	○	○	○	
	M(5m)	○	○	○	
Specified length	X06 (6m) ~X10 (10m)	○	○	○	
	X11 (11m) ~X15 (15m)	○	○	○	
	X16 (16m) ~X20 (20m)	○	○	○	
Robot cable	R01 (1m) ~R03 (3m)	○	○	○	
	R04 (4m) ~R05 (5m)	○	○	○	
	R06 (6m) ~R10 (10m)	○	○	○	
	R11 (11m) ~R15 (15m)	○	○	○	
	R16 (16m) ~R20 (20m)	○	○	○	

* Please refer to P. 267 and 283 for more information regarding the maintenance cables.

④ Options

Name	Option Code	Reference Page
Brake	B	See P.189
Cable exit direction (Outside)	CJO	See P.189
Motor side-mounted to the left	ML	See P.193
Motor side-mounted to the right	MR	See P.193
Non-motor end specification	NM	See P.194

Actuator Specifications

Item	Description
Drive system	Ball screw φ12mm, rolled C10
Positioning repeatability	±0.01mm
Lost motion	0.1mm or less
Base	Material: Aluminum with white alumite treatment
Static allowable moment	Ma: 620N-m, Mb: 620N-m, Mc: 458N-m
Dynamic allowable moment (*)	Ma: 196N-m, Mb: 196N-m, Mc: 145N-m
Ambient operating temp. & humidity	0~40°C, 85% RH or less (Non-condensing)

(*) Assumes a standard rated life of 5,000km. The service life will vary depending on operation and installation conditions.

Please refer to our website for more information regarding the directions of the allowable moment and overhang load length. Please refer to RCP6 instruction manual regarding the displacement of the table.

RCP6(S)CR-SA4C



Model Specification Items

— **SA4C** — **WA** — **35P** — — — — —

Series — Type — Encoder Type — Motor Type — Lead — Stroke — Applicable Controller/I/O Type — Cable Length — Options

RCP6CR: Separate Controller
 RCP6SCR: Built-in Controller

WA: Battery-less Absolute
 35P: Stepper Motor 35□ Size

16: 16mm
 10: 10mm
 5: 5mm
 2.5: 2.5mm

50: 50mm
 500: 500mm (Every 50mm)

[RCP6]
 P3: PCON
 MCO
 MSEL
 P5: RCM-P6PC
 [RCP6S]
 SE: SIO Type

N: None
 P: 1m
 S: 3m
 M: 5m
 X□□: Specified Length
 R□□: Robot Cable

Please refer to the options table below.

* RCP6 does not include a controller. RCP6S includes a built-in controller.
 * Please refer to P.18 for more information about the model specification items.

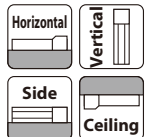

*Some limitations may apply to horizontal/side/ceiling mountings depending on the model. See page 204. Please contact IAI for more information.

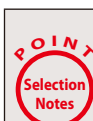
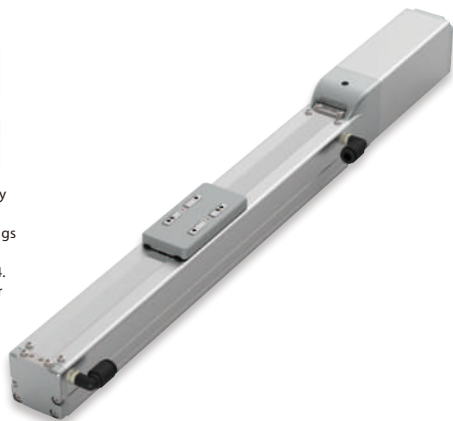

- The maximum acceleration/deceleration is 1G for horizontal, and 0.5G for vertical use.
- The actuator specifications displays the payload's maximum value, but it will vary depending on the acceleration and speed. Please refer to the "Selection Guidelines" (Tables of Payload by Speed/Acceleration) on P.207 for more details.
- When performing push-motion operation, please confirm the push force of each model by checking the "Correlation diagrams of push force and current limit" on P.205.

Correlation Diagrams of Speed and Payload

(1) High-output enabled with PCON/MCON/MSEL connected.

RCP6(S)CR-SA4C Horizontal mount

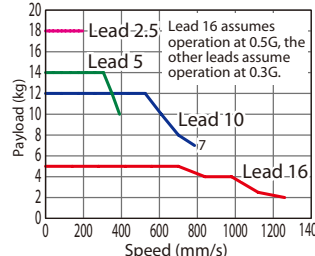

RCP6(S)CR-SA4C Vertical mount

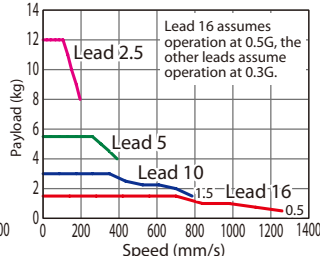

(2) High-output disabled with PCON/MCON connected

RCP6(S)CR-SA4C Horizontal mount

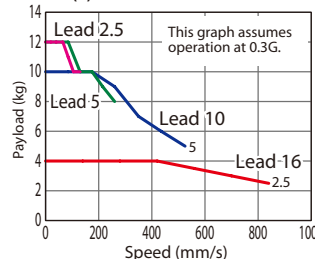

RCP6(S)CR-SA4C Vertical mount

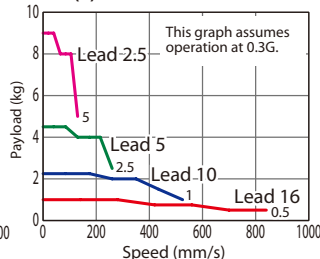

Actuator Specifications

Lead and Payload

* Push force only available during push mode w / limited speed.

Model Number	Lead (mm)	Connected Controller	Max. Payload		Max. Push Force (N)*
			Horizontal (kg)	Vertical (kg)	
RCP6(S)CR-SA4C-WA-35P-16-①-②-③-④	16	High-output Enabled	7	1.5	48
		High-output Disabled	4	1	
RCP6(S)CR-SA4C-WA-35P-10-①-②-③-④	10	High-output Enabled	12	3	77
		High-output Disabled	10	2.25	
RCP6(S)CR-SA4C-WA-35P-5-①-②-③-④	5	High-output Enabled	14	5.5	155
		High-output Disabled	12	4.5	
RCP6(S)CR-SA4C-WA-35P-2.5-①-②-③-④	2.5	High-output Enabled	18	12	310
		High-output Disabled	12	9	

Legend: ① Stroke ② Applicable controllers/I/O type ③ Cable length ④ Options

Stroke and Max Speed/Suction Amount

(Unit: mm/s)

Lead (mm)	Connected Controller	50~400 (Every 50mm)	450 (mm)	500 (mm)	Suction amount (N/min)
		Max. Speed	Max. Speed	Max. Speed	
16	High-output Enabled	1,260	1,060	875	60
	High-output Disabled		840		
10	High-output Enabled	785	675	555	40
	High-output Disabled		525		
5	High-output Enabled	390	330	275	20
	High-output Disabled		260		
2.5	High-output Enabled	195	165	135	10
	High-output Disabled		130		

① Stroke

Stroke (mm)	RCP6CR	RCP6SCR	Stroke (mm)	RCP6CR	RCP6SCR
50	○	○	300	○	○
100	○	○	350	○	○
150	○	○	400	○	○
200	○	○	450	○	○
250	○	○	500	○	○

③ Cable Length

Cable Type	Cable Code	RCP6CR			RCP6SCR
		P3	P5	SE	
Standard	P(1m)	○	○	○	○
	S(3m)	○	○	○	○
	M(5m)	○	○	○	○
	X06 (6m) ~X10 (10m)	○	○	○	○
Specified length	X11 (11m) ~X15 (15m)	○	○	○	○
	X16 (16m) ~X20 (20m)	○	○	○	○
	R01 (1m) ~R03 (3m)	○	○	○	○
	R04 (4m) ~R05 (5m)	○	○	○	○
Robot cable	R06 (6m) ~R10 (10m)	○	○	○	○
	R11 (11m) ~R15 (15m)	○	○	○	○
	R16 (16m) ~R20 (20m)	○	○	○	○
		○	○	○	○

* Please refer to P. 267 and 283 for more information regarding the maintenance cables.

④ Options

Name	Option Code	Reference Page
Brake	B	See P.189
Cable exit direction (Top)	CJT	See P.189
Cable exit direction (Right)	CJR	See P.189
Cable exit direction (Left)	CJL	See P.189
Cable exit direction (Bottom)	CJB	See P.189
Designated grease coating specification	G3/G4	
High-precision specification (*1)	HPR	See P.192
Non-motor end specification	NM	See P.194
Air suction joint in opposite position	VR	See P.195
Double slider specification (*2)	W	See P.196

(*1) When the lead is 16, it cannot be selected. Double slider specification cannot be selected.
 (*2) Some leads cannot be selected. (See P. 248)

Actuator Specifications

Item	Description
Drive system	Ball screw φ8mm, rolled C10
Positioning repeatability (*1)	±0.01mm [±0.005mm]
Lost motion	0.1mm or less
Base	Material: Aluminum with white alumite treatment
Static allowable moment	Ma: 13.0N·m, Mb: 18.6N·m, Mc: 25.3N·m
Dynamic allowable moment (*2)	Ma: 5.0N·m, Mb: 7.1N·m, Mc: 9.7N·m
Cleanliness	Class 10 (Fed.Std.209D), class 2.5 or equivalent (ISO 14644-1 Standard)
Ambient operating temp. & humidity	0~40°C, 85% RH or less (Non-condensing)

* Reference for overhang load length: Ma: 150mm or less, Mb, Mc: 150mm or less
 (*1) Values in [] are for high precision (for lead 2.5/5/10) specification.
 (*2) Assumes a standard rated life of 5,000km. The service life will vary depending on operation and installation conditions.

Please refer to our website for more information regarding the directions of the allowable moment and overhang load length.

RCP6(S)CR-SA6C



Model Specification Items

— **SA6C** — **WA** — **42P** — — — — —

Series — Type — Encoder Type — Motor Type — Lead — Stroke — Applicable Controller/I/O Type — Cable Length — Options

RCP6CR: Separate Controller
RCP6SCR: Built-in Controller

WA: Battery-less Absolute
42P: Stepper Motor 42□ Size

20 : 20mm
12 : 12mm
6 : 6mm
3 : 3mm

50 : 50mm
800 : 800mm (Every 50mm)

[RCP6]
P3 : PCON
MCON
MSEL
P5 : RCM-P6PC
[RCP6S]
SE: SIO Type

N : None
P : 1m
S : 3m
M : 5m
XC□ : Specified Length
R□ : Robot Cable

Please refer to the options table below.

* RCP6 does not include a controller. RCP6S includes a built-in controller.
* Please refer to P.18 for more information about the model specification items.

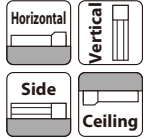

*Some limitations may apply to horizontal/side/ceiling mountings depending on the model. See page 204. Please contact IAI for more information.



POINT Selection Notes

- The maximum acceleration/deceleration is 1G for horizontal, and 0.5G for vertical use.
- The actuator specifications displays the payload's maximum value, but it will vary depending on the acceleration and speed. Please refer to the "Selection Guidelines" (Tables of Payload by Speed/Acceleration) on P.207 for more details.
- When performing push-motion operation, please confirm the push force of each model by checking the "Correlation diagrams of push force and current limit" on P.205.
- Depending on the ambient operating temperature, duty control is necessary for the RCP6S (built-in controller type) with lead 3/6. Please refer to P.247 for more information.

Correlation Diagrams of Speed and Payload

(1) High-output enabled with PCON/MCON/MSEL connected.

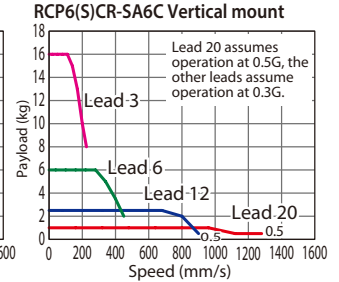
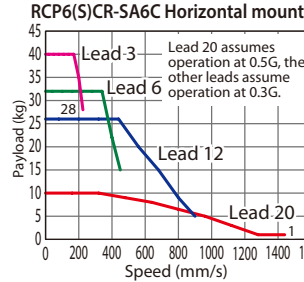

(2) High-output disabled with PCON/MCON connected.

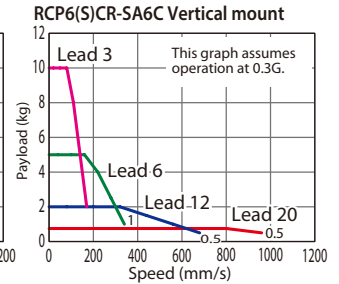
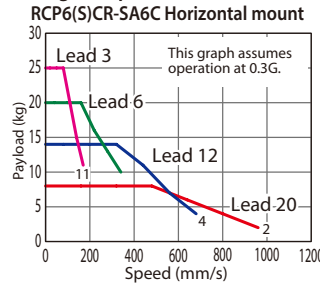

Actuator Specifications

Lead and Payload

* Push force only available during push mode w / limited speed. H: Horizontal V: Vertical

Model Number	Lead (mm)	Connected Controller	Max. Payload H(kg) V(kg)	Max. Push Force (N)*
RCP6(S)CR-SA6C-WA-42P-20-①②③④	20	High-output Enabled	15 1	56
		High-output Disabled	8 0.75	
RCP6(S)CR-SA6C-WA-42P-12-①②③④	12	High-output Enabled	28 2.5	93
		High-output Disabled	14 2	
RCP6(S)CR-SA6C-WA-42P-6-①②③④	6	High-output Enabled	32 6	185
		High-output Disabled	20 5	
RCP6(S)CR-SA6C-WA-42P-3-①②③④	3	High-output Enabled	40 16	370
		High-output Disabled	25 10	

Legend: ① Stroke ② Applicable controllers/I/O type ③ Cable length ④ Options

Stroke and Max Speed/Suction Amount

(Unit: mm/s)

Lead (mm)	Connected Controller	50-400 (Every 50mm) (mm)	450 (mm)	500 (mm)	550 (mm)	600 (mm)	650 (mm)	700 (mm)	750 (mm)	800 (mm)	Suction amount (N/min)
20	High-output Enabled	1,440 <1,280>	1,335 <1,280>	1,130	970	840	735	650	575	100	
	High-output Disabled	960		840	735	650	575				
12	High-output Enabled	900	885	735	620	535	460	405	355	70	
	High-output Disabled	680		620	535	460	405	355	315		
6	High-output Enabled	450	435	365	305	265	230	200	175	30	
	High-output Disabled	340		305	265	230	200	175	155		
3	High-output Enabled	225	215	180	150	130	115	100	85	15	
	High-output Disabled	170		150	130	115	100	85	75		

Values in brackets <> are for vertical use.

① Stroke

Stroke (mm)	RCP6CR	RCP6SCR	Stroke (mm)	RCP6CR	RCP6SCR
50	○	○	450	○	○
100	○	○	500	○	○
150	○	○	550	○	○
200	○	○	600	○	○
250	○	○	650	○	○
300	○	○	700	○	○
350	○	○	750	○	○
400	○	○	800	○	○

④ Options

Name	Option Code	Reference Page
Brake	B	See P.189
Cable exit direction (Top)	CJT	See P.189
Cable exit direction (Right)	CJR	See P.189
Cable exit direction (Left)	CJL	See P.189
Cable exit direction (Bottom)	CJB	See P.189
Designated grease coating specification	G3/G4	
High-precision specification (*1)	HPR	See P.192
Non-motor end specification	NM	See P.194
Air suction joint in opposite position	VR	See P.195
Double slider specification (*2)	W	See P.196

(*1) When the lead is 20, it cannot be selected. Double slider specification cannot be selected.
(*2) Some leads cannot be selected. (See P. 248)

③ Cable Length

Cable Type	Cable Code	RCP6CR			RCP6SCR
		P3	P5	SE	
Standard	P(1m)	○	○	○	
	S(3m)	○	○	○	
	M(5m)	○	○	○	
	X06 (6m) ~X10 (10m)	○	○	○	
Specified length	X11 (11m) ~X15 (15m)	○	○	○	
	X16 (16m) ~X20 (20m)	○	○	○	
	R01 (1m) ~R03 (3m)	○	○	○	
	R04 (4m) ~R05 (5m)	○	○	○	
Robot Cable	R06 (6m) ~R10 (10m)	○	○	○	
	R11 (11m) ~R15 (15m)	○	○	○	
	R16 (16m) ~R20 (20m)	○	○	○	

* Please refer to P. 267 and 283 for more information regarding the maintenance cables.

Actuator Specifications

Item	Description
Drive system	Ball screw φ10mm, rolled C10
Positioning repeatability (*1)	±0.01mm (±0.005mm)
Lost motion	0.1mm or less
Base	Material: Aluminum with white alumite treatment
Static allowable moment	Ma: 48.5N·m, Mb: 69.3N·m, Mc: 103N·m
Dynamic allowable moment (*2)	Ma: 11.6N·m, Mb: 16.6N·m, Mc: 24.6N·m
Cleanliness	Class 10 (Fed.Std.209D), class 2.5 or equivalent (ISO 14644-1 Standard)
Ambient operating temp. & humidity	0~40°C, 85% RH or less (Non-condensing)

* Reference for overhang load length: Ma: 220mm or less, Mb, Mc: 220mm or less
(*1) Values in [] are for high precision (for lead 3/6/12) specification.

(*2) Assumes a standard rated life of 5,000km. The service life will vary depending on operation and installation conditions.

Please refer to our website for more information regarding the directions of the allowable moment and overhang load length.

CAD drawings can be downloaded from our website.
www.intelligentactuator.com



*1 When the slider is returning to its home position, please be careful of interference from surrounding objects, as it will travel until it reaches the M.E.
M.E: Mechanical end S.E: Stroke end

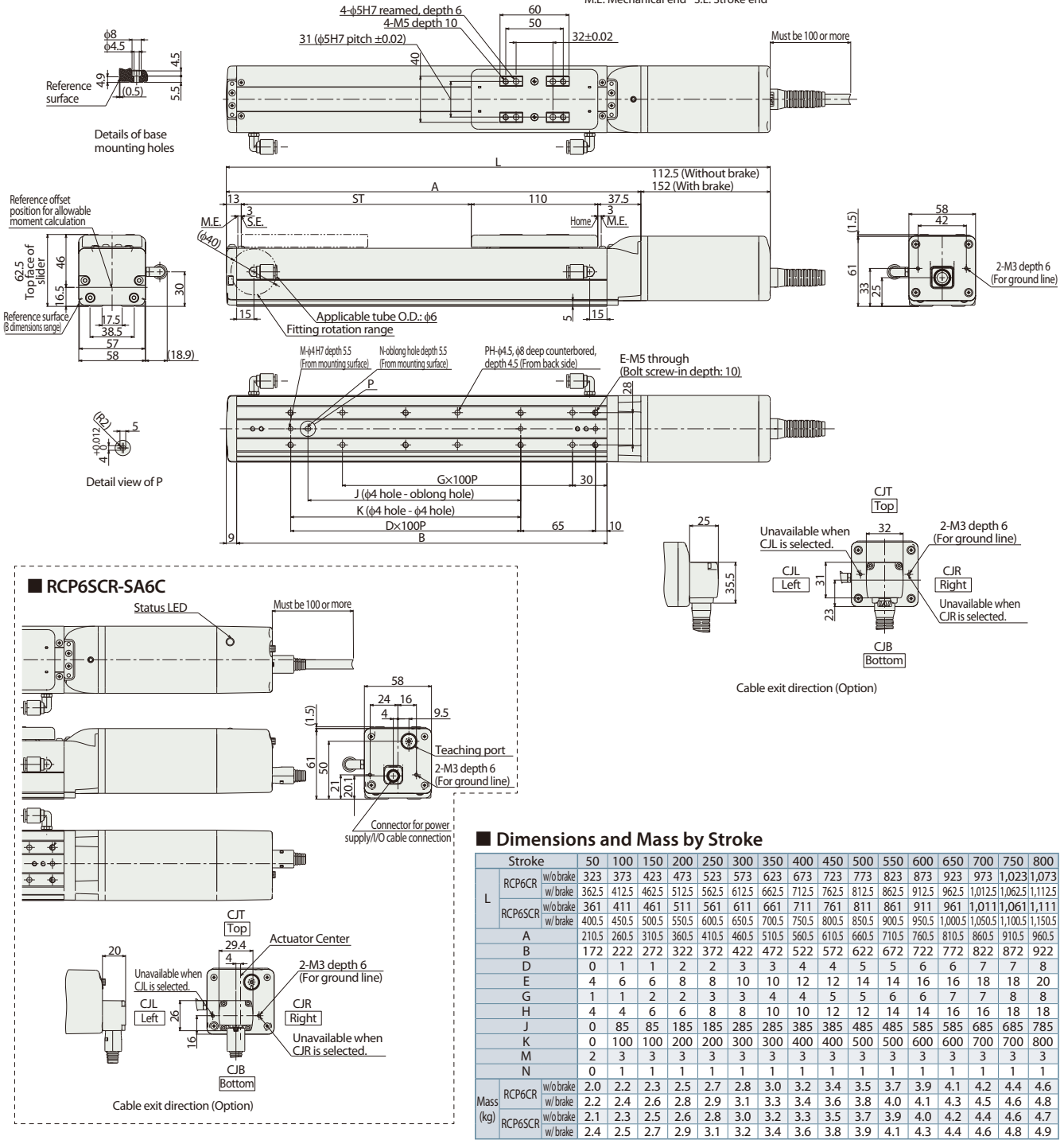

■ Dimensions and Mass by Stroke

Stroke	50	100	150	200	250	300	350	400	450	500	550	600	650	700	750	800	
L	RCP6CR w/o brake	323	373	423	473	523	573	623	673	723	773	823	873	923	973	1,023	1,073
	RCP6CR w/ brake	362.5	412.5	462.5	512.5	562.5	612.5	662.5	712.5	762.5	812.5	862.5	912.5	962.5	1,012.5	1,062.5	1,112.5
L	RCP6SCR w/o brake	361	411	461	511	561	611	661	711	761	811	861	911	961	1,011	1,061	1,111
	RCP6SCR w/ brake	400.5	450.5	500.5	550.5	600.5	650.5	700.5	750.5	800.5	850.5	900.5	950.5	1,000.5	1,050.5	1,100.5	1,150.5
A		210.5	260.5	310.5	360.5	410.5	460.5	510.5	560.5	610.5	660.5	710.5	760.5	810.5	860.5	910.5	960.5
B		172	222	272	322	372	422	472	522	572	622	672	722	772	822	872	922
D		0	1	1	2	2	3	3	4	4	5	5	6	6	7	7	8
E		4	6	6	8	8	10	10	12	12	14	14	16	16	18	18	20
G		1	1	2	2	3	3	4	4	5	5	6	6	7	7	8	8
H		4	4	6	6	8	8	10	10	12	12	14	14	16	16	18	18
J		0	85	85	185	185	285	285	385	385	485	485	585	585	685	685	785
K		0	100	100	200	200	300	300	400	400	500	500	600	600	700	700	800
M		2	3	3	3	3	3	3	3	3	3	3	3	3	3	3	3
N		0	1	1	1	1	1	1	1	1	1	1	1	1	1	1	1
Mass (kg)	RCP6CR w/o brake	2.0	2.2	2.3	2.5	2.7	2.8	3.0	3.2	3.4	3.5	3.7	3.9	4.1	4.2	4.4	4.6
	RCP6CR w/ brake	2.2	2.4	2.6	2.8	2.9	3.1	3.3	3.4	3.6	3.8	4.0	4.1	4.3	4.5	4.6	4.8
Mass (kg)	RCP6SCR w/o brake	2.1	2.3	2.5	2.6	2.8	3.0	3.2	3.3	3.5	3.7	3.9	4.0	4.2	4.4	4.6	4.7
	RCP6SCR w/ brake	2.4	2.5	2.7	2.9	3.1	3.2	3.4	3.6	3.8	3.9	4.1	4.3	4.4	4.6	4.8	4.9

② Applicable Controllers

The RCP6 series actuators can be operated by the controllers indicated below. Please select the type depending on your intended use. * Please refer to P.271 for more information about the built-in controller of RCP6S series.

Name	External view	Max. number of controlled axes	Input power	Control method				Maximum number of positioning points	Reference page
				Positioner	Pulse train	Program	Network * Option		
PCON-CYB/PLB/POB		1	DC24V	●	●	-	Network cannot be selected	64	Please contact IAI for more information.
PCON-CB/CGB		1		* Option	* Option	-	DeviceNet MECHATROLINK CC-Link EtherCAT EtherNet/IP CANopen CompoNet	512 (768 for network spec.)	See P.255
MCON-C/CG		8		This model is network-compatible only.				256	Please contact IAI for more information.
MCON-LC/LCG		6		-	-	●	Note: The type of compatible networks will vary depending on the controller. Please refer to reference page for more information.	256	Please contact IAI for more information.
MSEL-PC/PG		4	Single-phase 100 ~ 230 VAC	-	-	30,000		Please contact IAI for more information.	
RCM-P6PC		1		Usable within the RCP6S Gateway system.				768	See P.279

* For the MCON controller, high-output enabled operation is only available if "high-output setting" is selected as an option. The maximum connectable axes with high-output enabled are C: 4 and LC: 3.

Foreword
Slider Type
Wide Slider Type
Rod Type
Radial Cylinder
Wide Radial Cylinder
Table Type
Cleanroom Slider
Cleanroom Wide Slider
Dust/Splash-Proof Rod
Dust/Splash-Proof Radial Cylinder
Dust/Splash-Proof Wide Radial Cylinder
Options
Reference Data
Controller

RCP6(S)CR-SA7C

±10μm Standard
±5μm Optional
Cleanroom Spec
Battery-less Absolute
Motor Unit Type
Coupled Motor
Body Width 70 mm
24v Stepper Motor

Model Specification Items	Series	Type	Encoder Type	Motor Type	Lead	Stroke	Applicable Controller/I/O Type	Cable Length	Options
	SA7C	WA	56P						
	RCP6CR: Separate Controller RCP6SCR: Built-in Controller	WA: Battery-less Absolute	56P: Stepper Motor 56□ Size	24 : 24mm 16 : 16mm 8 : 8mm 4 : 4mm	50:50mm 800:800mm (Every 50mm)	[RCP6] P3 : PCON MCON MSEL P5 : RCM-P6PC [RCP6S] SE: SIO Type	N : None P : 1m S : 3m M : 5m XC□ : Specified Length R□ : Robot Cable	Please refer to the options table below.	

* RCP6 does not include a controller. RCP6S includes a built-in controller.
* Please refer to P.18 for more information about the model specification items.

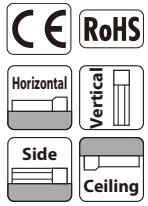

*Some limitations may apply to horizontal/side/ceiling mountings depending on the model. See page 204. Please contact IAI for more information.

POINT Selection Notes

- (1) The maximum acceleration/deceleration is 1G for horizontal, and 0.5G for vertical use.
- (2) The actuator specifications displays the payload's maximum value, but it will vary depending on the acceleration and speed. Please refer to the "Selection Guidelines" (Tables of Payload by Speed/Acceleration) on P.207 for more details.
- (3) When performing push-motion operation, please confirm the push force of each model by checking the "Correlation diagrams of push force and current limit" on P.205.
- (4) Depending on the ambient operating temperature, duty control is necessary for the RCP6S (built-in controller type) with lead 4/8/16. Please refer to P.247 for more information.

Correlation Diagrams of Speed and Payload

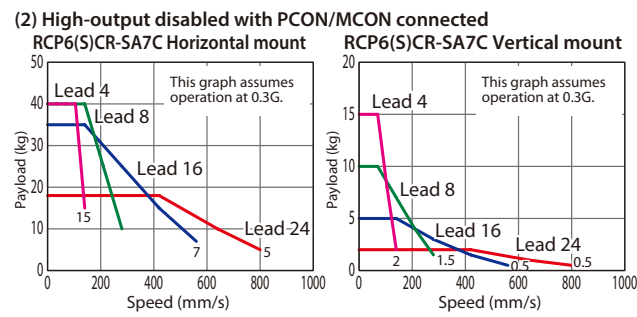
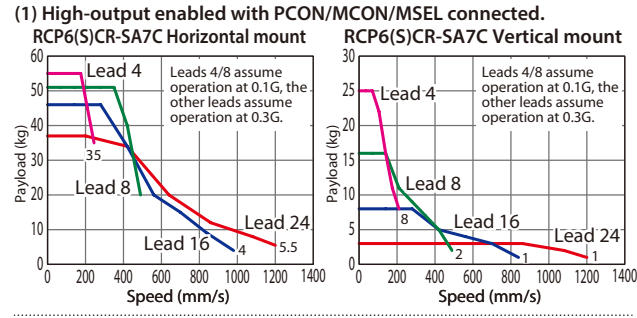

Actuator Specifications

Model Number	Lead (mm)	Connected Controller	Max. Payload		Max. Push Force (N)*	Lead (mm)	Connected Controller	Stroke and Max Speed/Suction Amount (Unit: mm/s)								Suction amount (Nl/min)
			Horizontal (kg)	Vertical (kg)				50-500 (Every 50mm)	550 (mm)	600 (mm)	650 (mm)	700 (mm)	750 (mm)	800 (mm)	800 (mm)	
RCP6(S)CR-SA7C-WA-56P-24-①②③④	24	High-output Enabled	37	3	112	24	High-output Enabled	1,200	1,095	965	850	760	90			
		High-output Disabled	18	2			800	760								
RCP6(S)CR-SA7C-WA-56P-16-①②③④	16	High-output Enabled	46	8	168	16	High-output Enabled	980<840>	965<840>	830	720	635	560	500		
		High-output Disabled	35	5			560	500								
RCP6(S)CR-SA7C-WA-56P-8-①②③④	8	High-output Enabled	51	16	336	8	High-output Enabled	490	475	410	355	315	275	245		
		High-output Disabled	40	10			280	275	245							
RCP6(S)CR-SA7C-WA-56P-4-①②③④	4	High-output Enabled	55	25	673	4	High-output Enabled	245<210>	235<210>	205	175	155	135	120		
		High-output Disabled	40	15			140	135	120							

Legend: ① Stroke ② Applicable controllers/I/O type ③ Cable length ④ Options Values in brackets <> are for vertical use.

① Stroke

Stroke (mm)	RCP6CR	RCP6SCR	Stroke (mm)	RCP6CR	RCP6SCR
50	○	○	450	○	○
100	○	○	500	○	○
150	○	○	550	○	○
200	○	○	600	○	○
250	○	○	650	○	○
300	○	○	700	○	○
350	○	○	750	○	○
400	○	○	800	○	○

④ Options

Name	Option Code	Reference Page
Brake	B	See P.189
Cable exit direction (Top)	CJT	See P.189
Cable exit direction (Right)	CJR	See P.189
Cable exit direction (Left)	CJL	See P.189
Cable exit direction (Bottom)	CJB	See P.189
Designated grease coating specification	G3/G4	
High-precision specification (*1)	HPR	See P.192
Non-motor end specification	NM	See P.194
Air suction joint in opposite position	VR	See P.195
Double slider specification (*2)	W	See P.196

(*1) When the lead is 16/24, it cannot be selected. Double slider specification cannot be selected.
(*2) Some leads cannot be selected. (See P. 248)

③ Cable Length

Cable Type	Cable Code	RCP6CR			RCP6SCR
		P3	P5	SE	
Standard	P(1m)	○	○	○	
	S(3m)	○	○	○	
	M(5m)	○	○	○	
Specified length	X06 (6m) ~X10 (10m)	○	○	○	
	X11 (11m) ~X15 (15m)	○	○	○	
	X16 (16m) ~X20 (20m)	○	○	○	
	R01 (1m) ~R03 (3m)	○	○	○	
Robot cable	R04 (4m) ~R05 (5m)	○	○	○	
	R06 (6m) ~R10 (10m)	○	○	○	
	R11 (11m) ~R15 (15m)	○	○	○	
	R16 (16m) ~R20 (20m)	○	○	○	

* Please refer to P. 267 and 283 for more information regarding the maintenance cables.

Actuator Specifications

Item	Description
Drive system	Ball screw φ12mm, rolled C10
Positioning repeatability (*1)	±0.01mm [±0.005mm]
Lost motion	0.1mm or less
Base	Material: Aluminum with white alumite treatment
Static allowable moment	Ma: 115N·m, Mb: 115N·m, Mc: 229N·m
Dynamic allowable moment (*2)	Ma: 44.7N·m, Mb: 44.7N·m, Mc: 89.1N·m
Cleanliness	Class 10 (Fed.Std.209D), class 2.5 or equivalent (ISO 14644-1 Standard)
Ambient operating temp. & humidity	0~40°C, 85% RH or less (Non-condensing)

* Reference for overhang load length: Ma: 300mm or less, Mb, Mc: 300mm or less
(*1) Values in [] are for high precision (for lead 4/8) specification.
(*2) Assumes a standard rated life of 5,000km. The service life will vary depending on operation and installation conditions.
Please refer to our website for more information regarding the directions of the allowable moment and overhang load length.



*1 When the slider is returning to its home position, please be careful of interference from surrounding objects, as it will travel until it reaches the M.E.
M.E: Mechanical end S.E: Stroke end

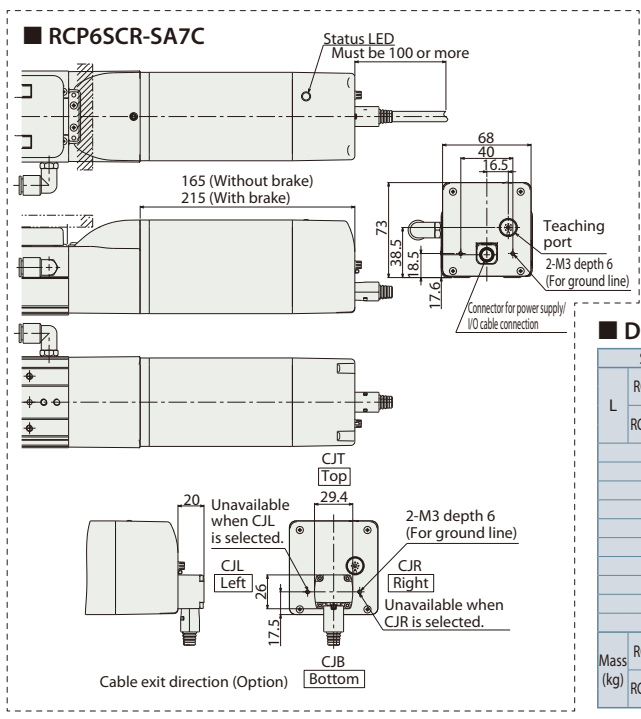
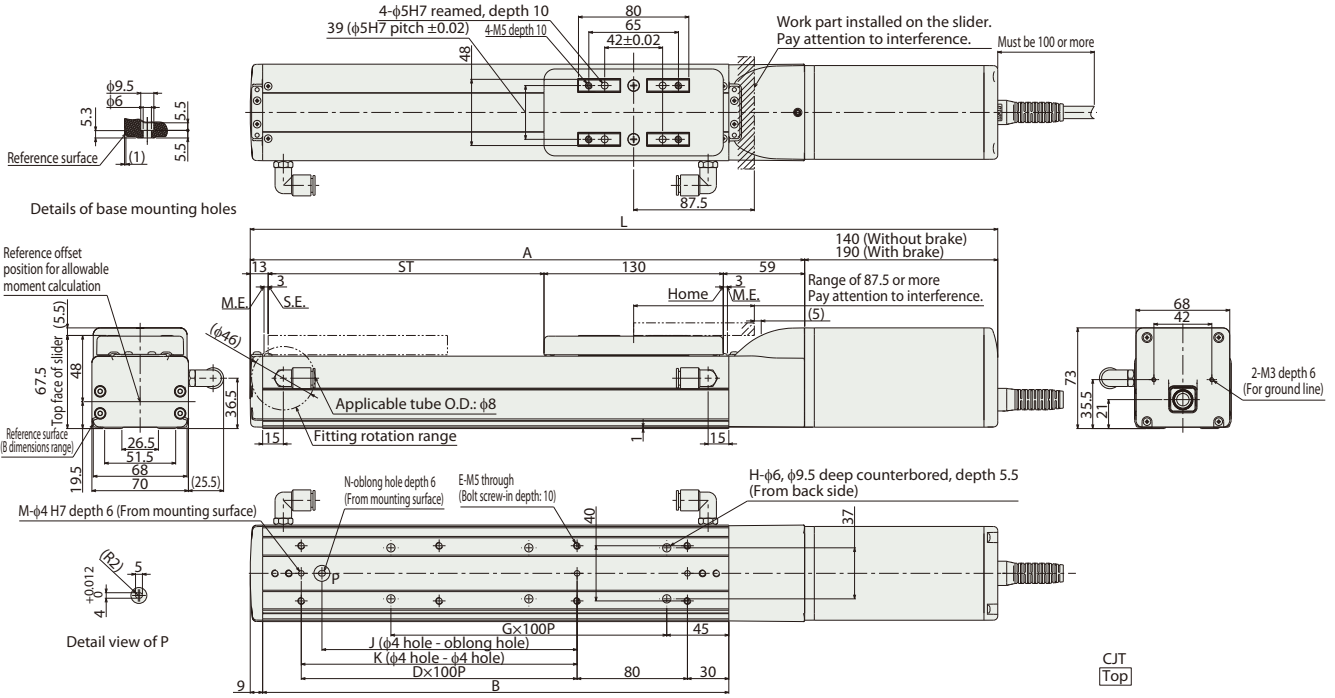

■ Dimensions and Mass by Stroke

Stroke	50	100	150	200	250	300	350	400	450	500	550	600	650	700	750	800	
L	RCP6CR w/o brake	392	442	492	542	592	642	692	742	792	842	892	942	992	1,042	1,092	1,142
	RCP6CR w/ brake	442	492	542	592	642	692	742	792	842	892	942	992	1,042	1,092	1,142	1,192
L	RCP6SCR w/o brake	417	467	517	567	617	667	717	767	817	867	917	967	1,017	1,067	1,117	1,167
	RCP6SCR w/ brake	467	517	567	617	667	717	767	817	867	917	967	1,017	1,067	1,117	1,167	1,217
A	252	302	352	402	452	502	552	602	652	702	752	802	852	902	952	1,002	
B	188	238	288	338	388	438	488	538	588	638	688	738	788	838	888	938	
D	0	1	1	2	2	3	3	4	4	5	5	6	6	7	7	8	
E	4	6	6	8	8	10	10	12	12	14	14	16	16	18	18	20	
G	1	1	2	2	3	3	4	4	5	5	6	6	7	7	8	8	
H	4	4	6	6	8	8	10	10	12	12	14	14	16	16	18	18	
J	0	85	85	185	185	285	285	385	385	485	485	585	585	685	685	785	
K	0	0	100	200	200	300	300	400	400	500	500	600	600	700	700	800	
M	2	2	3	3	3	3	3	3	3	3	3	3	3	3	3	3	
N	0	1	1	1	1	1	1	1	1	1	1	1	1	1	1	1	
Mass (kg)	RCP6CR w/o brake	3.6	3.8	4.0	4.3	4.5	4.7	4.9	5.2	5.4	5.6	5.9	6.1	6.3	6.5	6.8	7.0
	RCP6CR w/ brake	4.0	4.2	4.5	4.7	4.9	5.1	5.4	5.6	5.8	6.1	6.3	6.5	6.7	7.0	7.2	7.4
Mass (kg)	RCP6SCR w/o brake	3.8	4.0	4.2	4.4	4.7	4.9	5.1	5.3	5.6	5.8	6.0	6.3	6.5	6.7	6.9	7.2
	RCP6SCR w/ brake	4.2	4.4	4.6	4.9	5.1	5.3	5.6	5.8	6.0	6.2	6.5	6.7	6.9	7.1	7.4	7.6

② Applicable Controllers

The RCP6 series actuators can be operated by the controllers indicated below. Please select the type depending on your intended use. * Please refer to P.271 for more information about the built-in controller of RCP6S series.

Name	External view	Max. number of controlled axes	Input power	Control method				Maximum number of positioning points	Reference page
				Positioner	Pulse train	Program	Network * Option		
PCON-CYB/PLB/POB		1	DC24V	●	●	—	Network cannot be selected	64	Please contact IAI for more information.
PCON-CB/CGB		1		* Option	* Option	—	DeviceNet MECHATROLINK CC-Link EtherCAT EtherNet/IP PROFINET CompoNet	512 (768 for network spec.)	See P.255
MCON-C/CG		8		This model is network-compatible only.				Note: The type of compatible networks will vary depending on the controller. Please refer to reference page for more information.	256
MCON-LC/LCG		6		—	—	●	256		Please contact IAI for more information.
MSEL-PC/PG		4	Single-phase 100 ~ 230 VAC	—	—	●	30,000	Please contact IAI for more information.	
RCM-P6PC		1	Usable within the RCP6S Gateway system.				768	See P.279	

* For the MCON controller, high-output enabled operation is only available if "high-output setting" is selected as an option. The maximum connectable axes with high-output enabled are C: 4 and LC: 3.

Foreword
Slider Type
Wide Slider Type
Rod Type
Radial Cylinder
Wide Radial Cylinder
Table Type
Cleanroom Slider
Cleanroom Wide Slider
Dust/Splash-Proof Rod
Dust/Splash-Proof Radial Cylinder
Dust/Splash-Proof Wide Radial Cylinder
Options
Reference Data
Controller

RCP6(S)CR-SA8C



Model Specification Items

Series	SA8C	Encoder Type	WA	Motor Type	56SP	Lead	Stroke	Applicable Controller/I/O Type	Cable Length	Options
RCP6CR: Separate Controller RCP6SCR: Built-in Controller		WA: Battery-less Absolute		56SP: High Thrust Stepper Motor 56□ Size	30:30mm 20:20mm 10:10mm 5:5mm	50:50mm 1100:100mm (Every 50mm)	[RCP6] P4: PCON-CFB/CGFB [RCP6S] SE: SIO Type	N: None P: 1m S: 3m M: 5m XC□□: Specified Length R□□: Robot Cable	Please refer to the options table below.	

* RCP6 does not include a controller. RCP6S includes a built-in controller.
* Please refer to P.18 for more information about the model specification items.

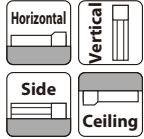

*Some limitations may apply to horizontal/side/ceiling mountings depending on the model. See page 204. Please contact IAI for more information.



- POINT Selection Notes**
- (1) The maximum acceleration/deceleration is 1G for horizontal, and 0.5G for vertical use.
 - (2) The actuator specifications displays the payload's maximum value, but it will vary depending on the acceleration and speed. Please refer to the "Selection Guidelines" (Tables of Payload by Speed/Acceleration) on P.207 for more details.
 - (3) When performing push-motion operation, please confirm the push force of each model by checking the "Correlation diagrams of push force and current limit" on P.205.

Correlation Diagrams of Speed and Payload PCON connected.

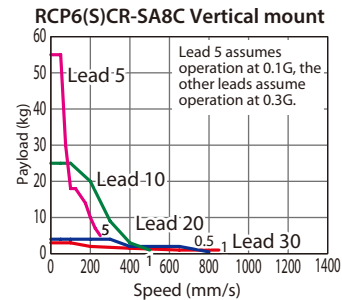
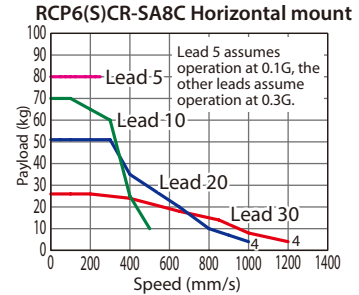

Actuator Specifications

Lead and Payload * Push force only available during push mode w / limited speed.

Model Number	Lead (mm)	Max. Payload		Max. Push Force (N)*
		Horizontal (kg)	Vertical (kg)	
RCP6(S)CR-SA8C-WA-56SP-30-①②③④	30	28	3	159
RCP6(S)CR-SA8C-WA-56SP-20-①②③④	20	60	4	239
RCP6(S)CR-SA8C-WA-56SP-10-①②③④	10	70	25	478
RCP6(S)CR-SA8C-WA-56SP-5-①②③④	5	80	55	956

Legend: ① Stroke ② Applicable controllers/I/O type ③ Cable length ④ Options

Stroke and Max Speed/Suction Amount (Unit: mm/s)

Lead (mm)	50~650 (Every 50mm)	700 (mm)	750 (mm)	800 (mm)	850 (mm)	900 (mm)	950 (mm)	1000 (mm)	1050 (mm)	1100 (mm)	Suction amount (N/min)
30	1,200 <850>	1,155 <850>	1,040 <850>	940 <850>	855 <850>	780	715	660	610	560	160
20	1,000 <800>	950 <800>	860 <800>	770	695	630	570	520	480	440	110
10	500	480	430	385	345	310	285	260	235	220	60
5	250	240	215	190	175	155	140	130	120	110	30

Values in brackets <> are for vertical use.

① Stroke

Stroke (mm)	RCP6CR	RCP6SCR	Stroke (mm)	RCP6CR	RCP6SCR
50	○	○	600	○	○
100	○	○	650	○	○
150	○	○	700	○	○
200	○	○	750	○	○
250	○	○	800	○	○
300	○	○	850	○	○
350	○	○	900	○	○
400	○	○	950	○	○
450	○	○	1000	○	○
500	○	○	1050	○	○
550	○	○	1100	○	○

④ Options

Name	Option Code	Reference Page
Brake	B	See P.189
Cable exit direction (Top)	CJT	See P.189
Cable exit direction (Right)	CJR	See P.189
Cable exit direction (Left)	CJL	See P.189
Cable exit direction (Bottom)	CJB	See P.189
Designated grease coating specification	G3/G4	
High-precision specification (*1)	HPR	See P.192
Non-motor end specification	NM	See P.194
Air suction joint in opposite position	VR	See P.195
Double slider specification (*2)	W	See P.196

(*1) When the lead is 20/30, it cannot be selected. Double slider specification cannot be selected.
(*2) Some leads cannot be selected. (See P. 248)

③ Cable Length

Cable Type	Cable Code	RCP6CR	RCP6SCR
Standard	P(1m)	○	○
	S(3m)	○	○
	M(5m)	○	○
Specified length	X06 (6m) ~X10 (10m)	○	○
	X11 (11m) ~X15 (15m)	○	○
	X16 (16m) ~X20 (20m)	○	○
Robot cable	R01 (1m) ~R03 (3m)	○	○
	R04 (4m) ~R05 (5m)	○	○
	R06 (6m) ~R10 (10m)	○	○
	R11 (11m) ~R15 (15m)	○	○
	R16 (16m) ~R20 (20m)	○	○

* Please refer to P. 267 and 283 for more information regarding the maintenance cables.

Actuator Specifications

Item	Description
Drive system	Ball screw φ16mm, rolled C10
Positioning repeatability (*1)	±0.01mm [±0.005mm]
Lost motion	0.1mm or less
Base	Material: Aluminum with white alumite treatment
Static allowable moment	Ma: 219N·m, Mb: 219N·m, Mc: 414N·m
Dynamic allowable moment (*2)	Ma: 77.0N·m, Mb: 77.0N·m, Mc: 146N·m
Cleanliness	Class 10 (Fed.Std.209D), class 2.5 or equivalent (ISO 14644-1 Standard)
Ambient operating temp. & humidity	0~40°C, 85% RH or less (Non-condensing)

* Reference for overhang load length: Ma: 400mm or less, Mb, Mc: 400mm or less
(*1) Values in [] are for high precision (for lead 5/10) specification.

(*2) Assumes a standard rated life of 5,000km. The service life will vary depending on operation and installation conditions.

Please refer to our website for more information regarding the directions of the allowable moment and overhang load length.

CAD drawings can be downloaded from our website.
www.intelligentactuator.com



*1 When the slider is returning to its home position, please be careful of interference from surrounding objects, as it will travel until it reaches the M.E.
M.E: Mechanical end S.E: Stroke end

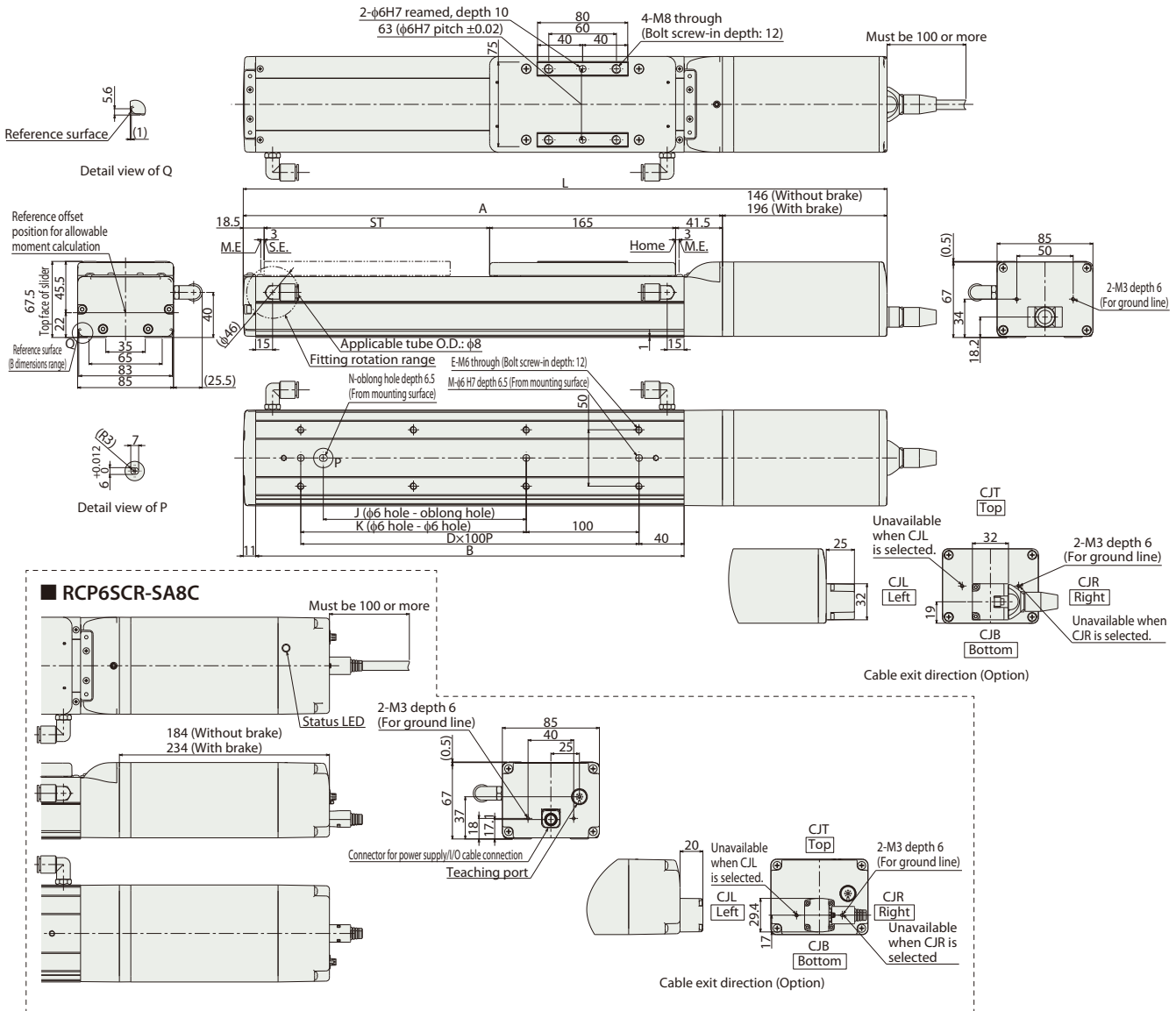

■ Dimensions and Mass by Stroke

Stroke	50	100	150	200	250	300	350	400	450	500	550	600	650	700	750	800	850	900	950	1000	1050	1100	
L	RCP6CR w/o brake	421	471	521	571	621	671	721	771	821	871	921	971	1,021	1,071	1,121	1,171	1,221	1,271	1,321	1,371	1,421	1,471
	RCP6CR w/ brake	471	521	571	621	671	721	771	821	871	921	971	1,021	1,071	1,121	1,171	1,221	1,271	1,321	1,371	1,421	1,471	1,521
R	RCP6SCR w/o brake	459	509	559	609	659	709	759	809	859	909	959	1,009	1,059	1,109	1,159	1,209	1,259	1,309	1,359	1,409	1,459	1,509
	RCP6SCR w/ brake	509	559	609	659	709	759	809	859	909	959	1,009	1,059	1,109	1,159	1,209	1,259	1,309	1,359	1,409	1,459	1,509	1,559
A	275	325	375	425	475	525	575	625	675	725	775	825	875	925	975	1,025	1,075	1,125	1,175	1,225	1,275	1,325	
B	230	280	330	380	430	480	530	580	630	680	730	780	830	880	930	980	1,030	1,080	1,130	1,180	1,230	1,280	
D	1	2	2	3	3	4	4	5	5	6	6	7	7	8	8	9	9	10	10	11	11	12	
E	4	6	6	8	8	10	10	12	12	14	14	16	16	18	18	20	20	22	22	24	24	26	
J	0	0	80	180	180	280	280	380	380	480	480	580	580	680	680	780	780	880	880	980	980	1,080	
K	0	100	100	200	200	300	300	400	400	500	500	600	600	700	700	800	800	900	900	1,000	1,000	1,100	
M	2	3	3	3	3	3	3	3	3	3	3	3	3	3	3	3	3	3	3	3	3	3	
N	0	0	1	1	1	1	1	1	1	1	1	1	1	1	1	1	1	1	1	1	1	1	
Mass (kg)	RCP6CR w/o brake	4.5	4.7	5.0	5.3	5.5	5.8	6.1	6.4	6.6	6.9	7.2	7.5	7.7	8.0	8.3	8.5	8.8	9.1	9.4	9.6	9.9	10.2
	RCP6CR w/ brake	5.0	5.2	5.5	5.8	6.1	6.3	6.6	6.9	7.1	7.4	7.7	8.0	8.2	8.5	8.8	9.1	9.3	9.6	9.9	10.1	10.4	10.7
	RCP6SCR w/o brake	4.7	4.9	5.2	5.5	5.8	6.0	6.3	6.6	6.9	7.1	7.4	7.7	7.9	8.2	8.5	8.8	9.0	9.3	9.6	9.9	10.1	10.4
	RCP6SCR w/ brake	5.2	5.5	5.7	6.0	6.3	6.5	6.8	7.1	7.4	7.6	7.9	8.2	8.5	8.7	9.0	9.3	9.5	9.8	10.1	10.4	10.6	10.9

② Applicable Controllers

The RCP6 series actuators can be operated by the controllers indicated below. Please select the type depending on your intended use.* Please refer to P.271 for more information about the built-in controller of RCP6S series.

Name	External view	Max. number of controlled axes	Input power	Control method			Maximum number of positioning points	Reference page
				Positioner	Pulse train	Program		
PCON-CFB/CGFB		1	DC24V	●	●	-	512 (768 for network spec.)	See P.255
				*Option	*Option			

Control method options: DeviceNet, CompoNet, EtherNet/IP, CC-Link, MECHATROLINK, EtherCAT, CANopen, Profibus, Modbus.

Foreword
Slider Type
Wide Slider Type
Rod Type
Radial Cylinder
Wide Radial Cylinder
Table Type
Cleanroom Slider
Cleanroom Wide Slider
Dust/Splash-Proof Rod
Dust/Splash-Proof Radial Cylinder
Dust/Splash-Proof Wide Radial Cylinder
Options
Reference Data
Controller

RCP6(S)CR-WSA10C



Model Specification Items

Series — Type — Encoder Type — Motor Type — Lead — Stroke — Applicable Controller/I/O Type — Cable Length — Options

RCP6CR: Separate Controller
RCP6SCR: Built-in Controller

WA: Battery-less Absolute
35P: Stepper Motor 35□ Size

16: 16mm
10: 10mm
5: 5mm
2.5: 2.5mm

50: 50mm
500: 500mm (Every 50mm)

[RCP6]
P3: PCON
MCON
MSEL
P5: RCM-P6PC
[RCP6S]
SE: SIO Type

N: None
P: 1m
S: 3m
M: 5m
XC□: Specified Length
R□□: Robot Cable

Please refer to the options table below.

* RCP6 does not include a controller. RCP6S includes a built-in controller.
* Please refer to P.18 for more information about the model specification items.

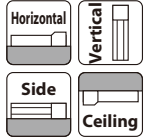

*Some limitations may apply to horizontal/side/ceiling mountings depending on the model. See page 204. Please contact IAI for more information.



- (1) The maximum acceleration/deceleration is 1G for horizontal, and 0.5G for vertical use.
- (2) The actuator specifications displays the payload's maximum value, but it will vary depending on the acceleration and speed. Please refer to the "Selection Guidelines" (Tables of Payload by Speed/Acceleration) on P.211 for more details.
- (3) When performing push-motion operation, please confirm the push force of each model by checking the "Correlation diagrams of push force and current limit" on P.205.

Correlation Diagrams of Speed and Payload

(1) High-output enabled with PCON/MCON/MSEL connected.

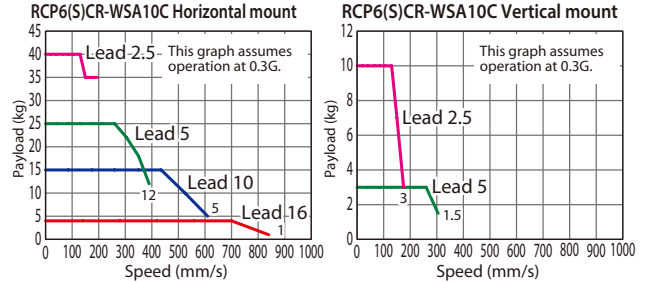

(2) High-output disabled with PCON/MCON connected

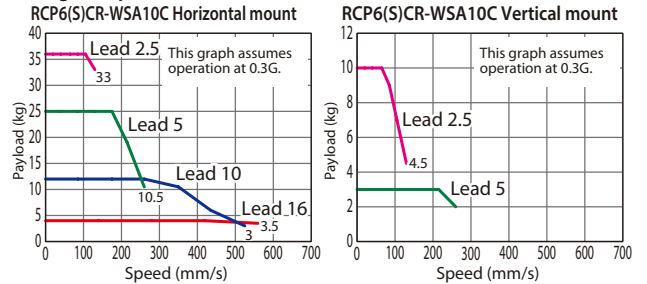

Actuator Specifications

Lead and Payload

* Push force only available during push mode w / limited speed.

Model Number	Lead (mm)	Connected Controller	Max. Payload		Max. Push Force (N)*
			Horizontal (kg)	Vertical (kg)	
RCP6(S)CR-WSA10C-WA-35P-16-①②③④	16	High-output Enabled	4	—	48
		High-output Disabled	4	—	
RCP6(S)CR-WSA10C-WA-35P-10-①②③④	10	High-output Enabled	15	—	77
		High-output Disabled	12	—	
RCP6(S)CR-WSA10C-WA-35P-5-①②③④	5	High-output Enabled	28	3	155
		High-output Disabled	25	3	
RCP6(S)CR-WSA10C-WA-35P-2.5-①②③④	2.5	High-output Enabled	40	10	310
		High-output Disabled	36	10	

Legend: ① Stroke ② Applicable controllers/I/O type ③ Cable length ④ Options

Stroke and Max Speed/Suction Amount

(Unit: mm/s)

Lead (mm)	Connected Controller	Max Speed					Suction amount (N/Lmin)
		50~300 (Every 50mm)	350 (mm)	400 (mm)	450 (mm)	500 (mm)	
16	High-output Enabled	840					105
	High-output Disabled	560					
10	High-output Enabled	610		590	490	415	60
	High-output Disabled	525					
5	High-output Enabled	390<350>	355<350>	290	245	205	30
	High-output Disabled	260					
2.5	High-output Enabled	195<175>	175	145	120	100	25
	High-output Disabled	130					

Values in brackets <> are for vertical use.

① Stroke

Stroke (mm)	RCP6CR	RCP6SCR	Stroke (mm)	RCP6CR	RCP6SCR
50	○	○	300	○	○
100	○	○	350	○	○
150	○	○	400	○	○
200	○	○	450	○	○
250	○	○	500	○	○

③ Cable Length

Cable Type	Cable Code	RCP6CR			RCP6SCR
		P3	P5	SE	
Standard	P(1m)	○	○	○	○
	S(3m)	○	○	○	○
	M(5m)	○	○	○	○
Specified length	X06 (6m) ~X10 (10m)	○	○	○	○
	X11 (11m) ~X15 (15m)	○	○	○	○
	X16 (16m) ~X20 (20m)	○	○	○	○
	R01 (1m) ~R03 (3m)	○	○	○	○
Robot cable	R04 (4m) ~R05 (5m)	○	○	○	○
	R06 (6m) ~R10 (10m)	○	○	○	○
	R11 (11m) ~R15 (15m)	○	○	○	○
	R16 (16m) ~R20 (20m)	○	○	○	○

* Please refer to P. 267 and 283 for more information regarding the maintenance cables.

④ Options

Name	Option Code	Reference Page
Brake	B	See P.189
Cable exit direction (Top)	CJT	See P.189
Cable exit direction (Right)	CJR	See P.189
Cable exit direction (Left) (*1)	CJL	See P.189
Cable exit direction (Bottom)	CJB	See P.189
Designated grease coating specification	G3/G4	
High-precision specification (*2)	HPR	See P.192
Non-motor end specification	NM	See P.194
Air suction joint in opposite position	VR	See P.195

(*1) RCP6SCR cannot be selected.

(*2) When the lead is 16, it cannot be selected.

Actuator Specifications

Item	Description
Drive system	Ball screw φ8mm, rolled C10
Positioning repeatability (*1)	±0.01mm (±0.005mm)
Lost motion	0.1mm or less
Base	Material: Aluminum with white alumite treatment
Static allowable moment	Ma: 271N·m, Mb: 271N·m, Mc: 533N·m
Dynamic allowable moment (*2)	Ma: 65.4N·m, Mb: 65.4N·m, Mc: 134N·m
Cleanliness	Class 10 (Fed.Std.209D), class 2.5 or equivalent (ISO 14644-1 Standard)
Ambient operating temp. & humidity	0~40°C, 85% RH or less (Non-condensing)

* Reference for overhang load length: Ma: 500mm or less, Mb, Mc: 500mm or less
(*1) Values in [] are for high precision (for lead 2.5/5/10) specification.

(*2) Assumes a standard rated life of 5,000km. The service life will vary depending on operation and installation conditions.

Please refer to our website for more information regarding the directions of the allowable moment and overhang load length.



*1 When the slider is returning to its home position, please be careful of interference from surrounding objects, as it will travel until it reaches the M.E.
M.E: Mechanical end S.E: Stroke end

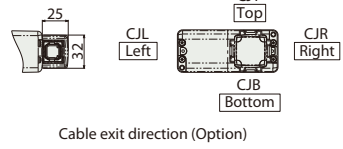
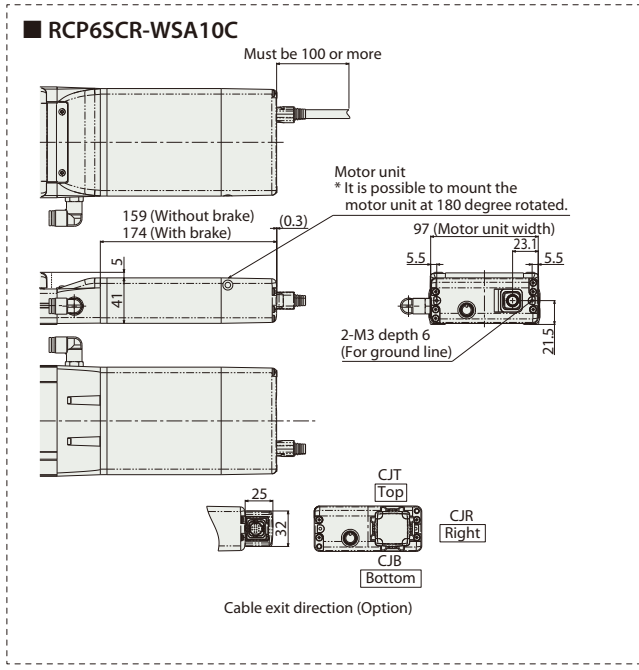
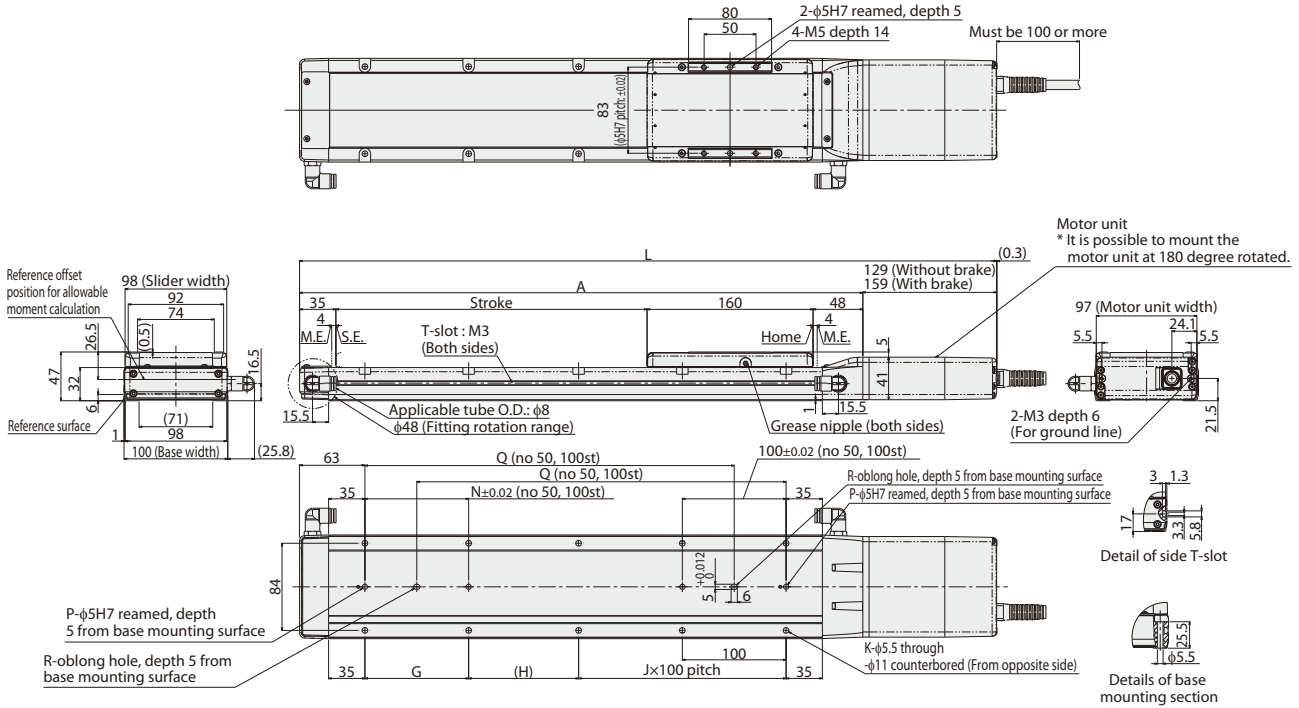

■ Dimensions and Mass by Stroke

		Stroke	50	100	150	200	250	300	350	400	450	500
L	RCP6CR	w/o brake	422	472	522	572	622	672	722	772	822	872
		w/ brake	452	502	552	602	652	702	752	802	852	902
	RCP6SCR	w/o brake	452	502	552	602	652	702	752	802	852	902
		w/ brake	467	517	567	617	667	717	767	817	867	917
A			293	343	393	443	493	543	593	643	693	743
G			-	-	100	100	100	100	100	100	100	100
H			156	206	56	106	56	106	56	106	56	106
J			0	0	1	1	2	2	3	3	4	4
K			4	4	8	8	10	10	12	12	14	14
N			-	-	100	100	100	100	100	100	100	100
P			1	1	2	2	2	2	2	2	2	2
Q			-	-	206	256	306	356	406	456	506	556
R			0	0	1	1	1	1	1	1	1	1
Mass (kg)	RCP6CR	w/o brake	2.9	3.1	3.4	3.6	3.8	4.1	4.3	4.6	4.8	5.0
		w/ brake	3.1	3.3	3.6	3.8	4.0	4.3	4.5	4.8	5.0	5.2
	RCP6SCR	w/o brake	3.0	3.2	3.5	3.7	3.9	4.2	4.4	4.7	4.9	5.1
		w/ brake	3.1	3.4	3.6	3.9	4.1	4.3	4.6	4.8	5.1	5.3

② Applicable Controllers

The RCP6 series actuators can be operated by the controllers indicated below. Please select the type depending on your intended use. * Please refer to P.271 for more information about the built-in controller of RCP6S series.

Name	External view	Max. number of controlled axes	Input power	Control method				Maximum number of positioning points	Reference page
				Positioner	Pulse train	Program	Network * Option		
PCON-CYB/PLB/POB		1	DC24V	●	●	-	Network cannot be selected	64	Please contact IAI for more information.
PCON-CB/CGB		1		* Option	* Option	-	MECHATROLINK EtherCAT 	512	See P.255
MCON-C/CG		8		This model is network-compatible only.					256
MCON-LC/LCG		6		-	-	●	256		Please contact IAI for more information.
MSEL-PC/PG		4	Single-phase 100 ~ 230 VAC	-	-	●	30,000	Please contact IAI for more information.	
RCM-P6PC		1	Usable within the RCP6S Gateway system.				768	See P.279	

* For the MCON controller, high-output enabled operation is only available if "high-output setting" is selected as an option. The maximum connectable axes with high-output enabled are C: 4 and LC: 3.

Foreword
Slider Type
Wide Slider Type
Rod Type
Radial Cylinder
Wide Radial Cylinder
Table Type
Cleanroom Slider
Cleanroom Wide Slider
Dust/Splash-Proof Rod
Dust/Splash-Proof Radial Cylinder*
Dust/Splash-Proof Wide Radial Cylinder
Options
Reference Data
Controller

RCP6(S)CR-WSA12C



Model Specification Items

Series	Type	Encoder Type	Motor Type	Lead	Stroke	Applicable Controller/I/O Type	Cable Length	Options
RCP6CR: Separate Controller RCP6SCR: Built-in Controller	WSA12C	WA	42P	20 :20mm 12 :12mm 6 : 6mm 3 : 3mm	50:50mm 800:800mm (Every 50mm)	[RCP6] P3 : PCON MCON MSEL P5 : RCM-P6PC [RCP6S] SE: SIO Type	N : None P : 1m S : 3m M : 5m XC : Specified Length R : Robot Cable	Please refer to the options table below.

* RCP6 does not include a controller. RCP6S includes a built-in controller.
* Please refer to P.18 for more information about the model specification items.

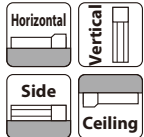

*Some limitations may apply to horizontal/side/ceiling mountings depending on the model. See page 204. Please contact IAI for more information.

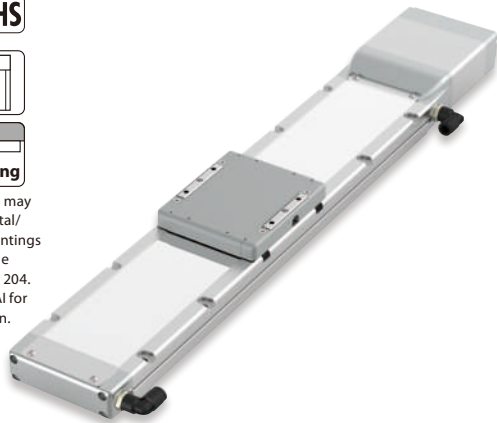

- The maximum acceleration/deceleration is 1G for horizontal, and 0.5G for vertical use.
- The actuator specifications displays the payload's maximum value, but it will vary depending on the acceleration and speed. Please refer to the "Selection Guidelines" (Tables of Payload by Speed/Acceleration) on P.211 for more details.
- When performing push-motion operation, please confirm the push force of each model by checking the "Correlation diagrams of push force and current limit" on P.205.
- Depending on the ambient operating temperature, duty control is necessary for the RCP6S (built-in controller type) with lead 3/6. Please refer to P.247 for more information.

Correlation Diagrams of Speed and Payload

(1) High-output enabled with PCON/MCON/MSEL connected.

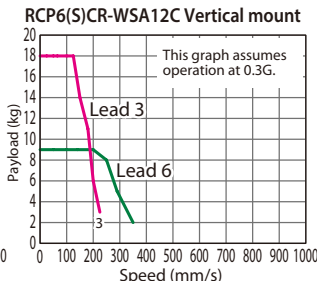
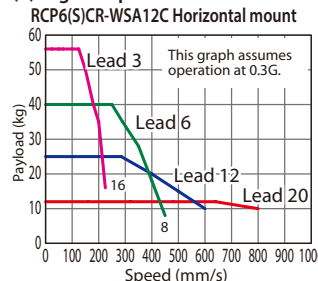

(2) High-output disabled with PCON/MCON connected

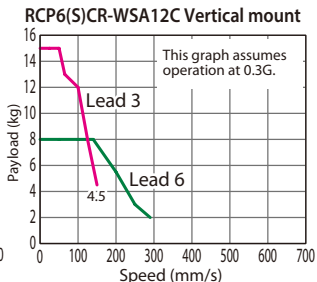
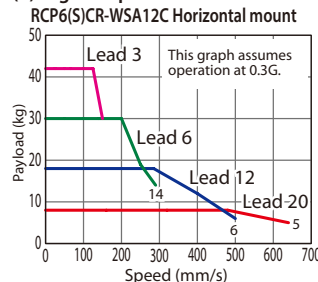

Actuator Specifications

Lead and Payload

* Push force only available during push mode w / limited speed.

Model Number	Lead (mm)	Connected Controller	Max. Payload		Max. Push Force (N)*
			H(kg)	V(kg)	
RCP6(S)CR-WSA12C-WA-42P-20-①②③④	20	High-output Enabled	12	-	56
		High-output Disabled	8	-	
RCP6(S)CR-WSA12C-WA-42P-12-①②③④	12	High-output Enabled	25	-	93
		High-output Disabled	18	-	
RCP6(S)CR-WSA12C-WA-42P-6-①②③④	6	High-output Enabled	40	9	185
		High-output Disabled	30	8	
RCP6(S)CR-WSA12C-WA-42P-3-①②③④	3	High-output Enabled	60	18	370
		High-output Disabled	42	15	

Legend: ① Stroke ② Applicable controllers/I/O type ③ Cable length ④ Options

Stroke and Max Speed/Suction Amount

(Unit: mm/s)

Lead (mm)	Connected Controller	Max Speed											Suction amount (N/min)			
		50~350 (Every 50mm)	400 (mm)	450 (mm)	500 (mm)	550 (mm)	600 (mm)	650 (mm)	700 (mm)	750 (mm)	800 (mm)					
20	High-output Enabled	800										740 650 580 520	130			
	High-output Disabled	640										580 520				
12	High-output Enabled	600		535		465		405		355		315		285		80
	High-output Disabled	500		465		405		355		315		285				
6	High-output Enabled	450<400>	435<400>	365	310	265	230	200	175	155	140			40		
	High-output Disabled	290		265		230		200		175		155				
3	High-output Enabled	225	215	180	150	130	115	100	85	75	70			25		
	High-output Disabled	150		130		115		100		85		75				

Values in brackets <> are for vertical use.

① Stroke

Stroke (mm)	RCP6CR	RCP6SCR	Stroke (mm)	RCP6CR	RCP6SCR
50	○	○	450	○	○
100	○	○	500	○	○
150	○	○	550	○	○
200	○	○	600	○	○
250	○	○	650	○	○
300	○	○	700	○	○
350	○	○	750	○	○
400	○	○	800	○	○

③ Cable Length

Cable Type	Cable Code	RCP6CR			RCP6SCR
		P3	P5	SE	
Standard	P(1m)	○	○	○	○
	S(3m)	○	○	○	○
	M(5m)	○	○	○	○
Specified length	X06 (6m) ~X10 (10m)	○	○	○	○
	X11 (11m) ~X15 (15m)	○	○	○	○
	X16 (16m) ~X20 (20m)	○	○	○	○
	R01 (1m) ~R03 (3m)	○	○	○	○
Robot cable	R04 (4m) ~R05 (5m)	○	○	○	○
	R06 (6m) ~R10 (10m)	○	○	○	○
	R11 (11m) ~R15 (15m)	○	○	○	○
	R16 (16m) ~R20 (20m)	○	○	○	○

* Please refer to P. 267 and 283 for more information regarding the maintenance cables.

④ Options

Name	Option Code	Reference Page
Brake	B	See P.189
Cable exit direction (Top)	CJT	See P.189
Cable exit direction (Right)	CJR	See P.189
Cable exit direction (Left)	CJL	See P.189
Cable exit direction (Bottom)	CJB	See P.189
Designated grease coating specification	G3/G4	
High-precision specification*	HPR	See P.192
Non-motor end specification	NM	See P.194
Air suction joint in opposite position	VR	See P.195

* When the lead is 20, it cannot be selected.

Actuator Specifications

Item	Description
Drive system	Ball screw φ10mm, rolled C10
Positioning repeatability (*1)	±0.01mm [±0.005mm]
Lost motion	0.1mm or less
Base	Material: Aluminum with white alumite treatment
Static allowable moment	Ma: 311N·m, Mb: 311N·m, Mc: 827N·m
Dynamic allowable moment (*2)	Ma: 87.5N·m, Mb: 87.5N·m, Mc: 233N·m
Cleanliness	Class 10 (Fed.Std.209D), class 2.5 or equivalent (ISO 14644-1 Standard)
Ambient operating temp. & humidity	0~40°C, 85% RH or less (Non-condensing)

* Reference for overhang load length: Ma: 450mm or less, Mb, Mc: 450mm or less

(*1) Values in [] are for high precision (for lead 3/6/12) specification.

(*2) Assumes a standard rated life of 5,000km. The service life will vary depending on operation and installation conditions.

Please refer to our website for more information regarding the directions of the allowable moment and overhang load length.



*1 When the slider is returning to its home position, please be careful of interference from surrounding objects, as it will travel until it reaches the M.E.
M.E: Mechanical end S.E: Stroke end

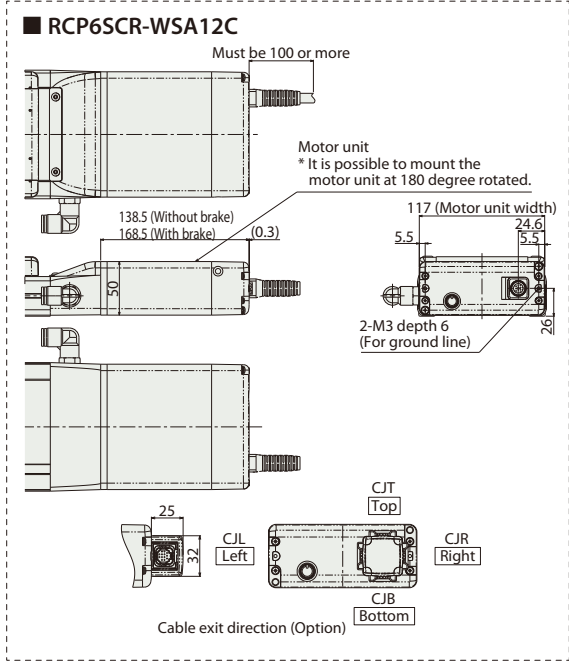
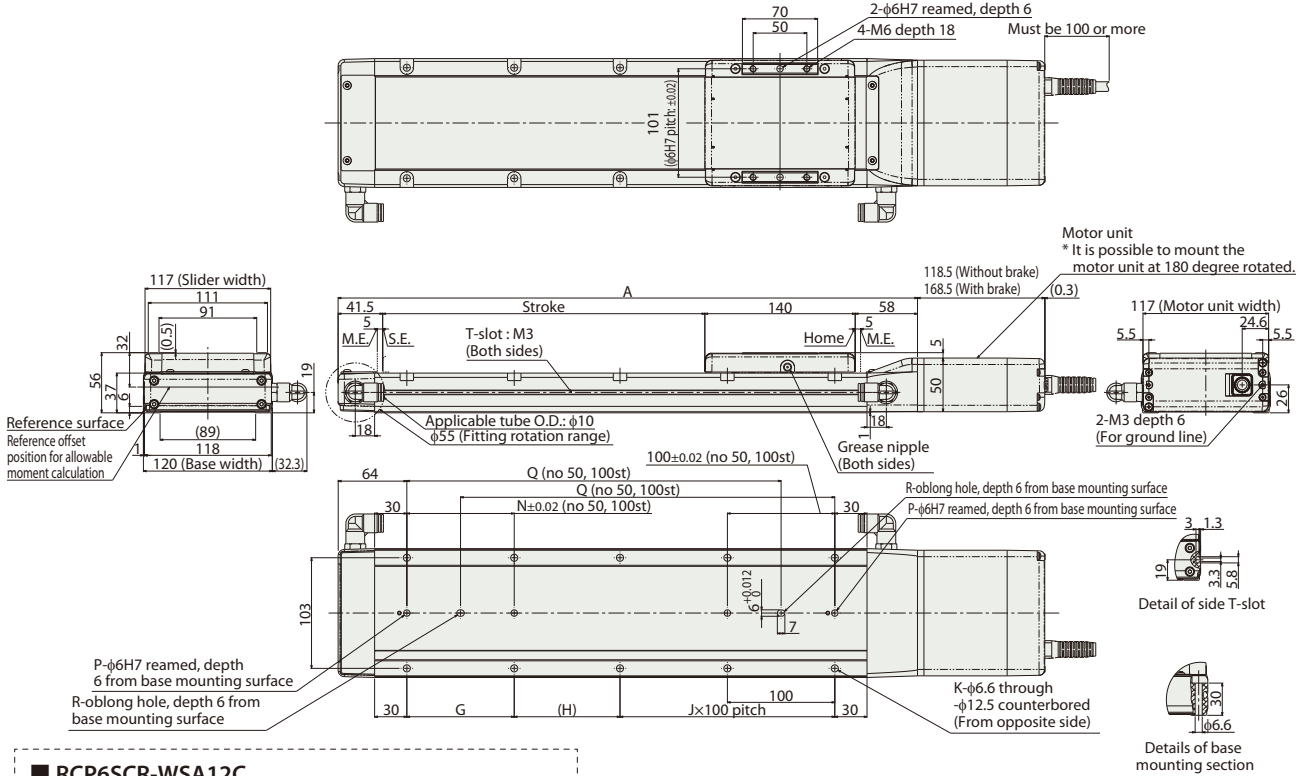

Dimensions and Mass by Stroke

Stroke	50	100	150	200	250	300	350	400	450	500	550	600	650	700	750	800	
L	RCP6CR w/o brake	408	458	508	558	608	658	708	758	808	858	908	958	1,008	1,058	1,108	1,158
	RCP6SCR w/o brake	428	478	528	578	628	678	728	778	828	878	928	978	1,028	1,078	1,128	1,178
A	289.5	339.5	389.5	439.5	489.5	539.5	589.5	639.5	689.5	739.5	789.5	839.5	889.5	939.5	989.5	1,039.5	
G	-	-	100	100	100	100	100	100	100	100	100	100	100	100	100	100	
H	148.5	198.5	48.5	98.5	48.5	98.5	48.5	98.5	48.5	98.5	48.5	98.5	48.5	98.5	48.5	98.5	
J	0	0	1	1	2	2	3	3	4	4	5	5	6	6	7	7	
K	4	4	8	8	10	10	12	12	14	14	16	16	18	18	20	20	
N	-	-	100	100	100	100	100	100	100	100	100	100	100	100	100	100	
P	1	1	2	2	2	2	2	2	2	2	2	2	2	2	2	2	
Q	-	-	198.5	248.5	298.5	348.5	398.5	448.5	498.5	548.5	598.5	648.5	698.5	748.5	798.5	848.5	
R	0	0	1	1	1	1	1	1	1	1	1	1	1	1	1	1	
Mass (kg)	RCP6CR w/o brake	3.8	4.1	4.4	4.8	5.1	5.4	5.8	6.1	6.4	6.8	7.1	7.4	7.8	8.1	8.4	
	RCP6SCR w/o brake	4.0	4.4	4.7	5.0	5.4	5.7	6.0	6.4	6.7	7.1	7.4	7.7	8.1	8.4	8.7	
	RCP6CR w/ brake	3.8	4.2	4.5	4.8	5.2	5.5	5.8	6.2	6.5	6.8	7.2	7.5	7.8	8.2	8.5	
	RCP6SCR w/ brake	4.1	4.4	4.7	5.1	5.4	5.7	6.1	6.4	6.7	7.1	7.4	7.8	8.1	8.4	8.8	

② Applicable Controllers

The RCP6 series actuators can be operated by the controllers indicated below. Please select the type depending on your intended use. * Please refer to P.271 for more information about the built-in controller of RCP6S series.

Name	External view	Max. number of controlled axes	Input power	Control method				Maximum number of positioning points	Reference page
				Positioner	Pulse train	Program	Network * Option		
PCON-CYB/PLB/POB		1	DC24V	●	●	-	Network cannot be selected	64	Please contact IAI for more information.
PCON-CB/CGB		1		* Option	* Option	-		512	See P.255
MCON-C/CG		8		This model is network-compatible only.				256	Please contact IAI for more information.
MCON-LC/LCG		6		-	-	●	256	Please contact IAI for more information.	
MSEL-PC/PG		4	Single-phase 100 ~ 230 VAC	-	-	●	30,000	Please contact IAI for more information.	
RCM-P6PC		1		Usable within the RCP6S Gateway system.				768	See P.279

* For the MCON controller, high-output enabled operation is only available if "high-output setting" is selected as an option. The maximum connectable axes with high-output enabled are C: 4 and LC: 3.

Foreword
Slider Type
Wide Slider Type
Rod Type
Radial Cylinder
Wide Radial Cylinder
Table Type
Cleanroom Slider
Cleanroom Wide Slider
Dust/Splash-Proof Rod
Dust/Splash-Proof Radial Cylinder
Dust/Splash-Proof Wide Radial Cylinder
Options
Reference Data
Controller

RCP6(S)CR-WSA14C



Model Specification Items

Series — Type — Encoder Type — Motor Type — Lead — Stroke — Applicable Controller/I/O Type — Cable Length — Options

RCP6CR: Separate Controller
RCP6SCR: Built-in Controller

WA: Battery-less Absolute
56P: Stepper Motor 56□ Size

24 : 24mm
16 : 16mm
8 : 8mm
4 : 4mm

[RCP6]
P3 : PCON
MCON
MSEL
P5 : RCM-P6PC
[RCP6S]
SE: SIO Type

N : None
P : 1m
S : 3m
M : 5m
XC□ : Specified Length
R□ : Robot Cable

Please refer to the options table below.

* RCP6 does not include a controller. RCP6S includes a built-in controller.
* Please refer to P.18 for more information about the model specification items.

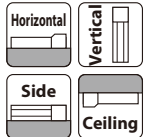

*Some limitations may apply to horizontal/side/ceiling mountings depending on the model. See page 204. Please contact IAI for more information.



- (1) The maximum acceleration/deceleration is 1G for horizontal, and 0.5G for vertical use.
- (2) The actuator specifications displays the payload's maximum value, but it will vary depending on the acceleration and speed. Please refer to the "Selection Guidelines" (Tables of Payload by Speed/Acceleration) on P.211 for more details.
- (3) When performing push-motion operation, please confirm the push force of each model by checking the "Correlation diagrams of push force and current limit" on P.205.
- (4) Depending on the ambient operating temperature, duty control is necessary for the RCP6S (built-in controller type) with lead 4/8/16. Please refer to P.247 for more information.

Correlation Diagrams of Speed and Payload

(1) High-output enabled with PCON/MCON/MSEL connected.

RCP6(S)CR-WSA14C Horizontal mount

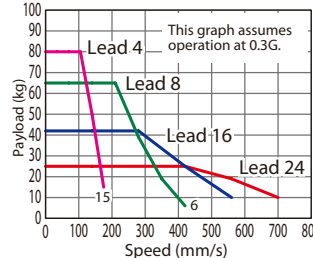

RCP6(S)CR-WSA14C Vertical mount

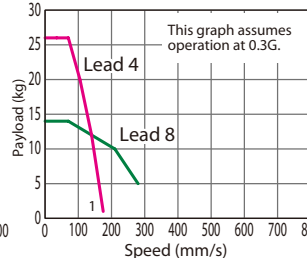

(2) High-output disabled with PCON/MCON connected

RCP6(S)CR-WSA14C Horizontal mount

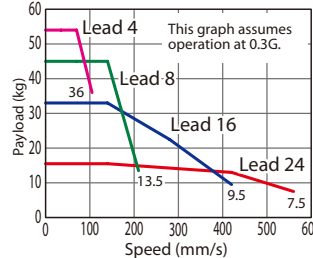

RCP6(S)CR-WSA14C Vertical mount

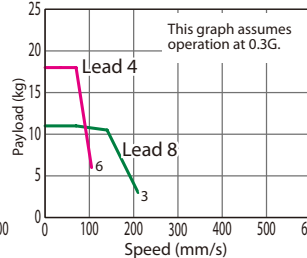

Actuator Specifications

Lead and Payload

* Push force only available during push mode w / limited speed.

Model Number	Lead (mm)	Connected Controller	Max. Payload		Max. Push Force (N)*
			H(kg)	V(kg)	
RCP6(S)CR-WSA14C-WA-56P-24-①-②-③-④	24	High-output Enabled	25	—	112
		High-output Disabled	15.5	—	
RCP6(S)CR-WSA14C-WA-56P-16-①-②-③-④	16	High-output Enabled	50	—	168
		High-output Disabled	33	—	
RCP6(S)CR-WSA14C-WA-56P-8-①-②-③-④	8	High-output Enabled	65	14	336
		High-output Disabled	45	11	
RCP6(S)CR-WSA14C-WA-56P-4-①-②-③-④	4	High-output Enabled	80	26	673
		High-output Disabled	54	18	

Legend: ① Stroke ② Applicable controllers/I/O type ③ Cable length ④ Options

Stroke and Max Speed/Suction Amount

(Unit: mm/s)

Lead (mm)	Connected Controller	Max Speed								Suction amount (N/L/min)
		50~500 (Every 50mm)	550 (mm)	600 (mm)	650 (mm)	700 (mm)	750 (mm)	800 (mm)		
24	High-output Enabled	700								105
	High-output Disabled	560								
16	High-output Enabled	560				550 490 440				80
	High-output Disabled	420								
8	High-output Enabled	420<350>	400<350>	350	305	270	240	215	45	
	High-output Disabled	210								
4	High-output Enabled	210<175>	200<175>	170	150	135	120	105	25	
	High-output Disabled	105								

Values in brackets <> are for vertical use.

① Stroke

Stroke (mm)	RCP6CR	RCP6SCR	Stroke (mm)	RCP6CR	RCP6SCR
50	○	○	450	○	○
100	○	○	500	○	○
150	○	○	550	○	○
200	○	○	600	○	○
250	○	○	650	○	○
300	○	○	700	○	○
350	○	○	750	○	○
400	○	○	800	○	○

③ Cable Length

Cable Type	Cable Code	RCP6CR		RCP6SCR
		P3	P5	SE
Standard	P(1m)	○	○	○
	S(3m)	○	○	○
	M(5m)	○	○	○
Specified length	X06 (6m) ~X10 (10m)	○	○	○
	X11 (11m) ~X15 (15m)	○	○	○
	X16 (16m) ~X20 (20m)	○	○	○
	R01 (1m) ~R03 (3m)	○	○	○
Robot cable	R04 (4m) ~R05 (5m)	○	○	○
	R06 (6m) ~R10 (10m)	○	○	○
	R11 (11m) ~R15 (15m)	○	○	○
	R16 (16m) ~R20 (20m)	○	○	○
		○	○	○
		○	○	○

* Please refer to P. 267 and 283 for more information regarding the maintenance cables.

④ Options

Name	Option Code	Reference Page
Brake	B	See P.189
Cable exit direction (Top)	CJT	See P.189
Cable exit direction (Right)	CJR	See P.189
Cable exit direction (Left)	CJL	See P.189
Cable exit direction (Bottom)	CJB	See P.189
Designated grease coating specification	G3/G4	
High-precision specification *	HPR	See P.192
Non-motor end specification	NM	See P.194
Air suction joint in opposite position	VR	See P.195

* When the lead is 16/24, it cannot be selected.

Actuator Specifications

Item	Description
Drive system	Ball screw φ12mm, rolled C10
Positioning repeatability (*1)	±0.01mm [±0.005mm]
Lost motion	0.1mm or less
Base	Material: Aluminum with white alumite treatment
Static allowable moment	Ma: 462N·m, Mb: 462N·m, Mc: 1,170N·m
Dynamic allowable moment (*2)	Ma: 122N·m, Mb: 122N·m, Mc: 308N·m
Cleanliness	Class 10 (Fed.Std.209D), class 2.5 or equivalent (ISO 14644-1 Standard)
Ambient operating temp. & humidity	0~40°C, 85% RH or less (Non-condensing)

* Reference for overhang load length: Ma: 550mm or less, Mb, Mc: 550mm or less

(*1) Values in [] are for high precision (for lead 4/8) specification.

(*2) Assumes a standard rated life of 5,000km. The service life will vary depending on operation and installation conditions.

Please refer to our website for more information regarding the directions of the allowable moment and overhang load length.



*1 When the slider is returning to its home position, please be careful of interference from surrounding objects, as it will travel until it reaches the M.E.
M.E: Mechanical end S.E: Stroke end

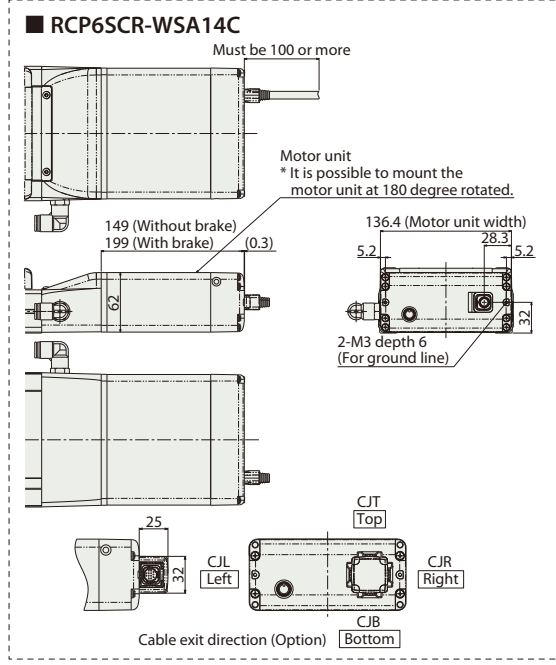
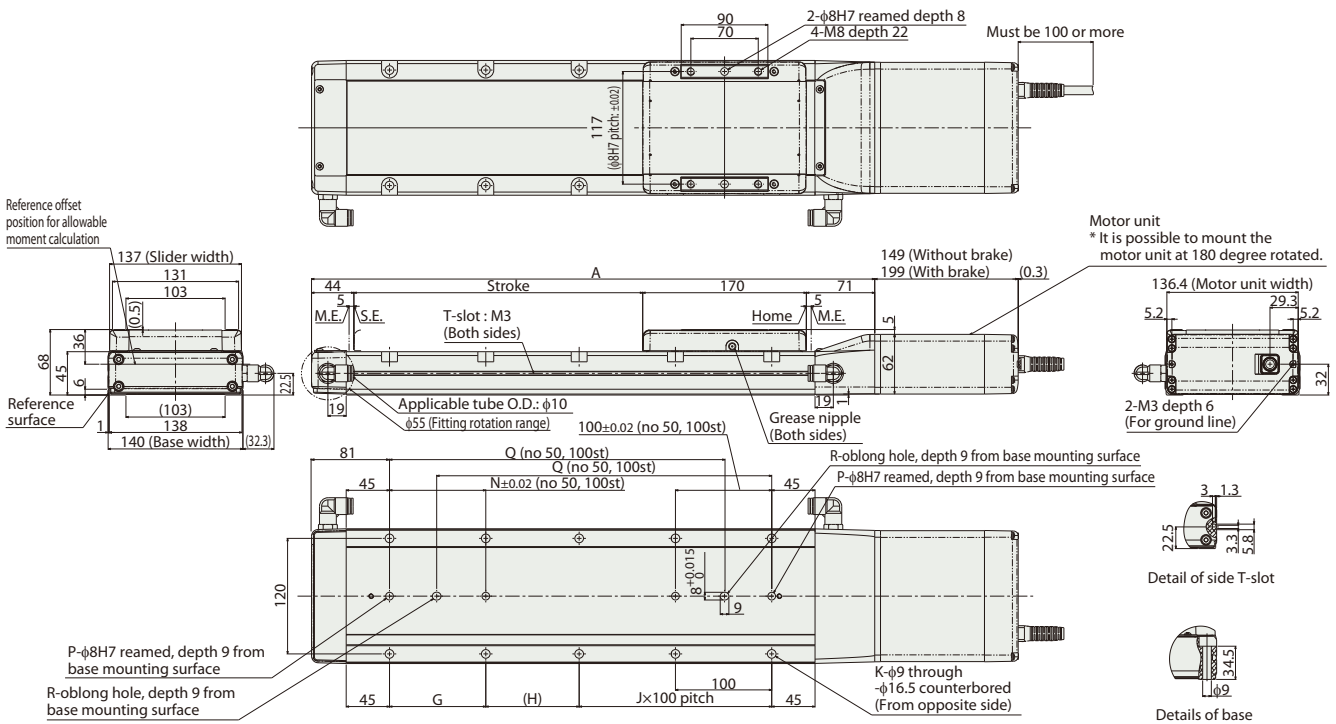

■ Dimensions and Mass by Stroke

Stroke	50	100	150	200	250	300	350	400	450	500	550	600	650	700	750	800	
L	RCP6CR w/brake	484	534	584	634	684	734	784	834	884	934	984	1,034	1,084	1,134	1,184	1,234
	RCP6SCR w/brake	484	534	584	634	684	734	784	834	884	934	984	1,034	1,084	1,134	1,184	1,234
A	335	385	435	485	535	585	635	685	735	785	835	885	935	985	1,035	1,085	
G	-	-	100	100	100	100	100	100	100	100	100	100	100	100	100	100	
H	147	197	47	97	47	97	47	97	47	97	47	97	47	97	47	97	
J	0	0	1	1	2	2	3	3	4	4	5	5	6	6	7	7	
K	4	4	8	8	10	10	12	12	14	14	16	16	18	18	20	20	
N	-	-	100	100	100	100	100	100	100	100	100	100	100	100	100	100	
P	1	1	2	2	2	2	2	2	2	2	2	2	2	2	2	2	
Q	-	-	198	248	298	348	398	448	498	548	598	648	698	748	798	848	
R	0	0	1	1	1	1	1	1	1	1	1	1	1	1	1	1	
Mass (kg)	RCP6CR w/o brake	6.6	7.0	7.5	8.0	8.5	8.9	9.4	9.9	10.4	10.9	11.3	11.8	12.3	12.8	13.2	13.7
	RCP6CR w/brake	7.0	7.5	8.0	8.5	8.9	9.4	9.9	10.4	10.9	11.3	11.8	12.3	12.8	13.2	13.7	14.2
	RCP6SCR w/o brake	6.6	7.1	7.6	8.0	8.5	9.0	9.5	9.9	10.4	10.9	11.4	11.9	12.3	12.8	13.3	13.8
	RCP6SCR w/brake	7.1	7.6	8.0	8.5	9.0	9.5	9.9	10.4	10.9	11.4	11.8	12.3	12.8	13.3	13.8	14.2

② Applicable Controllers

The RCP6 series actuators can be operated by the controllers indicated below. Please select the type depending on your intended use. * Please refer to P.271 for more information about the built-in controller of RCP6S series.

Name	External view	Max. number of controlled axes	Input power	Control method				Maximum number of positioning points	Reference page
				Positioner	Pulse train	Program	Network * Option		
PCON-CYB/PLB/POB		1	DC24V	●	●	-	Network cannot be selected	64	Please contact IAI for more information.
PCON-CB/CGB		1		* Option	* Option	-	DeviceNet MECHATROLINK CC-Link EtherCAT EtherNet/IP	512 (768 for network spec.)	See P.255
MCON-C/CG		8		This model is network-compatible only.				256	Please contact IAI for more information.
MCON-LC/LCG		6		-	-	●	CompoNet SSCNET III/H	256	Please contact IAI for more information.
MSEL-PC/PG		4	Single-phase 100 ~ 230 VAC	-	-	●	Note: The type of compatible networks will vary depending on the controller. Please refer to reference page for more information.	30,000	Please contact IAI for more information.
RCM-P6PC		1	Usable within the RCP6S Gateway system.				768	See P.279	

* For the MCON controller, high-output enabled operation is only available if "high-output setting" is selected as an option. The maximum connectable axes with high-output enabled are C: 4 and LC: 3.

Foreword
Slider Type
Wide Slider Type
Rod Type
Radial Cylinder
Wide Radial Cylinder
Table Type
Cleanroom Slider
Cleanroom Wide Slider
Dust/Splash-Proof Rod
Dust/Splash-Proof Radial Cylinder
Dust/Splash-Proof Wide Radial Cylinder
Options
Reference Data
Controller

RCP6(S)CR-WSA16C



Model Specification Items

Series	WSA16C	Encoder Type	WA	Motor Type	56SP	Lead	Stroke	Applicable Controller/I/O Type	Cable Length	Options
RCP6CR: Separate Controller RCP6SCR: Built-in Controller		WA: Battery-less Absolute		56SP: High Thrust Stepper Motor 56□ Size	20 :20mm 10 :10mm 5 : 5mm	50:50mm 1100:1100mm (Every 50mm)	[RCP6] P4 : PCON-CFB/ CGFB [RCP6S] SE: SIO Type	N : None P : 1m S : 3m M : 5m XC□ : Specified Length R□□ : Robot Cable	Please refer to the options table below.	

* RCP6 does not include a controller. RCP6S includes a built-in controller.
* Please refer to P.18 for more information about the model specification items.

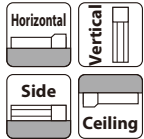

*Some limitations may apply to horizontal/side/ceiling mountings depending on the model. See page 204. Please contact IAI for more information.



POINT Selection Notes

- The maximum acceleration/deceleration is 1G for horizontal, and 0.5G for vertical use.
- The actuator specifications displays the payload's maximum value, but it will vary depending on the acceleration and speed. Please refer to the "Selection Guidelines" (Tables of Payload by Speed/Acceleration) on P.211 for more details.
- When performing push-motion operation, please confirm the push force of each model by checking the "Correlation diagrams of push force and current limit" on P.205.
- The service life of an actuator with lead 5 varies depending on the payload when using vertically. Please refer to P. 206 for more information.

Correlation Diagrams of Speed and Payload

PCON connected.

RCP6(S)CR-WSA16C Horizontal mount

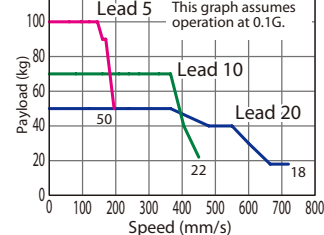

RCP6(S)CR-WSA16C Vertical mount

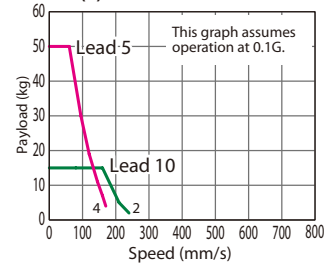

Actuator Specifications

Lead and Payload

* Push force only available during push mode w / limited speed.

Model Number	Lead (mm)	Max. Payload (kg)		Max. Push Force (N)*
		Horizontal	Vertical	
RCP6(S)CR-WSA16C-WA-56SP-20-①-②-③-④	20	50	-	239
RCP6(S)CR-WSA16C-WA-56SP-10-①-②-③-④	10	70	15	478
RCP6(S)CR-WSA16C-WA-56SP-5-①-②-③-④	5	100	50	956

Legend: ① Stroke ② Applicable controllers/I/O type ③ Cable length ④ Options

Stroke and Max Speed/Suction Amount

(Unit: mm/s)

Lead (mm)	50~650 (Every 50mm)	700 (mm)	750 (mm)	800 (mm)	850 (mm)	900 (mm)	950 (mm)	1000 (mm)	1050 (mm)	1100 (mm)	Suction amount (N/min)
20	720			715	645	590	535	490	450	415	65
10	450 <240>	440 <240>	395 <240>	355 <240>	320 <240>	290 <240>	265 <240>	240	225	205	30
5	195 <170>			175 <170>	160	145	130	120	110	100	20

Values in brackets <> are for vertical use.

① Stroke

Stroke (mm)	RCP6CR	RCP6SCR	Stroke (mm)	RCP6CR	RCP6SCR
50	○	○	600	○	○
100	○	○	650	○	○
150	○	○	700	○	○
200	○	○	750	○	○
250	○	○	800	○	○
300	○	○	850	○	○
350	○	○	900	○	○
400	○	○	950	○	○
450	○	○	1000	○	○
500	○	○	1050	○	○
550	○	○	1100	○	○

③ Cable Length

Cable Type	Cable Code	RCP6CR	RCP6SCR
Standard	P(1m)	○	○
	S(3m)	○	○
	M(5m)	○	○
Specified length	X06 (6m) ~X10 (10m)	○	○
	X11 (11m) ~X15 (15m)	○	○
	X16 (16m) ~X20 (20m)	○	○
	R01 (1m) ~R03 (3m)	○	○
Robot cable	R04 (4m) ~R05 (5m)	○	○
	R06 (6m) ~R10 (10m)	○	○
	R11 (11m) ~R15 (15m)	○	○
	R16 (16m) ~R20 (20m)	○	○

* Please refer to P. 267 and 283 for more information regarding the maintenance cables.

④ Options

Name	Option Code	Reference Page
Brake	B	See P.189
Cable exit direction (Top)	CJT	See P.189
Cable exit direction (Right)	CJR	See P.189
Cable exit direction (Left)	CJL	See P.189
Cable exit direction (Bottom)	CJB	See P.189
Designated grease coating specification	G3/G4	
High-precision specification *	HPR	See P.192
Non-motor end specification	NM	See P.194
Air suction joint in opposite position	VR	See P.195

* When the lead is 20, it cannot be selected.

Actuator Specifications

Item	Description
Drive system	Ball screw φ16mm, rolled C10
Positioning repeatability (*1)	±0.01mm [±0.005mm]
Lost motion	0.1mm or less
Base	Material: Aluminum with white alumite treatment
Static allowable moment	Ma: 642N·m, Mb: 642N·m, Mc: 1,610N·m
Dynamic allowable moment (*2)	Ma: 161N·m, Mb: 161N·m, Mc: 404N·m
Cleanliness	Class 10 (Fed.Std.209D), class 2.5 or equivalent (ISO 14644-1 Standard)
Ambient operating temp. & humidity	0~40°C, 85% RH or less (Non-condensing)

* Reference for overhang load length: Ma: 650mm or less, Mb, Mc: 650mm or less

(*1) Values in [] are for high precision (for lead 5/10) specification.

(*2) Assumes a standard rated life of 5,000km. The service life will vary depending on operation and installation conditions.

Please refer to our website for more information regarding the directions of the allowable moment and overhang load length.

CAD drawings can be downloaded from our website.
www.intelligentactuator.com



*1 When the slider is returning to its home position, please be careful of interference from surrounding objects, as it will travel until it reaches the M.E.
M.E: Mechanical end S.E: Stroke end

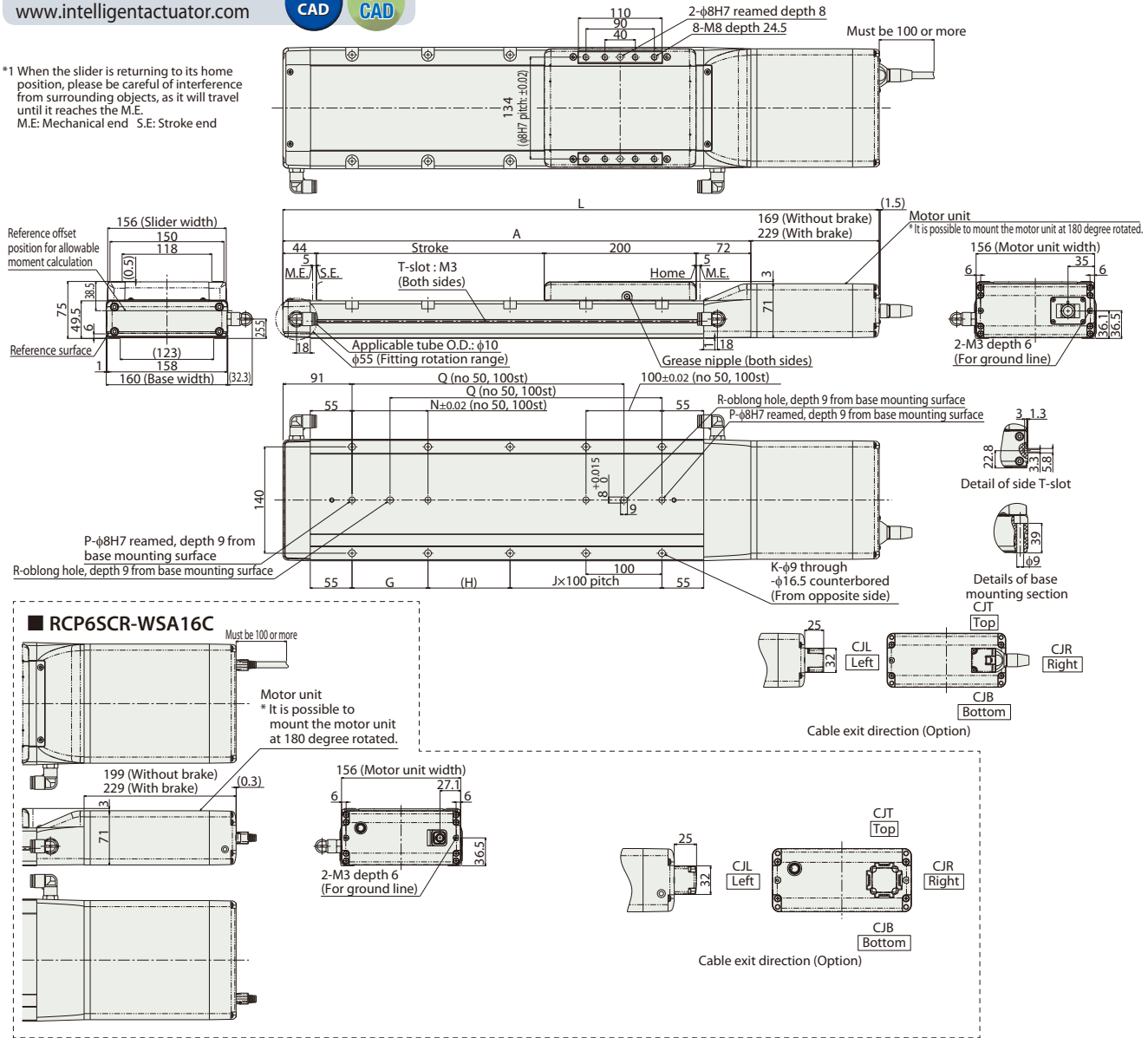

Dimensions and Mass by Stroke

Stroke	Stroke																							
	50	100	150	200	250	300	350	400	450	500	550	600	650	700	750	800	850	900	950	1000	1050	1100		
L	RCP6CR	w/o brake	535	585	635	685	735	785	835	885	935	985	1,035	1,085	1,135	1,185	1,235	1,285	1,335	1,385	1,435	1,485	1,535	1,585
	w/ brake	595	645	695	745	795	845	895	945	995	1,045	1,095	1,145	1,195	1,245	1,295	1,345	1,395	1,445	1,495	1,545	1,595	1,645	
A	RCP6SCR	w/o brake	565	615	665	715	765	815	865	915	965	1,015	1,065	1,115	1,165	1,215	1,265	1,315	1,365	1,415	1,465	1,515	1,565	1,615
	w/ brake	595	645	695	745	795	845	895	945	995	1,045	1,095	1,145	1,195	1,245	1,295	1,345	1,395	1,445	1,495	1,545	1,595	1,645	
G			-	-	100	100	100	100	100	100	100	100	100	100	100	100	100	100	100	100	100	100	100	100
H			158	208	58	108	58	108	58	108	58	108	58	108	58	108	58	108	58	108	58	108	58	108
J			0	0	1	1	2	2	3	3	4	4	5	5	6	6	7	7	8	8	9	9	10	10
K			4	4	8	8	10	10	12	12	14	14	16	16	18	18	20	20	22	22	24	24	26	26
N			-	-	100	100	100	100	100	100	100	100	100	100	100	100	100	100	100	100	100	100	100	100
P			1	1	2	2	2	2	2	2	2	2	2	2	2	2	2	2	2	2	2	2	2	2
Q			-	-	208	258	308	358	408	458	508	558	608	658	708	758	808	858	908	958	1,008	1,058	1,108	1,158
R			0	0	1	1	1	1	1	1	1	1	1	1	1	1	1	1	1	1	1	1	1	1
Mass (kg)	RCP6CR	w/o brake	9.0	9.6	10.2	10.8	11.4	12.0	12.6	13.2	13.8	14.4	15.0	15.7	16.2	16.9	17.4	18.1	18.7	19.3	19.9	20.5	21.1	21.7
		w/ brake	9.5	10.1	10.7	11.3	11.9	12.5	13.1	13.7	14.3	14.9	15.5	16.1	16.7	17.3	17.9	18.5	19.1	19.7	20.3	21.0	21.5	22.2
	RCP6SCR	w/o brake	9.2	9.8	10.4	11.0	11.6	12.2	12.8	13.4	14.0	14.6	15.2	15.8	16.4	17.0	17.6	18.2	18.8	19.4	20.0	20.6	21.2	21.8
		w/ brake	9.5	10.2	10.7	11.4	11.9	12.6	13.2	13.8	14.4	15.0	15.6	16.2	16.8	17.4	18.0	18.6	19.2	19.8	20.4	21.0	21.6	22.2

② Applicable Controllers

The RCP6 series actuators can be operated by the controllers indicated below. Please select the type depending on your intended use.* Please refer to P.271 for more information about the built-in controller of RCP6S series.

Name	External view	Max. number of controlled axes	Input power	Control method				Maximum number of positioning points	Reference page
				Positioner	Pulse train	Program	Network * Option		
PCON-CFB/CGFB		1	DC24V	* Option	* Option	-	DeviceNet CompoNet EtherNet/IP CC-Link MECHATROLINK EtherCAT PROFINET	512 (768 for network spec.)	See P.255

RCP6(S)W-RA4C

Dust/Splash-Proof Spec
Battery-less Absolute
Motor Unit Type
Coupled Motor
Body Width 40 mm
24v Stepper Motor

Model Specification Items	Series	Type	Encoder Type	Motor Type	Lead	Stroke	Applicable Controller/I/O Type	Cable Length	Options
	RA4C	WA	35P						
	RCP6W: Separate Controller RCP6SW: Built-in Controller	WA: Battery-less Absolute	35P: Stepper Motor 35□ Size	10 : 10mm 5 : 5mm 2.5 : 2.5mm	50:50mm 200:200mm (Every 50mm)	[RCP6W] P3 : PCON MCON MSEL P5 : RCM-P6PC [RCP6SW] SE: SIO Type	N : None P : 1m S : 3m M : 5m XC□ : Specified Length R□□ : Robot Cable	Please refer to the options table below.	

* RCP6 does not include a controller. RCP6S includes a built-in controller.
* Please refer to P.19 for more information about the model specification items.

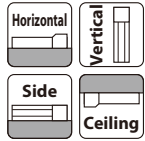

*Some limitations may apply to horizontal/side/ceiling mountings depending on the model. See page 204. Please contact IAI for more information.

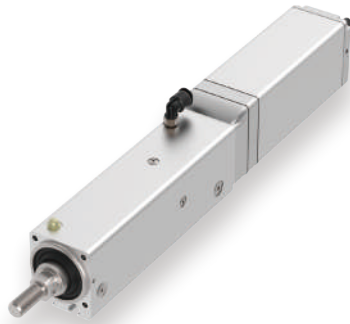

- POINT Selection Notes**
- The maximum acceleration/deceleration is 1G for horizontal, and 0.5G for vertical use.
 - The actuator specifications displays the payload's maximum value, but it will vary depending on the acceleration and speed. Please refer to the "Selection Guidelines" (Tables of Payload by Speed/Acceleration) on P.231 for more details.
 - The value of the horizontal payload assumes that there is an external guide. Please be aware that the anti-rotation stopper can be damaged when an external force is applied to the rod from any direction other than the moving direction.
 - Please refer to P205 for performing push-motion operation.
 - The cable joint connector is not splash-proofed, so it should be located where there is no splash.

Correlation Diagrams of Speed and Payload

If the ambient temperature is 5°C or below, the speed will be lower than when it exceeds 5°C.

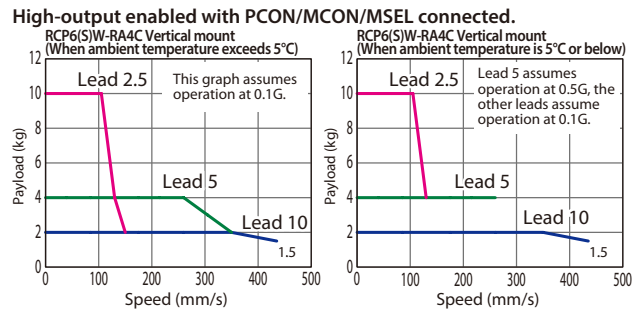
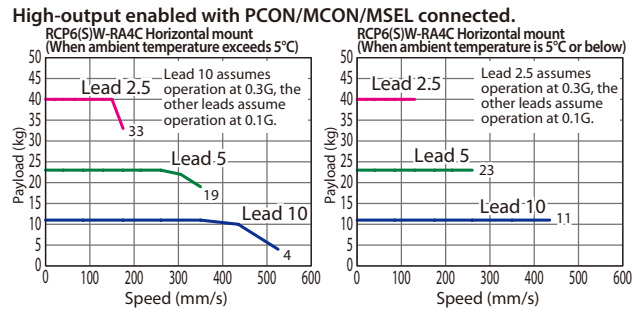

Actuator Specifications

Lead and Payload

* Push force only available during push mode w / limited speed.

Model Number	Lead (mm)	Max. Payload		Max. Push Force (N)*	Stroke (mm)
		Horizontal (kg)	Vertical (kg)		
RCP6(S)W-RA4C-WA-35P-10-①-②-③-④	10	11	2	77	50~200 (Every 50mm)
RCP6(S)W-RA4C-WA-35P-5-①-②-③-④	5	23	4	155	
RCP6(S)W-RA4C-WA-35P-2.5-①-②-③-④	2.5	40	10	310	

Legend: ① Stroke ② Applicable controllers/I/O type ③ Cable length ④ Options

Stroke and Max Speed

(Unit: mm/s)

Lead (mm)	50~200 (Every 50mm)
10	525 <435> [435]
5	350 [260]
2.5	175 <150> [130]

Values in brackets <> are for vertical use.
Values in brackets [] are when ambient temperature is 5°C or below.

① Stroke

Stroke (mm)	RCP6W	RCP6SW	Stroke (mm)	RCP6W	RCP6SW
50	○	○	150	○	○
100	○	○	200	○	○

④ Options

Name	Option Code	Reference Page
Actuator cable length 2m	Not specified	See P.197
Actuator cable length 5m	ACS	See P.197
Actuator cable length 10m	AC10	See P.197
Actuator cable length 15m	AC15	See P.197
Brake	B	See P.197
Cable exit direction (Bottom)	CJB	See P.197
Cable exit direction (Left)	CJL	See P.197
Cable exit direction (Right)	CJR	See P.197
Cable exit direction (Top)	CJT	See P.197
Flange	FL	See P.198
Foot bracket	FT	See P.199
Tip adapter (Internal thread)	NFA	See P.201
Non-motor end specification	NM	See P.202
T-slot nut bar	NTB	See P.202

③ Cable Length

Cable Type	Cable Code	RCP6W			RCP6SW
		P3	P5	SE	
Standard	P(1m)	○	○	○	
	S(3m)	○	○	○	
	M(5m)	○	○	○	
	X06(6m)~X10(10m)	○	○	○	
Specified length	X11(11m)~X15(15m)	○	○	○	
	X16(16m)~X18(18m)	○	○	○	
	R01(1m)~R03(3m)	○	○	○	
Robot cable	R04(4m)~R05(5m)	○	○	○	
	R06(6m)~R10(10m)	○	○	○	
	R11(11m)~R15(15m)	○	○	○	
	R16(16m)~R18(18m)	○	○	○	

* Select the length of the actuator cable and the actuator/controller connection cable so that the total is 20m or less.

* Please refer to P. 267 and 283 for more information regarding the maintenance cables.

Actuator Specifications

Item	Description
Drive system	Ball screw φ8mm, rolled C10
Positioning repeatability	±0.01mm
Lost motion	0.1mm or less
Rod	φ20mm
Allowable static torque on rod tip	1.0N·m
Max. angular displacement on rod tip (*1)	±1.0 deg.
Protective structure	IP65 (IEC 60529/JIS C 0920)
Ambient operating temp. & humidity	0~40°C, 85% RH or less (Non-condensing)

(*1) This is the displacement angle of the rod tip (initial reference value) when the rod is fully retracted and the allowable static torque is applied at the rod tip.

RCP6(S)W-RA6C

Dust/Splash-Proof Spec | Battery-less Absolute | Motor Unit Type | Coupled Motor | Body Width 58 mm | 24v Stepper Motor

Model Specification Items	Series	Type	Encoder Type	Motor Type	Lead	Stroke	Applicable Controller/I/O Type	Cable Length	Options
	RA6C	WA	42P						
	RCP6W: Separate Controller RCP6SW: Built-in Controller	WA: Battery-less Absolute	42P: Stepper Motor 42□□ Size	12 : 12mm 6 : 6mm 3 : 3mm	50:50mm 300:300mm (Every 50mm)	[RCP6W] P3 : PCON MCON MSEL P5 : RCM-P6PC [RCP6SW] SE: SIO Type	N : None P : 1m S : 3m M : 5m XC□□ : Specified Length R□□ : Robot Cable	Please refer to the options table below.	

* RCP6 does not include a controller. RCP6S includes a built-in controller.
* Please refer to P.19 for more information about the model specification items.

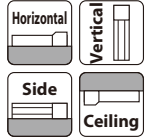

*Some limitations may apply to horizontal/side/ceiling mountings depending on the model. See page 204. Please contact IAI for more information.



- POINT Selection Notes**
- The maximum acceleration/deceleration is 1G for horizontal, and 0.5G for vertical use.
 - The actuator specifications displays the payload's maximum value, but it will vary depending on the acceleration and speed. Please refer to the "Selection Guidelines" (Tables of Payload by Speed/Acceleration) on P.231 for more details.
 - The value of the horizontal payload assumes that there is an external guide. Please be aware that the anti-rotation stopper can be damaged when an external force is applied to the rod from any direction other than the moving direction.
 - Please refer to P205 for performing push-motion operation.
 - Depending on the ambient operating temperature, duty control is necessary for the RCP6SW (built-in controller type) with lead 3/6. Please refer to P.247 for more information.
 - The cable joint connector is not splash-proofed, so it should be located where there is no splash.

Correlation Diagrams of Speed and Payload

If the ambient temperature is 5°C or below, the speed will be lower than when it exceeds 5°C.

High-output enabled with PCON/MCON/MSEL connected.

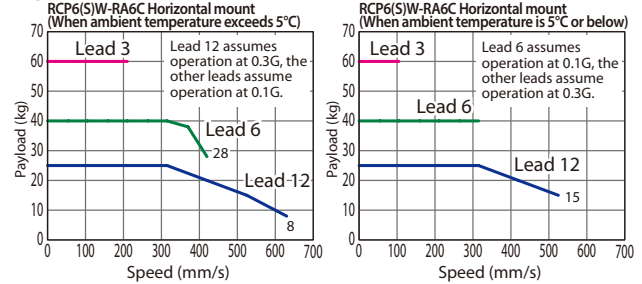

High-output enabled with PCON/MCON/MSEL connected.

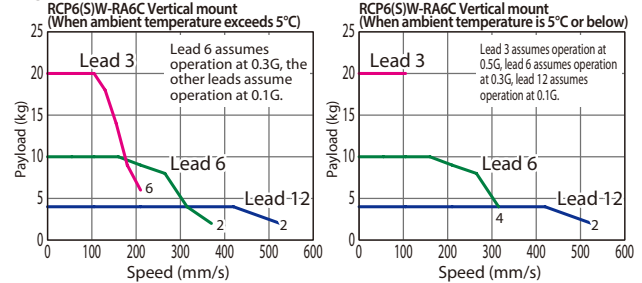

Actuator Specifications

Lead and Payload

* Push force only available during push mode w / limited speed.

Model Number	Lead (mm)	Max. Payload		Max. Push Force (N)*	Stroke (mm)
		Horizontal (kg)	Vertical (kg)		
RCP6(S)W-RA6C-WA-42P-12-①-②-③-④	12	25	4	93	50~300 (Every 50mm)
RCP6(S)W-RA6C-WA-42P-6-①-②-③-④	6	40	10	185	
RCP6(S)W-RA6C-WA-42P-3-①-②-③-④	3	60	20	370	

Legend: ① Stroke ② Applicable controllers/I/O type ③ Cable length ④ Options

Stroke and Max Speed

(Unit: mm/s)

Lead (mm)	50~300 (Every 50mm)
12	630 <525> [525]
6	420 <370> [315]
3	210 [105]

Values in brackets <> are for vertical use.
Values in brackets [] are when ambient temperature is 5°C or below.

① Stroke

Stroke (mm)	RCP6W	RCP6SW	Stroke (mm)	RCP6W	RCP6SW
50	○	○	200	○	○
100	○	○	250	○	○
150	○	○	300	○	○

④ Options

Name	Option Code	Reference Page
Actuator cable length 2m	Not specified	See P.197
Actuator cable length 5m	ACS	See P.197
Actuator cable length 10m	AC10	See P.197
Actuator cable length 15m	AC15	See P.197
Brake	B	See P.197
Cable exit direction (Bottom)	CJB	See P.197
Cable exit direction (Left)	CJL	See P.197
Cable exit direction (Right)	CJR	See P.197
Cable exit direction (Top)	CJT	See P.197
Flange	FL	See P.198
Foot bracket	FT	See P.199
Tip adapter (Internal thread)	NFA	See P.201
Non-motor end specification	NM	See P.202
T-slot nut bar	NTB	See P.202

③ Cable Length

Cable Type	Cable Code	RCP6W			RCP6SW
		P3	P5	SE	
Standard	P(1m)	○	○	○	
	S(3m)	○	○	○	
	M(5m)	○	○	○	
	X06(6m)~X10(10m)	○	○	○	
Specified length	X11(11m)~X15(15m)	○	○	○	
	X16(16m)~X18(18m)	○	○	○	
	R01(1m)~R03(3m)	○	○	○	
Robot cable	R04(4m)~R05(5m)	○	○	○	
	R06(6m)~R10(10m)	○	○	○	
	R11(11m)~R15(15m)	○	○	○	
	R16(16m)~R18(18m)	○	○	○	

* Select the length of the actuator cable and the actuator/controller connection cable so that the total is 20m or less.

* Please refer to P. 267 and 283 for more information regarding the maintenance cables.

Actuator Specifications

Item	Description
Drive system	Ball screw φ10mm, rolled C10
Positioning repeatability	±0.01mm
Lost motion	0.1mm or less
Rod	φ25mm
Allowable static torque on rod tip	1.5N·m
Max. angular displacement on rod tip (*1)	±1.0 deg.
Protective structure	IP65 (IEC 60529/JIS C 0920)
Ambient operating temp. & humidity	0~40°C, 85% RH or less (Non-condensing)

(*1) This is the displacement angle of the rod tip (initial reference value) when the rod is fully retracted and the allowable static torque is applied at the rod tip.

CAD drawings can be downloaded from our website.
www.intelligentactuator.com



*1 When the rod is returning to its home position, please be careful of interference from surrounding objects, as it will travel until it reaches the M.E.
M.E: Mechanical end S.E: Stroke end
*2 The direction of width across flats varies depending on the product.

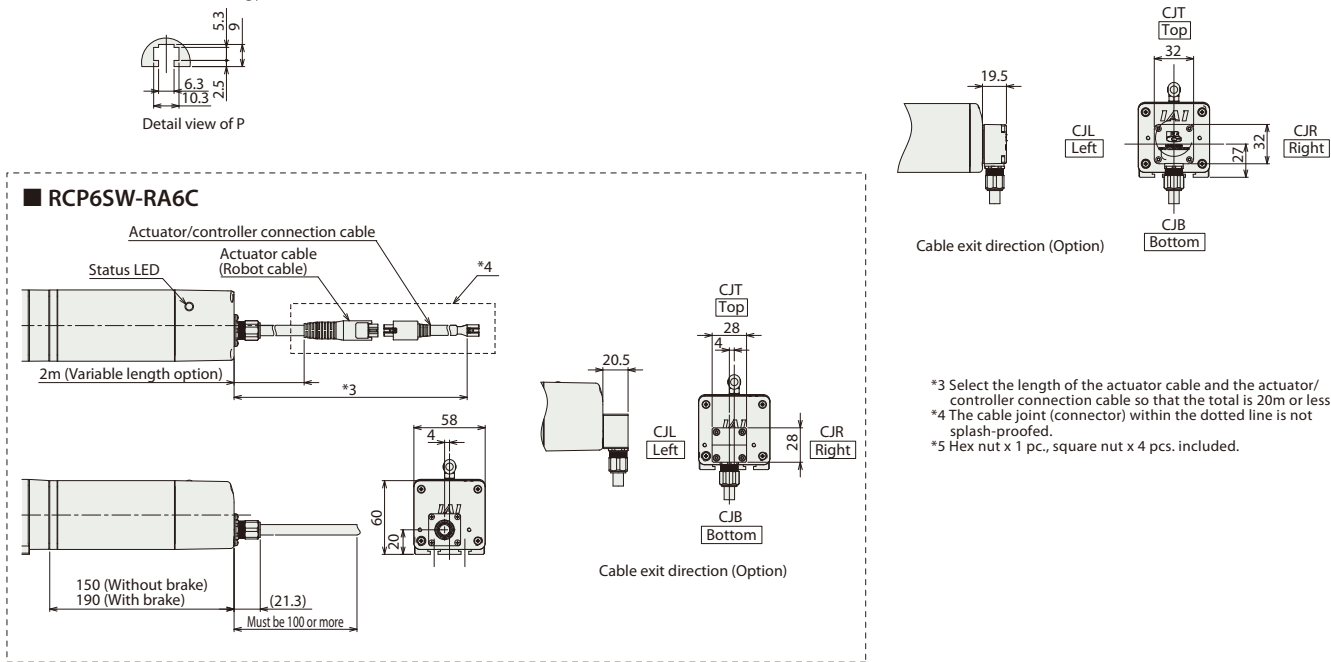
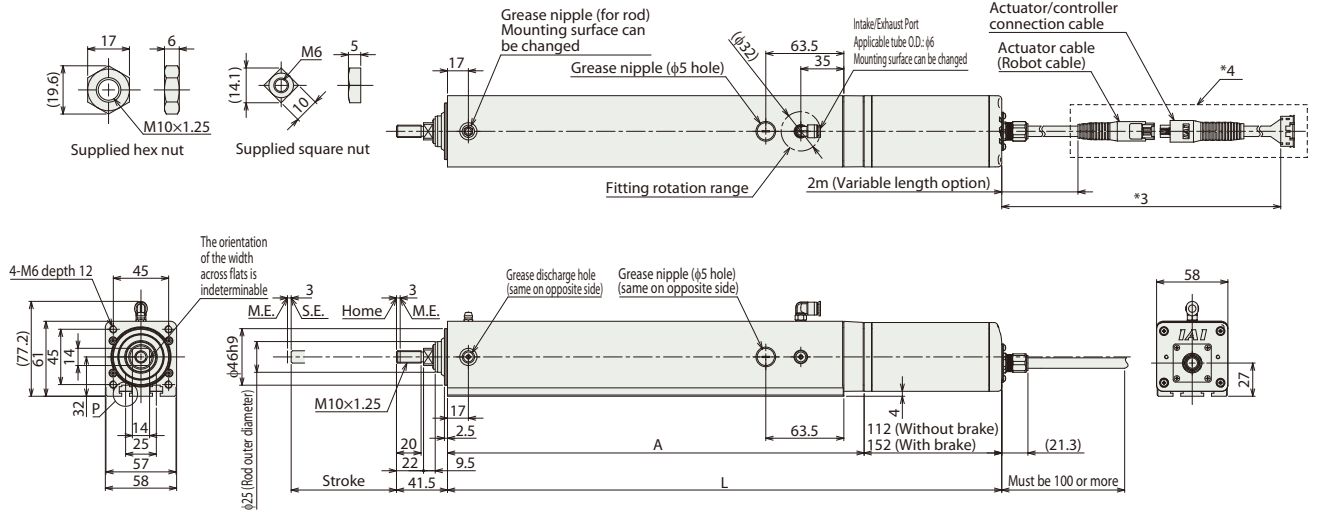

■ Dimensions and Mass by Stroke

L	Stroke	50	100	150	200	250	300
		RCP6W	w/o brake 301	w/o brake 351	w/o brake 401	w/o brake 451	w/o brake 501
A	RCP6W	w/ brake 341	w/ brake 391	w/ brake 441	w/ brake 491	w/ brake 541	w/ brake 591
	RCP6SW	w/o brake 339	w/o brake 389	w/o brake 439	w/o brake 489	w/o brake 539	w/o brake 589
Mass (kg)	RCP6W	w/ brake 379	w/ brake 429	w/ brake 479	w/ brake 529	w/ brake 579	w/ brake 629
	RCP6SW	w/o brake 189	w/o brake 239	w/o brake 289	w/o brake 339	w/o brake 389	w/o brake 439
Mass (kg)	RCP6W	w/o brake 2.5	w/o brake 2.9	w/o brake 3.3	w/o brake 3.6	w/o brake 4.0	w/o brake 4.4
	RCP6SW	w/ brake 2.8	w/ brake 3.2	w/ brake 3.6	w/ brake 3.9	w/ brake 4.3	w/ brake 4.7
Mass (kg)	RCP6W	w/o brake 2.7	w/o brake 3.1	w/o brake 3.5	w/o brake 3.8	w/o brake 4.2	w/o brake 4.6
	RCP6SW	w/ brake 2.9	w/ brake 3.3	w/ brake 3.7	w/ brake 4.0	w/ brake 4.4	w/ brake 4.8

* Please refer to P.249 and P.250 for more information on component materials.

② Applicable Controllers

The RCP6 series actuators can be operated by the controllers indicated below. Please select the type depending on your intended use. * Please refer to P.271 for more information about the built-in controller of RCP6S series.

Name	External view	Max. number of controlled axes	Input power	Control method				Maximum number of positioning points	Reference page
				Positioner	Pulse train	Program	Network * Option		
PCON-CYB/PLB/POB		1	DC24V	●	●	—	Network cannot be selected	64	Please contact IAI for more information.
PCON-CB/CGB		1		* Option	* Option	—	DeviceNet MECHATROLINK CC-Link EtherCAT EtherNet/IP CompoNet	512	See P.255
MCON-C/CG		8		This model is network-compatible only.				256	
MCON-LC/LCG		6		—	—	●	256	Please contact IAI for more information.	
MSEL-PC/PG		4	Single-phase 100 ~ 230 VAC	—	—	●	30,000	Please contact IAI for more information.	
RCM-P6PC		1	Usable within the RCP6S Gateway system.				768	See P.279	

* For the MCON controller, high-output enabled operation is only available if "high-output setting" is selected as an option. The maximum connectable axes with high-output enabled are C: 4 and LC: 3.

Foreword
Slider Type
Wide Slider Type
Rod Type
Radial Cylinder
Wide Radial Cylinder
Table Type
Cleanroom Slider
Cleanroom Wide Slider
Dust/Splash-Proof Rod
Dust/Splash-Proof Radial Cylinder
Dust/Splash-Proof Wide Radial Cylinder
Options
Reference Data
Controller

RCP6(S)W-RA7C

Dust/Splash-Proof Spec Battery-less Absolute Motor Unit Type Coupled Motor Body Width 70 mm 24v Stepper Motor

Model Specification Items	Series	Type	Encoder Type	Motor Type	Lead	Stroke	Applicable Controller/I/O Type	Cable Length	Options
	RA7C	WA	56P						
	RCP6W: Separate Controller RCP6SW: Built-in Controller	WA: Battery-less Absolute	56P: Stepper Motor 56□ Size	16 : 16mm 8 : 8mm 4 : 4mm	50:50mm 300:300mm (Every 50mm)	[RCP6W] P3 : PCON MCON MSEL P5 : RCM-P6PC [RCP6SW] SE: SIO Type	N : None P : 1m S : 3m M : 5m XC□ : Specified Length R□ : Robot Cable	Please refer to the options table below.	

* RCP6 does not include a controller. RCP6S includes a built-in controller.
* Please refer to P.19 for more information about the model specification items.

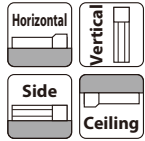

*Some limitations may apply to horizontal/side/ceiling mountings depending on the model. See page 204. Please contact IAI for more information.



- POINT Selection Notes**
- The maximum acceleration/deceleration is 1G for horizontal, and 0.5G for vertical use.
 - The actuator specifications displays the payload's maximum value, but it will vary depending on the acceleration and speed. Please refer to the "Selection Guidelines" (Tables of Payload by Speed/Acceleration) on P.232 for more details.
 - The value of the horizontal payload assumes that there is an external guide. Please be aware that the anti-rotation stopper can be damaged when an external force is applied to the rod from any direction other than the moving direction.
 - Please refer to P205 for performing push-motion operation.
 - Depending on the ambient operating temperature, duty control is necessary for the RCP6SW (built-in controller type) with lead 4/8/16. Please refer to P.247 for more information.
 - The cable joint connector is not splash-proofed, so it should be located where there is no splash.

Correlation Diagrams of Speed and Payload

If the ambient temperature is 5°C or below, the speed will be lower than when it exceeds 5°C.

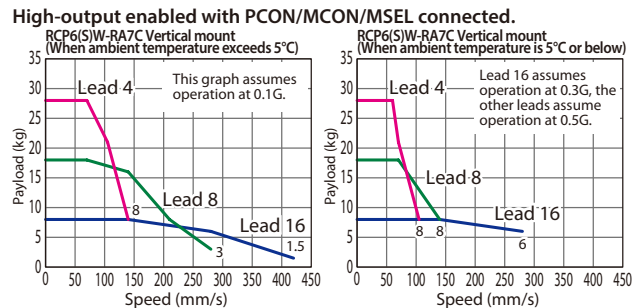
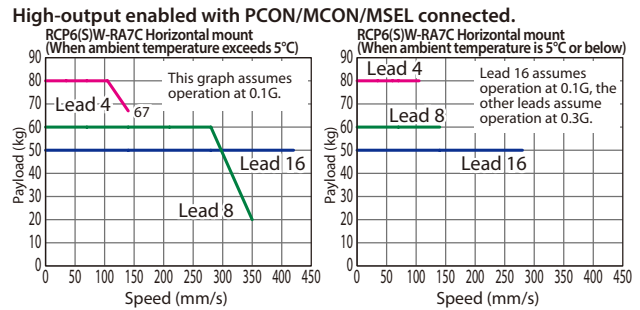

Actuator Specifications

Lead and Payload

* Push force only available during push mode w / limited speed.

Stroke and Max Speed

(Unit: mm/s)

Model Number	Lead (mm)	Max. Payload		Max. Push Force (N)*	Stroke (mm)
		Horizontal (kg)	Vertical (kg)		
RCP6(S)W-RA7C-WA-56P-16-①-②-③-④	16	50	8	273	50~300 (Every 50mm)
RCP6(S)W-RA7C-WA-56P-8-①-②-③-④	8	60	18	547	
RCP6(S)W-RA7C-WA-56P-4-①-②-③-④	4	80	28	1,094	

Lead (mm)	50~300 (Every 50mm)	
	Horizontal (mm/s)	Vertical (mm/s)
16	420 [280]	
8	350 <280> [140]	
4	140 [105]	

Legend: ① Stroke ② Applicable controllers/I/O type ③ Cable length ④ Options

Values in brackets <> are for vertical use.
Values in brackets [] are when ambient temperature is 5°C or below.

① Stroke

Stroke (mm)	RCP6W	RCP6SW	Stroke (mm)	RCP6W	RCP6SW
50	○	○	200	○	○
100	○	○	250	○	○
150	○	○	300	○	○

④ Options

Name	Option Code	Reference Page
Actuator cable length 2m	Not specified	See P.197
Actuator cable length 5m	ACS	See P.197
Actuator cable length 10m	AC10	See P.197
Actuator cable length 15m	AC15	See P.197
Brake	B	See P.197
Cable exit direction (Bottom)	CJB	See P.197
Cable exit direction (Left)	CJL	See P.197
Cable exit direction (Right)	CJR	See P.197
Cable exit direction (Top)	CJT	See P.197
Flange	FL	See P.198
Foot bracket	FT	See P.199
Tip adapter (Internal thread)	NFA	See P.201
Non-motor end specification	NM	See P.202
T-slot nut bar	NTB	See P.202

③ Cable Length

Cable Type	Cable Code	RCP6W			RCP6SW
		P3	P5	SE	
Standard	P(1m)	○	○	○	
	S(3m)	○	○	○	
	M(5m)	○	○	○	
	X06(6m)~X10(10m)	○	○	○	
Specified length	X11(11m)~X15(15m)	○	○	○	
	X16(16m)~X18(18m)	○	○	○	
	R01(1m)~R03(3m)	○	○	○	
Robot cable	R04(4m)~R05(5m)	○	○	○	
	R06(6m)~R10(10m)	○	○	○	
	R11(11m)~R15(15m)	○	○	○	
	R16(16m)~R18(18m)	○	○	○	

* Select the length of the actuator cable and the actuator/controller connection cable so that the total is 20m or less.

* Please refer to P. 267 and 283 for more information regarding the maintenance cables.

Actuator Specifications

Item	Description
Drive system	Ball screw φ12mm, rolled C10
Positioning repeatability	±0.01mm
Lost motion	0.1mm or less
Rod	φ30mm
Allowable static torque on rod tip	2.5N·m
Max. angular displacement on rod tip (*1)	±0.8 deg.
Protective structure	IP65 (IEC 60529/JIS C 0920)
Ambient operating temp. & humidity	0~40°C, 85% RH or less (Non-condensing)

(*1) This is the displacement angle of the rod tip (initial reference value) when the rod is fully retracted and the allowable static torque is applied at the rod tip.

CAD drawings can be downloaded from our website.
www.intelligentactuator.com



*1 When the rod is returning to its home position, please be careful of interference from surrounding objects, as it will travel until it reaches the M.E.
M.E: Mechanical end S.E: Stroke end
*2 The direction of width across flats varies depending on the product.

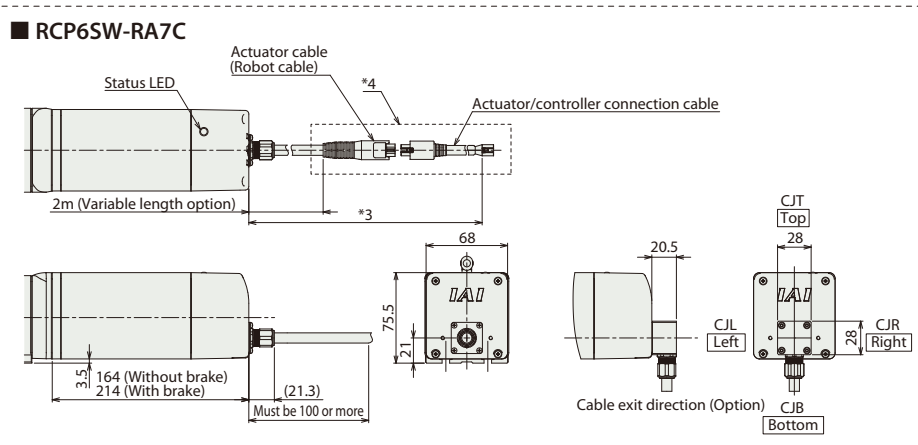
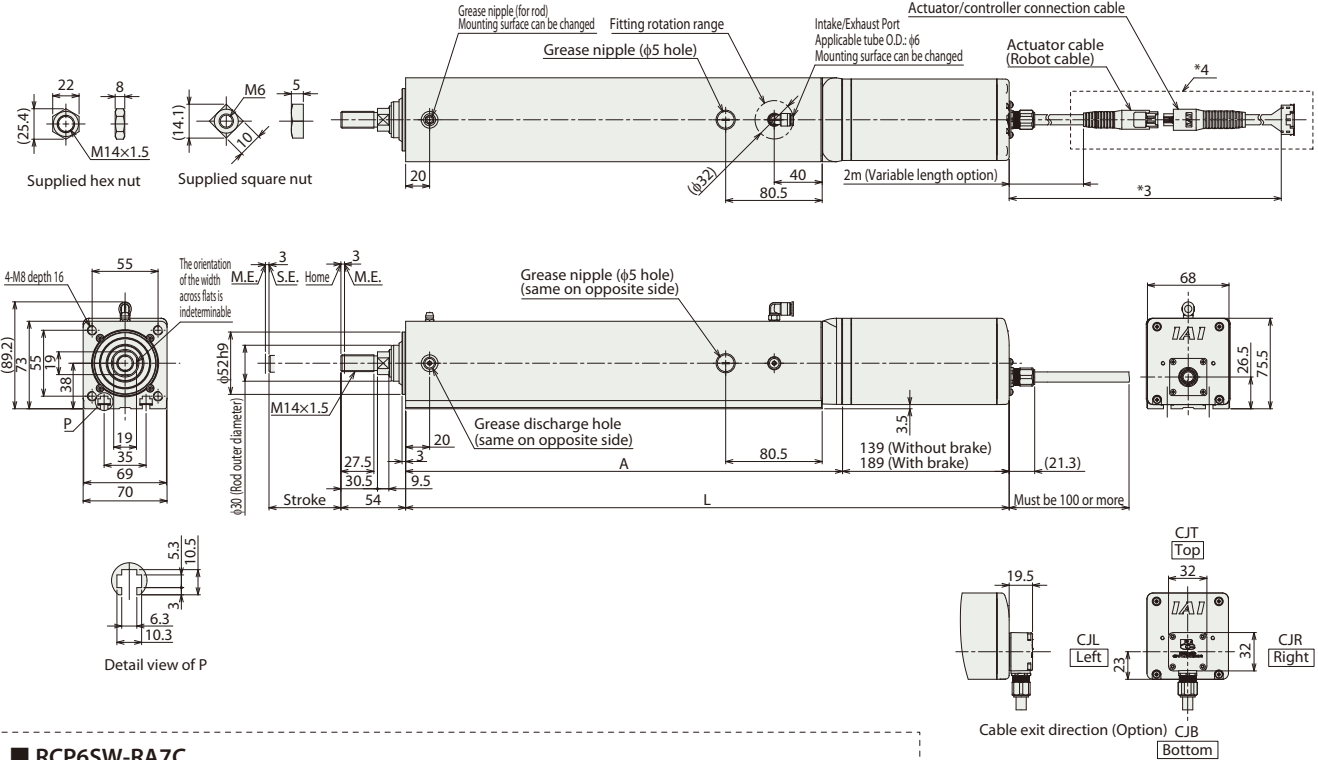

*3 Select the length of the actuator cable and the actuator/controller connection cable so that the total is 20m or less.
*4 The cable joint (connector) within the dotted line is not splash-proofed.
*5 Hex nut x 1 pc., square nut x 6 pcs. included.

■ Dimensions and Mass by Stroke

L	Stroke	50	100	150	200	250	300	
		RCP6W	w/o brake	353.5	403.5	453.5	503.5	553.5
	w/ brake	403.5	453.5	503.5	553.5	603.5	653.5	
A	RCP6SW	w/o brake	378.5	428.5	478.5	528.5	578.5	628.5
	w/ brake	428.5	478.5	528.5	578.5	628.5	678.5	
Mass (kg)	RCP6W	w/o brake	4.5	5.1	5.7	6.3	6.8	7.4
	w/ brake	5.0	5.6	6.2	6.8	7.3	7.9	
RCP6SW	w/o brake	4.7	5.3	5.9	6.5	7.0	7.6	
	w/ brake	5.1	5.7	6.3	6.9	7.4	8.0	

* Please refer to P.250 for more information on component materials.

② Applicable Controllers

The RCP6 series actuators can be operated by the controllers indicated below. Please select the type depending on your intended use. * Please refer to P.271 for more information about the built-in controller of RCP6S series.

Name	External view	Max. number of controlled axes	Input power	Control method				Maximum number of positioning points	Reference page
				Positioner	Pulse train	Program	Network * Option		
PCON-CYB/PLB/POB		1	DC24V	●	●	-	Network cannot be selected	64	Please contact IAI for more information.
PCON-CB/CGB		1		* Option	* Option	-	DeviceNet MECHATROLINK CC-Link EtherCAT EtherNet/IP CompoNet	512	(768 for network spec.) See P.255
MCON-C/CG		8		This model is network-compatible only.				256	
MCON-LC/LCG		6		-	-	●	256	Please contact IAI for more information.	
MSEL-PC/PG		4	Single-phase 100 ~ 230 VAC	-	-	●	30,000	Please contact IAI for more information.	
RCM-P6PC		1	Usable within the RCP6S Gateway system.				768	See P.279	

* For the MCON controller, high-output enabled operation is only available if "high-output setting" is selected as an option. The maximum connectable axes with high-output enabled are C: 4 and LC: 3.

Foreword
Slider Type
Wide Slider Type
Rod Type
Radial Cylinder
Wide Radial Cylinder
Table Type
Cleanroom Slider
Cleanroom Wide Slider
Dust/Splash-Proof Rod
Dust/Splash-Proof Radial Cylinder
Dust/Splash-Proof Wide Radial Cylinder
Options
Reference Data
Controller

RCP6(S)W-RA8C

Dust/Splash-Proof Spec
Battery-less Absolute
Motor Unit Type
Coupled Motor
Body Width 85 mm
24v Stepper Motor

Model Specification Items

Series	Type	Encoder Type	Motor Type	Lead	Stroke	Applicable Controller/I/O Type	Cable Length	Options
RA8C	WA	60P						
RCP6W: Separate Controller RCP6SW: Built-in Controller	WA: Battery-less Absolute	60P: Stepper Motor 60□ Size	20 :20mm 10 :10mm 5 : 5mm	50:50mm 300:300mm (Every 50mm)	[RCP6W] P4 : PCON-CFB/ CGFB [RCP6SW] SE: SIO Type	N : None P : 1m S : 3m M : 5m XC□ : Specified Length R□□ : Robot Cable	Please refer to the options table below.	

* RCP6 does not include a controller. RCP6S includes a built-in controller.
* Please refer to P.19 for more information about the model specification items.

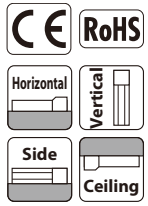

*Some limitations may apply to horizontal/side/ceiling mountings depending on the model. See page 204. Please contact IAI for more information.

- POINT Selection Notes**
- (1) The maximum acceleration/deceleration is 0.1G for lead 5 and 0.2G for lead 10/20.
 - (2) The actuator specifications displays the payload's maximum value, but it will vary depending on the acceleration and speed. Please refer to the "Selection Guidelines" (Tables of Payload by Speed/Acceleration) on P.232 for more details.
 - (3) The value of the horizontal payload assumes that there is an external guide. Please be aware that the anti-rotation stopper can be damaged when an external force is applied to the rod from any direction other than the moving direction.
 - (4) Please refer to P.205 for performing push-motion operation.
 - (5) For RCP6SW (built-in controller type), please limit the duty cycle to 70% or less.
 - (6) The service life of an actuator varies depending on the payload when using vertically. Please refer to P. 206 for more information.
 - (7) The cable joint connector is not splash-proofed, so it should be located where there is no splash.

Correlation Diagrams of Speed and Payload

If the ambient temperature is 5°C or below, the speed will be lower than when it exceeds 5°C.

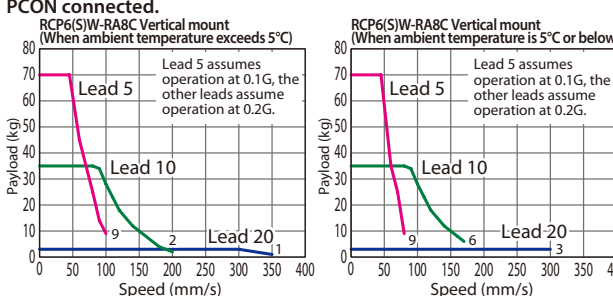
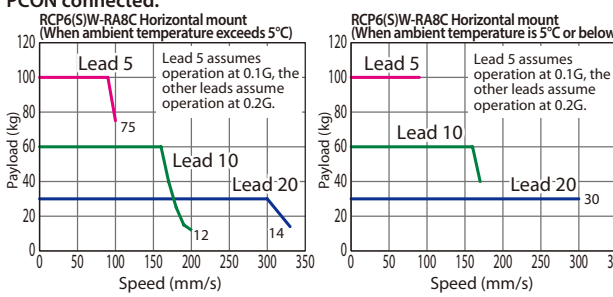

Actuator Specifications

Lead and Payload

* Push force only available during push mode w / limited speed.

Model Number	Lead (mm)	Max. Payload		Max. Push Force (N)*	Stroke (mm)
		Horizontal (kg)	Vertical (kg)		
RCP6(S)W-RA8C-WA-60P-20-①-②-③-④	20	30	3	500	50~300 (Every 50mm)
RCP6(S)W-RA8C-WA-60P-10-①-②-③-④	10	60	35	1,000	
RCP6(S)W-RA8C-WA-60P-5-①-②-③-④	5	100	70	2,000	

Legend: ① Stroke ② Applicable controllers/I/O type ③ Cable length ④ Options

Stroke and Max Speed

Lead (mm)	50~300 (Every 50mm)
20	350 <330> [300]
10	200 [170]
5	100 [80]

Values in brackets < > are for vertical use.
Values in brackets [] are when ambient temperature is 5°C or below.

① Stroke

Stroke (mm)	RCP6W	RCP6SW	Stroke (mm)	RCP6W	RCP6SW
50	○	○	200	○	○
100	○	○	250	○	○
150	○	○	300	○	○

④ Options

Name	Option Code	Reference Page
Actuator cable length 2m	Not specified	See P.197
Actuator cable length 5m	ACS	See P.197
Actuator cable length 10m	AC10	See P.197
Actuator cable length 15m	AC15	See P.197
Brake	B	See P.197
Cable exit direction (Bottom)	CJB	See P.197
Cable exit direction (Left)	CJL	See P.197
Cable exit direction (Right)	CJR	See P.197
Cable exit direction (Top)	CJT	See P.197
Flange	FL	See P.198
Foot bracket	FT	See P.199
Tip adapter (Internal thread)	NFA	See P.201
Non-motor end specification	NM	See P.202
T-slot nut bar	NTB	See P.202

③ Cable Length

Cable Type	Cable Code	RCP6W	RCP6SW
Standard	P(1m)	○	○
	S(3m)	○	○
	M(5m)	○	○
Specified length	X06 (6m) ~X10 (10m)	○	○
	X11 (11m) ~X15 (15m)	○	○
	X16 (16m) ~X18 (18m)	○	○
	R01 (1m) ~R03 (3m)	○	○
Robot cable	R04 (4m) ~R05 (5m)	○	○
	R06 (6m) ~R10 (10m)	○	○
	R11 (11m) ~R15 (15m)	○	○
	R16 (16m) ~R18 (18m)	○	○

* Select the length of the actuator cable and the actuator/controller connection cable so that the total is 20m or less.

* Please refer to P. 267 and 283 for more information regarding the maintenance cables.

Actuator Specifications

Item	Description
Drive system	Ball screw φ16mm, rolled C10
Positioning repeatability	±0.01mm
Lost motion	0.1mm or less
Rod	φ40mm
Allowable static torque on rod tip	5N·m
Max. angular displacement on rod tip (*1)	±0.8 deg.
Protective structure	IP65 (IEC 60529/JIS C 0920)
Ambient operating temp. & humidity	0~40°C, 85% RH or less (Non-condensing)

(*1) This is the displacement angle of the rod tip (initial reference value) when the rod is fully retracted and the allowable static torque is applied at the rod tip.

RCP6(S)W-RA4R

Dust/Splash-Proof Spec
Battery-less Absolute
Motor Unit Type
Side-mounted Motor
Body Width 40mm*
24v Stepper Motor

Model Specification Items	Series	Type	Encoder Type	Motor Type	Lead	Stroke	Applicable Controller/I/O Type	Cable Length	Options
	RA4R	WA	35P						
	RCP6W: Separate Controller RCP6SW: Built-in Controller	WA: Battery-less Absolute	35P: Stepper Motor 35□ Size	10 : 10mm 5 : 5mm 2.5 : 2.5mm	50:50mm 200:200mm (Every 50mm)	[RCP6W] P3 : PCON MCON MSEL P5 : RCM-P6PC [RCP6SW] SE: SIO Type	N : None P : 1m S : 3m M : 5m XC□ : Specified Length R□ : Robot Cable	Please refer to the options table below. * Please make sure to specify ML, MR or MT when ordering the side-mounted motor type.	

* RCP6 does not include a controller. RCP6S includes a built-in controller.
* Please refer to P.19 for more information about the model specification items.

* Body width does not include the width of the side-mounted motor.

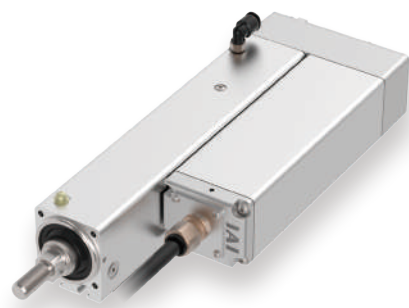
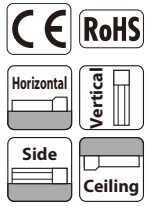

*Some limitations may apply to horizontal/side/ceiling mountings depending on the model. See page 204. Please contact IAI for more information.

The figure above is the motor side-mounted to left (ML).

	(1) The maximum acceleration/deceleration is 1G for horizontal, and 0.5G for vertical use.
	(2) The actuator specifications displays the payload's maximum value, but it will vary depending on the acceleration and speed. Please refer to the "Selection Guidelines" (Tables of Payload by Speed/Acceleration) on P.233 for more details.
	(3) The value of the horizontal payload assumes that there is an external guide. Please be aware that the anti-rotation stopper can be damaged when an external force is applied to the rod from any direction other than the moving direction.
	(4) Please refer to P205 for performing push-motion operation.
	(5) The cable joint connector is not splash-proofed, so it should be located where there is no splash.

Correlation Diagrams of Speed and Payload

If the ambient temperature is 5°C or below, the speed will be lower than when it exceeds 5°C.

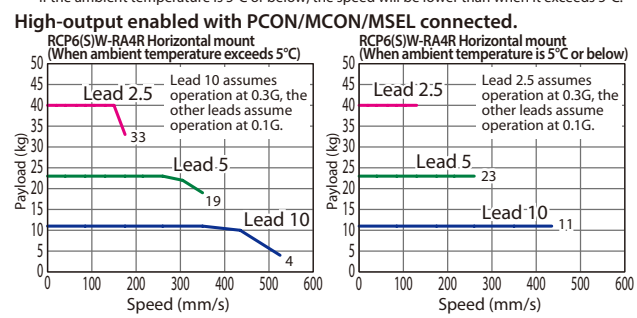

High-output enabled with PCON/MCON/MSEL connected.

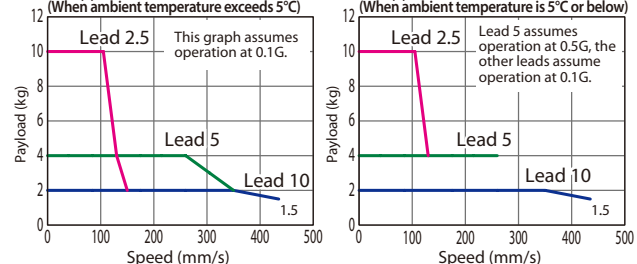

Actuator Specifications

Model Number	Lead (mm)	Max. Payload		Max. Push Force (N)*	Stroke (mm)	Stroke and Max Speed (Unit: mm/s)	
		Horizontal (kg)	Vertical (kg)			Lead (mm)	50~200 (Every 50mm)
RCP6(S)W-RA4R-WA-35P-10-①-②-③-④	10	11	2	77	50~200 (Every 50mm)	10	525 <435> [435]
RCP6(S)W-RA4R-WA-35P-5-①-②-③-④	5	23	4	155		5	350 [260]
RCP6(S)W-RA4R-WA-35P-2.5-①-②-③-④	2.5	40	10	310		2.5	175 <150> [130]

Legend: ① Stroke ② Applicable controllers/I/O type ③ Cable length ④ Options

* Push force only available during push mode w / limited speed.

Values in brackets <> are for vertical use.
Values in brackets [] are when ambient temperature is 5°C or below.

① Stroke

Stroke (mm)	RCP6W	RCP6SW	Stroke (mm)	RCP6W	RCP6SW
50	○	○	150	○	○
100	○	○	200	○	○

④ Options

Name	Option Code	Reference Page
Actuator cable length 2m	Not specified	See P.197
Actuator cable length 5m	AC5	See P.197
Actuator cable length 10m	AC10	See P.197
Actuator cable length 15m	AC15	See P.197
Brake	B	See P.197
Cable exit direction (Bottom)	CJB	See P.197
Cable exit direction (Left)	CJL	See P.197
Cable exit direction (Outside)	CJO	See P.197
Cable exit direction (Right)	CJR	See P.197
Cable exit direction (Top)	CJT	See P.197
Flange	FL	See P.198
Foot bracket	FT	See P.199
Motor side-mounted to left (standard)	ML	See P.201
Motor side-mounted to right	MR	See P.201
Motor side-mounted on top	MT	See P.201
Tip adapter (Internal thread)	NFA	See P.201
Non-motor end specification	NM	See P.202
T-slot nut bar	NTB	See P.202

* Be sure to confirm with the "Selection Notes (P.204)" when selecting options.

③ Cable Length

Cable Type	Cable Code	RCP6W			RCP6SW
		P3	P5	SE	
Standard	P(1m)	○	○	○	○
	S(3m)	○	○	○	○
	M(5m)	○	○	○	○
	X06(6m)~X10(10m)	○	○	○	○
Specified length	X11(11m)~X15(15m)	○	○	○	○
	X16(16m)~X18(18m)	○	○	○	○
	R01(1m)~R03(3m)	○	○	○	○
Robot cable	R04(4m)~R05(5m)	○	○	○	○
	R06(6m)~R10(10m)	○	○	○	○
	R11(11m)~R15(15m)	○	○	○	○
	R16(16m)~R18(18m)	○	○	○	○

* Select the length of the actuator cable and the actuator/controller connection cable so that the total is 20m or less.
* Please refer to P. 267 and 283 for more information regarding the maintenance cables.

Actuator Specifications

Item	Description
Drive system	Ball screw φ8mm, rolled C10
Positioning repeatability	±0.01mm
Lost motion	0.1mm or less
Rod	φ20mm
Allowable static torque on rod tip	1.0N·m
Max. angular displacement on rod tip (*1)	±1.0 deg.
Protective structure	IP65 (IEC 60529/JIS C 0920)
Ambient operating temp. & humidity	0~40°C, 85% RH or less (Non-condensing)

(*1) This is the displacement angle of the rod tip (initial reference value) when the rod is fully retracted and the allowable static torque is applied at the rod tip.

RCP6(S)W-RA6R

Dust/Splash-Proof Spec | Battery-less Absolute | Motor Unit Type | Side-mounted Motor | Body Width 58mm* | 24v Stepper Motor

Model Specification Items	Series	Type	Encoder Type	Motor Type	Lead	Stroke	Applicable Controller/I/O Type	Cable Length	Options
	RA6R	WA	42P						
	RCP6W: Separate Controller RCP6SW: Built-in Controller	WA: Battery-less Absolute	42P: Stepper Motor 42□ Size	12 :12mm 6 : 6mm 3 : 3mm	50:50mm 300:300mm (Every 50mm)	[RCP6W] P3 : PCON MCON MSEL P5 : RCM-P6PC [RCP6SW] SE: SIO Type	N : None P : 1m S : 3m M : 5m XC□ : Specified Length R□□ : Robot Cable	Please refer to the options table below. * Please make sure to specify ML, MR or MT when ordering the side-mounted motor type.	

* RCP6 does not include a controller. RCP6S includes a built-in controller.
* Please refer to P.19 for more information about the model specification items.



*Some limitations may apply to horizontal/side/ceiling mountings depending on the model. See page 204. Please contact IAI for more information.



The figure above is the motor side-mounted to left (ML).

	(1) The maximum acceleration/deceleration is 1G for horizontal, and 0.5G for vertical use.
	(2) The actuator specifications displays the payload's maximum value, but it will vary depending on the acceleration and speed. Please refer to the "Selection Guidelines" (Tables of Payload by Speed/Acceleration) on P.233 for more details.
	(3) The value of the horizontal payload assumes that there is an external guide. Please be aware that the anti-rotation stopper can be damaged when an external force is applied to the rod from any direction other than the moving direction.
	(4) Please refer to P205 for performing push-motion operation.
	(5) Depending on the ambient operating temperature, duty control is necessary for the RCP6SW (built-in controller type) with lead 3/6. Please refer to P.247 for more information.
	(6) The cable joint connector is not splash-proofed, so it should be located where there is no splash.

Correlation Diagrams of Speed and Payload

If the ambient temperature is 5°C or below, the speed will be lower than when it exceeds 5°C.

High-output enabled with PCON/MCON/MSEL connected.

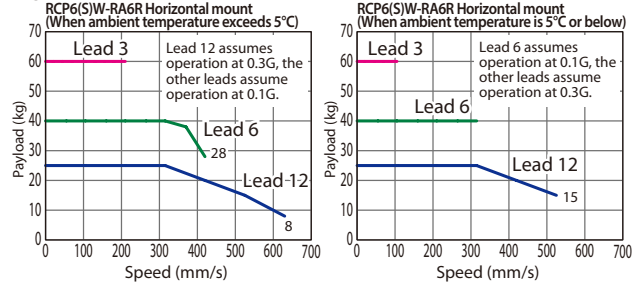

High-output enabled with PCON/MCON/MSEL connected.

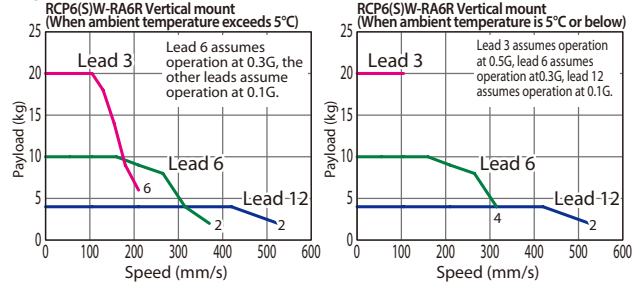

Actuator Specifications

Lead and Payload

* Push force only available during push mode w / limited speed.

Model Number	Lead (mm)	Max. Payload		Max. Push Force (N)*	Stroke (mm)
		Horizontal (kg)	Vertical (kg)		
RCP6(S)W-RA6R-WA-42P-12-①-②-③-④	12	25	4	93	50~300 (Every 50mm)
RCP6(S)W-RA6R-WA-42P-6-①-②-③-④	6	40	10	185	
RCP6(S)W-RA6R-WA-42P-3-①-②-③-④	3	60	20	370	

Legend: ① Stroke ② Applicable controllers/I/O type ③ Cable length ④ Options

Stroke and Max Speed

(Unit: mm/s)

Lead (mm)	50~300 (Every 50mm)	
	Horizontal	Vertical
12	630 <525> [525]	
6	420 <370> [315]	
3	210 [105]	

Values in brackets <> are for vertical use.
Values in brackets [] are when ambient temperature is 5°C or below.

① Stroke

Stroke (mm)	RCP6W	RCP6SW	Stroke (mm)	RCP6W	RCP6SW
50	○	○	200	○	○
100	○	○	250	○	○
150	○	○	300	○	○

④ Options

Name	Option Code	Reference Page
Actuator cable length 2m	Not specified	See P.197
Actuator cable length 5m	AC5	See P.197
Actuator cable length 10m	AC10	See P.197
Actuator cable length 15m	AC15	See P.197
Brake	B	See P.197
Cable exit direction (Bottom)	CJB	See P.197
Cable exit direction (Left)	CJL	See P.197
Cable exit direction (Outside)	CJO	See P.197
Cable exit direction (Right)	CJR	See P.197
Cable exit direction (Top)	CJT	See P.197
Flange	FL	See P.198
Foot bracket	FT	See P.199
Motor side-mounted to left (standard)	ML	See P.201
Motor side-mounted to right	MR	See P.201
Motor side-mounted on top	MT	See P.201
Tip adapter (Internal thread)	NFA	See P.201
Non-motor end specification	NM	See P.202
T-slot nut bar	NTB	See P.202

* Be sure to confirm with the "Selection Notes (P.204)" when selecting options.

③ Cable Length

Cable Type	Cable Code	RCP6W			RCP6SW
		P3	P5	SE	
Standard	P(1m)	○	○	○	○
	S(3m)	○	○	○	○
	M(5m)	○	○	○	○
	X06 (6m) ~X10 (10m)	○	○	○	○
Specified length	X11 (11m) ~X15 (15m)	○	○	○	○
	X16 (16m) ~X18 (18m)	○	○	○	○
	R01 (1m) ~R03 (3m)	○	○	○	○
Robot cable	R04 (4m) ~R05 (5m)	○	○	○	○
	R06 (6m) ~R10 (10m)	○	○	○	○
	R11 (11m) ~R15 (15m)	○	○	○	○
	R16 (16m) ~R18 (18m)	○	○	○	○

* Select the length of the actuator cable and the actuator/controller connection cable so that the total is 20m or less.

* Please refer to P. 267 and 283 for more information regarding the maintenance cables.

Actuator Specifications

Item	Description
Drive system	Ball screw φ10mm, rolled C10
Positioning repeatability	±0.01mm
Lost motion	0.1mm or less
Rod	φ25mm
Allowable static torque on rod tip	1.5N·m
Max. angular displacement on rod tip (*1)	±1.0 deg.
Protective structure	IP65 (IEC 60529/JIS C 0920)
Ambient operating temp. & humidity	0~40°C, 85% RH or less (Non-condensing)

(*1) This is the displacement angle of the rod tip (initial reference value) when the rod is fully retracted and the allowable static torque is applied at the rod tip.

RCP6(S)W-RA7R

Dust/Splash-Proof Spec | Battery-less Absolute | Motor Unit Type | Side-mounted Motor | Body Width 70 mm* | 24v Stepper Motor

Model Specification Items	Series	Type	Encoder Type	Motor Type	Lead	Stroke	Applicable Controller/I/O Type	Cable Length	Options
	RA7R	WA	56P						
	RCP6W: Separate Controller RCP6SW: Built-in Controller	WA: Battery-less Absolute	56P: Stepper Motor 56□ Size	16: 16mm 8: 8mm 4: 4mm	50: 50mm 300: 300mm (Every 50mm)	[RCP6W] P3: PCON MCON MSEL P5: RCM-P6PC [RCP6SW] SE: SIO Type	N: None P: 1m S: 3m M: 5m XC□: Specified Length R□□: Robot Cable	Please refer to the options table below. * Please make sure to specify ML, MR or MT when ordering the side-mounted motor type.	

* RCP6 does not include a controller. RCP6S includes a built-in controller.
* Please refer to P.19 for more information about the model specification items.



*Some limitations may apply to horizontal/side/ceiling mountings depending on the model. See page 204. Please contact IAI for more information.



The figure above is the motor side-mounted to left (ML).

	(1) The maximum acceleration/deceleration is 1G for horizontal, and 0.5G for vertical use.
	(2) The actuator specifications displays the payload's maximum value, but it will vary depending on the acceleration and speed. Please refer to the "Selection Guidelines" (Tables of Payload by Speed/Acceleration) on P.234 for more details.
	(3) The value of the horizontal payload assumes that there is an external guide. Please be aware that the anti-rotation stopper can be damaged when an external force is applied to the rod from any direction other than the moving direction.
	(4) Please refer to P205 for performing push-motion operation.
	(5) Depending on the ambient operating temperature, duty control is necessary for the RCP6SW (built-in controller type) with lead 4/8/16. Please refer to P.247 for more information.
	(6) The cable joint connector is not splash-proofed, so it should be located where there is no splash.

Correlation Diagrams of Speed and Payload

If the ambient temperature is 5°C or below, the speed will be lower than when it exceeds 5°C.

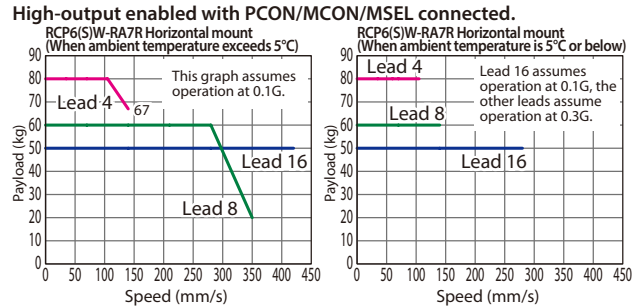

High-output enabled with PCON/MCON/MSEL connected.

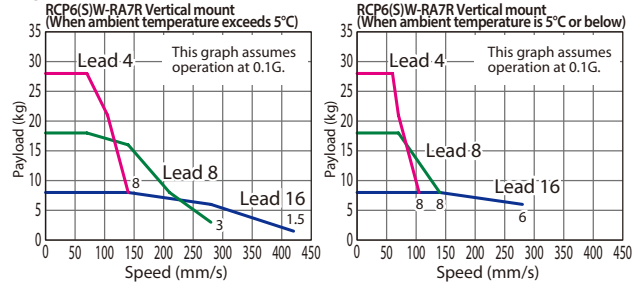

Actuator Specifications

Lead and Payload

* Push force only available during push mode w / limited speed.

Model Number	Lead (mm)	Max. Payload		Max. Push Force (N)*	Stroke (mm)
		Horizontal (kg)	Vertical (kg)		
RCP6(S)W-RA7R-WA-56P-16-①-②-③-④	16	50	8	273	50~300 (Every 50mm)
RCP6(S)W-RA7R-WA-56P-8-①-②-③-④	8	60	18	547	
RCP6(S)W-RA7R-WA-56P-4-①-②-③-④	4	80	28	1094	

Legend: ① Stroke ② Applicable controllers/I/O type ③ Cable length ④ Options

Stroke and Max Speed

(Unit: mm/s)

Lead (mm)	50~300 (Every 50mm)
16	420 [280]
8	350 <280> [140]
4	140 [105]

Values in brackets <> are for vertical use.
Values in brackets [] are when ambient temperature is 5°C or below.

① Stroke

Stroke (mm)	RCP6W	RCP6SW	Stroke (mm)	RCP6W	RCP6SW
50	○	○	200	○	○
100	○	○	250	○	○
150	○	○	300	○	○

④ Options

Name	Option Code	Reference Page
Actuator cable length 2m	Not specified	See P.197
Actuator cable length 5m	AC5	See P.197
Actuator cable length 10m	AC10	See P.197
Actuator cable length 15m	AC15	See P.197
Brake	B	See P.197
Cable exit direction (Bottom)	CJB	See P.197
Cable exit direction (Left)	CJL	See P.197
Cable exit direction (Outside)	CJO	See P.197
Cable exit direction (Right)	CJR	See P.197
Cable exit direction (Top)	CJT	See P.197
Flange	FL	See P.198
Foot bracket	FT	See P.199
Motor side-mounted to left (standard)	ML	See P.201
Motor side-mounted to right	MR	See P.201
Motor side-mounted on top	MT	See P.201
Tip adapter (Internal thread)	NFA	See P.201
Non-motor end specification	NM	See P.202
T-slot nut bar	NTB	See P.202

* Be sure to confirm with the "Selection Notes (P.204)" when selecting options.

③ Cable Length

Cable Type	Cable Code	RCP6W			RCP6SW
		P3	P5	SE	
Standard	P(1m)	○	○	○	
	S(3m)	○	○	○	
	M(5m)	○	○	○	
	X06(6m)~X10(10m)	○	○	○	
Specified length	X11(11m)~X15(15m)	○	○	○	
	X16(16m)~X18(18m)	○	○	○	
	R01(1m)~R03(3m)	○	○	○	
Robot cable	R04(4m)~R05(5m)	○	○	○	
	R06(6m)~R10(10m)	○	○	○	
	R11(11m)~R15(15m)	○	○	○	
	R16(16m)~R18(18m)	○	○	○	

* Select the length of the actuator cable and the actuator/controller connection cable so that the total is 20m or less.

* Please refer to P. 267 and 283 for more information regarding the maintenance cables.

Actuator Specifications

Item	Description
Drive system	Ball screw φ12mm, rolled C10
Positioning repeatability	±0.01mm
Lost motion	0.1mm or less
Rod	φ30mm
Allowable static torque on rod tip	2.5N·m
Max. angular displacement on rod tip (*1)	±0.8 deg.
Protective structure	IP65 (IEC 60529/JIS C 0920)
Ambient operating temp. & humidity	0~40°C, 85% RH or less (Non-condensing)

(*1) This is the displacement angle of the rod tip (initial reference value) when the rod is fully retracted and the allowable static torque is applied at the rod tip.

CAD drawings can be downloaded from our website.
www.intelligentactuator.com



*1 When the rod is returning to its home position, please be careful of interference from surrounding objects, as it will travel until it reaches the M.E.
M.E: Mechanical end S.E: Stroke end
*2 The direction of width across flats varies depending on the product.

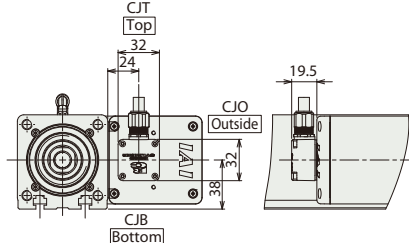
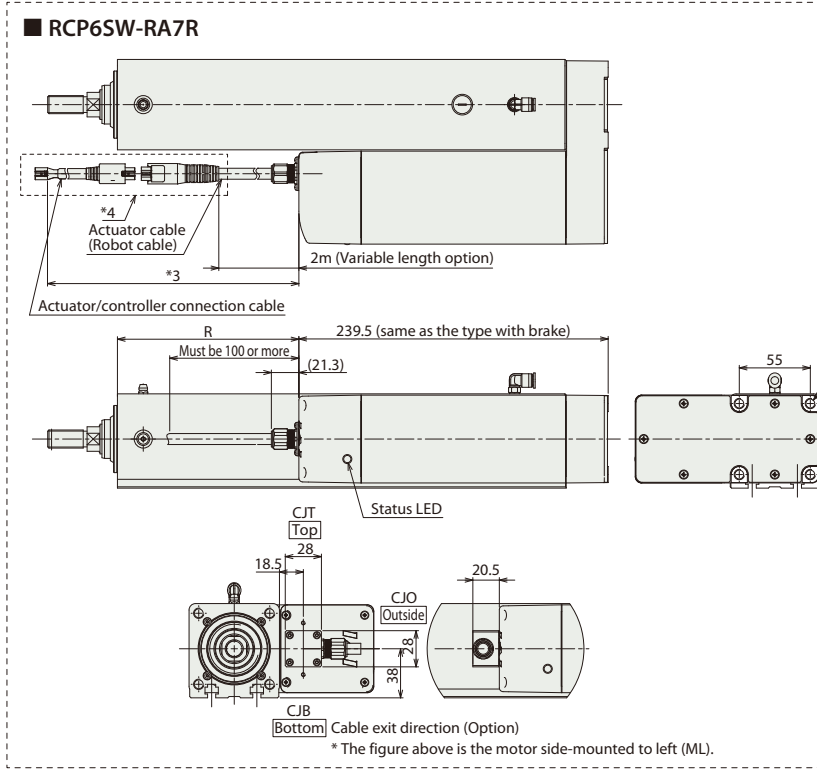
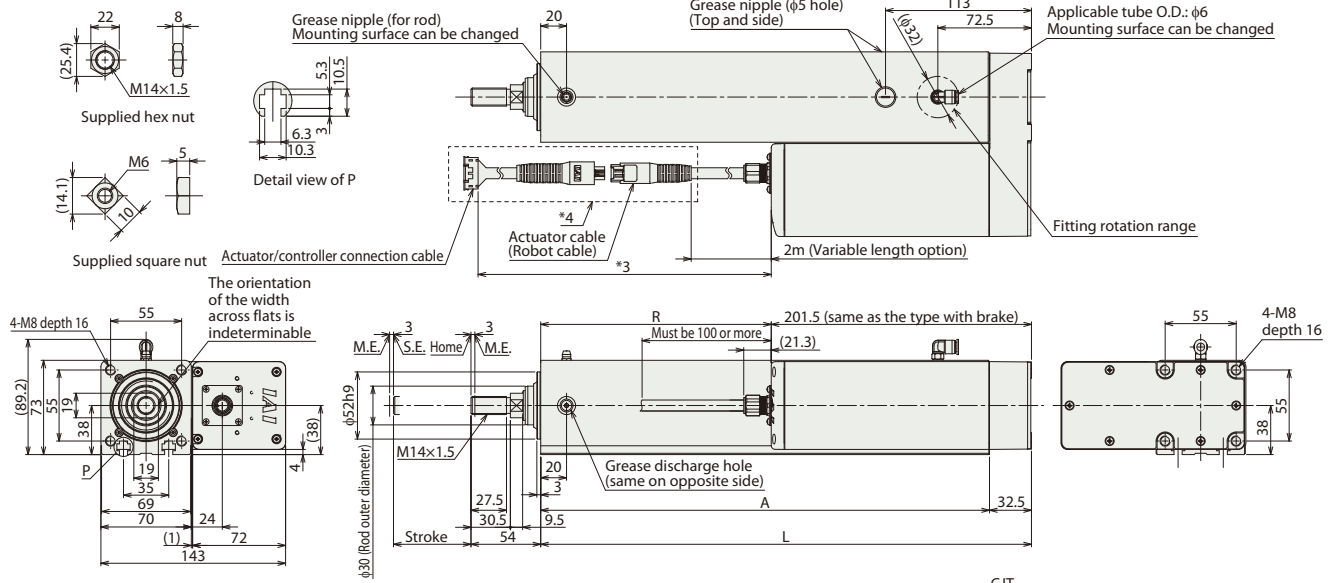

*3 Select the length of the actuator cable and the actuator/controller connection cable so that the total is 20m or less.
*4 The cable joint (connector) within the dotted line is not splash-proofed.
*5 Hex nut x 1 pc., square nut x 6 pcs. included.

■ Dimensions and Mass by Stroke

Stroke	50	100	150	200	250	300		
L	230	280	330	380	430	480		
A	197.5	247.5	297.5	347.5	397.5	447.5		
R	RCP6W	26.5	76.5	126.5	176.5	226.5	276.5	
	RCP6SW	-9.5	40.5	90.5	140.5	190.5	240.5	
Mass (kg)	RCP6W	w/o brake	5.2	5.8	6.4	7.0	7.5	8.1
	RCP6W	w/ brake	5.3	5.9	6.5	7.1	7.6	8.2
	RCP6SW	w/o brake	5.4	6.0	6.6	7.2	7.7	8.3
	RCP6SW	w/ brake	5.5	6.1	6.7	7.3	7.8	8.4

* Please refer to P.250 for more information on component materials.

* If the length for R is negative in the table below, the length of the actuator body is shorter than the motor unit.

② Applicable Controllers

The RCP6 series actuators can be operated by the controllers indicated below. Please select the type depending on your intended use. * Please refer to P.271 for more information about the built-in controller of RCP6S series.

Name	External view	Max. number of controlled axes	Input power	Control method				Maximum number of positioning points	Reference page
				Positioner	Pulse train	Program	Network * Option		
PCON-CYB/PLB/POB		1	DC24V	●	●	-	Network cannot be selected	64	Please contact IAI for more information.
PCON-CB/CGB		1		* Option	* Option	-	DeviceNet MECHATROLINK CC-Link EtherCAT EtherNet/IP PROFINET CompoNet	512 (768 for network spec.)	See P.255
MCON-C/CG		8		This model is network-compatible only.				256	Please contact IAI for more information.
MCON-LC/LCG		6		-	-	●	Note: The type of compatible networks will vary depending on the controller. Please refer to reference page for more information.	256	Please contact IAI for more information.
MSEL-PC/PG		4	Single-phase 100 ~ 230 VAC	-	-	●		30,000	Please contact IAI for more information.
RCM-P6PC		1		Usable within the RCP6S Gateway system.				768	See P.279

* For the MCON controller, high-output enabled operation is only available if "high-output setting" is selected as an option. The maximum connectable axes with high-output enabled are C: 4 and LC: 3.

Foreword
Slider Type
Wide Slider Type
Rod Type
Radial Cylinder
Wide Radial Cylinder
Table Type
Cleanroom Slider
Cleanroom Wide Slider
Dust/Splash-Proof Rod
Dust/Splash-Proof Radial Cylinder
Dust/Splash-Proof Wide Radial Cylinder
Options
Reference Data
Controller

RCP6(S)W-RA8R

Dust/Splash-Proof Spec | Battery-less Absolute | Motor Unit Type | Side-mounted Motor | Body Width 85* mm | 24v Stepper Motor

Model Specification Items	Series	RA8R	Type	WA	Encoder Type	60P	Lead	Stroke	Applicable Controller/I/O Type	Cable Length	Options
	RCP6W: Separate Controller RCP6SW: Built-in Controller		WA: Battery-less Absolute		60P: Stepper Motor 60□ Size	20 :20mm 10 :10mm 5 : 5mm	50:50mm 300:300mm (Every 50mm)	[RCP6W] P4: PCON-CFB/ CGFB [RCP6SW] SE: SIO Type	N : None P : 1m S : 3m M : 5m XC□ : Specified Length R□□ : Robot Cable		Please refer to the options table below. * Please make sure to specify ML, MR or MT when ordering the side-mounted motor type.

* RCP6 does not include a controller. RCP6S includes a built-in controller.
* Please refer to P.19 for more information about the model specification items.

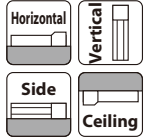

*Some limitations may apply to horizontal/side/ceiling mountings depending on the model. See page 204. Please contact IAI for more information.



The figure above is the motor side-mounted to left (ML).

- POINT Selection Notes**
- (1) The maximum acceleration/deceleration is 0.1G for lead 5 and 0.2G for lead 10/20.
 - (2) The actuator specifications displays the payload's maximum value, but it will vary depending on the acceleration and speed. Please refer to the "Selection Guidelines" (Tables of Payload by Speed/Acceleration) on P.234 for more details.
 - (3) The value of the horizontal payload assumes that there is an external guide. Please be aware that the anti-rotation stopper can be damaged when an external force is applied to the rod from any direction other than the moving direction.
 - (4) Please refer to P.205 for performing push-motion operation.
 - (5) For RCP6SW (built-in controller type), please limit the duty cycle to 70% or less.
 - (6) The service life of an actuator varies depending on the payload when using vertically. Please refer to P. 206 for more information.
 - (7) The cable joint connector is not splash-proofed, so it should be located where there is no splash.

Correlation Diagrams of Speed and Payload

If the ambient temperature is 5°C or below, the speed will be lower than when it exceeds 5°C.

PCON connected.

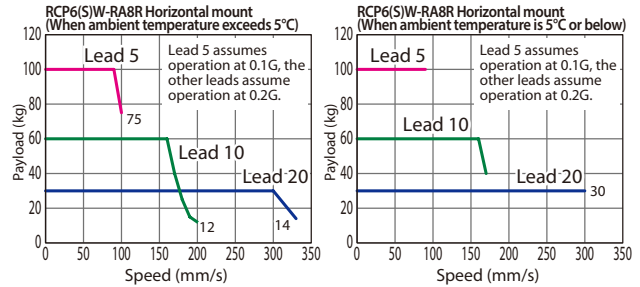

PCON connected.

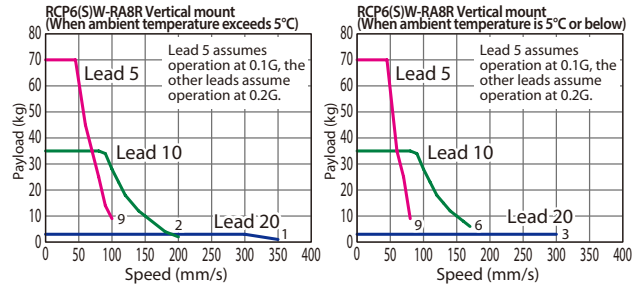

Actuator Specifications

Lead and Payload

* Push force only available during push mode w / limited speed.

Model Number	Lead (mm)	Max. Payload		Max. Push Force (N)*	Stroke (mm)
		Horizontal (kg)	Vertical (kg)		
RCP6(S)W-RA8R-WA-60P-20-①-②-③-④	20	30	3	500	50~300 (Every 50mm)
RCP6(S)W-RA8R-WA-60P-10-①-②-③-④	10	60	35	1,000	
RCP6(S)W-RA8R-WA-60P-5-①-②-③-④	5	100	70	2,000	

Legend: ① Stroke ② Applicable controllers/I/O type ③ Cable length ④ Options

Stroke and Max Speed

(Unit: mm/s)

Lead (mm)	50~300 (Every 50mm)
20	350 <330> [300]
10	200 [170]
5	100 [80]

Values in brackets < > are for vertical use.
Values in brackets [] are when ambient temperature is 5°C or below.

① Stroke

Stroke (mm)	RCP6W	RCP6SW	Stroke (mm)	RCP6W	RCP6SW
50	○	○	200	○	○
100	○	○	250	○	○
150	○	○	300	○	○

④ Options

Name	Option Code	Reference Page
Actuator cable length 2m	Not specified	See P.197
Actuator cable length 5m	ACS	See P.197
Actuator cable length 10m	AC10	See P.197
Actuator cable length 15m	AC15	See P.197
Brake	B	See P.197
Cable exit direction (Bottom)	CJB	See P.197
Cable exit direction (Left)	CJL	See P.197
Cable exit direction (Outside)	CJO	See P.197
Cable exit direction (Right)	CJR	See P.197
Cable exit direction (Top)	CJT	See P.197
Flange	FL	See P.198
Foot bracket	FT	See P.199
Motor side-mounted to left (standard)	ML	See P.201
Motor side-mounted to right	MR	See P.201
Motor side-mounted on top	MT	See P.201
Tip adapter (Internal thread)	NFA	See P.201
Non-motor end specification	NM	See P.202
T-slot nut bar	NTB	See P.202

* Be sure to confirm with the "Selection Notes (P.204)" when selecting options.

③ Cable Length

Cable Type	Cable Code	RCP6W	RCP6SW
Standard	P(1m)	○	○
	S(3m)	○	○
	M(5m)	○	○
Specified length	X06 (6m) ~X10 (10m)	○	○
	X11 (11m) ~X15 (15m)	○	○
	X16 (16m) ~X18 (18m)	○	○
	R01 (1m) ~R03 (3m)	○	○
Robot cable	R04 (4m) ~R05 (5m)	○	○
	R06 (6m) ~R10 (10m)	○	○
	R11 (11m) ~R15 (15m)	○	○
	R16 (16m) ~R18 (18m)	○	○

* Select the length of the actuator cable and the actuator/controller connection cable so that the total is 20m or less.

* Please refer to P. 267 and 283 for more information regarding the maintenance cables.

Actuator Specifications

Item	Description
Drive system	Ball screw φ16mm, rolled C10
Positioning repeatability	±0.01 mm
Lost motion	0.1 mm or less
Rod	φ40mm
Allowable static torque on rod tip	5N·m
Max. angular displacement on rod tip (*1)	±0.8 deg.
Protective structure	IP65 (IEC 60529/JIS C 0920)
Ambient operating temp. & humidity	0~40°C, 85% RH or less (Non-condensing)

(*1) This is the displacement angle of the rod tip (initial reference value) when the rod is fully retracted and the allowable static torque is applied at the rod tip.

CAD drawings can be downloaded from our website.
www.intelligentactuator.com



*1 When the rod is returning to its home position, please be careful of interference from surrounding objects, as it will travel until it reaches the M.E.
M.E: Mechanical end S.E: Stroke end
*2 The direction of width across flats varies depending on the product.

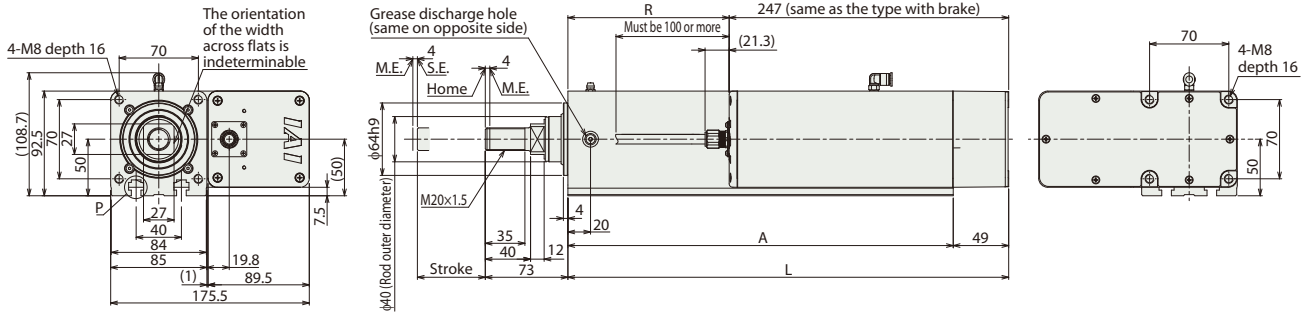
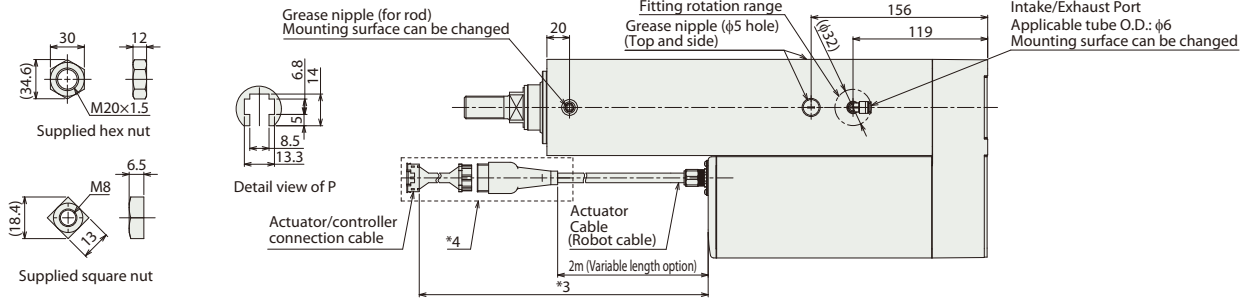

■ RCP6SW-RA8R

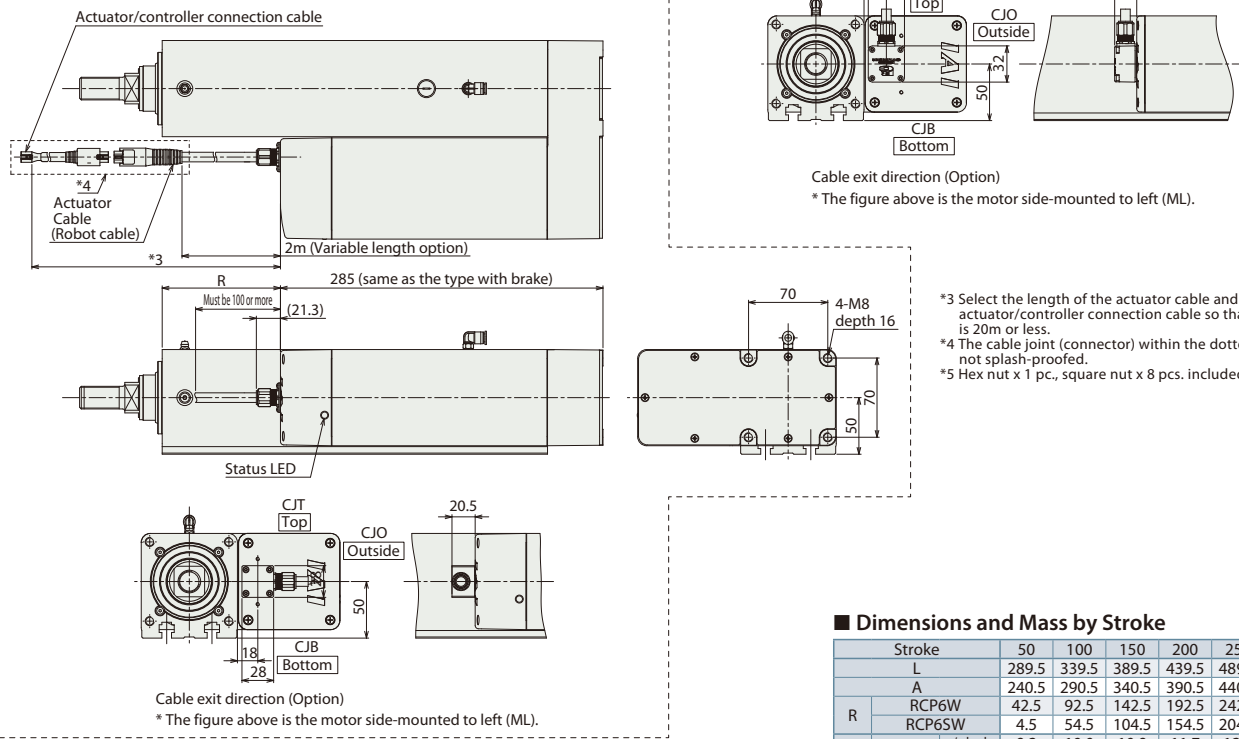

*3 Select the length of the actuator cable and the actuator/controller connection cable so that the total is 20m or less.
*4 The cable joint (connector) within the dotted line is not splash-proofed.
*5 Hex nut x 1 pc., square nut x 8 pcs. included.

* Please refer to P.250 for more information on component materials.

■ Dimensions and Mass by Stroke

Stroke		50	100	150	200	250	300
R	L	289.5	339.5	389.5	439.5	489.5	539.5
	A	240.5	290.5	340.5	390.5	440.5	490.5
	RCP6W	42.5	92.5	142.5	192.5	242.5	292.5
	RCP6SW	4.5	54.5	104.5	154.5	204.5	254.5
Mass (kg)	RCP6W w/o brake	9.2	10.0	10.9	11.7	12.6	13.4
	w/ brake	9.5	10.3	11.2	12.0	12.9	13.7
	RCP6SW w/o brake	9.5	10.3	11.2	12.0	12.9	13.7
	w/ brake	9.8	10.6	11.5	12.3	13.2	14.0

② Applicable Controllers

The RCP6 series actuators can be operated by the controllers indicated below. Please select the type depending on your intended use.* Please refer to P.271 for more information about the built-in controller of RCP6S series.

Name	External view	Max. number of controlled axes	Input power	Control method				Maximum number of positioning points	Reference page
				Positioner	Pulse train	Program	Network * Option		
PCON-CFB/CGFB		1	DC24V	● * Option	● * Option	—	DeviceNet CompoNet EtherNet/IP CC-Link MECHATROLINK EtherCAT 	512 (768 for network spec.)	See P.255

Foreword
Slider Type
Wide Slider Type
Rod Type
Radial Cylinder
Wide Radial Cylinder
Table Type
Cleanroom Slider
Cleanroom Wide Slider
Dust/Splash-Proof Rod
Dust/Splash-Proof Radial Cylinder
Dust/Splash-Proof Wide Radial Cylinder
Options
Reference Data
Controller

RCP6(S)W-RRR4C

Dust/Splash-Proof Spec
Battery-less Absolute
Motor Unit Type
Coupled Motor
Body Width 45 mm
24v Stepper Motor

Model Specification Items

Series	Type	Encoder Type	Motor Type	Lead	Stroke	Applicable Controller/I/O Type	Cable Length	Options
RCP6W: Separate Controller RCP6SW: Built-in Controller	RRA4C	WA	35P	10 : 10mm 5 : 5mm 2.5 : 2.5mm	50:50mm 400:400mm (Every 50mm)	[RCP6W] P3 : PCON MCON MSEL P5 : RCM-P6PC [RCP6SW] SE: SIO Type	N : None P : 1m S : 3m M : 5m XC□ : Specified Length R□□ : Robot Cable	Please refer to the options table below.

* RCP6 does not include a controller. RCP6S includes a built-in controller.
* Please refer to P.19 for more information about the model specification items.

Radial Load Applicable

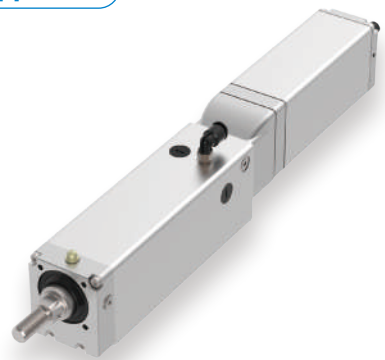
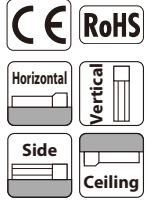

*Some limitations may apply to horizontal/side/ceiling mountings depending on the model. See page 204. Please contact IAI for more information.

- POINT Selection Notes**
- (1) The maximum acceleration/deceleration is 1G for horizontal, and 0.5G for vertical use.
 - (2) The actuator specifications displays the payload's maximum value, but it will vary depending on the acceleration and speed. Please refer to the "Selection Guidelines" (Tables of Payload by Speed/Acceleration) on P.235 for more details.
 - (3) The radial cylinder is equipped with a built-in guide. Please refer to the graphs shown on P.243 and after for the allowable load mass.
 - (4) Please refer to P.205 for performing push-motion operation.
 - (5) The cable joint connector is not splash-proofed, so it should be located where there is no splash.

Correlation Diagrams of Speed and Payload

If the ambient temperature is 5°C or below, the speed will be lower than when it exceeds 5°C.

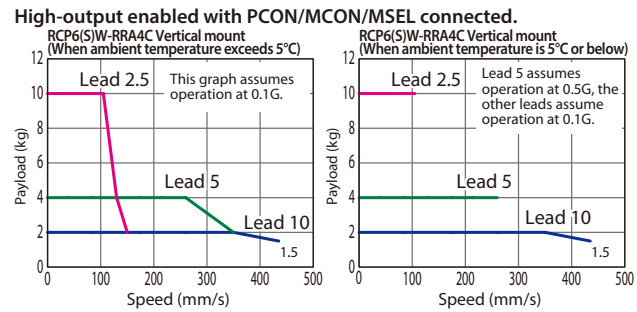
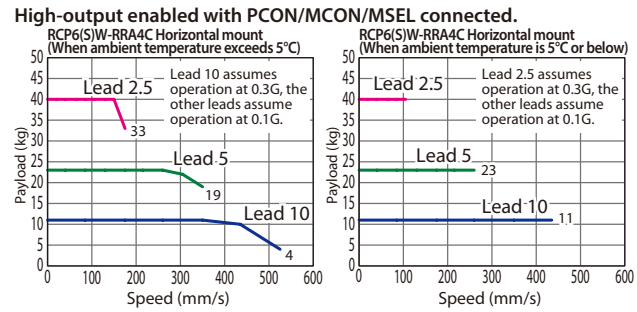

Actuator Specifications

Lead and Payload

Model Number	Lead (mm)	Max. Payload		Max. Push Force (N)**	Stroke (mm)
		Horizontal (kg)*	Vertical (kg)		
RCP6(S)W-RRR4C-WA-35P-10-①-②-③-④	10	11	2	77	50~400 (Every 50mm)
RCP6(S)W-RRR4C-WA-35P-5-①-②-③-④	5	23	4	155	
RCP6(S)W-RRR4C-WA-35P-2.5-①-②-③-④	2.5	40	10	310	

Legend: ① Stroke ② Applicable controllers/I/O type ③ Cable length ④ Options

Stroke and Max Speed (Unit: mm/s)

Lead (mm)	50~350 (Every 50mm)	400
10	525 <435> [435]	
5	350 [260]	340 [260]
2.5	175 <150> [105]	170 <150> [105]

Values in brackets <> are for vertical use.
Values in brackets [] are when ambient temperature is 5°C or below.

① Stroke

Stroke (mm)	RCP6W	RCP6SW	Stroke (mm)	RCP6W	RCP6SW
50	○	○	250	○	○
100	○	○	300	○	○
150	○	○	350	○	○
200	○	○	400	○	○

④ Options

Name	Option Code	Reference Page
Actuator cable length 2m	Not specified	See P.197
Actuator cable length 5m	AC5	See P.197
Actuator cable length 10m	AC10	See P.197
Actuator cable length 15m	AC15	See P.197
Brake	B	See P.197
Cable exit direction (Bottom)	CJB	See P.197
Cable exit direction (Left)	CJL	See P.197
Cable exit direction (Right)	CJR	See P.197
Cable exit direction (Top)	CJT	See P.197
Flange	FL	See P.198
Foot bracket	FT	See P.199
Tip adapter (Flange)	FFA	See P.197
Tip adapter (Internal thread)	NFA	See P.201
Tip adapter (Keyway)	KFA	See P.201
Non-motor end specification	NM	See P.202
T-slot nut bar	NTB	See P.202

③ Cable Length

Cable Type	Cable Code	RCP6W			RCP6SW
		P3	P5	SE	
Standard	P (1m)	○	○	○	
	S (3m)	○	○	○	
	M (5m)	○	○	○	
	X06 (6m)~ X10 (10m)	○	○	○	
Specified length	X11 (11m)~ X15 (15m)	○	○	○	
	X16 (16m)~ X18 (18m)	○	○	○	
	R01 (1m)~ R03 (3m)	○	○	○	
	R04 (4m)~ R05 (5m)	○	○	○	
Robot cable	R06 (6m)~ R10 (10m)	○	○	○	
	R11 (11m)~ R15 (15m)	○	○	○	
	R16 (16m)~ R18 (18m)	○	○	○	

* Select the length of the actuator cable and the actuator/controller connection cable so that the total is 20m or less.
* Please refer to P. 267 and 283 for more information regarding the maintenance cables.

Actuator Specifications

Item	Description
Drive system	Ball screw φ8mm, rolled C10
Positioning repeatability	±0.01mm
Lost motion	0.1mm or less
Rod	φ20mm
Rod non-rotation precision*	0 degrees
Allowable load and torque on rod tip	See P. 243
Rod tip overhang distance	100mm or less
Protective structure	IP65 (IEC 60529/JIS C 0920)
Ambient operating temp. & humidity	0~40°C, 85% RH or less (Non-condensing)

* Rod's angular displacement in rotational direction with no load applied to the rod.



- *1 When the rod is returning to its home position, please be careful of interference from surrounding objects, as it will travel until it reaches the M.E.
M.E: Mechanical end S.E: Stroke end
- *2 The direction of width across flats varies depending on the product.
- *3 When fixing the actuator using a front bracket or flange, please make sure that there is no external force applied to the main body.

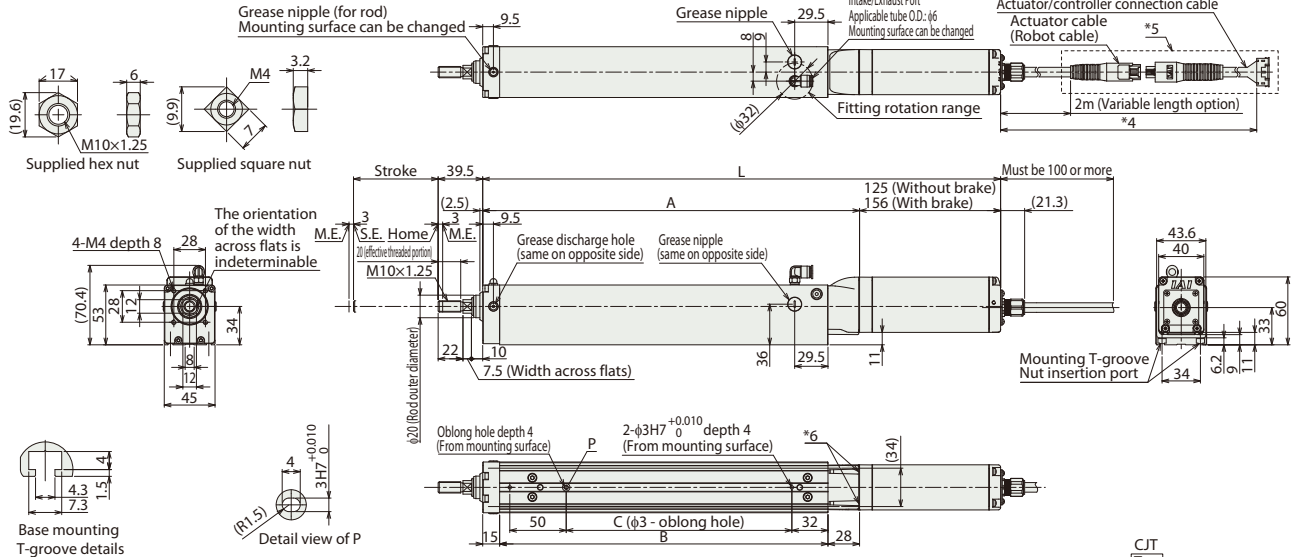

■ RCP6SW-RA4C

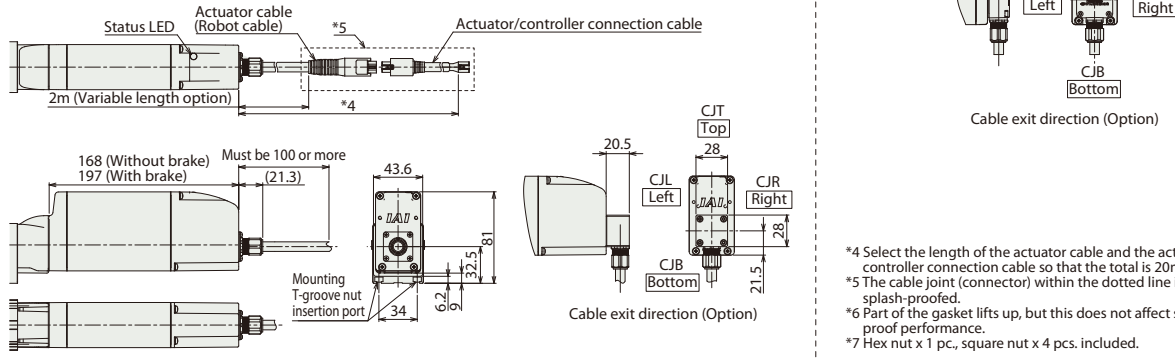

- *4 Select the length of the actuator cable and the actuator/controller connection cable so that the total is 20m or less.
- *5 The cable joint (connector) within the dotted line is not splash-proofed.
- *6 Part of the gasket lifts up, but this does not affect splash-proof performance.
- *7 Hex nut x 1 pc., square nut x 4 pcs. included.

■ Rod Deflection of RCP6(S)W-RA4C (Reference Values)

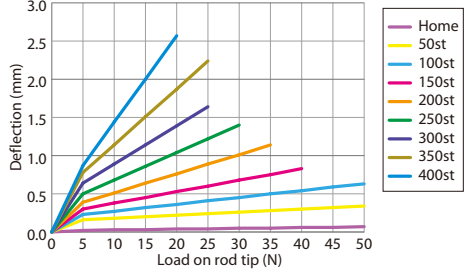

* Please refer to P.251 for more information on component materials.

■ Dimensions and Mass by Stroke

L	Stroke	50	100	150	200	250	300	350	400	
		RCP6W	309	359	409	459	509	559	609	659
RCP6SW	w/o brake	340	390	440	490	540	590	640	690	
	w/ brake	352	402	452	502	552	602	652	702	
A		184	234	284	334	384	434	484	534	
B		141	191	241	291	341	391	441	491	
C		50	100	150	200	250	300	350	400	
Allowable static load on rod tip (N)		63.4	50.7	42.1	36.0	31.3	27.6	24.6	22.2	
Allowable dynamic load on rod tip (5,000km life) (N)		28.9	22.2	17.9	14.8	12.6	10.8	9.4	8.2	
Allowable static torque on rod tip (N·m)		17.9	15.5	13.4	11.6	10.2	9.0	8.0	7.1	
Allowable dynamic torque on rod tip (N·m)		6.4	5.1	4.3	3.7	3.2	2.9	2.6	2.3	
Mass (kg)	RCP6W	w/o brake	1.5	1.7	1.9	2.1	2.3	2.5	2.7	2.9
		w/ brake	1.6	1.8	2.0	2.2	2.4	2.6	2.8	3.0
	RCP6SW	w/o brake	1.7	1.9	2.1	2.3	2.5	2.7	2.9	3.1
		w/ brake	1.8	2.0	2.2	2.4	2.6	2.8	3.0	3.2

② Applicable Controllers

The RCP6 series actuators can be operated by the controllers indicated below. Please select the type depending on your intended use. * Please refer to P.271 for more information about the built-in controller of RCP6S series.

Name	External view	Max. number of controlled axes	Input power	Control method				Maximum number of positioning points	Reference page
				Positioner	Pulse train	Program	Network * Option		
PCON-CYB/PLB/POB		1	DC24V	●	●	—	Network cannot be selected	64	Please contact IAI for more information.
PCON-CB/CGB		1		* Option	* Option	—	DeviceNet MECHATROLINK EtherCAT EtherNet/IP	512 (768 for network spec.)	See P.255
MCON-C/CG		8		This model is network-compatible only.				256	Please contact IAI for more information.
MCON-LC/LCG		6		—	—	●	CompoNet SSCNET III/H	256	Please contact IAI for more information.
MSEL-PC/PG		4	Single-phase 100 ~ 230 VAC	—	—	●	Note: The type of compatible networks will vary depending on the controller. Please refer to reference page for more information.	30,000	Please contact IAI for more information.
RCM-P6PC		1	Usable within the RCP6S Gateway system.				768	See P.279	

* For the MCON controller, high-output enabled operation is only available if "high-output setting" is selected as an option. The maximum connectable axes with high-output enabled are C: 4 and LC: 3.

Foreword
Slider Type
Wide Slider Type
Rod Type
Radial Cylinder
Wide Radial Cylinder
Table Type
Cleanroom Slider
Cleanroom Wide Slider
Dust/Splash-Proof Rod
Dust/Splash-Proof Radial Cylinder
Dust/Splash-Proof Wide Radial Cylinder
Options
Reference Data
Controller

RCP6(S)W-RRRA6C

Dust/Splash-Proof Spec
Battery-less Absolute
Motor Unit Type
Coupled Motor
Body Width 65 mm
24v Stepper Motor

Model Specification Items	Series	Type	Encoder Type	Motor Type	Lead	Stroke	Applicable Controller/I/O Type	Cable Length	Options
	RCP6W: Separate Controller RCP6SW: Built-in Controller	WA: Battery-less Absolute	42P: Stepper Motor 42□ Size	12 : 12mm 6 : 6mm 3 : 3mm	50:50mm 400:400mm (Every 50mm)	[RCP6W] P3 : PCON MCON MSEL P5 : RCM-P6PC [RCP6SW] SE: SIO Type	N : None P : 1m S : 3m M : 5m XC□ : Specified Length R□ : Robot Cable	Please refer to the options table below.	

* RCP6 does not include a controller. RCP6S includes a built-in controller.
* Please refer to P.19 for more information about the model specification items.

Radial Load Applicable

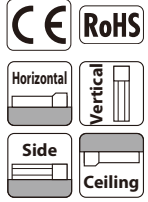

*Some limitations may apply to horizontal/side/ceiling mountings depending on the model. See page 204. Please contact IAI for more information.

- POINT Selection Notes**
- (1) The maximum acceleration/deceleration is 1G for horizontal, and 0.5G for vertical use.
 - (2) The actuator specifications displays the payload's maximum value, but it will vary depending on the acceleration and speed. Please refer to the "Selection Guidelines" (Tables of Payload by Speed/Acceleration) on P.235 for more details.
 - (3) The radial cylinder is equipped with a built-in guide. Please refer to the graphs shown on P.243 and after for the allowable load mass.
 - (4) Please refer to P.205 for performing push-motion operation.
 - (5) Depending on the ambient operating temperature, duty control is necessary for the RCP6SW (built-in controller type) with lead 3/6. Please refer to P.247 for more information.
 - (6) The cable joint connector is not splash-proofed, so it should be located where there is no splash.

Correlation Diagrams of Speed and Payload

If the ambient temperature is 5°C or below, the speed will be lower than when it exceeds 5°C.

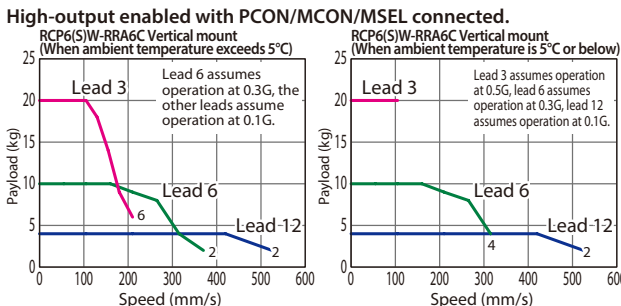
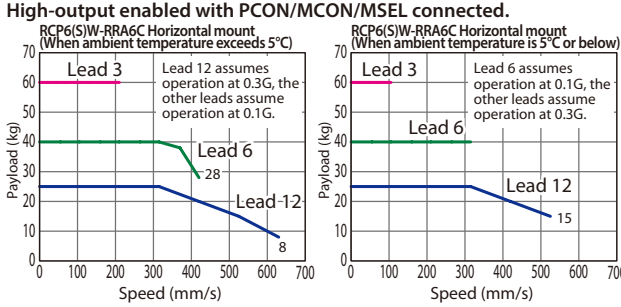

Actuator Specifications

Lead and Payload

Model Number	Lead (mm)	Max. Payload		Max. Push Force (N)**	Stroke (mm)
		Horizontal (kg)*	Vertical (kg)		
RCP6(S)W-RRRA6C-WA-42P-12-①-②-③-④	12	25	4	93	50~400 (Every 50mm)
RCP6(S)W-RRRA6C-WA-42P-6-①-②-③-④	6	40	10	185	
RCP6(S)W-RRRA6C-WA-42P-3-①-②-③-④	3	60	20	370	

Legend: ① Stroke ② Applicable controllers/I/O type ③ Cable length ④ Options

Stroke and Max Speed

Lead (mm)	50~400 (Every 50mm)
12	630 <525> [525]
6	420 <370> [315]
3	210 [105]

Values in brackets <> are for vertical use.
Values in brackets [] are when ambient temperature is 5°C or below.

① Stroke

Stroke (mm)	RCP6W	RCP6SW	Stroke (mm)	RCP6W	RCP6SW
50	○	○	250	○	○
100	○	○	300	○	○
150	○	○	350	○	○
200	○	○	400	○	○

④ Options

Name	Option Code	Reference Page
Actuator cable length 2m	Not specified	See P.197
Actuator cable length 5m	AC5	See P.197
Actuator cable length 10m	AC10	See P.197
Actuator cable length 15m	AC15	See P.197
Brake	B	See P.197
Cable exit direction (Bottom)	CJB	See P.197
Cable exit direction (Left)	CJL	See P.197
Cable exit direction (Right)	CJR	See P.197
Cable exit direction (Top)	CJT	See P.197
Flange	FL	See P.198
Foot bracket	FT	See P.199
Tip adapter (Flange)	FFA	See P.197
Tip adapter (Internal thread)	NFA	See P.201
Tip adapter (Keyway)	KFA	See P.201
Non-motor end specification	NM	See P.202
T-slot nut bar	NTB	See P.202

③ Cable Length

Cable Type	Cable Code	RCP6W			RCP6SW
		P3	P5	SE	
Standard	P (1m)	○	○	○	
	S (3m)	○	○	○	
	M (5m)	○	○	○	
	X06 (6m) ~ X10 (10m)	○	○	○	
Specified length	X11 (11m) ~ X15 (15m)	○	○	○	
	X16 (16m) ~ X18 (18m)	○	○	○	
	R01 (1m) ~ R03 (3m)	○	○	○	
	R04 (4m) ~ R05 (5m)	○	○	○	
Robot cable	R06 (6m) ~ R10 (10m)	○	○	○	
	R11 (11m) ~ R15 (15m)	○	○	○	
	R16 (16m) ~ R18 (18m)	○	○	○	

* Select the length of the actuator cable and the actuator/controller connection cable so that the total is 20m or less.
* Please refer to P. 267 and 283 for more information regarding the maintenance cables.

Actuator Specifications

Item	Description
Drive system	Ball screw φ10mm, rolled C10
Positioning repeatability	±0.01mm
Lost motion	0.1mm or less
Rod	φ25mm
Rod non-rotation precision*	0 degrees
Allowable load and torque on rod tip	See P. 243
Rod tip overhang distance	100mm or less
Protective structure	IP65 (IEC 60529/JIS C 0920)
Ambient operating temp. & humidity	0~40°C, 85% RH or less (Non-condensing)

* Rod's angular displacement in rotational direction with no load applied to the rod.

CAD drawings can be downloaded from our website.
www.intelligentactuator.com



- *1 When the rod is returning to its home position, please be careful of interference from surrounding objects, as it will travel until it reaches the M.E.
- M.E: Mechanical end S.E: Stroke end
- *2 The direction of width across flats varies depending on the product.
- *3 When fixing the actuator using a front bracket or flange, please make sure that there is no external force applied to the main body.

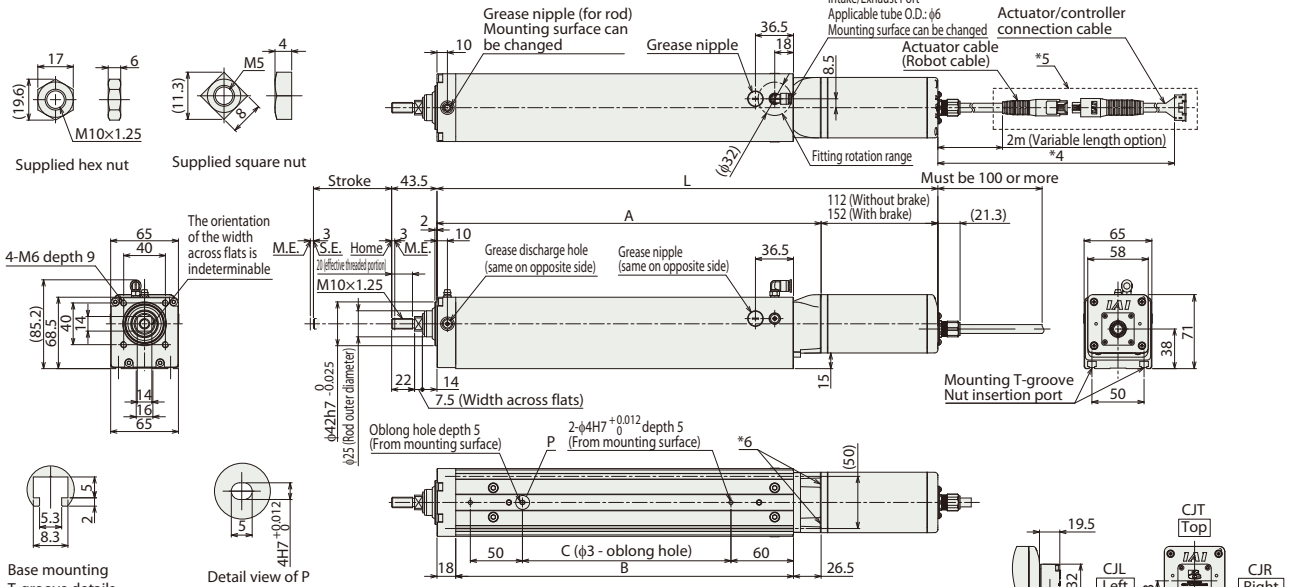

RCP6SW-RRA6C

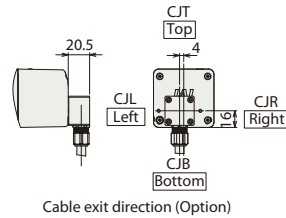
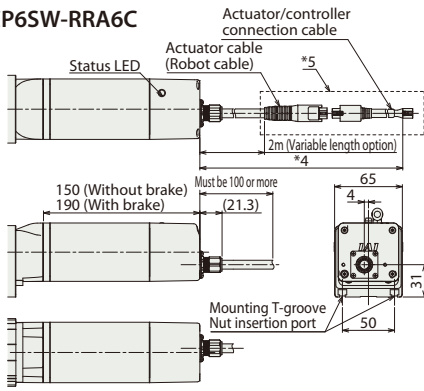

- *4 Select the length of the actuator cable and the actuator/controller connection cable so that the total is 20m or less.
- *5 The cable joint (connector) within the dotted line is not splash-proof.
- *6 Part of the gasket lifts up, but this does not affect splash-proof performance.
- *7 Hex nut x 1 pc., square nut x 4 pcs. included.

Rod Deflection of RCP6(S)W-RRA6C (Reference Values)

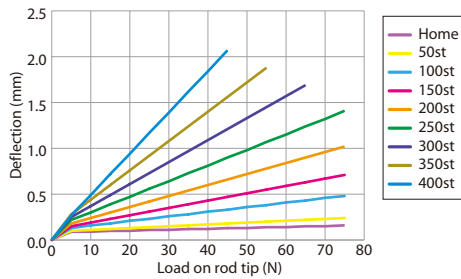

* Please refer to P.251 for more information on component materials.

Dimensions and Mass by Stroke

L	Stroke	Stroke								
		50	100	150	200	250	300	350	400	
RCP6W	w/o brake	330.5	380.5	430.5	480.5	530.5	580.5	630.5	680.5	
	w/ brake	370.5	420.5	470.5	520.5	570.5	620.5	670.5	720.5	
RCP6SW	w/o brake	368.5	418.5	468.5	518.5	568.5	618.5	668.5	718.5	
	w/ brake	408.5	458.5	508.5	558.5	608.5	658.5	708.5	758.5	
A		218.5	268.5	318.5	368.5	418.5	468.5	518.5	568.5	
B		174	224	274	324	374	424	474	524	
C		50	100	150	200	250	300	350	400	
Allowable static load on rod tip (N)		144	117	99	85.4	75	66.7	59.9	54.3	
Allowable dynamic load on rod tip (5,000km life) (N)		58.1	46.4	38.3	32.4	27.9	24.4	21.5	19.2	
Allowable static torque on rod tip (N-m)		38.8	34.0	29.7	26.2	23.2	20.8	18.7	16.8	
Allowable dynamic torque on rod tip (N-m)		14.5	11.8	10.0	8.7	7.6	6.8	6.2	5.6	
Mass (kg)	RCP6W	w/o brake	2.8	3.1	3.5	3.9	4.2	4.6	4.9	5.3
		w/ brake	3.0	3.3	3.7	4.1	4.4	4.8	5.1	5.5
	RCP6SW	w/o brake	2.9	3.2	3.6	4.0	4.3	4.7	5.0	5.4
		w/ brake	3.2	3.5	3.9	4.3	4.6	5.0	5.3	5.7

② Applicable Controllers

The RCP6 series actuators can be operated by the controllers indicated below. Please select the type depending on your intended use. * Please refer to P.271 for more information about the built-in controller of RCP6S series.

Name	External view	Max. number of controlled axes	Input power	Control method				Maximum number of positioning points	Reference page
				Positioner	Pulse train	Program	Network * Option		
PCON-CYB/PLB/POB		1	DC24V	●	●	-	Network cannot be selected	64	Please contact IAI for more information.
PCON-CB/CGB		1		* Option	* Option	-	DeviceNet MECHATROLINK CC-Link EtherCAT EtherNet/IP CANopen CompoNet	512 (768 for network spec.)	See P.255
MCON-C/CG		8		This model is network-compatible only.				256	Please contact IAI for more information.
MCON-LC/LCG		6		-	-	●	Note: The type of compatible networks will vary depending on the controller. Please refer to reference page for more information.	256	Please contact IAI for more information.
MSEL-PC/PG		4	Single-phase 100 ~ 230 VAC	-	-	●		30,000	Please contact IAI for more information.
RCM-P6PC		1		Usable within the RCP6S Gateway system.				768	See P.279

* For the MCON controller, high-output enabled operation is only available if "high-output setting" is selected as an option. The maximum connectable axes with high-output enabled are C: 4 and LC: 3.

Foreword
Slider Type
Wide Slider Type
Rod Type
Radial Cylinder
Wide Radial Cylinder
Table Type
Cleanroom Slider
Cleanroom Wide Slider
Dust/Splash-Proof Rod
Dust/Splash-Proof Radial Cylinder
Dust/Splash-Proof Wide Radial Cylinder
Options
Reference Data
Controller

RCP6(S)W-RRR7C

Dust/Splash-Proof Spec
Battery-less Absolute
Motor Unit Type
Coupled Motor
Body Width 78 mm
24v Stepper Motor

Model Specification Items	Series	Type	Encoder Type	Motor Type	Lead	Stroke	Applicable Controller/I/O Type	Cable Length	Options
	RCP6W: Separate Controller RCP6SW: Built-in Controller	WA: Battery-less Absolute	56P: Stepper Motor 56□ Size	16: 16mm 8: 8mm 4: 4mm	50: 50mm 500: 500mm (Every 50mm)	RCP6W1 P3: PCON MCON MSEL P5: RCM-P6PC RCP6SW1 SE: SIO Type	N: None P: 1m S: 3m M: 5m XC□: Specified Length R□: Robot Cable	Please refer to the options table below.	

* RCP6 does not include a controller. RCP6S includes a built-in controller.
* Please refer to P.19 for more information about the model specification items.

Radial Load Applicable

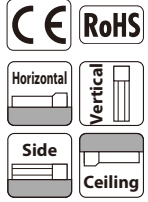

*Some limitations may apply to horizontal/side/ceiling mountings depending on the model. See page 204. Please contact IAI for more information.

- POINT Selection Notes**
- (1) The maximum acceleration/deceleration is 1G for horizontal, and 0.5G for vertical use.
 - (2) The actuator specifications displays the payload's maximum value, but it will vary depending on the acceleration and speed. Please refer to the "Selection Guidelines" (Tables of Payload by Speed/Acceleration) on P.236 for more details.
 - (3) The radial cylinder is equipped with a built-in guide. Please refer to the graphs shown on P.243 and after for the allowable load mass.
 - (4) Please refer to P.205 for performing push-motion operation.
 - (5) Depending on the ambient operating temperature, duty control is necessary for the RCP6SW (built-in controller type) with lead 4/8/16. Please refer to P.247 for more information.
 - (6) The cable joint connector is not splash-proofed, so it should be located where there is no splash.

Correlation Diagrams of Speed and Payload

If the ambient temperature is 5°C or below, the speed will be lower than when it exceeds 5°C.

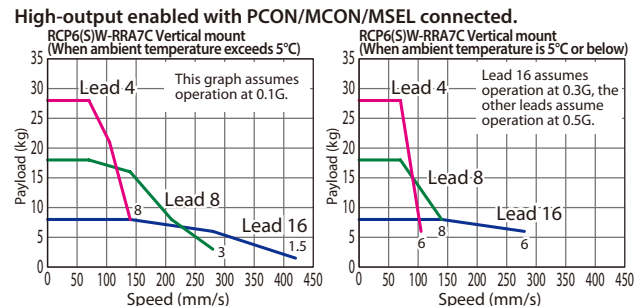
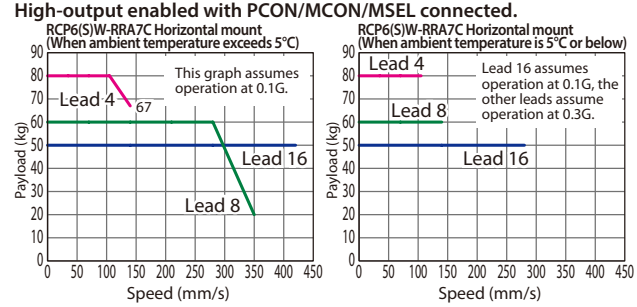

Actuator Specifications

Model Number	Lead (mm)	Max. Payload		Max. Push Force (N)**	Stroke (mm)	Stroke and Max Speed (Unit: mm/s)	
		Horizontal (kg)*	Vertical (kg)			Lead (mm)	50~500 (Every 50mm)
RCP6(S)W-RRR7C-WA-56P-16-①-②-③-④	16	50	8	273	50~500 (Every 50mm)	16	420 [280]
RCP6(S)W-RRR7C-WA-56P-8-①-②-③-④	8	60	18	547		8	350 <280> [140]
RCP6(S)W-RRR7C-WA-56P-4-①-②-③-④	4	80	28	1,094		4	140 [105]

Legend: ① Stroke ② Applicable controllers/I/O type ③ Cable length ④ Options

* Horizontal external guide rail required for horizontal payload. ** Push force only available during push mode w / limited speed.

Values in brackets <> are for vertical use. Values in brackets [] are when ambient temperature is 5°C or below.

① Stroke

Stroke (mm)	RCP6W	RCP6SW	Stroke (mm)	RCP6W	RCP6SW
50	○	○	300	○	○
100	○	○	350	○	○
150	○	○	400	○	○
200	○	○	450	○	○
250	○	○	500	○	○

④ Options

Name	Option Code	Reference Page
Actuator cable length 2m	Not specified	See P.197
Actuator cable length 5m	AC5	See P.197
Actuator cable length 10m	AC10	See P.197
Actuator cable length 15m	AC15	See P.197
Brake	B	See P.197
Cable exit direction (Bottom)	CJB	See P.197
Cable exit direction (Left)	CJL	See P.197
Cable exit direction (Right)	CJR	See P.197
Cable exit direction (Top)	CJT	See P.197
Flange	FL	See P.198
Foot bracket	FT	See P.199
Tip adapter (Flange)	FFA	See P.197
Tip adapter (Internal thread)	NFA	See P.201
Tip adapter (Keyway)	KFA	See P.201
Non-motor end specification	NM	See P.202
T-slot nut bar	NTB	See P.202

③ Cable Length

Cable Type	Cable Code	RCP6W			RCP6SW
		P3	P5	SE	
Standard	P (1m)	○	○	○	
	S (3m)	○	○	○	
	M (5m)	○	○	○	
	X06 (6m)~ X10 (10m)	○	○	○	
Specified length	X11 (11m)~ X15 (15m)	○	○	○	
	X16 (16m)~ X18 (18m)	○	○	○	
	R01 (1m)~ R03 (3m)	○	○	○	
	R04 (4m)~ R05 (5m)	○	○	○	
Robot cable	R06 (6m)~ R10 (10m)	○	○	○	
	R11 (11m)~ R15 (15m)	○	○	○	
	R16 (16m)~ R18 (18m)	○	○	○	

* Select the length of the actuator cable and the actuator/controller connection cable so that the total is 20m or less.
* Please refer to P. 267 and 283 for more information regarding the maintenance cables.

Actuator Specifications

Item	Description
Drive system	Ball screw φ12mm, rolled C10
Positioning repeatability	±0.01mm
Lost motion	0.1mm or less
Rod	φ30mm
Rod non-rotation precision*	0 degrees
Allowable load and torque on rod tip	See P. 243
Rod tip overhang distance	150mm or less
Protective structure	IP65 (IEC 60529/JIS C 0920)
Ambient operating temp. & humidity	0~40°C, 85% RH or less (Non-condensing)

* Rod's angular displacement in rotational direction with no load applied to the rod.

CAD drawings can be downloaded from our website.
www.intelligentactuator.com



- *1 When the rod is returning to its home position, please be careful of interference from surrounding objects, as it will travel until it reaches the M.E.
M.E: Mechanical end S.E: Stroke end
- *2 The direction of width across flats varies depending on the product.
- *3 When fixing the actuator using a front bracket or flange, please make sure that there is no external force applied to the main body.

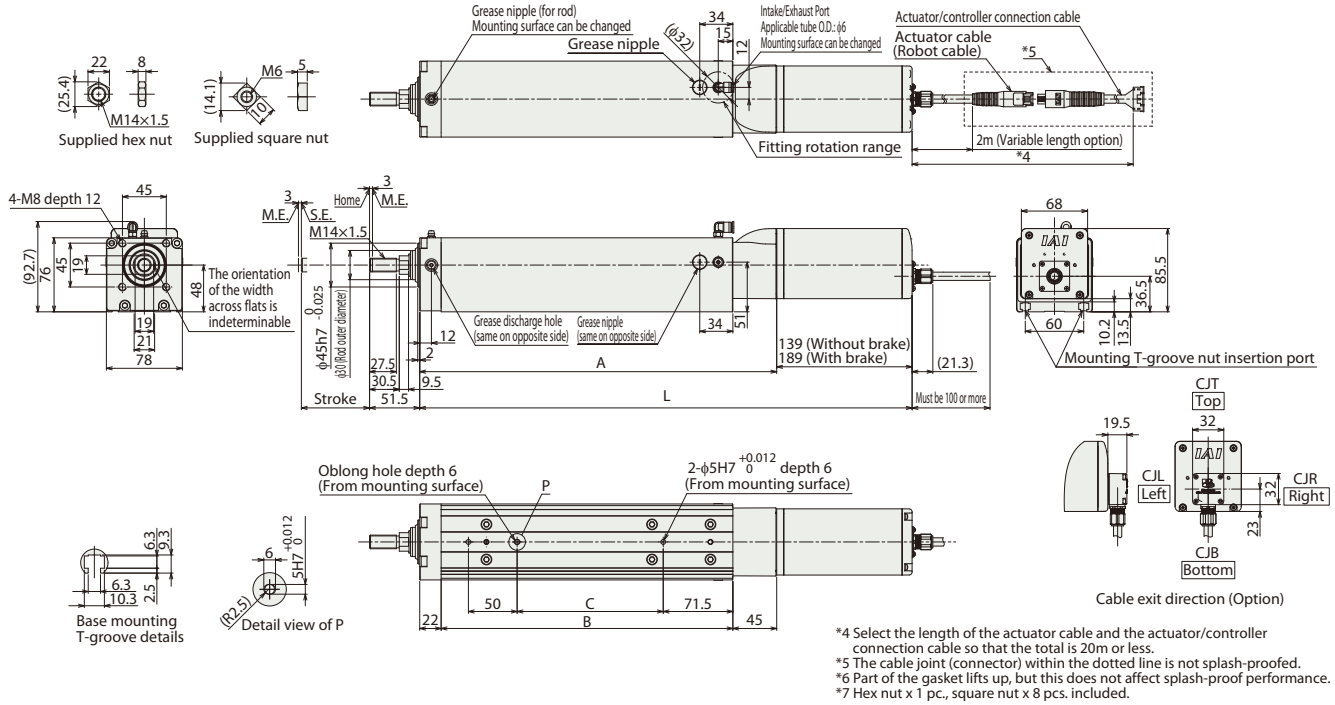

- *4 Select the length of the actuator cable and the actuator/controller connection cable so that the total is 20m or less.
- *5 The cable joint (connector) within the dotted line is not splash-proofed.
- *6 Part of the gasket lifts up, but this does not affect splash-proof performance.
- *7 Hex nut x 1 pc., square nut x 8 pcs. included.

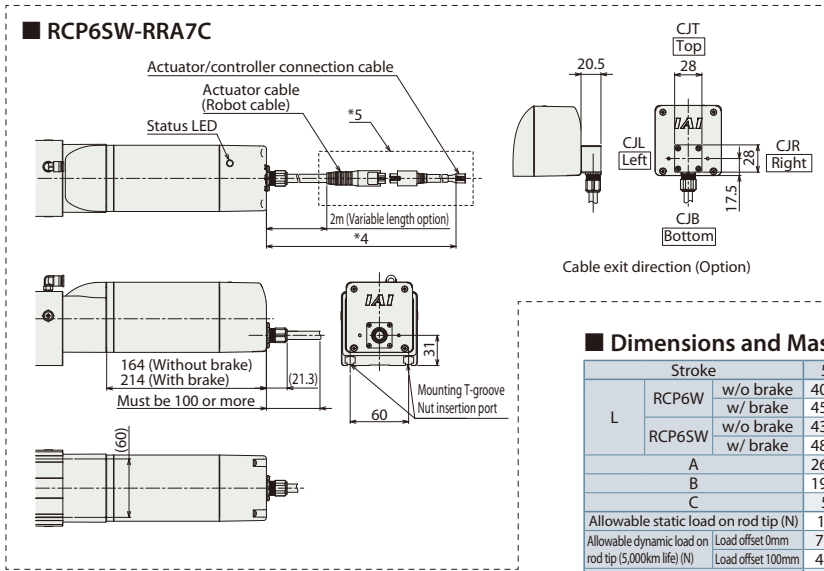

■ Rod Deflection of RCP6(S)W-RA7C (Reference Values)

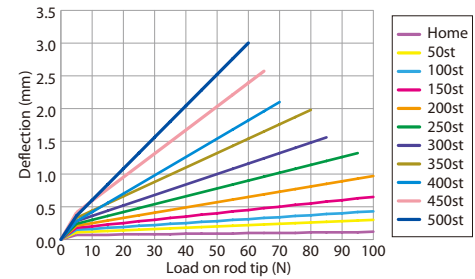

■ Dimensions and Mass by Stroke

L	Stroke	Dimensions (mm)									
		50	100	150	200	250	300	350	400	450	500
RCP6W	w/o brake	405.5	455.5	505.5	555.5	605.5	655.5	705.5	755.5	805.5	855.5
	w/ brake	455.5	505.5	555.5	605.5	655.5	705.5	755.5	805.5	855.5	905.5
	w/o brake	430.5	480.5	530.5	580.5	630.5	680.5	730.5	780.5	830.5	880.5
	w/ brake	480.5	530.5	580.5	630.5	680.5	730.5	780.5	830.5	880.5	930.5
RCP6SW	A	266.5	316.5	366.5	416.5	466.5	516.5	566.5	616.5	666.5	716.5
	B	199.5	249.5	299.5	349.5	399.5	449.5	499.5	549.5	599.5	649.5
	C	50	100	150	200	250	300	350	400	450	500
	Allowable static load on rod tip (N)	175	147	126	111	98.6	88.7	80.6	73.8	68	63
Allowable dynamic load on rod tip (5,000km life) (N)	Load offset 0mm	75.7	62.6	53.1	46.0	40.5	36.1	32.5	29.4	26.9	24.7
	Load offset 100mm	49.8	45.1	40.5	36.5	33.1	30.2	27.7	25.5	23.6	21.9
Allowable static torque on rod tip (N·m)	w/o brake	17.6	14.7	12.7	11.2	9.9	9.0	8.2	7.5	6.94	6.45
	w/ brake	5.0	4.5	4.0	3.6	3.3	3.0	2.8	2.5	2.32	2.16
Mass (kg)	w/o brake	5.0	5.5	6.0	6.5	6.9	7.4	7.9	8.4	8.9	9.4
	w/ brake	5.4	5.9	6.4	6.9	7.3	7.8	8.3	8.8	9.3	9.8
	w/o brake	5.2	5.7	6.2	6.7	7.1	7.6	8.1	8.6	9.1	9.6
	w/ brake	5.6	6.1	6.6	7.1	7.5	8.0	8.5	9.0	9.5	10.0

* Please refer to P.251 and P.252 for more information on component materials.

② Applicable Controllers

The RCP6 series actuators can be operated by the controllers indicated below. Please select the type depending on your intended use. * Please refer to P.271 for more information about the built-in controller of RCP6S series.

Name	External view	Max. number of controlled axes	Input power	Control method				Maximum number of positioning points	Reference page
				Positioner	Pulse train	Program	Network * Option		
PCON-CYB/PLB/POB		1	DC24V	●	●	—	Network cannot be selected	64	Please contact IAI for more information.
PCON-CB/CGB		1		* Option	●	—	DeviceNet MECHATROLINK CC-Link EtherCAT EtherNet/IP CompoNet	512 (768 for network spec.)	See P.255
MCON-C/CG		8		* Option	* Option	—		Note: The type of compatible networks will vary depending on the controller. Please refer to reference page for more information.	256
MCON-LC/LCG		6		—	—	●	SSCNET III/H		256
MSEL-PC/PG		4	Single-phase 100 ~ 230 VAC	—	—	●	—	30,000	Please contact IAI for more information.
RCM-P6PC		1	—	Usable within the RCP6S Gateway system.				768	See P.279

* For the MCON controller, high-output enabled operation is only available if "high-output setting" is selected as an option. The maximum connectable axes with high-output enabled are C: 4 and LC: 3.

Foreword
Slider Type
Wide Slider Type
Rod Type
Radial Cylinder
Wide Radial Cylinder
Table Type
Cleanroom Slider
Cleanroom Wide Slider
Dust/Splash-Proof Rod
Dust/Splash-Proof Radial Cylinder
Dust/Splash-Proof Wide Radial Cylinder
Options
Reference Data
Controller

RCP6(S)W-RRR8C

Dust/Splash-Proof Spec
Battery-less Absolute
Motor Unit Type
Coupled Motor
Body Width 85 mm
24v Stepper Motor

Model Specification Items	Series	Type	Encoder Type	Motor Type	Lead	Stroke	Applicable Controller/I/O Type	Cable Length	Options
	RCP6W: Separate Controller RCP6SW: Built-in Controller	WA: Battery-less Absolute	60P: Stepper Motor 60□ Size	20 :20mm 10 :10mm 5 : 5mm	50:50mm 700:700mm (Every 50mm)	[RCP6W] P4 : PCON-CFB/ CGFB [RCP6SW] SE: SIO Type	N : None P : 1m S : 3m M : 5m X□□ : Specified Length R□□ : Robot Cable	Please refer to the options table below.	

* RCP6 does not include a controller. RCP6S includes a built-in controller.
* Please refer to P.19 for more information about the model specification items.

Radial Load Applicable

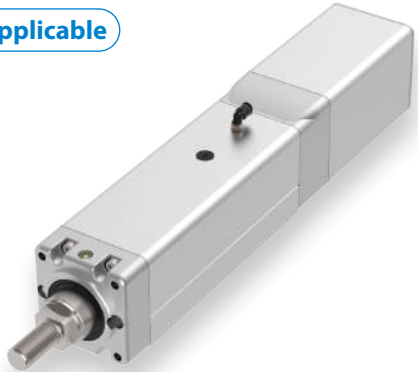
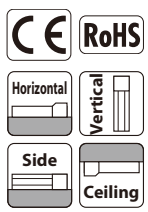

*Some limitations may apply to horizontal/side/ceiling mountings depending on the model. See page 204. Please contact IAI for more information.

- POINT Selection Notes**
- (1) The maximum acceleration/deceleration is 0.1G for lead 5 and 0.2G for lead 10/20.
 - (2) The actuator specifications displays the payload's maximum value, but it will vary depending on the acceleration and speed. Please refer to the "Selection Guidelines" (Tables of Payload by Speed/Acceleration) on P.236 for more details.
 - (3) The radial cylinder is equipped with a built-in guide. Please refer to the graphs shown on P.243 and after for the allowable load mass.
 - (4) Please refer to P.205 for performing push-motion operation.
 - (5) For RCP6SW (built-in controller type), please limit the duty cycle to 70% or less.
 - (6) The service life of an actuator varies depending on the payload when using vertically. Please refer to P. 206 for more information.
 - (7) The cable joint connector is not splash-proofed, so it should be located where there is no splash.

Correlation Diagrams of Speed and Payload

If the ambient temperature is 5°C or below, the speed will be lower than when it exceeds 5°C.

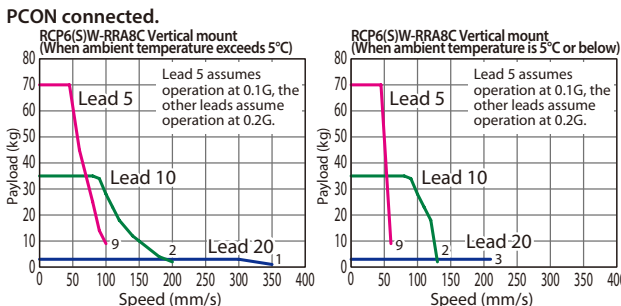
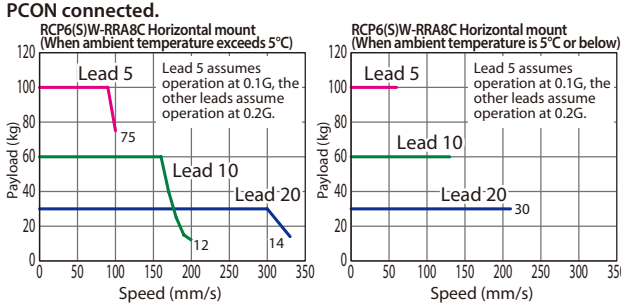

Actuator Specifications

Model Number	Lead (mm)	Max. Payload		Max. Push Force (N)**	Stroke (mm)
		Horizontal (kg)*	Vertical (kg)		
RCP6(S)W-RRR8C-WA-60P-20-①-②-③-④	20	30	3	500	50~700 (Every 50mm)
RCP6(S)W-RRR8C-WA-60P-10-①-②-③-④	10	60	35	1,000	
RCP6(S)W-RRR8C-WA-60P-5-①-②-③-④	5	100	70	2,000	

* Horizontal external guide rail required for horizontal payload.
** Push force only available during push mode w / limited speed.

Lead (mm)	Stroke and Max Speed (Unit: mm/s)						
	50	100~450 (Every 50mm)	500	550	600	650	700
20	280 [210]	350<330> [210]	320 [210]	280 [210]	240 [210]	220 [210]	220 [210]
10	200 [130]	180 [130]	160 [130]	140 [130]	120 [120]	110 [110]	110 [110]
5	100 [60]	90 [60]	80 [60]	70 [60]	60 [60]	55 [55]	55 [55]

Values in brackets < > are for vertical use.
Values in brackets [] are when ambient temperature is 5°C or below.

Legend: ① Stroke ② Applicable controllers/I/O type ③ Cable length ④ Options

① Stroke					
Stroke (mm)	RCP6W	RCP6SW	Stroke (mm)	RCP6W	RCP6SW
50	○	○	400	○	○
100	○	○	450	○	○
150	○	○	500	○	○
200	○	○	550	○	○
250	○	○	600	○	○
300	○	○	650	○	○
350	○	○	700	○	○

③ Cable Length			
Cable Type	Cable Code	RCP6W	RCP6SW
Standard	P(1m)	○	○
	S(3m)	○	○
	M(5m)	○	○
Specified length	X06 (6m) ~X10 (10m)	○	○
	X11 (11m) ~X15 (15m)	○	○
	X16 (16m) ~X18 (18m)	○	○
Robot cable	R01 (1m) ~R03 (3m)	○	○
	R04 (4m) ~R05 (5m)	○	○
	R06 (6m) ~R10 (10m)	○	○
	R11 (11m) ~R15 (15m)	○	○
	R16 (16m) ~R18 (18m)	○	○

* Select the length of the actuator cable and the actuator/controller connection cable so that the total is 20m or less.
* Please refer to P. 267 and 283 for more information regarding the maintenance cables.

④ Options		
Name	Option Code	Reference Page
Actuator cable length 2m	Not specified	See P.197
Actuator cable length 5m	AC5	See P.197
Actuator cable length 10m	AC10	See P.197
Actuator cable length 15m	AC15	See P.197
Brake	B	See P.197
Cable exit direction (Bottom)	CJB	See P.197
Cable exit direction (Left)	CJL	See P.197
Cable exit direction (Right)	CJR	See P.197
Cable exit direction (Top)	CJT	See P.197
Flange	FL	See P.198
Tip adapter (Internal thread)	NFA	See P.201
Non-motor end specification	NM	See P.202

Actuator Specifications	
Item	Description
Drive system	Ball screw φ16mm, rolled C10
Positioning repeatability	±0.01 mm
Lost motion	0.1 mm or less
Rod	φ40mm
Rod non-rotation precision*	0 degrees
Allowable load and torque on rod tip	See P. 243
Rod tip overhang distance	150mm or less
Protective structure	IP65 (IEC 60529/JIS C 0920)
Ambient operating temp. & humidity	0~40°C, 85% RH or less (Non-condensing)

* Rod's angular displacement in rotational direction with no load applied to the rod.

CAD drawings can be downloaded from our website.
www.intelligentactuator.com



- *1 When the rod is returning to its home position, please be careful of interference from surrounding objects, as it will travel until it reaches the M.E.
- M.E: Mechanical end S.E: Stroke end
- *2 The direction of width across flats varies depending on the product.
- *3 When fixing the actuator using a front bracket or flange, please make sure that there is no external force applied to the main body.

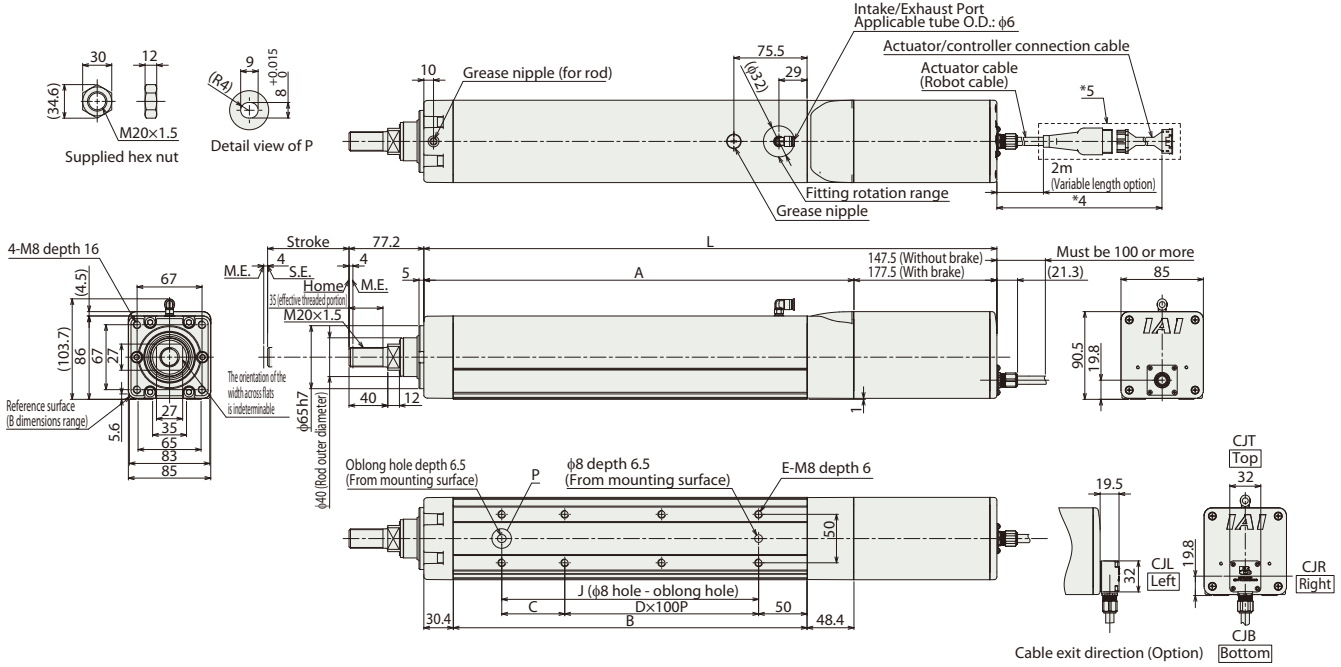

- *4 Select the length of the actuator cable and the actuator/controller connection cable so that the total is 20m or less.
- *5 The cable joint (connector) within the dotted line is not splash-proofed.

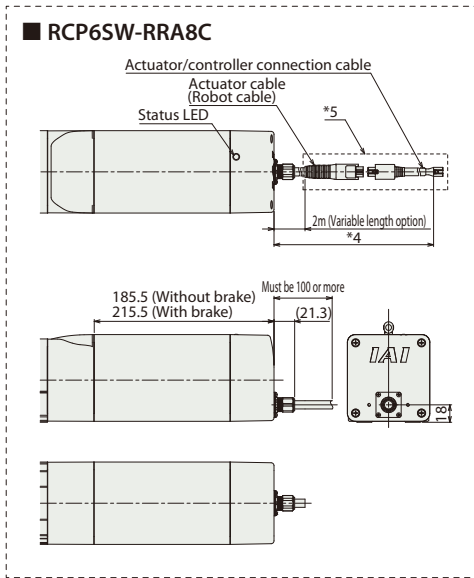

■ Rod Deflection of RCP6(S)W-RRR8C (Reference Values)

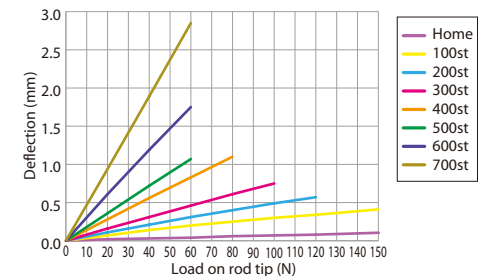

■ Dimensions and Mass by Stroke

Stroke		50	100	150	200	250	300	350	400	450	500	550	600	650	700	
L	RCP6W	w/o brake	441.3	491.3	541.3	591.3	641.3	691.3	741.3	791.3	841.3	891.3	941.3	991.3	1,041.3	1,091.3
		w/ brake	471.3	521.3	571.3	621.3	671.3	721.3	771.3	821.3	871.3	921.3	971.3	1,021.3	1,071.3	1,121.3
	RCP6SW	w/o brake	479.3	529.3	579.3	629.3	679.3	729.3	779.3	829.3	879.3	929.3	979.3	1,029.3	1,079.3	1,129.3
		w/ brake	509.3	559.3	609.3	659.3	709.3	759.3	809.3	859.3	909.3	959.3	1,009.3	1,059.3	1,109.3	1,159.3
A		293.8	343.8	393.8	443.8	493.8	543.8	593.8	643.8	693.8	743.8	793.8	843.8	893.8	943.8	
B		215	265	315	365	415	465	515	565	615	665	715	765	815	865	
C		115	65	115	65	115	65	115	65	115	65	115	65	115	65	
D		0	1	1	2	2	3	3	4	4	5	5	6	6	7	
E		4	6	6	8	8	10	10	12	12	14	14	16	16	18	
J		115	165	215	265	315	365	415	465	515	565	615	665	715	765	
Allowable static load on rod tip (N)		222	186	159	139	124	111	101	92.1	84.7	78.4	72.8	68	63.7	59.8	
Allowable dynamic load on rod tip (5,000km life) (N)		93.0	76.3	64.7	56.0	49.2	43.8	39.3	35.6	32.4	29.7	27.3	25.2	23.3	21.7	
Offset 100mm		72.0	61.6	53.9	48.0	43.0	38.9	35.4	32.3	29.7	27.4	25.3	23.5	21.9	20.4	
Allowable static torque on rod tip (N·m)		22.3	18.7	16.1	14.1	12.6	11.3	10.3	9.4	8.7	8.1	7.6	7.1	6.7	6.3	
Allowable dynamic torque on rod tip (N·m)		7.2	6.2	5.4	4.8	4.3	3.9	3.5	3.2	3.0	2.7	2.5	2.4	2.2	2.0	
Mass (kg)	RCP6W	w/o brake	6.8	7.3	7.8	8.3	8.8	9.2	9.7	10.2	10.7	11.2	11.7	12.1	12.6	13.1
		w/ brake	7.4	7.9	8.4	8.9	9.4	9.8	10.3	10.8	11.3	11.8	12.3	12.7	13.2	13.7
	RCP6SW	w/o brake	7.1	7.6	8.1	8.6	9.1	9.5	10.0	10.5	11.0	11.5	12.0	12.4	12.9	13.4
		w/ brake	7.7	8.2	8.7	9.2	9.7	10.1	10.6	11.1	11.6	12.1	12.6	13.0	13.5	14.0

* Please refer to P.252 for more information on component materials.

② Applicable Controllers

The RCP6 series actuators can be operated by the controllers indicated below. Please select the type depending on your intended use.* Please refer to P.271 for more information about the built-in controller of RCP6S series.

Name	External view	Max. number of controlled axes	Input power	Control method			Maximum number of positioning points	Reference page
				Positioner	Pulse train	Program		
PCON-CFB/CGFB		1	DC24V	●	●	-	512 (768 for network spec.)	See P.255
				* Option	* Option			

Control method options: DeviceNet, CompoNet, EtherNet/IP, CC-Link, MECHATROLINK, EtherCAT, CANopen.

RCP6(S)W-RRA4R

Dust/Splash-Proof Spec
Battery-less Absolute
Motor Unit Type
Side-mounted Motor
Body Width 45* mm
24v Stepper Motor

Model Specification Items

Series	Type	Encoder Type	Motor Type	Lead	Stroke	Applicable Controller/I/O Type	Cable Length	Options
RCP6W: Separate Controller RCP6SW: Built-in Controller	RRA4R	WA: Battery-less Absolute	35P: Stepper Motor 35□ Size	10 : 10mm 5 : 5mm 2.5 : 2.5mm	50:50mm 400:400mm (Every 50mm)	[RCP6W] P3 : PCON MCON MSEL P5 : RCM-P6PC [RCP6SW] SE: SIO Type	N : None P : 1m S : 3m M : 5m XC□ : Specified Length R□□ : Robot Cable	Please refer to the options table below. * Please make sure to specify MT when ordering the side-mounted motor type.

* RCP6 does not include a controller. RCP6S includes a built-in controller.
* Please refer to P.19 for more information about the model specification items.

* Body width does not include the width of the side-mounted motor.

Radial Load Applicable

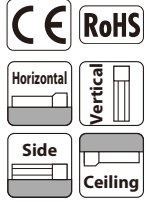

*Some limitations may apply to horizontal/side/ceiling mountings depending on the model. See page 204. Please contact IAI for more information.

POINT Selection Notes

- (1) The maximum acceleration/deceleration is 1G for horizontal, and 0.5G for vertical use.
- (2) The actuator specifications displays the payload's maximum value, but it will vary depending on the acceleration and speed. Please refer to the "Selection Guidelines" (Tables of Payload by Speed/Acceleration) on P.237 for more details.
- (3) The radial cylinder is equipped with a built-in guide. Please refer to the graphs shown on P.243 and after for the allowable load mass.
- (4) Please refer to P.205 for performing push-motion operation.
- (5) The cable joint connector is not splash-proofed, so it should be located where there is no splash.

Correlation Diagrams of Speed and Payload

If the ambient temperature is 5°C or below, the speed will be lower than when it exceeds 5°C.

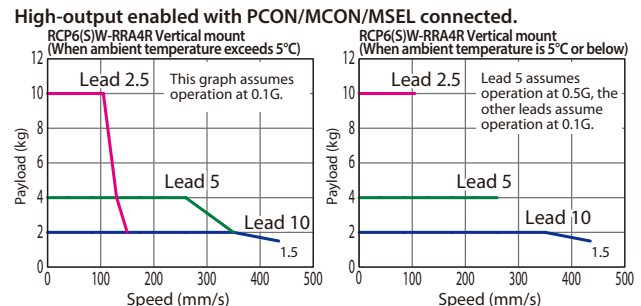
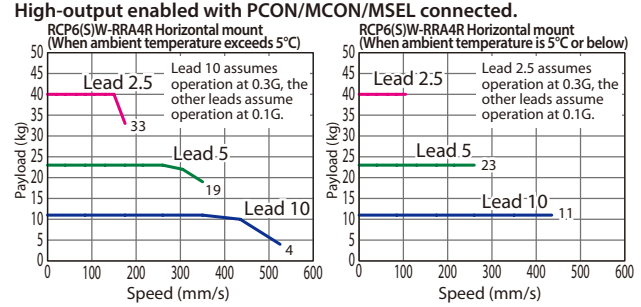

Actuator Specifications

Model Number	Lead (mm)	Max. Payload		Max. Push Force (N)**	Stroke (mm)	Stroke and Max Speed (Unit: mm/s)	
		Horizontal (kg)*	Vertical (kg)			Lead (mm)	50~350 (Every 50mm)
RCP6(S)W-RRA4R-WA-35P-10-①-②-③-④	10	11	2	77	50~400 (Every 50mm)	10	525 <435> [435]
RCP6(S)W-RRA4R-WA-35P-5-①-②-③-④	5	23	4	155		5	350 [260] 340 [260]
RCP6(S)W-RRA4R-WA-35P-2.5-①-②-③-④	2.5	40	10	310		2.5	175 <150> [105] 170 <150> [105]

Legend: ① Stroke ② Applicable controllers/I/O type ③ Cable length ④ Options

* Horizontal external guide rail required for horizontal payload.
** Push force only available during push mode w / limited speed.

Values in brackets <> are for vertical use.
Values in brackets [] are when ambient temperature is 5°C or below.

① Stroke

Stroke (mm)	RCP6W	RCP6SW	Stroke (mm)	RCP6W	RCP6SW
50	○	○	250	○	○
100	○	○	300	○	○
150	○	○	350	○	○
200	○	○	400	○	○

④ Options

Name	Option Code	Reference Page
Actuator cable length 2m	Not specified	See P.197
Actuator cable length 5m	AC5	See P.197
Actuator cable length 10m	AC10	See P.197
Actuator cable length 15m	AC15	See P.197
Brake	B	See P.197
Cable exit direction (Left)	CJL	See P.197
Cable exit direction (Outside)	CJO	See P.197
Cable exit direction (Right)	CJR	See P.197
Flange	FL	See P.198
Foot bracket	FT	See P.199
Tip adapter (Flange)	FFA	See P.197
Tip adapter (Internal thread)	NFA	See P.201
Tip adapter (Keyway)	KFA	See P.201
Motor side-mounted on top	MT	See P.201
Non-motor end specification	NM	See P.202
T-slot nut bar	NTB	See P.202

* Be sure to confirm with the "Selection Notes (P.204)" when selecting options.

③ Cable Length

Cable Type	Cable Code	RCP6W			RCP6SW
		P3	P5	SE	
Standard	P (1m)	○	○	○	
	S (3m)	○	○	○	
	M (5m)	○	○	○	
	X06 (6m) ~ X10 (10m)	○	○	○	
Specified length	X11 (11m) ~ X15 (15m)	○	○	○	
	X16 (16m) ~ X18 (18m)	○	○	○	
	R01 (1m) ~ R03 (3m)	○	○	○	
	R04 (4m) ~ R05 (5m)	○	○	○	
Robot cable	R06 (6m) ~ R10 (10m)	○	○	○	
	R11 (11m) ~ R15 (15m)	○	○	○	
	R16 (16m) ~ R18 (18m)	○	○	○	

* Select the length of the actuator cable and the actuator/controller connection cable so that the total is 20m or less.
* Please refer to P. 267 and 283 for more information regarding the maintenance cables.

Actuator Specifications

Item	Description
Drive system	Ball screw φ8mm, rolled C10
Positioning repeatability	±0.01mm
Lost motion	0.1mm or less
Rod	φ20mm
Rod non-rotation precision*	0 degrees
Allowable load and torque on rod tip	See P. 243
Rod tip overhang distance	100mm or less
Protective structure	IP65 (IEC 60529/JIS C 0920)
Ambient operating temp. & humidity	0~40°C, 85% RH or less (Non-condensing)

* Rod's angular displacement in rotational direction with no load applied to the rod.

CAD drawings can be downloaded from our website.
www.intelligentactuator.com



*1 When the rod is returning to its home position, please be careful of interference from surrounding objects, as it will travel until it reaches the M.E.
M.E: Mechanical end S.E: Stroke end
*2 The direction of width across flats varies depending on the product.

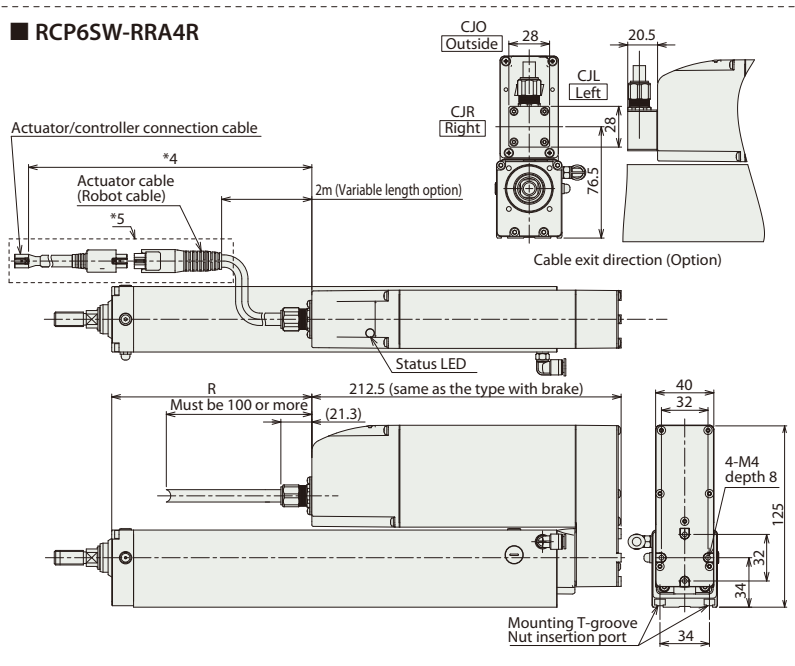
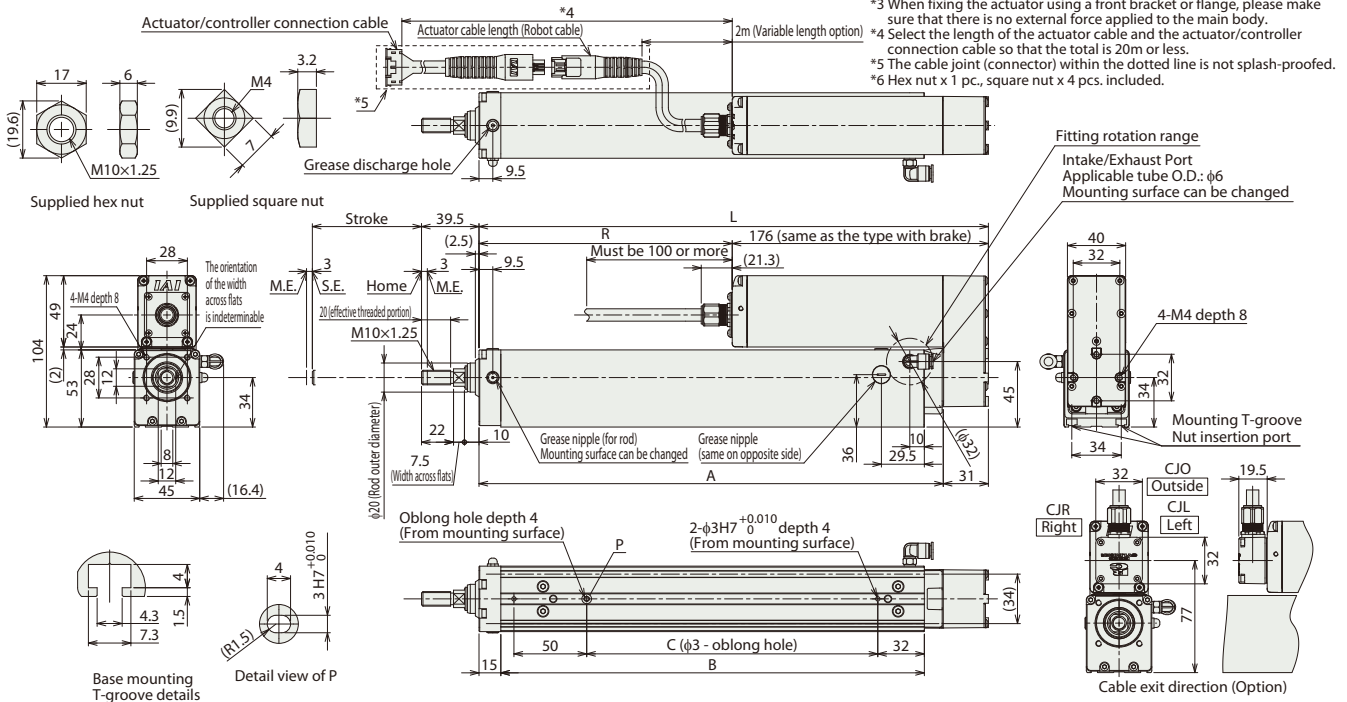

■ Rod Deflection of RCP6(S)W-RRA4R (Reference Values)

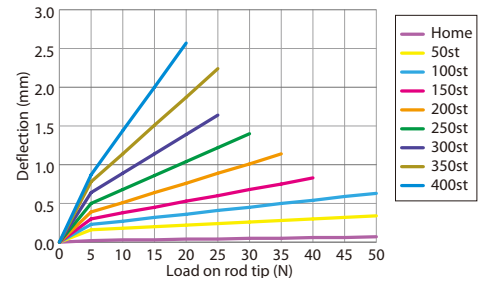

■ Dimensions and Mass by Stroke

Stroke	50	100	150	200	250	300	350	400
L	200	250	300	350	400	450	500	550
A	169	219	269	319	369	419	469	519
B	141	191	241	291	341	391	441	491
C	50	100	150	200	250	300	350	400
R	RCP6W	24	74	124	174	224	274	324
	RCP6SW	-12.5	37.5	87.5	137.5	187.5	237.5	287.5
Allowable static load on rod tip (N)	Offset 0mm	63.4	50.7	42.1	36	31.3	27.6	24.6
	Offset 100mm	17.9	15.5	13.4	11.6	10.2	9.0	8.0
Allowable static torque on rod tip (N·m)	w/o brake	6.4	5.1	4.3	3.7	3.2	2.9	2.6
	w/ brake	1.7	1.5	1.3	1.1	1.0	0.9	0.7
Mass (kg)	RCP6W	1.6	1.8	2.0	2.2	2.4	2.6	2.8
	RCP6SW	1.7	1.9	2.1	2.3	2.5	2.7	2.9

* Please refer to P.251 for more information on component materials.

* If the length for R is negative in the table below, the length of the actuator body is shorter than the motor unit.

② Applicable Controllers

The RCP6 series actuators can be operated by the controllers indicated below. Please select the type depending on your intended use. * Please refer to P.271 for more information about the built-in controller of RCP6S series.

Name	External view	Max. number of controlled axes	Input power	Control method				Maximum number of positioning points	Reference page
				Positioner	Pulse train	Program	Network * Option		
PCON-CYB/PLB/POB		1	DC24V	●	●	-	Network cannot be selected	64	Please contact IAI for more information.
PCON-CB/CGB		1		* Option	* Option	-	DeviceNet MECHATROLINK CC-Link EtherCAT EtherNet/IP CANopen CompoNet	512 (768 for network spec.)	See P.255
MCON-C/CG		8		This model is network-compatible only.				256	Please contact IAI for more information.
MCON-LC/LCG		6		-	-	●	Note: The type of compatible networks will vary depending on the controller. Please refer to reference page for more information.	256	Please contact IAI for more information.
MSEL-PC/PG		4	Single-phase 100 ~ 230 VAC	-	-	●		30,000	Please contact IAI for more information.
RCM-P6PC		1	Usable within the RCP6S Gateway system.				768	See P.279	

* For the MCON controller, high-output enabled operation is only available if "high-output setting" is selected as an option. The maximum connectable axes with high-output enabled are C: 4 and LC: 3.

Foreword
Slider Type
Wide Slider Type
Rod Type
Radial Cylinder
Wide Radial Cylinder
Table Type
Cleanroom Slider
Cleanroom Wide Slider
Dust/Splash-Proof Rod
Dust/Splash-Proof Radial Cylinder
Dust/Splash-Proof Wide Radial Cylinder
Options
Reference Data
Controller

RCP6(S)W-RRA6R

Dust/Splash-Proof Spec | Battery-less Absolute | Motor Unit Type | Side-mounted Motor | Body Width 65* mm | 24v Stepper Motor

Model Specification Items	Series	Type	Encoder Type	Motor Type	Lead	Stroke	Applicable Controller/I/O Type	Cable Length	Options
	RCP6W: Separate Controller RCP6SW: Built-in Controller	RRA6R	WA	42P	12: 12mm 6: 6mm 3: 3mm	50: 50mm 400: 400mm (Every 50mm)	[RCP6W] P3: PCON MCON MSEL P5: RCM-P6PC [RCP6SW] SE: SIO Type	N: None P: 1m S: 3m M: 5m XC: Specified Length R: Robot Cable	Please refer to the options table below. * Please make sure to specify MT when ordering the side-mounted motor type.

* RCP6 does not include a controller. RCP6S includes a built-in controller.
* Please refer to P.19 for more information about the model specification items.

Radial Load Applicable

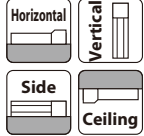

*Some limitations may apply to horizontal/side/ceiling mountings depending on the model. See page 204. Please contact IAI for more information.

- POINT Selection Notes**
- (1) The maximum acceleration/deceleration is 1G for horizontal, and 0.5G for vertical use.
 - (2) The actuator specifications displays the payload's maximum value, but it will vary depending on the acceleration and speed. Please refer to the "Selection Guidelines" (Tables of Payload by Speed/Acceleration) on P.237 for more details.
 - (3) The radial cylinder is equipped with a built-in guide. Please refer to the graphs shown on P.243 and after for the allowable load mass.
 - (4) Please refer to P.205 for performing push-motion operation.
 - (5) Depending on the ambient operating temperature, duty control is necessary for the RCP6SW (built-in controller type) with lead 3/6. Please refer to P.247 for more information.
 - (6) The cable joint connector is not splash-proofed, so it should be located where there is no splash.

Correlation Diagrams of Speed and Payload

If the ambient temperature is 5°C or below, the speed will be lower than when it exceeds 5°C.

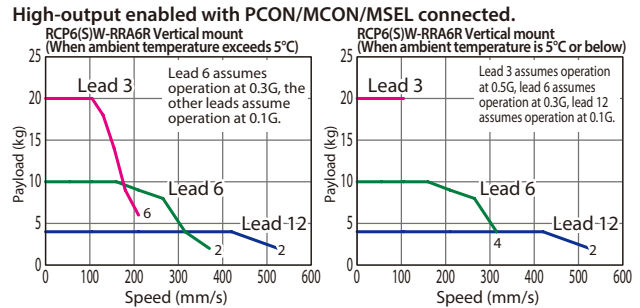
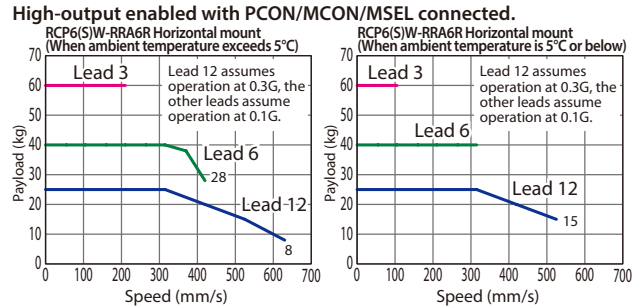

Actuator Specifications

Lead and Payload

Model Number	Lead (mm)	Max. Payload		Max. Push Force (N)**	Stroke (mm)
		Horizontal (kg)*	Vertical (kg)		
RCP6(S)W-RRA6R-WA-42P-12-①-②-③-④	12	25	4	93	50~400 (Every 50mm)
RCP6(S)W-RRA6R-WA-42P-6-①-②-③-④	6	40	10	185	
RCP6(S)W-RRA6R-WA-42P-3-①-②-③-④	3	60	20	370	

Legend: ① Stroke ② Applicable controllers/I/O type ③ Cable length ④ Options

Stroke and Max Speed (Unit: mm/s)

Lead (mm)	50~400 (Every 50mm)
12	630 <525> [525]
6	420 <370> [315]
3	210 [105]

Values in brackets <> are for vertical use.
Values in brackets [] are when ambient temperature is 5°C or below.

① Stroke

Stroke (mm)	RCP6W	RCP6SW	Stroke (mm)	RCP6W	RCP6SW
50	○	○	250	○	○
100	○	○	300	○	○
150	○	○	350	○	○
200	○	○	400	○	○

④ Options

Name	Option Code	Reference Page
Actuator cable length 2m	Not specified	See P.197
Actuator cable length 5m	AC5	See P.197
Actuator cable length 10m	AC10	See P.197
Actuator cable length 15m	AC15	See P.197
Brake	B	See P.197
Cable exit direction (Left)	CJL	See P.197
Cable exit direction (Outside)	CJO	See P.197
Cable exit direction (Right)	CJR	See P.197
Flange	FL	See P.198
Foot bracket	FT	See P.199
Tip adapter (Flange)	FFA	See P.197
Tip adapter (Internal thread)	NFA	See P.201
Tip adapter (Keyway)	KFA	See P.201
Motor side-mounted on top	MT	See P.201
Non-motor end specification	NM	See P.202
T-slot nut bar	NTB	See P.202

* Be sure to confirm with the "Selection Notes (P.204)" when selecting options.

③ Cable Length

Cable Type	Cable Code	RCP6W			RCP6SW
		P3	P5	SE	
Standard	P (1m)	○	○	○	
	S (3m)	○	○	○	
	M (5m)	○	○	○	
	X06 (6m) ~ X10 (10m)	○	○	○	
Specified length	X11 (11m) ~ X15 (15m)	○	○	○	
	X16 (16m) ~ X18 (18m)	○	○	○	
	R01 (1m) ~ R03 (3m)	○	○	○	
	R04 (4m) ~ R05 (5m)	○	○	○	
Robot cable	R06 (6m) ~ R10 (10m)	○	○	○	
	R11 (11m) ~ R15 (15m)	○	○	○	
	R16 (16m) ~ R18 (18m)	○	○	○	

* Select the length of the actuator cable and the actuator/controller connection cable so that the total is 20m or less.
* Please refer to P. 267 and 283 for more information regarding the maintenance cables.

Actuator Specifications

Item	Description
Drive system	Ball screw φ10mm, rolled C10
Positioning repeatability	±0.01mm
Lost motion	0.1mm or less
Rod	φ25mm
Rod non-rotation precision*	0 degrees
Allowable load and torque on rod tip	See P. 243
Rod tip overhang distance	100mm or less
Protective structure	IP65 (IEC 60529/JIS C 0920)
Ambient operating temp. & humidity	0~40°C, 85% RH or less (Non-condensing)

* Rod's angular displacement in rotational direction with no load applied to the rod.

CAD drawings can be downloaded from our website.
www.intelligentactuator.com



- *1 When the rod is returning to its home position, please be careful of interference from surrounding objects, as it will travel until it reaches the M.E. M.E: Mechanical end S.E: Stroke end
- *2 The direction of width across flats varies depending on the product.
- *3 When fixing the actuator using a front bracket or flange, please make sure that there is no external force applied to the main body.
- *4 Select the length of the actuator cable and the actuator/controller connection cable so that the total is 20m or less.
- *5 The cable joint (connector) within the dotted line is not splash-proofed.
- *6 Hex nut x 1 pc., square nut x 4 pcs. included.

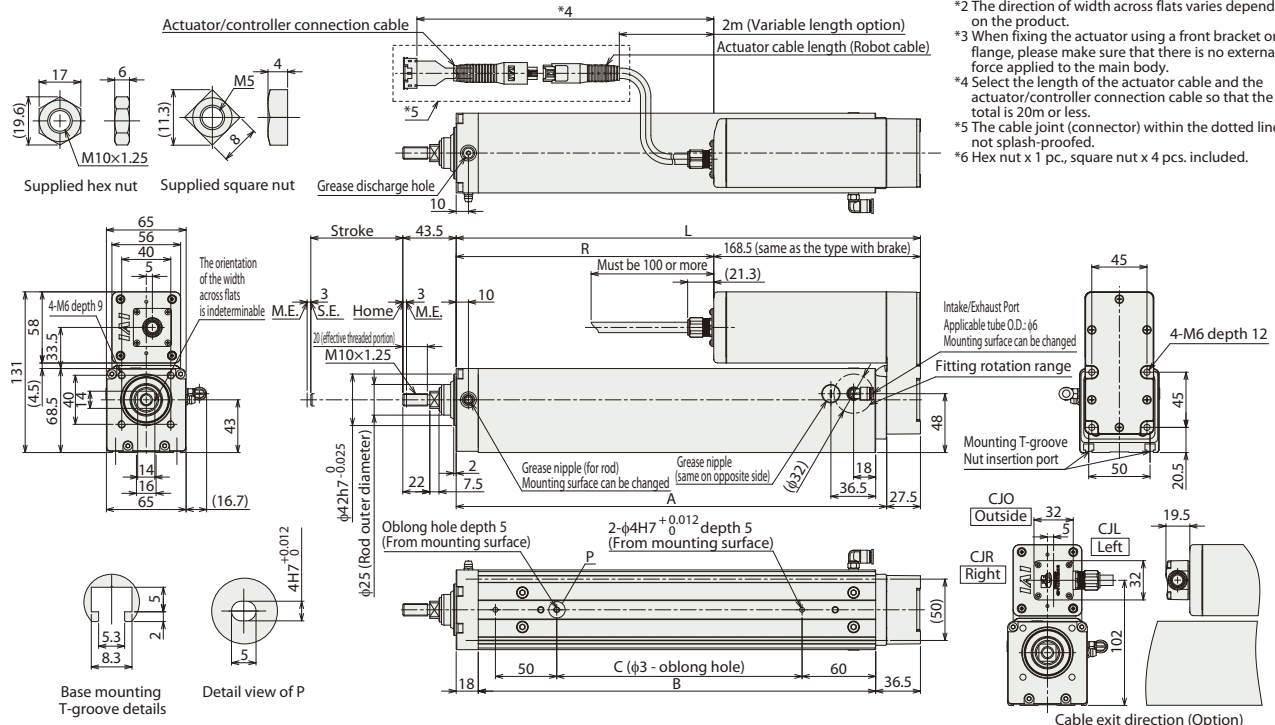

■ RCP6SW-RRR6R

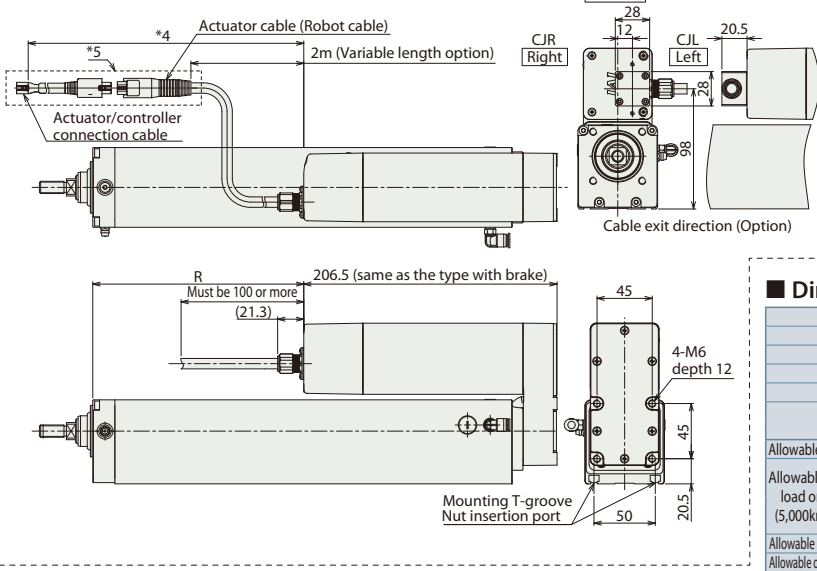

■ Rod Deflection of RCP6(S)W-RRR6R (Reference Values)

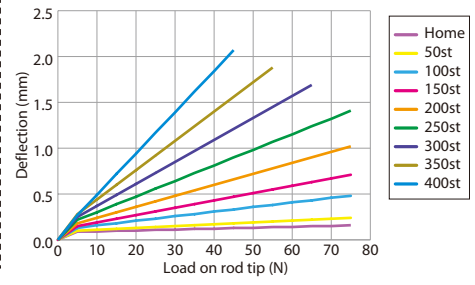

■ Dimensions and Mass by Stroke

Stroke	50	100	150	200	250	300	350	400
L	228.5	278.5	328.5	378.5	428.5	478.5	528.5	578.5
A	201	251	301	351	401	451	501	551
B	174	224	274	324	374	424	474	524
C	50	100	150	200	250	300	350	400
R	RCP6W	60	110	160	210	260	310	360
	RCP6SW	22	72	122	172	222	272	322
Allowable static load on rod tip (N)	Offset 0mm	144	117	99.0	85.4	75.0	66.7	59.9
	Offset 100mm	38.8	34.0	29.7	26.2	23.2	20.8	18.7
Allowable dynamic load on rod tip (5,000km life) (N)	Offset 0mm	58.1	46.4	38.3	32.4	27.9	24.4	21.5
	Offset 100mm	14.5	11.8	10.0	8.7	7.6	6.8	6.2
Allowable static torque on rod tip (N-m)	w/o brake	3.1	3.4	3.8	4.2	4.5	4.9	5.2
	w/ brake	3.2	3.5	3.9	4.3	4.6	5.0	5.3
Mass (kg)	RCP6W	3.3	3.6	4.0	4.4	4.7	5.1	5.4
	RCP6SW	3.4	3.7	4.1	4.5	4.8	5.2	5.5

* Please refer to P.251 for more information on component materials.

② Applicable Controllers

The RCP6 series actuators can be operated by the controllers indicated below. Please select the type depending on your intended use. * Please refer to P.271 for more information about the built-in controller of RCP6S series.

Name	External view	Max. number of controlled axes	Input power	Control method				Maximum number of positioning points	Reference page
				Positioner	Pulse train	Program	Network * Option		
PCON-CYB/PLB/POB		1	DC24V	●	●	-	Network cannot be selected	64	Please contact IAI for more information.
PCON-CB/CGB		1		* Option	* Option	-	 Note: The type of compatible networks will vary depending on the controller. Please refer to reference page for more information.	512 (768 for network spec.)	See P.255
MCON-C/CG		8		This model is network-compatible only.				256	Please contact IAI for more information.
MCON-LC/LCG		6		-	-	●	256	Please contact IAI for more information.	
MSEL-PC/PG		4	Single-phase 100 ~ 230 VAC	-	-	●	30,000	Please contact IAI for more information.	
RCM-P6PC		1		Usable within the RCP6S Gateway system.				768	See P.279

* For the MCON controller, high-output enabled operation is only available if "high-output setting" is selected as an option. The maximum connectable axes with high-output enabled are C: 4 and LC: 3.

Foreword
 Slider Type
 Wide Slider Type
 Rod Type
 Radial Cylinder
 Wide Radial Cylinder
 Table Type
 Cleanroom Slider
 Cleanroom Wide Slider
 Dust/Splash-Proof Rod
 Dust/Splash-Proof Radial Cylinder
 Dust/Splash-Proof Wide Radial Cylinder
 Options
 Reference Data
 Controller

RCP6(S)W-RAA7R

Dust/Splash-Proof Spec
Battery-less Absolute
Motor Unit Type
Side-mounted Motor
Body Width 78* mm
24v Stepper Motor

Model Specification Items	Series	Type	Encoder Type	Motor Type	Lead	Stroke	Applicable Controller/I/O Type	Cable Length	Options
	RCP6W: Separate Controller RCP6SW: Built-in Controller	RRA7R	WA	56P	16 : 16mm 8 : 8mm 4 : 4mm	50:50mm 500:500mm (Every 50mm)	[RCP6W] P3 : PCON MCON MSEL P5 : RCM-P6PC [RCP6SW] SE: SIO Type	N : None P : 1m S : 3m M : 5m XC□ : Specified Length R□□ : Robot Cable	Please refer to the options table below. * Please make sure to specify MT when ordering the side-mounted motor type.

* RCP6 does not include a controller. RCP6S includes a built-in controller.
* Please refer to P.19 for more information about the model specification items.

* Body width does not include the width of the side-mounted motor.

Radial Load Applicable

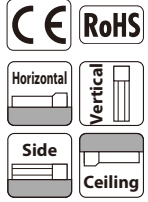

*Some limitations may apply to horizontal/side/ceiling mountings depending on the model. See page 204. Please contact IAI for more information.

- POINT Selection Notes**
- (1) The maximum acceleration/deceleration is 1G for horizontal, and 0.5G for vertical use.
 - (2) The actuator specifications displays the payload's maximum value, but it will vary depending on the acceleration and speed. Please refer to the "Selection Guidelines" (Tables of Payload by Speed/Acceleration) on P.238 for more details.
 - (3) The radial cylinder is equipped with a built-in guide. Please refer to the graphs shown on P.243 and after for the allowable load mass.
 - (4) Please refer to P.205 for performing push-motion operation.
 - (5) Depending on the ambient operating temperature, duty control is necessary for the RCP6SW (built-in controller type) with lead 4/8/16. Please refer to P.247 for more information.
 - (6) The cable joint connector is not splash-proofed, so it should be located where there is no splash.

Correlation Diagrams of Speed and Payload

If the ambient temperature is 5°C or below, the speed will be lower than when it exceeds 5°C.

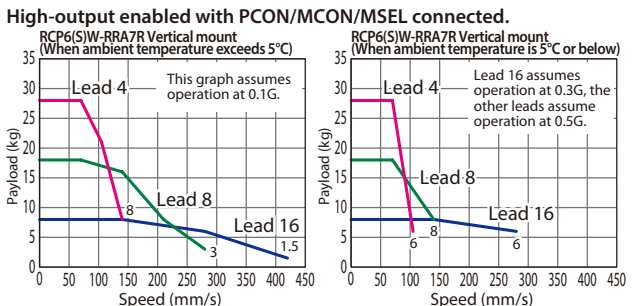
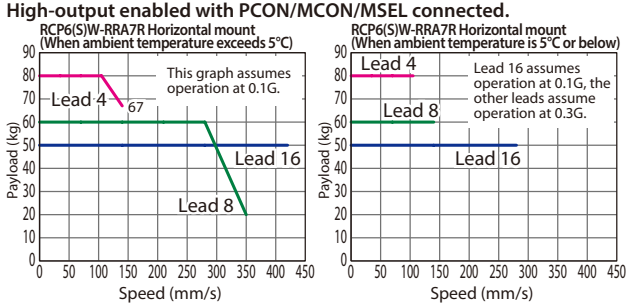

Actuator Specifications

Lead and Payload

Model Number	Lead (mm)	Max. Payload		Max. Push Force (N)**	Stroke (mm)
		Horizontal (kg)*	Vertical (kg)		
RCP6(S)W-RAA7R-WA-56P-16-①-②-③-④	16	50	8	273	50~500 (Every 50mm)
RCP6(S)W-RAA7R-WA-56P-8-①-②-③-④	8	60	18	547	
RCP6(S)W-RAA7R-WA-56P-4-①-②-③-④	4	80	28	1,094	

Legend: ① Stroke ② Applicable controllers/I/O type ③ Cable length ④ Options

Stroke and Max Speed

Lead (mm)	50~500 (Every 50mm)
16	420 [280]
8	350 <280> [140]
4	140 [105]

Values in brackets < > are for vertical use.
Values in brackets [] are when ambient temperature is 5°C or below.

① Stroke

Stroke (mm)	RCP6W	RCP6SW	Stroke (mm)	RCP6W	RCP6SW
50	○	○	300	○	○
100	○	○	350	○	○
150	○	○	400	○	○
200	○	○	450	○	○
250	○	○	500	○	○

④ Options

Name	Option Code	Reference Page
Actuator cable length 2m	Not specified	See P.197
Actuator cable length 5m	AC5	See P.197
Actuator cable length 10m	AC10	See P.197
Actuator cable length 15m	AC15	See P.197
Brake	B	See P.197
Cable exit direction (Left)	CJL	See P.197
Cable exit direction (Outside)	CJO	See P.197
Cable exit direction (Right)	CJR	See P.197
Flange	FL	See P.198
Foot bracket	FT	See P.199
Tip adapter (Flange)	FFA	See P.197
Tip adapter (Internal thread)	NFA	See P.201
Tip adapter (Keyway)	KFA	See P.201
Motor side-mounted on top	MT	See P.201
Non-motor end specification	NM	See P.202
T-slot nut bar	NTB	See P.202

* Be sure to confirm with the "Selection Notes (P.204)" when selecting options.

③ Cable Length

Cable Type	Cable Code	RCP6W			RCP6SW
		P3	P5	SE	
Standard	P (1m)	○	○	○	
	S (3m)	○	○	○	
	M (5m)	○	○	○	
	X06 (6m)~ X10 (10m)	○	○	○	
Specified length	X11 (11m)~ X15 (15m)	○	○	○	
	X16 (16m)~ X18 (18m)	○	○	○	
	R01 (1m)~ R03 (3m)	○	○	○	
	R04 (4m)~ R05 (5m)	○	○	○	
Robot cable	R06 (6m)~ R10 (10m)	○	○	○	
	R11 (11m)~ R15 (15m)	○	○	○	
	R16 (16m)~ R18 (18m)	○	○	○	

* Select the length of the actuator cable and the actuator/controller connection cable so that the total is 20m or less.
* Please refer to P. 267 and 283 for more information regarding the maintenance cables.

Actuator Specifications

Item	Description
Drive system	Ball screw φ12mm, rolled C10
Positioning repeatability	±0.01mm
Lost motion	0.1mm or less
Rod	φ30mm
Rod non-rotation precision*	0 degrees
Allowable load and torque on rod tip	See P. 243
Rod tip overhang distance	150mm or less
Protective structure	IP65 (IEC 60529/JIS C 0920)
Ambient operating temp. & humidity	0~40°C, 85% RH or less (Non-condensing)

* Rod's angular displacement in rotational direction with no load applied to the rod.

CAD drawings can be downloaded from our website.
www.intelligentactuator.com



- *1 When the rod is returning to its home position, please be careful of interference from surrounding objects, as it will travel until it reaches the M.E.
M.E: Mechanical end S.E: Stroke end
- *2 The direction of width across flats varies depending on the product.
- *3 When fixing the actuator using a front bracket or flange, please make sure that there is no external force applied to the main body.
- *4 Select the length of the actuator cable and the actuator/controller connection cable so that the total is 20m or less.
- *5 The cable joint (connector) within the dotted line is not splash-proofed.
- *6 Hex nut x 1 pc., square nut x 8 pcs. included.

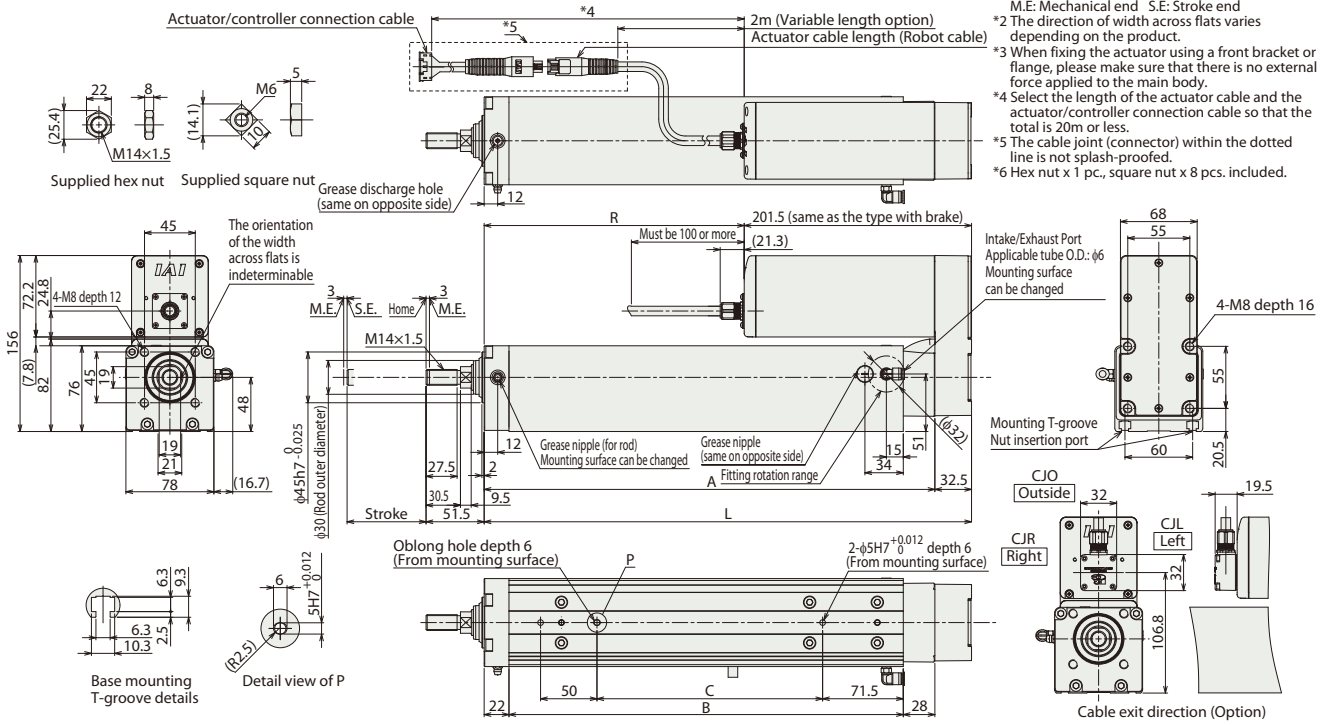

RCP6SW-RRR7R

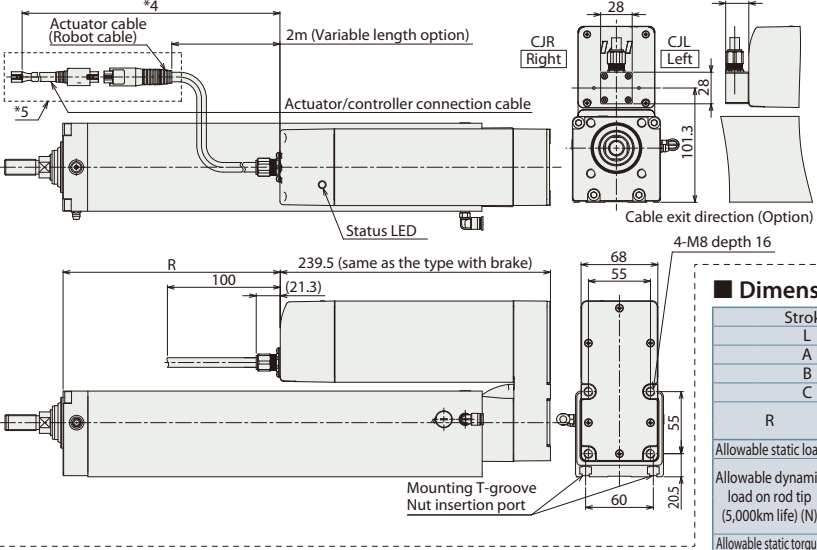

■ Rod Deflection of RCP6(S)W-RRR7R (Reference Values)

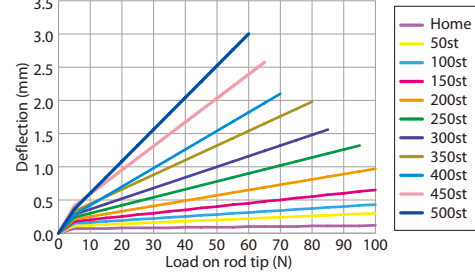

■ Dimensions and Mass by Stroke

Stroke	50	100	150	200	250	300	350	400	450	500	
L	282	332	382	432	482	532	582	632	682	732	
A	249.5	299.5	349.5	399.5	449.5	499.5	549.5	599.5	649.5	699.5	
B	199.5	249.5	299.5	349.5	399.5	449.5	499.5	549.5	599.5	649.5	
C	50	100	150	200	250	300	350	400	450	500	
R	RCP6W	80.5	130.5	180.5	230.5	280.5	330.5	380.5	430.5	480.5	530.5
	RCP6SW	42.5	92.5	142.5	192.5	242.5	292.5	342.5	392.5	442.5	492.5
Allowable static load on rod tip (N)	Offset 0mm	175	147	126	111	98.6	88.7	80.6	73.8	68.0	63.0
	Offset 100mm	49.8	45.1	40.5	36.5	33.1	30.2	27.7	25.5	23.6	21.9
Allowable static torque on rod tip (N·m)	w/o brake	5.0	4.5	4.0	3.6	3.3	3.0	2.8	2.5	2.32	2.16
	w/ brake	5.6	6.1	6.6	7.1	7.5	8.0	8.5	9.0	9.5	10.0
Mass (kg)	RCP6W	5.7	6.2	6.7	7.2	7.6	8.1	8.6	9.1	9.6	10.1
	RCP6SW	5.8	6.3	6.8	7.3	7.7	8.2	8.7	9.2	9.7	10.2
		5.9	6.4	6.9	7.4	7.8	8.3	8.8	9.3	9.8	10.3

* Please refer to P.251 and P.252 for more information on component materials.

② Applicable Controllers

The RCP6 series actuators can be operated by the controllers indicated below. Please select the type depending on your intended use. * Please refer to P.271 for more information about the built-in controller of RCP6S series.

Name	External view	Max. number of controlled axes	Input power	Control method				Maximum number of positioning points	Reference page
				Positioner	Pulse train	Program	Network * Option		
PCON-CYB/PLB/POB		1	DC24V	●	●	—	Network cannot be selected	64	Please contact IAI for more information.
PCON-CB/CGB		1		* Option	* Option	—	DeviceNet MECHATROLINK CC-Link EtherCAT EtherNet/IP PROFINET CompoNet	512 (768 for network spec.)	See P.255
MCON-C/CG		8		This model is network-compatible only.				256	Please contact IAI for more information.
MCON-LC/LCG		6		—	—	●	Note: The type of compatible networks will vary depending on the controller. Please refer to reference page for more information.	256	Please contact IAI for more information.
MSEL-PC/PG		4	Single-phase 100 ~ 230 VAC	—	—	●		30,000	Please contact IAI for more information.
RCM-P6PC		1		Usable within the RCP6S Gateway system.				768	See P.279

* For the MCON controller, high-output enabled operation is only available if "high-output setting" is selected as an option. The maximum connectable axes with high-output enabled are C: 4 and LC: 3.

Foreword
Slider Type
Wide Slider Type
Rod Type
Radial Cylinder
Wide Radial Cylinder
Table Type
Cleanroom Slider
Cleanroom Wide Slider
Dust/Splash-Proof Rod
Dust/Splash-Proof Radial Cylinder
Dust/Splash-Proof Wide Radial Cylinder
Options
Reference Data
Controller

RCP6(S)W-RRR8R

Dust/Splash-Proof Spec
Battery-less Absolute
Motor Unit Type
Side-mounted Motor
Body Width 85* mm
24v Stepper Motor

Model Specification Items	Series	Type	Encoder Type	Motor Type	Lead	Stroke	Applicable Controller/I/O Type	Cable Length	Options
	<input type="checkbox"/> RCP6W: Separate Controller <input type="checkbox"/> RCP6SW: Built-in Controller	<input type="checkbox"/> RRA8R	<input type="checkbox"/> WA: Battery-less Absolute	<input type="checkbox"/> 60P: Stepper Motor 60□ Size	<input type="checkbox"/> 20: 20mm <input type="checkbox"/> 10: 10mm <input type="checkbox"/> 5: 5mm	<input type="checkbox"/> 50: 50mm <input type="checkbox"/> 700: 700mm (Every 50mm)	<input type="checkbox"/> [RCP6W] <input type="checkbox"/> P4: PCON-CFB/CGFB <input type="checkbox"/> [RCP6SW] <input type="checkbox"/> SE: SIO Type	<input type="checkbox"/> N: None <input type="checkbox"/> P: 1m <input type="checkbox"/> S: 3m <input type="checkbox"/> M: 5m <input type="checkbox"/> X□□: Specified Length <input type="checkbox"/> R□□: Robot Cable	* Body width does not include the width of the side-mounted motor. Please refer to the options table below. * Please make sure to specify either ML or MR when ordering the side-mounted motor type.

* RCP6 does not include a controller. RCP6S includes a built-in controller.
* Please refer to P.18 for more information about the model specification items.

Radial Load Applicable

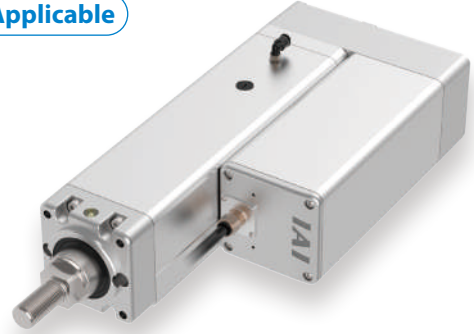

The figure above is the motor side-mounted to left (ML).

*Some limitations may apply to horizontal/side/ceiling mountings depending on the model. See page 204. Please contact IAI for more information.

- POINT Selection Notes**
- (1) The maximum acceleration/deceleration is 0.1G for lead 5 and 0.2G for lead 10/20.
 - (2) The actuator specifications displays the payload's maximum value, but it will vary depending on the acceleration and speed. Please refer to the "Selection Guidelines" (Tables of Payload by Speed/Acceleration) on P.238 for more details.
 - (3) The radial cylinder is equipped with a built-in guide. Please refer to the graphs shown on P.243 and after for the allowable load mass.
 - (4) Please refer to P.205 for performing push-motion operation.
 - (5) For RCP6SW (built-in controller type), please limit the duty cycle to 70% or less.
 - (6) The service life of an actuator varies depending on the payload when using vertically. Please refer to P. 206 for more information.
 - (7) Install the cable joint connector in locations where it will not be exposed to water, as it is not splash-proofed.

Correlation Diagrams of Speed and Payload

If the ambient temperature is 5°C or below, the speed will be lower than when it exceeds 5°C.

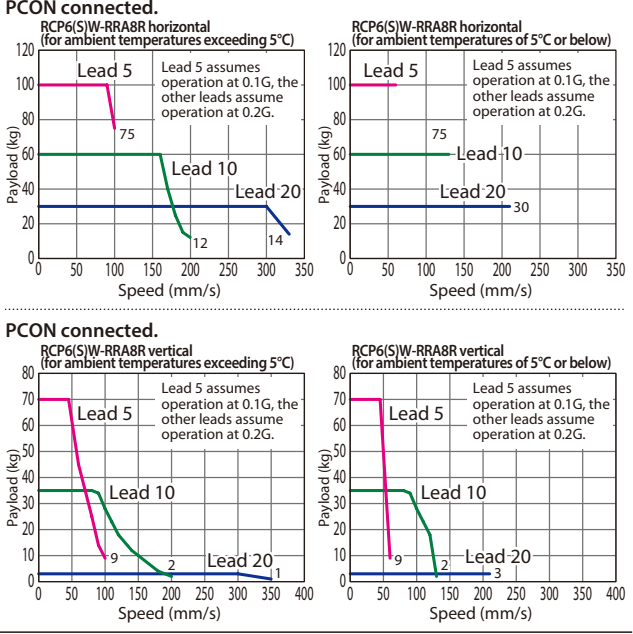

Actuator Specifications

Lead and Payload

* Horizontal external guide rail required for horizontal payload.
** Push force only available during push mode w / limited speed.

Model Number	Lead (mm)	Max. Payload		Max. Push Force (N)**	Stroke (mm)
		Horizontal (kg)*	Vertical (kg)		
RCP6(S)W-RRR8R-WA-60P-20-①-②-③-④	20	30	3	500	50~700 (Every 50mm)
RCP6(S)W-RRR8R-WA-60P-10-①-②-③-④	10	60	35	1,000	
RCP6(S)W-RRR8R-WA-60P-5-①-②-③-④	5	100	70	2,000	

Legend: ① Stroke ② Applicable controllers/I/O type ③ Cable length ④ Options

Stroke and Max Speed

(Unit: mm/s)

Lead (mm)	50	100~450 (Every 50mm)	500	550	600	650	700
20	280 [210]	350 <330> [210]		320 [210]	280 [210]	240 [210]	220 [210]
10	200 [130]	180 [130]	160 [130]	140 [130]	120 [120]	110 [110]	
5	100 [60]	90 [60]	80 [60]	70 [60]	60 [60]	55 [55]	

Values in brackets <> are for vertical use.
Values in brackets [] are for ambient temperatures of 5°C or below.

① Stroke

Stroke (mm)	RCP6W	RCP6SW	Stroke (mm)	RCP6W	RCP6SW
50	○	○	400	○	○
100	○	○	450	○	○
150	○	○	500	○	○
200	○	○	550	○	○
250	○	○	600	○	○
300	○	○	650	○	○
350	○	○	700	○	○

③ Cable Length

Cable Type	Cable Code	RCP6W	RCP6SW
Standard	P(1m)	○	○
	S(3m)	○	○
	M(5m)	○	○
Specified length	X06 (6m) ~ X10 (10m)	○	○
	X11 (11m) ~ X15 (15m)	○	○
	X16 (16m) ~ X18 (18m)	○	○
	R01 (1m) ~ R03 (3m)	○	○
Robot cable	R04 (4m) ~ R05 (5m)	○	○
	R06 (6m) ~ R10 (10m)	○	○
	R11 (11m) ~ R15 (15m)	○	○
	R16 (16m) ~ R18 (18m)	○	○

* Select the actuator cable and the cable connecting the actuator and controller so that their total length will not exceed 20m.

* Please refer to P. 267 and 283 for more information regarding the maintenance cables.

④ Options

Name	Option Code	Reference Page
Actuator cable length 2m	Not specified	See P.197
Actuator cable length 5m	AC5	See P.197
Actuator cable length 10m	AC10	See P.197
Actuator cable length 15m	AC15	See P.197
Brake	B	See P.197
Cable exit direction (Bottom)	CJB	See P.197
Cable exit direction (Outside)	CJO	See P.197
Cable exit direction (Top)	CJT	See P.197
Flange	FL	See P.198
Tip adapter (Internal thread)	NFA	See P.201
Motor side-mounted to left (standard)	ML	See P.201
Motor side-mounted to right	MR	See P.201
Non-motor end specification	NM	See P.202

* When selecting options, be sure to consult the Selection Notes (P.204).

Actuator Specifications

Item	Description
Drive system	Ball screw φ16mm, rolled C10
Positioning repeatability	±0.01mm
Lost motion	0.1mm or less
Rod	φ40mm
Rod non-rotation precision*	0 degrees
Allowable load and torque on rod tip	See P. 243
Rod tip overhang distance	150mm or less
Protective structure	IP65 (IEC 60529/JIS C 0920)
Ambient operating temp. & humidity	0~40°C, 85% RH or less (Non-condensing)

* Rod's angular displacement in rotational direction with no load applied to the rod.

CAD drawings can be downloaded from our website.
www.intelligentactuator.com



- *1 When the rod is returning to its home position, please be careful of interference from surrounding objects, as it will travel until it reaches the M.E.
- M.E: Mechanical end
- S.E: Stroke end
- *2 The direction of width across flats varies depending on the product.
- *3 When fixing the actuator using a front bracket or flange, please make sure that there is no external force applied to the main body.
- *4 Select the actuator cable and the cable connecting the actuator and controller so that their total length will not exceed 20m.
- *5 The cable relay section within the dashed lines (cable joint connector) is not splash-proofed.

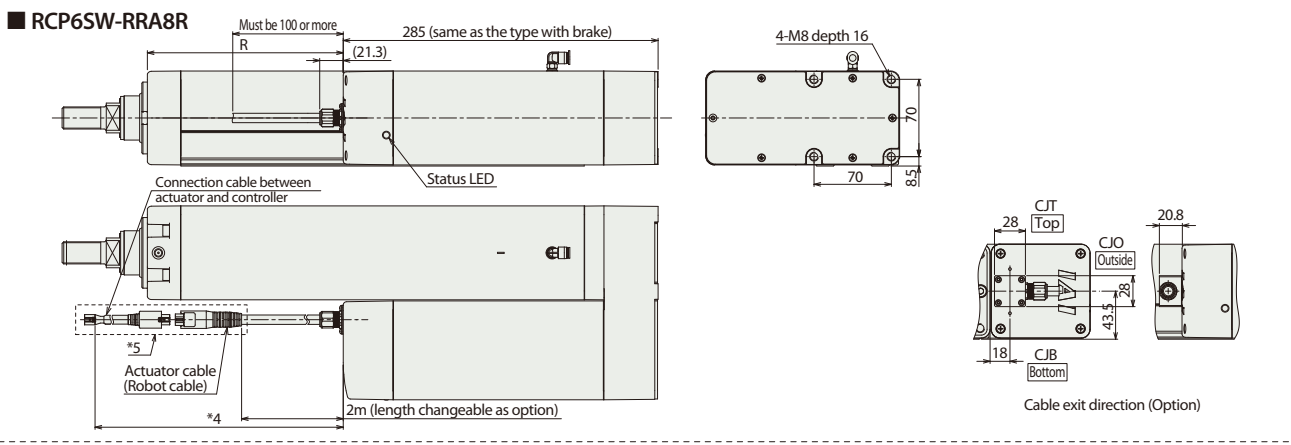
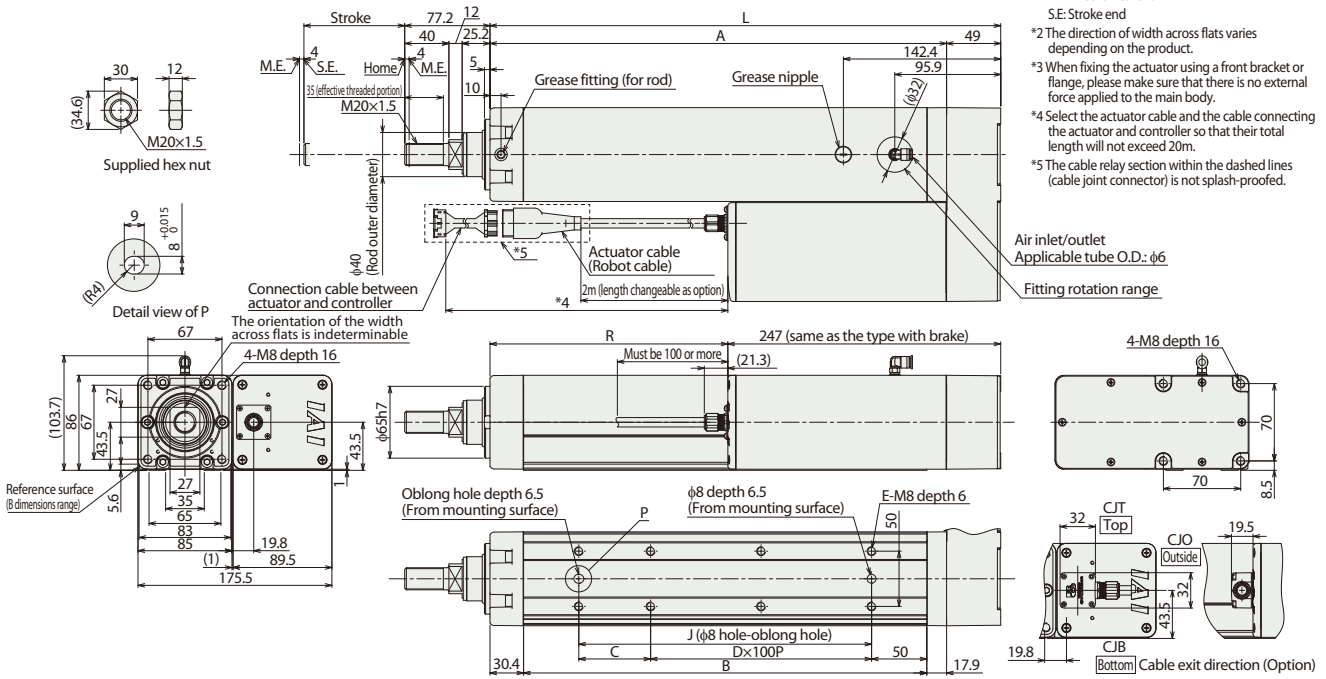

■ Rod Deflection of RCP6(S)W-RAA8R (Reference Values)

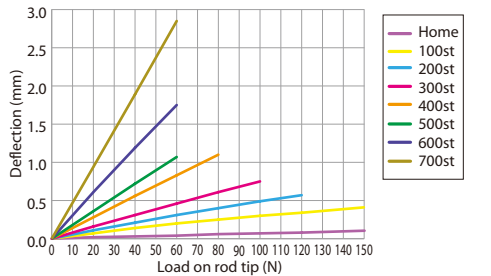

■ Dimensions and Mass by Stroke

Stroke	50	100	150	200	250	300	350	400	450	500	550	600	650	700
L	312.3	362.3	412.3	462.3	512.3	562.3	612.3	662.3	712.3	762.3	812.3	862.3	912.3	962.3
A	263.3	313.3	363.3	413.3	463.3	513.3	563.3	613.3	663.3	713.3	763.3	813.3	863.3	913.3
B	215	265	315	365	415	465	515	565	615	665	715	765	815	865
C	115	65	115	65	115	65	115	65	115	65	115	65	115	65
D	0	1	1	2	2	3	3	4	5	5	6	6	7	7
E	4	6	6	8	8	10	10	12	12	14	14	16	16	18
J	115	165	215	265	315	365	415	465	515	565	615	665	715	765
R	RCP6W	65.3	115.3	165.3	215.3	265.3	315.3	365.3	415.3	465.3	515.3	565.3	615.3	665.3
	RCP6SW	27.3	77.3	127.3	177.3	227.3	277.3	327.3	377.3	427.3	477.3	527.3	577.3	627.3
Allowable static load on rod tip (N)	222	186	159	139	124	111	101	92.1	84.7	78.4	72.8	68.0	63.7	59.8
Allowable dynamic load on rod tip (5,000km life) (N)	Load offset 0mm	93.0	76.3	64.7	56.0	49.2	43.8	39.3	35.6	32.4	29.7	27.3	25.2	23.3
	Load offset 100mm	72.0	61.6	53.9	48.0	43.0	38.9	35.4	32.3	29.7	27.4	25.3	23.5	21.9
Allowable static torque on rod tip (N·m)	22.3	18.7	16.1	14.1	12.6	11.3	10.3	9.4	8.7	8.1	7.6	7.1	6.7	6.3
Allowable dynamic torque on rod tip (N·m)	w/o brake	7.2	6.2	5.4	4.8	4.3	3.9	3.5	3.2	3.0	2.7	2.5	2.4	2.2
	w/ brake	8.0	8.5	9.0	9.5	10.0	10.4	10.9	11.4	11.9	12.4	12.9	13.3	13.8
Mass (kg)	RCP6W	8.3	8.8	9.3	9.8	10.3	10.7	11.2	11.7	12.2	12.7	13.2	13.6	14.1
	RCP6SW	8.4	8.9	9.4	9.9	10.4	10.8	11.3	11.8	12.3	12.8	13.3	13.7	14.2
		8.6	9.1	9.6	10.1	10.6	11.0	11.5	12.0	12.5	13.0	13.5	13.9	14.4

* Please refer to P.252 for part materials.

② Applicable Controllers

The RCP6 series actuators can be operated by the controllers indicated below. Please select the type depending on your intended use.* Please refer to P.271 for more information about the built-in controller of RCP6S series.

Name	External view	Max. number of controlled axes	Input power	Control method			Maximum number of positioning points	Reference page
				Positioner	Pulse train	Program		
PCON-CFB/CGFB		1	DC24V	●	●	-	512 (768 for network spec.)	See P.255
				* Option	* Option			
Control method Network * Option DeviceNet CompoNet EtherNet/IP CC-Link MECHATROLINK EtherCAT 								

Foreword
 Slider Type
 Wide Slider Type
 Rod Type
 Radial Cylinder
 Wide Radial Cylinder
 Table Type
 Cleanroom Slider
 Cleanroom Wide Slider
 Dust/Splash-Proof Rod
 Dust/Splash-Proof Radial Cylinder
 Dust/Splash-Proof Wide Radial Cylinder
 Options
 Reference Data
 Controller

RCP6(S)W-WRA10C

Dust/Splash-Proof Spec | Battery-less Absolute | Motor Unit Type | Coupled Motor | Body Width 100 mm | 24v Stepper Motor

Model Specification Items

Series	Type	Encoder Type	Motor Type	Lead	Stroke	Applicable Controller/I/O Type	Cable Length	Options
RCP6W: Separate Controller RCP6SW: Built-in Controller	WRA10C	WA	35P	10 : 10mm 5 : 5mm 2.5 : 2.5mm	50:50mm 500:500mm (Every 50mm)	[RCP6W] P3 : PCON MCON MSEL P5 : RCM-P6PC [RCP6SW] SE: SIO Type	N : None P : 1m S : 3m M : 5m X□ : Specified Length R□ : Robot Cable	Please refer to the options table below.

* RCP6 does not include a controller. RCP6S includes a built-in controller.
* Please refer to P.20 for more information about the model specification items.

Radial Load Applicable

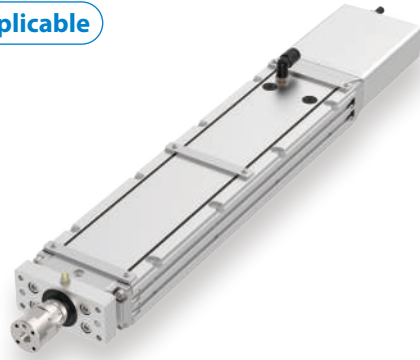
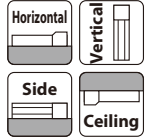

*Some limitations may apply to horizontal/side/ceiling mountings depending on the model. See page 204. Please contact IAI for more information.

- POINT Selection Notes**
- The maximum acceleration/deceleration is 1G for horizontal, and 0.5G for vertical use.
 - The actuator specifications displays the payload's maximum value, but it will vary depending on the acceleration and speed. Please refer to the "Selection Guidelines" (Tables of Payload by Speed/Acceleration) on P.239 for more details.
 - The radial cylinder is equipped with a built-in guide. Please refer to the graphs shown on P.246 and after for the allowable load mass.
 - Please refer to P.205 for performing push-motion operation.
 - The cable joint connector is not splash-proofed, so it should be located where there is no splash.
 - The RCP6SW with built-in controller does not have a teaching tool connection port. Connect the teaching tool to the gateway unit and configure parameter data etc. via the gateway unit.

Correlation Diagrams of Speed and Payload

If the ambient temperature is 5°C or below, the speed will be lower than when it exceeds 5°C.

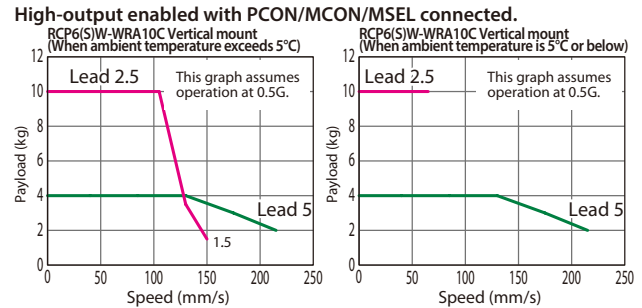
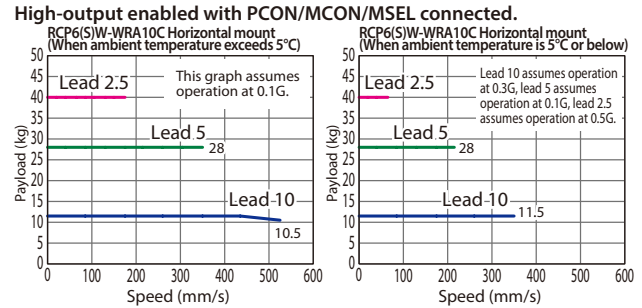

Actuator Specifications

Lead and Payload

Model Number	Lead (mm)	Max. Payload		Max. Push Force (N)**	Stroke (mm)
		Horizontal (kg)*	Vertical (kg)		
RCP6(S)W-WRA10C-WA-35P-10-①-②-③-④	10	11.5	-	77	50~500 (Every 50mm)
RCP6(S)W-WRA10C-WA-35P-5-①-②-③-④	5	28	4	155	
RCP6(S)W-WRA10C-WA-35P-2.5-①-②-③-④	2.5	40	10	310	

Legend: ① Stroke ② Applicable controllers/I/O type ③ Cable length ④ Options

Stroke and Max Speed (Unit: mm/s)

Lead (mm)	50~400 (Every 50mm)			450	500
	350	290	240		
10	<315> [215]	<215> [215]	<215> [215]	490 [350]	490 [350]
5	<175> [150]	<150> [65]	<150> [65]	145 [65]	120 [65]

Values in brackets < > are for vertical use.
Values in brackets [] are when ambient temperature is 5°C or below.

① Stroke

Stroke (mm)	RCP6W	RCP6SW	Stroke (mm)	RCP6W	RCP6SW
50	○	○	300	○	○
100	○	○	350	○	○
150	○	○	400	○	○
200	○	○	450	○	○
250	○	○	500	○	○

④ Options

Name	Option Code	Reference Page
Actuator cable length 2m	Not specified	See P.197
Actuator cable length 5m	AC5	See P.197
Actuator cable length 10m	AC10	See P.197
Actuator cable length 15m	AC15	See P.197
Brake	B	See P.197
Cable exit direction (Bottom)	CJB	See P.197
Cable exit direction (Left)	CJL	See P.197
Cable exit direction (Right)	CJR	See P.197
Cable exit direction (Top)	CJT	See P.197
Flange	FL	See P.198
Non-motor end specification	NM	See P.202
T-slot nut bar (Left)	NTBL	See P.202
T-slot nut bar (Right)	NTBR	See P.202

③ Cable Length

Cable Type	Cable Code	RCP6W			RCP6SW
		P3	P5	SE	
Standard	P (1m)	○	○	○	
	S (3m)	○	○	○	
	M (5m)	○	○	○	
	X06 (6m) ~ X10 (10m)	○	○	○	
Specified length	X11 (11m) ~ X15 (15m)	○	○	○	
	X16 (16m) ~ X18 (18m)	○	○	○	
	R01 (1m) ~ R03 (3m)	○	○	○	
	R04 (4m) ~ R05 (5m)	○	○	○	
Robot cable	R06 (6m) ~ R10 (10m)	○	○	○	
	R11 (11m) ~ R15 (15m)	○	○	○	
	R16 (16m) ~ R18 (18m)	○	○	○	

* Select the length of the actuator cable and the actuator/controller connection cable so that the total is 20m or less.
* Please refer to P. 267 and 283 for more information regarding the maintenance cables.

Actuator Specifications

Item	Description
Drive system	Ball screw φ8mm, rolled C10
Positioning repeatability	±0.01mm
Lost motion	0.1mm or less
Rod	φ25mm
Rod non-rotation precision	0 degrees
Allowable load and torque on rod tip	See P. 246
Rod tip overhang distance	100mm or less
Protective structure	IP65 (IEC 60529/JIS C 0920)
Ambient operating temp. & humidity	0~40°C, 85% RH or less (Non-condensing)

CAD drawings can be downloaded from our website.
www.intelligentactuator.com



- *1 When the rod is returning to its home position, please be careful of interference from surrounding objects, as it will travel until it reaches the M.E.
- *2 If the object attached to the rod has a long overhanging length, or precise angular adjustment of the object is required, please do not use the reamed hole when the object is attached to the rod.

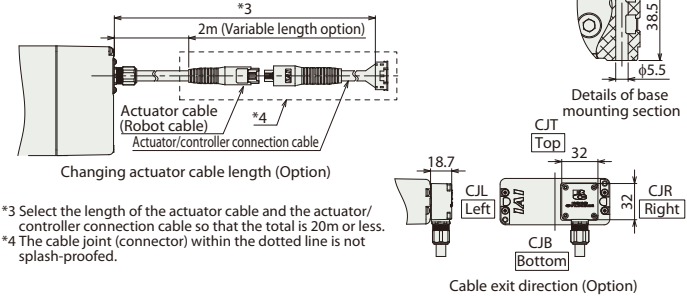
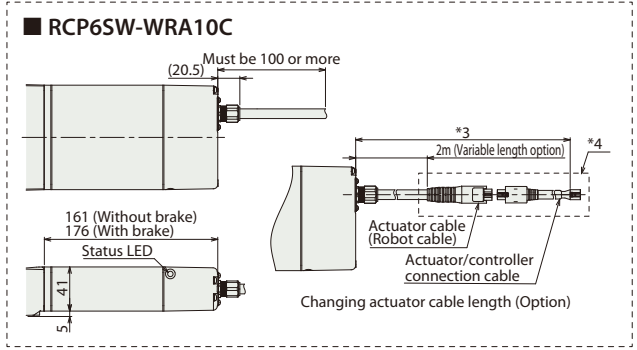
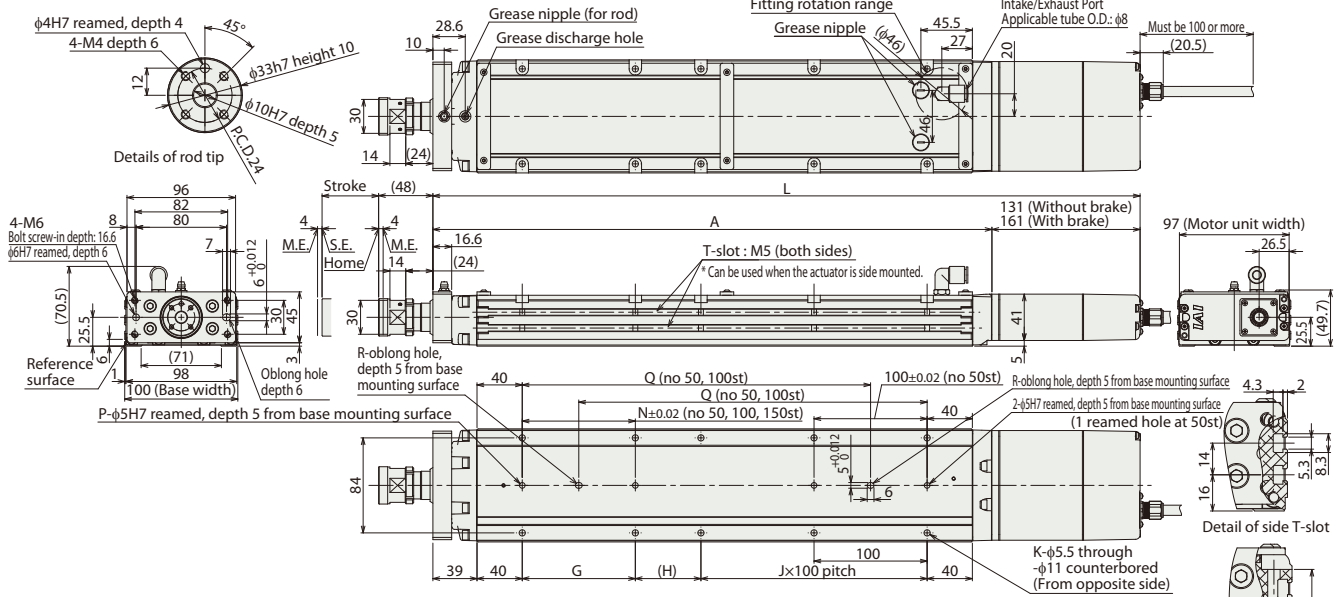

■ Rod Deflection of RCP6(S)W-WRA10C (Reference Values)

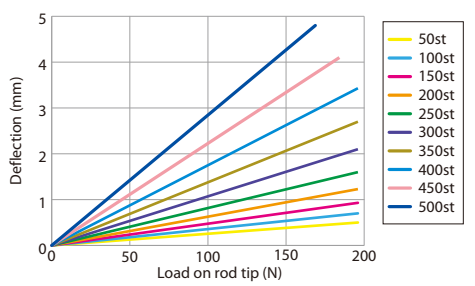

* Please refer to P.253 for more information on component materials.

■ Dimensions and Mass by Stroke

Stroke		50	100	150	200	250	300	350	400	450	500
L	RCP6W w/o brake	375.3	425.3	475.3	525.3	575.3	625.3	675.3	725.3	775.3	825.3
	RCP6W w/ brake	405.3	455.3	505.3	555.3	605.3	655.3	705.3	755.3	805.3	855.3
	RCP6SW w/o brake	405.3	455.3	505.3	555.3	605.3	655.3	705.3	755.3	805.3	855.3
	RCP6SW w/ brake	420.3	470.3	520.3	570.3	620.3	670.3	720.3	770.3	820.3	870.3
A		244.3	294.3	344.3	394.3	444.3	494.3	544.3	594.3	644.3	694.3
G		-	-	-	100	100	100	100	100	100	100
H		108	58	108	58	108	58	108	58	108	58
J		0	1	1	1	1	2	2	3	3	4
K		4	6	6	8	8	10	10	12	12	14
N		-	-	-	100	100	100	100	100	100	100
P		1	1	1	2	2	2	2	2	2	2
Q		-	-	158	208	258	308	358	408	458	508
R		0	0	1	1	1	1	1	1	1	1
3,000km	Allowable static load on rod tip (N)	196	196	196	196	196	196	196	196	184	169
	Allowable dynamic load on rod tip (N)	10	10	10	10	10	10	10	10	10	10
	Allowable dynamic load on rod tip (N) Load offset 0mm	98	98	98	95	85	76	68	62	57	52
	Allowable dynamic load on rod tip (N) Load offset 100mm	50	50	50	50	50	50	50	50	50	49
5,000km	Allowable static torque on rod tip (N·m)	5.0	5.0	5.0	5.0	5.0	5.0	5.0	5.0	5.0	4.9
	Allowable dynamic torque on rod tip (N·m) Load offset 0mm	98	98	91	80	71	63	57	52	47	43
	Allowable dynamic torque on rod tip (N·m) Load offset 100mm	50	50	50	50	50	50	50	50	48	44
	Allowable dynamic torque on rod tip (N·m)	5.0	5.0	5.0	5.0	5.0	5.0	5.0	5.0	4.8	4.4
Mass (kg)	RCP6W w/o brake	3.7	4.1	4.6	5.0	5.5	5.9	6.4	6.8	7.3	7.7
	RCP6W w/ brake	3.9	4.3	4.8	5.2	5.7	6.1	6.6	7.0	7.5	7.9
	RCP6SW w/o brake	3.8	4.2	4.7	5.1	5.6	6.0	6.5	6.9	7.4	7.8
	RCP6SW w/ brake	4.0	4.4	4.9	5.3	5.8	6.2	6.7	7.1	7.6	8.0

② Applicable Controllers

The RCP6 series actuators can be operated by the controllers indicated below. Please select the type depending on your intended use. * Please refer to P.271 for more information about the built-in controller of RCP6S series.

Name	External view	Max. number of controlled axes	Input power	Control method				Maximum number of positioning points	Reference page
				Positioner	Pulse train	Program	Network * Option		
PCON-CYB/PLB/POB		1	DC24V	●	●	-	Network cannot be selected	64	Please contact IAI for more information.
PCON-CB/CGB		1		* Option	* Option	-	DeviceNet MECHATROLINK CC-Link EtherCAT EtherNet/IP Profinet CompoNet	512 (768 for network spec.)	See P.255
MCON-C/CG		8		This model is network-compatible only.				Note: The type of compatible networks will vary depending on the controller. Please refer to reference page for more information.	256
MCON-LC/LCG		6		-	-	●	256		Please contact IAI for more information.
MSEL-PC/PG		4	Single-phase 100 ~ 230 VAC	-	-	●	30,000	Please contact IAI for more information.	
RCM-P6PC		1		Usable within the RCP6S Gateway system.				768	See P.279

* For the MCON controller, high-output enabled operation is only available if "high-output setting" is selected as an option. The maximum connectable axes with high-output enabled are C: 4 and LC: 3.

RCP6(S)W-WRA12C

Dust/Splash-Proof Spec
Battery-less Absolute
Motor Unit Type
Coupled Motor
Body Width 120 mm
24v Stepper Motor

Model Specification Items

Series	Type	Encoder Type	Motor Type	Lead	Stroke	Applicable Controller/I/O Type	Cable Length	Options
RCP6W: Separate Controller RCP6SW: Built-in Controller	WRA12C	WA	42P	12: 12mm 6: 6mm 3: 3mm	50: 50mm 500: 500mm (Every 50mm)	[RCP6W] P3: PCON MCON MSEL P5: RCM-P6PC [RCP6SW] SE: SIO Type	N: None P: 1m S: 3m M: 5m XC: Specified Length R: Robot Cable	Please refer to the options table below.

* RCP6 does not include a controller. RCP6S includes a built-in controller.
* Please refer to P.20 for more information about the model specification items.

Radial Load Applicable

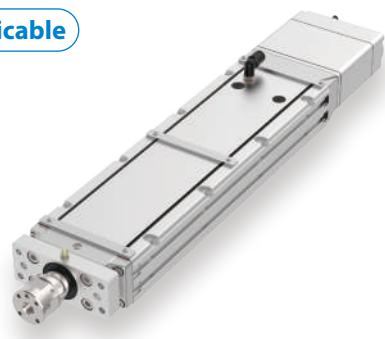
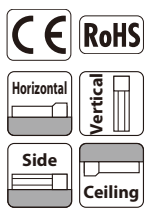

*Some limitations may apply to horizontal/side/ceiling mountings depending on the model. See page 204. Please contact IAI for more information.

- POINT Selection Notes**
- The maximum acceleration/deceleration is 1G for horizontal, and 0.5G for vertical use.
 - The actuator specifications displays the payload's maximum value, but it will vary depending on the acceleration and speed. Please refer to the "Selection Guidelines" (Tables of Payload by Speed/Acceleration) on P.239 for more details.
 - The radial cylinder is equipped with a built-in guide. Please refer to the graphs shown on P.246 and after for the allowable load mass.
 - Please refer to P.205 for performing push-motion operation.
 - Depending on the ambient operating temperature, duty control is necessary for the RCP6SW (built-in controller type) with lead 3/6. Please refer to P.247 for more information.
 - The cable joint connector is not splash-proofed, so it should be located where there is no splash.
 - The RCP6SW with built-in controller does not have a teaching tool connection port. Connect the teaching tool to the gateway unit and configure parameter data etc. via the gateway unit.

Correlation Diagrams of Speed and Payload

If the ambient temperature is 5°C or below, the speed will be lower than when it exceeds 5°C.

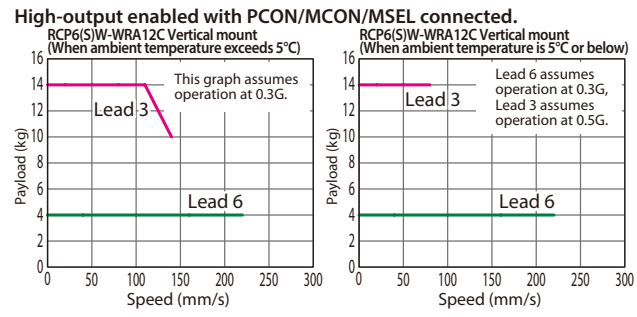
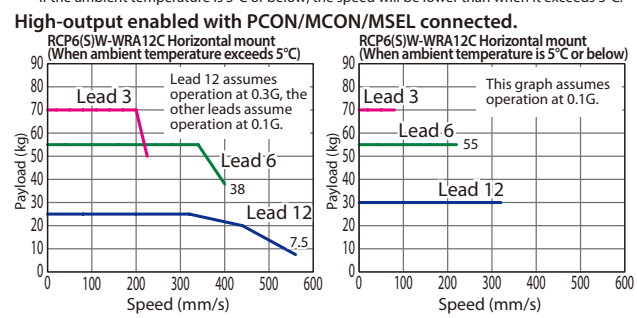

Actuator Specifications

Model Number	Lead (mm)	Max. Payload		Max. Push Force (N)**	Stroke (mm)	Stroke and Max Speed (Unit: mm/s)			
		Horizontal (kg)*	Vertical (kg)			Lead (mm)	50~400 (Every 50mm)	450	500
RCP6(S)W-WRA12C-WA-42P-12-①-②-③-④	12	30	-	93	50~500 (Every 50mm)	12	560 [320]		
RCP6(S)W-WRA12C-WA-42P-6-①-②-③-④	6	55	4	185		6	400 <<220>> [220]	375 <<220>> [220]	
RCP6(S)W-WRA12C-WA-42P-3-①-②-③-④	3	70	14	370		3	225 <<140>> [80]	220 <<140>> [80]	185 <<140>> [80]

Legend: ① Stroke ② Applicable controllers/I/O type ③ Cable length ④ Options

* Horizontal external guide rail required for horizontal payload.
** Push force only available during push mode w/ limited speed.

① Stroke

Stroke (mm)	RCP6W	RCP6SW	Stroke (mm)	RCP6W	RCP6SW
50	○	○	300	○	○
100	○	○	350	○	○
150	○	○	400	○	○
200	○	○	450	○	○
250	○	○	500	○	○

④ Options

Name	Option Code	Reference Page
Actuator cable length 2m	Not specified	See P.197
Actuator cable length 5m	AC5	See P.197
Actuator cable length 10m	AC10	See P.197
Actuator cable length 15m	AC15	See P.197
Brake	B	See P.197
Cable exit direction (Bottom)	CJB	See P.197
Cable exit direction (Left)	CJL	See P.197
Cable exit direction (Right)	CJR	See P.197
Cable exit direction (Top)	CJT	See P.197
Flange	FL	See P.198
Non-motor end specification	NM	See P.202
T-slot nut bar (Left)	NTBL	See P.202
T-slot nut bar (Right)	NTBR	See P.202

③ Cable Length

Cable Type	Cable Code	RCP6W			RCP6SW
		P3	P5	SE	
Standard	P (1m)	○	○	○	
	S (3m)	○	○	○	
	M (5m)	○	○	○	
	X06 (6m) ~ X10 (10m)	○	○	○	
Specified length	X11 (11m) ~ X15 (15m)	○	○	○	
	X16 (16m) ~ X18 (18m)	○	○	○	
	R01 (1m) ~ R03 (3m)	○	○	○	
Robot cable	R04 (4m) ~ R05 (5m)	○	○	○	
	R06 (6m) ~ R10 (10m)	○	○	○	
	R11 (11m) ~ R15 (15m)	○	○	○	
	R16 (16m) ~ R18 (18m)	○	○	○	

* Select the length of the actuator cable and the actuator/controller connection cable so that the total is 20m or less.
* Please refer to P. 267 and 283 for more information regarding the maintenance cables.

Actuator Specifications

Item	Description
Drive system	Ball screw φ10mm, rolled C10
Positioning repeatability	±0.01mm
Lost motion	0.1mm or less
Rod	φ30mm
Rod non-rotation precision	0 degrees
Allowable load and torque on rod tip	See P. 246
Rod tip overhang distance	100mm or less
Protective structure	IP65 (IEC 60529/JIS C 0920)
Ambient operating temp. & humidity	0~40°C, 85% RH or less (Non-condensing)

CAD drawings can be downloaded from our website.
www.intelligentactuator.com



- *1 When the rod is returning to its home position, please be careful of interference from surrounding objects, as it will travel until it reaches the M.E.
- *2 If the object attached to the rod has a long overhanging length, or precise angular adjustment of the object is required, please do not use the reamed hole when the object is attached to the rod.

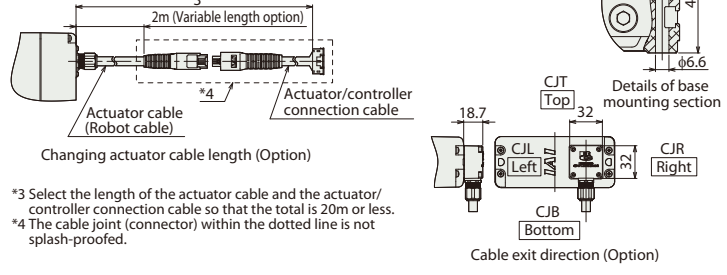
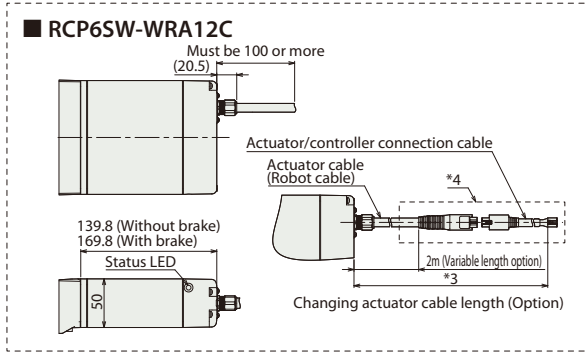
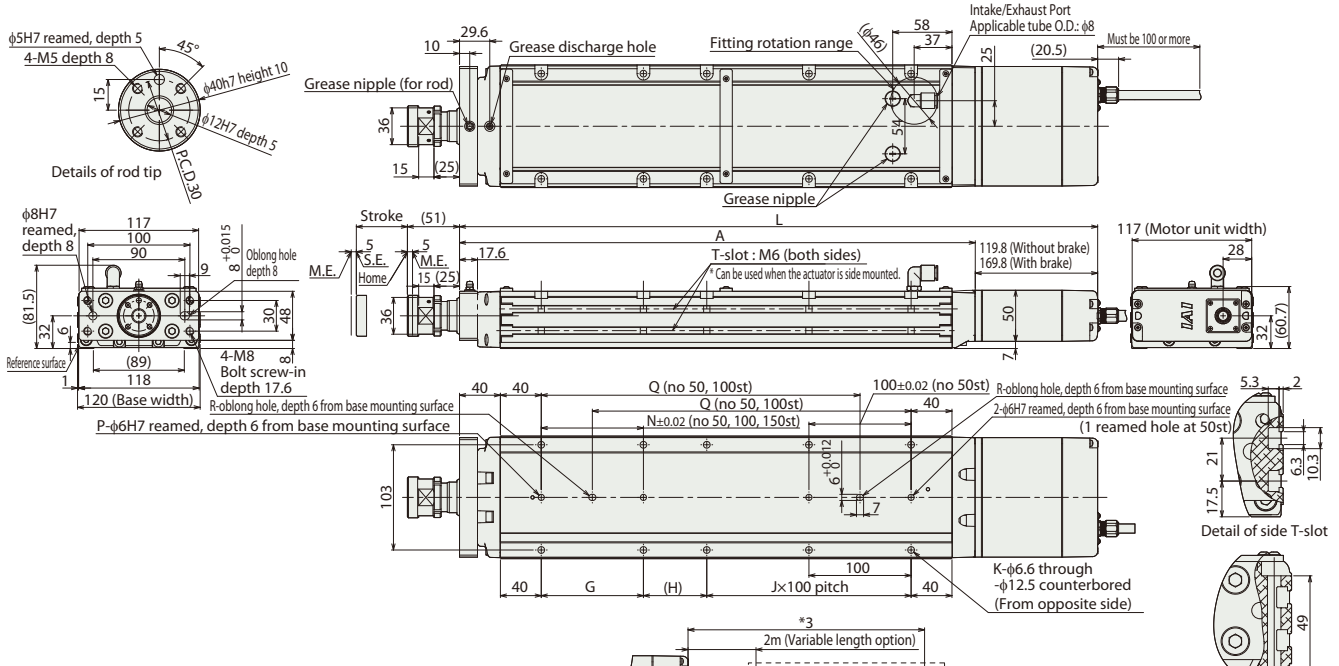

- *3 Select the length of the actuator cable and the actuator/controller connection cable so that the total is 20m or less.
- *4 The cable joint (connector) within the dotted line is not splash-proof.

■ Dimensions and Mass by Stroke

Stroke		50	100	150	200	250	300	350	400	450	500
L	RCP6W w/o brake	374.6	424.6	474.6	524.6	574.6	624.6	674.6	724.6	774.6	824.6
	RCP6W w/ brake	424.6	474.6	524.6	574.6	624.6	674.6	724.6	774.6	824.6	874.6
	RCP6SW w/o brake	394.6	444.6	494.6	544.6	594.6	644.6	694.6	744.6	794.6	844.6
	RCP6SW w/ brake	424.6	474.6	524.6	574.6	624.6	674.6	724.6	774.6	824.6	874.6
A		254.8	304.8	354.8	404.8	454.8	504.8	554.8	604.8	654.8	704.8
G		-	-	-	100	100	100	100	100	100	100
H		112	62	112	62	112	62	112	62	112	62
J		0	1	1	1	1	2	2	3	3	4
K		4	6	6	8	8	10	10	12	12	14
N		-	-	-	100	100	100	100	100	100	100
P		1	1	1	2	2	2	2	2	2	2
Q		-	-	162	212	262	312	362	412	462	512
R		0	0	1	1	1	1	1	1	1	1
3,000km	Allowable static load on rod tip (N)	294	294	294	294	294	269	241	218	198	181
	Allowable dynamic load on rod tip (N-m)	20	20	20	20	20	20	20	20	20	20
	Allowable dynamic load on rod tip (N) Load offset 0mm	147	147	137	121	107	96	87	79	72	65
5,000km	Allowable static load on rod tip (N)	100	100	100	100	99	90	82	75	68	63
	Allowable dynamic load on rod tip (N-m)	10.0	10.0	10.0	10.0	9.9	9.0	8.2	7.5	6.8	6.3
	Allowable dynamic load on rod tip (N) Load offset 0mm	147	133	115	101	90	80	72	65	59	54
Mass (kg)	RCP6W w/o brake	5.2	5.8	6.5	7.1	7.8	8.4	9.1	9.7	10.4	11.0
	RCP6W w/ brake	5.5	6.1	6.8	7.4	8.1	8.7	9.4	10.0	10.7	11.3
	RCP6SW w/o brake	5.3	5.9	6.6	7.2	7.9	8.5	9.2	9.8	10.5	11.1
	RCP6SW w/ brake	5.6	6.2	6.9	7.5	8.2	8.8	9.5	10.1	10.8	11.4

■ Rod Deflection of RCP6(S)W-WRA12C (Reference Values)

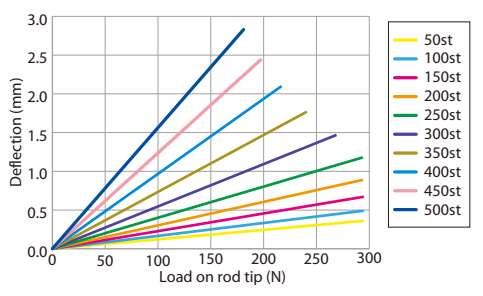

* Please refer to P.254 for more information on component materials.

② Applicable Controllers

The RCP6 series actuators can be operated by the controllers indicated below. Please select the type depending on your intended use. * Please refer to P.271 for more information about the built-in controller of RCP6S series.

Name	External view	Max. number of controlled axes	Input power	Control method				Maximum number of positioning points	Reference page
				Positioner	Pulse train	Program	Network * Option		
PCON-CYB/PLB/POB		1	DC24V	●	●	-	Network cannot be selected	64	Please contact IAI for more information.
PCON-CB/CGB		1		* Option	●	-	DeviceNet MECHATROLINK CC-Link EtherCAT EtherNet/IP CANopen CompoNet	512 (768 for network spec.)	See P.255
MCON-C/CG		8		* Option	●	-		This model is network-compatible only.	256
MCON-LC/LCG		6		-	-	●	Note: The type of compatible networks will vary depending on the controller. Please refer to reference page for more information.	256	Please contact IAI for more information.
MSEL-PC/PG		4	Single-phase 100 ~ 230 VAC	-	-	●		30,000	Please contact IAI for more information.
RCM-P6PC		1		Usable within the RCP6S Gateway system.				768	See P.279

* For the MCON controller, high-output enabled operation is only available if "high-output setting" is selected as an option. The maximum connectable axes with high-output enabled are C: 4 and LC: 3.

Foreword
Slider Type
Wide Slider Type
Rod Type
Radial Cylinder
Wide Radial Cylinder
Table Type
Cleanroom Slider
Cleanroom Wide Slider
Dust/Splash-Proof Rod
Dust/Splash-Proof Radial Cylinder
Dust/Splash-Proof Wide Radial Cylinder
Options
Reference Data
Controller

RCP6(S)W-WRA14C

Dust/Splash-Proof Spec
Battery-less Absolute
Motor Unit Type
Coupled Motor
Body Width 140 mm
24v Stepper Motor

Model Specification Items

Series	Type	Encoder Type	Motor Type	Lead	Stroke	Applicable Controller/I/O Type	Cable Length	Options
RCP6W: Separate Controller RCP6SW: Built-in Controller	WRA14C	WA	56P	16 : 16mm 8 : 8mm 4 : 4mm	50:50mm 600:600mm (Every 50mm)	[RCP6W] P3 : PCON MCON MSEL P5 : RCM-P6PC [RCP6SW] SE: SIO Type	N : None P : 1m S : 3m M : 5m XC□ : Specified Length R□ : Robot Cable	Please refer to the options table below.

* RCP6 does not include a controller. RCP6S includes a built-in controller.
 * Please refer to P.20 for more information about the model specification items.

Radial Load Applicable

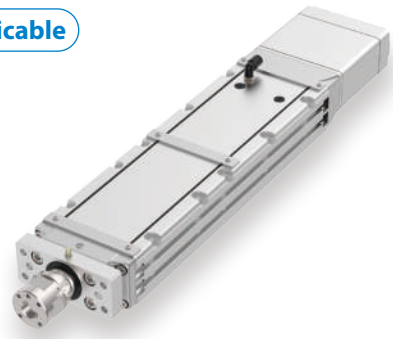
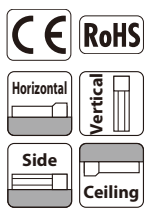

*Some limitations may apply to horizontal/side/ceiling mountings depending on the model. See page 204. Please contact IAI for more information.

- POINT Selection Notes**
- The maximum acceleration/deceleration is 1G for horizontal, and 0.5G for vertical use.
 - The actuator specifications displays the payload's maximum value, but it will vary depending on the acceleration and speed. Please refer to the "Selection Guidelines" (Tables of Payload by Speed/Acceleration) on P.240 for more details.
 - The radial cylinder is equipped with a built-in guide. Please refer to the graphs shown on P.246 and after for the allowable load mass.
 - Please refer to P.205 for performing push-motion operation.
 - Depending on the ambient operating temperature, duty control is necessary for the RCP6SW (built-in controller type) with lead 4/8/16. Please refer to P.247 for more information.
 - The cable joint connector is not splash-proofed, so it should be located where there is no splash.
 - The RCP6SW with built-in controller does not have a teaching tool connection port. Connect the teaching tool to the gateway unit and configure parameter data etc. via the gateway unit.

Correlation Diagrams of Speed and Payload

If the ambient temperature is 5°C or below, the speed will be lower than when it exceeds 5°C.

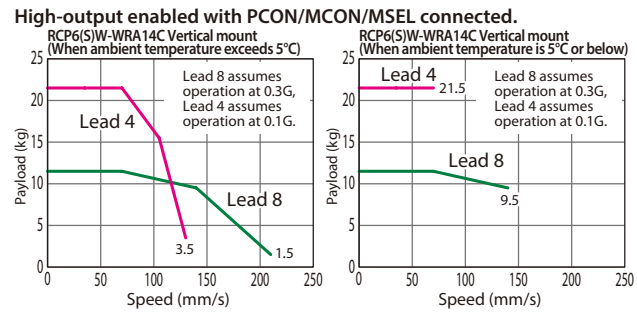
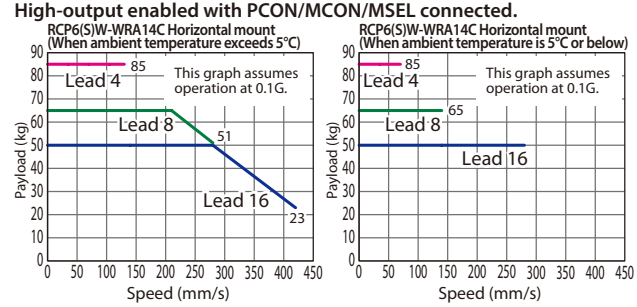

Actuator Specifications

* Horizontal external guide rail required for horizontal payload.
 ** Push force only available during push mode w / limited speed.

Model Number	Lead (mm)	Max. Payload		Max. Push Force (N)**	Stroke (mm)	Stroke and Max Speed (Unit: mm/s)	
		Horizontal (kg)*	Vertical (kg)			Lead (mm)	50~600 (Every 50mm)
RCP6(S)W-WRA14C-WA-56P-16-①-②-③-④	16	50	-	273	50~600 (Every 50mm)	16	420 [280]
RCP6(S)W-WRA14C-WA-56P-8-①-②-③-④	8	65	11.5	547		8	280 <210> [140]
RCP6(S)W-WRA14C-WA-56P-4-①-②-③-④	4	85	21.5	1,094		4	130 [70]

Legend: ① Stroke ② Applicable controllers/I/O type ③ Cable length ④ Options

Values in brackets <> are for vertical use.
 Values in brackets [] are when ambient temperature is 5°C or below.

① Stroke

Stroke (mm)	RCP6W	RCP6SW	Stroke (mm)	RCP6W	RCP6SW
50	○	○	350	○	○
100	○	○	400	○	○
150	○	○	450	○	○
200	○	○	500	○	○
250	○	○	550	○	○
300	○	○	600	○	○

④ Options

Name	Option Code	Reference Page
Actuator cable length 2m	Not specified	See P.197
Actuator cable length 5m	AC5	See P.197
Actuator cable length 10m	AC10	See P.197
Actuator cable length 15m	AC15	See P.197
Brake	B	See P.197
Cable exit direction (Bottom)	CJB	See P.197
Cable exit direction (Left)	CJL	See P.197
Cable exit direction (Right)	CJR	See P.197
Cable exit direction (Top)	CJT	See P.197
Flange	FL	See P.198
Non-motor end specification	NM	See P.202
T-slot nut bar (Left)	NTBL	See P.202
T-slot nut bar (Right)	NTBR	See P.202

③ Cable Length

Cable Type	Cable Code	RCP6W			RCP6SW
		P3	P5	SE	
Standard	P(1m)	○	○	○	
	S(3m)	○	○	○	
	M(5m)	○	○	○	
	X06(6m)~X10(10m)	○	○	○	
Specified length	X11(11m)~X15(15m)	○	○	○	
	X16(16m)~X18(18m)	○	○	○	
	R01(1m)~R03(3m)	○	○	○	
Robot cable	R04(4m)~R05(5m)	○	○	○	
	R06(6m)~R10(10m)	○	○	○	
	R11(11m)~R15(15m)	○	○	○	
	R16(16m)~R18(18m)	○	○	○	

* Select the length of the actuator cable and the actuator/controller connection cable so that the total is 20m or less.
 * Please refer to P. 267 and 283 for more information regarding the maintenance cables.

Actuator Specifications

Item	Description
Drive system	Ball screw φ12mm, rolled C10
Positioning repeatability	±0.01mm
Lost motion	0.1mm or less
Rod	φ40mm
Rod non-rotation precision	0 degrees
Allowable load and torque on rod tip	See P. 246
Rod tip overhang distance	150mm or less
Protective structure	IP65 (IEC 60529/JIS C 0920)
Ambient operating temp. & humidity	0~40°C, 85% RH or less (Non-condensing)

CAD drawings can be downloaded from our website.
www.intelligentactuator.com



*1 When the rod is returning to its home position, please be careful of interference from surrounding objects, as it will travel until it reaches the M.E.
M.E: Mechanical end S.E: Stroke end
*2 If the object attached to the rod has a long overhang length, or precise angular adjustment of the object is required, please do not use the reamed hole when the object is attached to the rod.

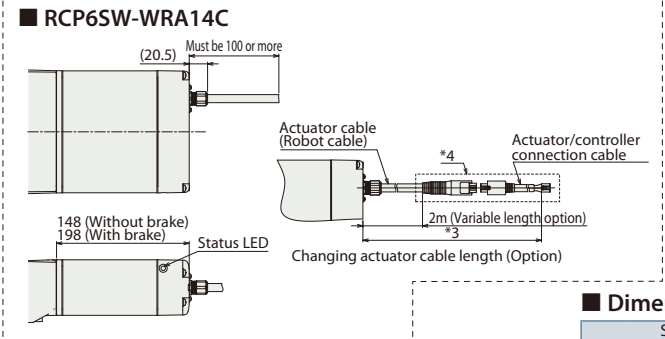
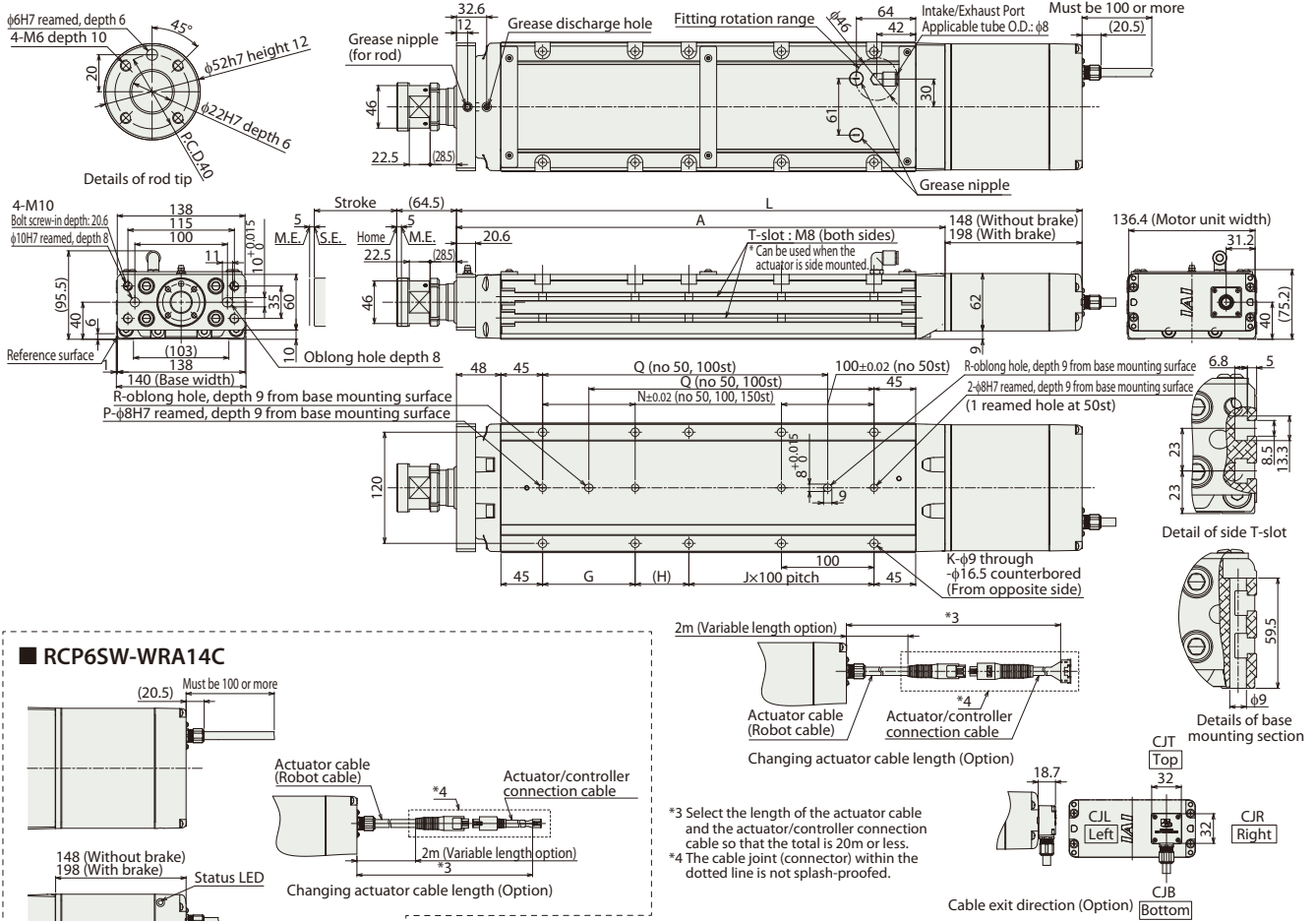

■ Dimensions and Mass by Stroke

Stroke	Stroke												
	50	100	150	200	250	300	350	400	450	500	550	600	
L	w/o brake	425.8	475.8	525.8	575.8	625.8	675.8	725.8	775.8	825.8	875.8	925.8	975.8
	w/ brake	475.8	525.8	575.8	625.8	675.8	725.8	775.8	825.8	875.8	925.8	975.8	1,025.8
A		277.8	327.8	377.8	427.8	477.8	527.8	577.8	627.8	677.8	727.8	777.8	827.8
G		-	-	-	100	100	100	100	100	100	100	100	100
H		108	58	108	58	108	58	108	58	108	58	108	58
J		0	1	1	1	2	2	3	3	4	4	5	5
K		4	6	6	8	8	10	10	12	12	14	14	16
N		-	-	-	100	100	100	100	100	100	100	100	100
P		1	1	1	2	2	2	2	2	2	2	2	2
Q		-	-	158	208	258	308	358	408	458	508	558	608
R		0	0	1	1	1	1	1	1	1	1	1	1
Allowable static torque on rod tip (N)		454	392	345	307	276	251	229	210	193	179	166	154
		30	30	30	30	30	30	30	30	30	30	30	30
	3,000km	199	170	148	131	117	104	94	85	77	70	64	58
	5,000km	100	100	100	100	100	95	87	79	72	66	60	55
Allowable dynamic torque on rod tip (N-m)		15.0	15.0	15.0	15.0	15.0	14.3	13.0	11.8	10.8	9.9	9.0	8.2
		167	143	124	109	97	87	78	70	63	57	51	46
	3,000km	100	100	100	96	87	79	71	65	59	53	48	44
	5,000km	15.0	15.0	15.0	14.4	13.0	11.8	10.7	9.7	8.8	8.0	7.3	6.6
Mass (kg)		8.9	9.7	10.6	11.5	12.4	13.3	14.2	15.1	16.0	16.9	17.8	18.7
	RCP6W	9.4	10.2	11.1	12.0	12.9	13.8	14.7	15.6	16.5	17.4	18.3	19.2
	RCP6SW	9.0	9.8	10.7	11.6	12.5	13.4	14.3	15.2	16.1	17.0	17.9	18.8
		9.4	10.2	11.1	12.0	12.9	13.8	14.7	15.6	16.5	17.4	18.3	19.2

■ Rod Deflection of RCP6(S)W-WRA14C (Reference Values)

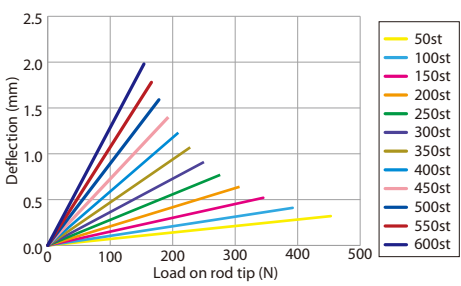

* Please refer to P.254 for more information on component materials.

② Applicable Controllers

The RCP6 series actuators can be operated by the controllers indicated below. Please select the type depending on your intended use. * Please refer to P.271 for more information about the built-in controller of RCP6S series.

Name	External view	Max. number of controlled axes	Input power	Control method				Maximum number of positioning points	Reference page
				Positioner	Pulse train	Program	Network * Option		
PCON-CYB/PLB/POB		1	DC24V	●	●	-	Network cannot be selected	64	Please contact IAI for more information.
PCON-CB/CGB		1		* Option	* Option	-	DeviceNet MECHATROLINK CC-Link EtherCAT EtherNet/IP CANopen CompoNet	512 (768 for network spec.)	See P.255
MCON-C/CG		8		This model is network-compatible only.				Note: The type of compatible networks will vary depending on the controller. Please refer to reference page for more information.	256
MCON-LC/LCG		6		-	-	●	256		Please contact IAI for more information.
MSEL-PC/PG		4	Single-phase 100 ~ 230 VAC	-	-	●	30,000	Please contact IAI for more information.	
RCM-P6PC		1		Usable within the RCP6S Gateway system.				768	See P.279

* For the MCON controller, high-output enabled operation is only available if "high-output setting" is selected as an option. The maximum connectable axes with high-output enabled are C: 4 and LC: 3.

RCP6(S)W-WRA16C

Dust/Splash-Proof Spec | Battery-less Absolute | Motor Unit Type | Coupled Motor | Body Width 160 mm | 24v Stepper Motor

Model Specification Items

Series: **WRA16C** | Type: **WA** | Encoder Type: **60P** | Motor Type: | Lead: | Stroke: | Applicable Controller/I/O Type: | Cable Length: | Options:

RCP6W: Separate Controller
RCP6SW: Built-in Controller

WA: Battery-less Absolute
60P: Stepper Motor 60□ Size

20 :20mm
10 :10mm
5 : 5mm

50:50mm
800:800mm (Every 50mm)

[RCP6W]
P4 : PCON-CFB/CGFB
[RCP6SW]
SE: SIO Type

N : None
P : 1m
S : 3m
M : 5m
X□ : Specified Length
R□ : Robot Cable

Please refer to the options table below.

* RCP6 does not include a controller. RCP6S includes a built-in controller.
* Please refer to P.20 for more information about the model specification items.

Radial Load Applicable

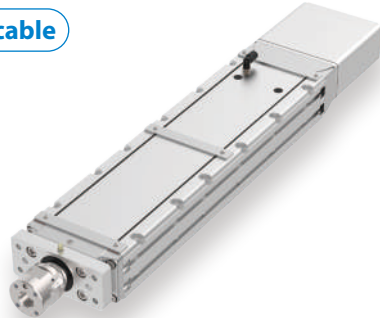
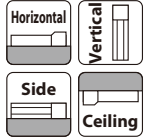

*Some limitations may apply to horizontal/side/ceiling mountings depending on the model. See page 204. Please contact IAI for more information.



- The maximum acceleration/deceleration is 0.1G for lead 5 and 0.2G for lead 10/20.
- The actuator specifications displays the payload's maximum value, but it will vary depending on the acceleration and speed. Please refer to the "Selection Guidelines" (Tables of Payload by Speed/Acceleration) on P.240 for more details.
- The radial cylinder is equipped with a built-in guide. Please refer to the graphs shown on P.246 and after for the allowable load mass.
- Please refer to P.205 for performing push-motion operation.
- For RCP6SW (built-in controller type), please limit the duty cycle to 70% or less.
- The service life of an actuator with lead 5 varies depending on the payload when using vertically. Please refer to P. 206 for more information.
- The cable joint connector is not splash-proofed, so it should be located where there is no splash.
- The RCP6SW with built-in controller does not have a teaching tool connection port. Connect the teaching tool to the gateway unit and configure parameter data etc. via the gateway unit.

Correlation Diagrams of Speed and Payload

If the ambient temperature is 5°C or below, the speed will be lower than when it exceeds 5°C.

PCON connected.

RCP6(S)W-WRA16C Horizontal mount (When ambient temperature exceeds 5°C)

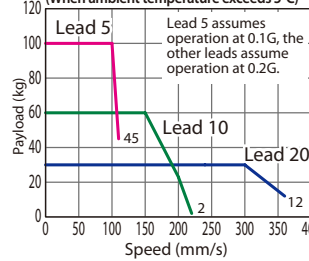

RCP6(S)W-WRA16C Horizontal mount (When ambient temperature is 5°C or below)

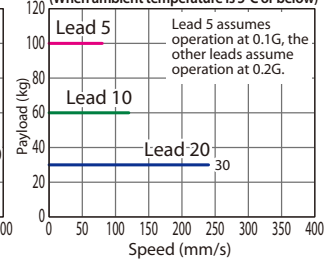

PCON connected.

RCP6(S)W-WRA16C Vertical mount (When ambient temperature exceeds 5°C)

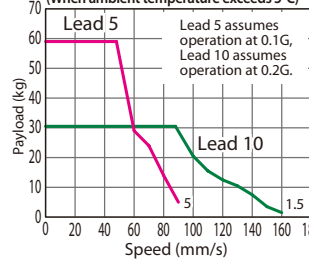

RCP6(S)W-WRA16C Vertical mount (When ambient temperature is 5°C or below)

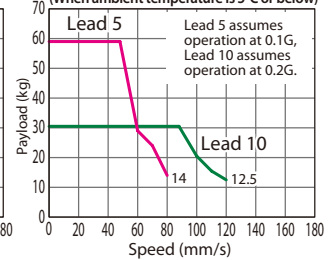

Actuator Specifications

Lead and Payload

* Horizontal external guide rail required for horizontal payload.
** Push force only available during push mode w / limited speed.

Model Number	Lead (mm)	Max. Payload		Max. Push Force (N)**	Stroke (mm)
		Horizontal (kg)*	Vertical (kg)		
RCP6(S)W-WRA16C-WA-60P-20-①-②-③-④	20	30	-	500	50~800 (Every 50mm)
RCP6(S)W-WRA16C-WA-60P-10-①-②-③-④	10	60	30.5	1,000	
RCP6(S)W-WRA16C-WA-60P-5-①-②-③-④	5	100	59	2,000	

Legend: ① Stroke ② Applicable controllers/I/O type ③ Cable length ④ Options

Stroke and Max Speed

(Unit: mm/s)

Lead (mm)	100~450 (Every 50mm)							
	50	100	150	200	250	300	350	400
20	280 [240]	360 [240]	340 [240]	295 [240]	260 [240]	225 [225]	200 [200]	180 [180]
10	220 <160> [120]	195 <160> [120]	165 <160> [120]	145 [120]	125 [120]	110 [110]	100 [100]	90 [90]
5	110 <90> [80]	95 <90> [80]	80 [80]	70 [70]	60 [60]	55 [55]	50 [50]	45 [45]

Values in brackets < > are for vertical use.
Values in brackets [] are when ambient temperature is 5°C or below.

① Stroke

Stroke (mm)	RCP6W	RCP6SW	Stroke (mm)	RCP6W	RCP6SW
50	○	○	450	○	○
100	○	○	500	○	○
150	○	○	550	○	○
200	○	○	600	○	○
250	○	○	650	○	○
300	○	○	700	○	○
350	○	○	750	○	○
400	○	○	800	○	○

③ Cable Length

Cable Type	Cable Code	RCP6W	RCP6SW
Standard	P(1m)	○	○
	S(3m)	○	○
	M(5m)	○	○
Specified length	X06 (6m) ~X10 (10m)	○	○
	X11 (11m) ~X15 (15m)	○	○
	X16 (16m) ~X18 (18m)	○	○
Robot cable	R01 (1m) ~R03 (3m)	○	○
	R04 (4m) ~R05 (5m)	○	○
	R06 (6m) ~R10 (10m)	○	○
	R11 (11m) ~R15 (15m)	○	○
	R16 (16m) ~R18 (18m)	○	○

* Select the length of the actuator cable and the actuator/controller connection cable so that the total is 20m or less.

* Please refer to P. 267 and 283 for more information regarding the maintenance cables.

④ Options

Name	Option Code	Reference Page
Actuator cable length 2m	Not specified	See P.197
Actuator cable length 5m	AC5	See P.197
Actuator cable length 10m	AC10	See P.197
Actuator cable length 15m	AC15	See P.197
Brake	B	See P.197
Cable exit direction (Bottom)	CJB	See P.197
Cable exit direction (Left)	CJL	See P.197
Cable exit direction (Right)	CJR	See P.197
Cable exit direction (Top)	CJT	See P.197
Flange	FL	See P.198
Non-motor end specification	NM	See P.202
T-slot nut bar (Left)	NTBL	See P.202
T-slot nut bar (Right)	NTBR	See P.202

Actuator Specifications

Item	Description
Drive system	Ball screw φ16mm, rolled C10
Positioning repeatability	±0.01mm
Lost motion	0.1mm or less
Rod	φ45mm
Rod non-rotation precision	0 degrees
Allowable load and torque on rod tip	See P. 246
Rod tip overhang distance	150mm or less
Protective structure	IP65 (IEC 60529/JIS C 0920)
Ambient operating temp. & humidity	0~40°C, 85% RH or less (Non-condensing)

CAD drawings can be downloaded from our website.
www.intelligentactuator.com



*1 When the rod is returning to its home position, please be careful of interference from surrounding objects, as it will travel until it reaches the M.E.
M.E: Mechanical end S.E: Stroke end

*2 If the object attached to the rod has a long overhang length, or precise angular adjustment of the object is required, please do not use the reamed hole when the object is attached to the rod.

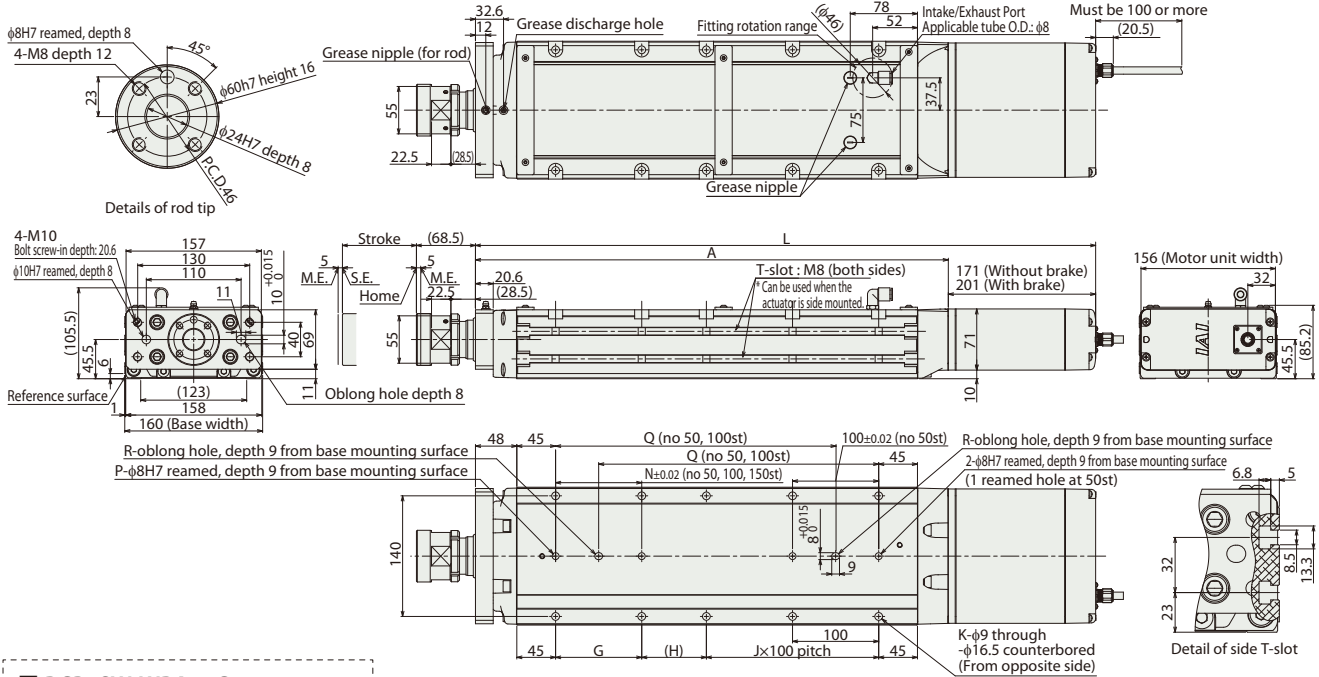

RCP6SW-WRA16C

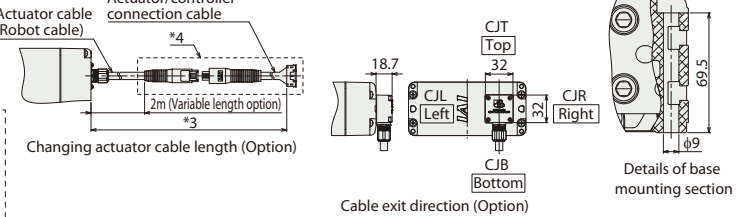
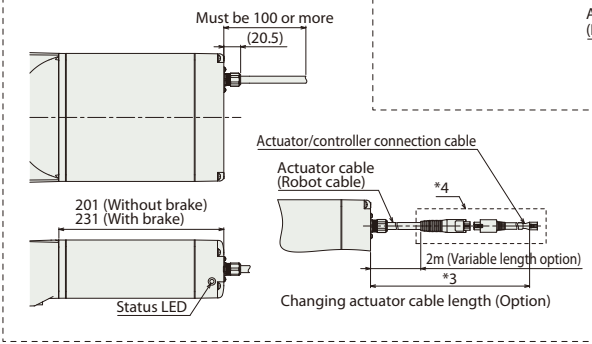

*3 Select the length of the actuator cable and the actuator/controller connection cable so that the total is 20m or less.
*4 The cable joint (connector) within the dotted line is not splash-proofed.

Rod Deflection of RCP6(S) W-WRA16C (Reference Values)

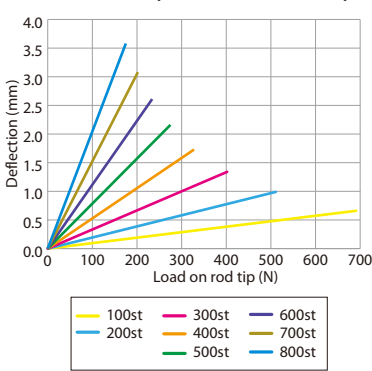

Dimensions and Mass by Stroke

L	Stroke	Stroke															
		50	100	150	200	250	300	350	400	450	500	550	600	650	700	750	800
RCP6W	w/o brake	469.8	519.8	569.8	619.8	669.8	719.8	769.8	819.8	869.8	919.8	969.8	1,019.8	1,069.8	1,119.8	1,169.8	1,219.8
	w/ brake	499.8	549.8	599.8	649.8	699.8	749.8	799.8	849.8	899.8	949.8	999.8	1,049.8	1,099.8	1,149.8	1,199.8	1,249.8
RCP6SW	w/o brake	499.8	549.8	599.8	649.8	699.8	749.8	799.8	849.8	899.8	949.8	999.8	1,049.8	1,099.8	1,149.8	1,199.8	1,249.8
	w/ brake	529.8	579.8	629.8	679.8	729.8	779.8	829.8	879.8	929.8	979.8	1,029.8	1,079.8	1,129.8	1,179.8	1,229.8	1,279.8
A		298.8	348.8	398.8	448.8	498.8	548.8	598.8	648.8	698.8	748.8	798.8	848.8	898.8	948.8	998.8	1,048.8
G		-	-	100	100	100	100	100	100	100	100	100	100	100	100	100	100
H		125	75	125	75	125	75	125	75	125	75	125	75	125	75	125	75
J		0	1	1	1	1	2	2	3	3	4	4	5	5	6	6	7
K		4	6	6	8	8	10	10	12	12	14	14	16	16	18	18	20
N		-	-	-	100	100	100	100	100	100	100	100	100	100	100	100	100
P		1	1	1	2	2	2	2	2	2	2	2	2	2	2	2	2
Q		-	-	175	225	275	325	375	425	475	525	575	625	675	725	775	825
R		0	0	1	1	1	1	1	1	1	1	1	1	1	1	1	1
Allowable static load on rod tip (N)		588	588	588	511	451	402	362	329	300	275	254	235	217	202	188	176
	Allowable static torque on rod tip (N·m)	40	40	40	40	40	40	40	40	40	40	40	40	40	40	40	40
3,000km	Allowable dynamic load on rod tip (N)	255	220	191	168	149	134	120	109	99	90	81	74	67	61	55	50
	Load offset 0mm	133	133	133	133	133	122	111	101	92	84	77	70	64	58	53	48
5,000km	Allowable dynamic load on rod tip (N)	20.0	20.0	20.0	20.0	20.0	18.3	16.7	15.2	13.8	12.6	11.5	10.5	9.6	8.7	7.9	7.1
	Load offset 0mm	214	184	160	140	124	111	99	89	80	72	65	59	53	47	42	37
Mass (kg)	RCP6W w/o brake	12.4	13.6	14.8	15.9	17.0	18.2	19.3	20.5	21.6	22.8	23.9	25.1	26.2	27.4	28.5	29.7
	RCP6SW w/o brake	12.9	14.1	15.3	16.4	17.5	18.7	19.8	21.0	22.1	23.3	24.4	25.6	26.7	27.9	29.0	30.2
	RCP6W w/ brake	12.5	13.7	14.9	16.0	17.1	18.3	19.4	20.6	21.7	22.9	24.0	25.2	26.3	27.5	28.6	29.8
	RCP6SW w/ brake	13.0	14.2	15.4	16.5	17.6	18.8	19.9	21.1	22.2	23.4	24.5	25.7	26.8	28.0	29.1	30.3

* Please refer to P.254 for more information on component materials.

② Applicable Controllers

The RCP6 series actuators can be operated by the controllers indicated below. Please select the type depending on your intended use. * Please refer to P.271 for more information about the built-in controller of RCP6 series.

Name	External view	Max. number of controlled axes	Input power	Control method			Maximum number of positioning points	Reference page
				Positioner	Pulse train	Program		
PCON-CFB/CGFB		1	DC24V	●	●	-	512 (768 for network spec.)	See P.255
				*Option	*Option			
Control method Network * Option DeviceNet CompoNet EtherNet/IP 								

RCP6(S)W-WRA10R

Dust/Splash-Proof Spec | Battery-less Absolute | Motor Unit Type | Side-mounted Motor | Body Width 100* mm | 24v Stepper Motor

Model Specification Items	Series	WRA10R	Encoder Type	WA	Motor Type	35P	Lead	Stroke	Applicable Controller/I/O Type	Cable Length	Options
	RCP6W: Separate Controller RCP6SW: Built-in Controller		WA: Battery-less Absolute	35P: Stepper Motor 35□ Size	10 : 10mm 5 : 5mm 2.5 : 2.5mm	50:50mm 500:500mm (Every 50mm)	[RCP6W] P3 : PCON MCON MSEL P5 : RCM-P6PC [RCP6SW] SE: SIO Type	N : None P : 1m S : 3m M : 5m XC□ : Specified Length R□ : Robot Cable		Please refer to the options table below. * Please make sure to specify either ML or MR when ordering the side-mounted motor type.	

* RCP6 does not include a controller. RCP6S includes a built-in controller.
* Please refer to P.20 for more information about the model specification items.

Radial Load Applicable

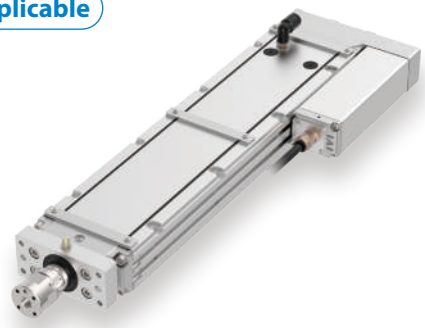
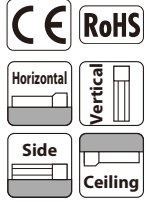

The figure above is the motor side-mounted to left (ML).

*Some limitations may apply to horizontal/side/ceiling mountings depending on the model. See page 204. Please contact IAI for more information.

- POINT Selection Notes**
- (1) The maximum acceleration/deceleration is 1G for horizontal, and 0.5G for vertical use.
 - (2) The actuator specifications displays the payload's maximum value, but it will vary depending on the acceleration and speed. Please refer to the "Selection Guidelines" (Tables of Payload by Speed/Acceleration) on P.241 for more details.
 - (3) The radial cylinder is equipped with a built-in guide. Please refer to the graphs shown on P.246 and after for the allowable load mass.
 - (4) Please refer to P.205 for performing push-motion operation.
 - (5) The cable joint connector is not splash-proofed, so it should be located where there is no splash.
 - (6) The RCP6SW with built-in controller does not have a teaching tool connection port. Connect the teaching tool to the gateway unit and configure parameter data etc. via the gateway unit.

Correlation Diagrams of Speed and Payload

If the ambient temperature is 5°C or below, the speed will be lower than when it exceeds 5°C.

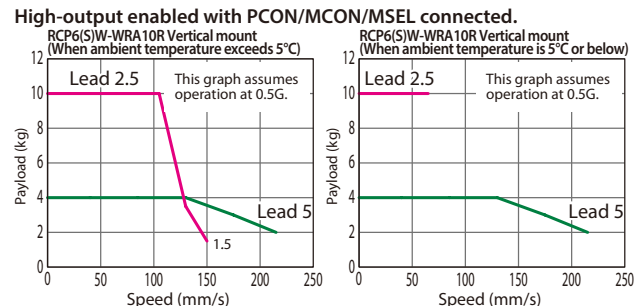
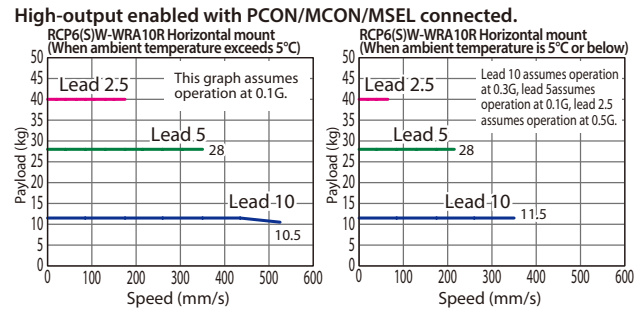

Actuator Specifications

Lead and Payload

Model Number	Lead (mm)	Max. Payload		Max. Push Force (N)**	Stroke (mm)
		Horizontal (kg)*	Vertical (kg)		
RCP6(S)W-WRA10R-WA-35P-10-①-②-③-④	10	11.5	-	77	50~500 (Every 50mm)
RCP6(S)W-WRA10R-WA-35P-5-①-②-③-④	5	28	4	155	
RCP6(S)W-WRA10R-WA-35P-2.5-①-②-③-④	2.5	40	10	310	

Legend: ① Stroke ② Applicable controllers/I/O type ③ Cable length ④ Options

Stroke and Max Speed (Unit: mm/s)

Lead (mm)	50~400 (Every 50mm)	450	500
10	525 [350]	490 [350]	
5	350 <[215]> [215]	290 <[215]> [215]	240 <[215]> [215]
2.5	175 <[150]> [65]	145 [65]	120 [65]

Values in brackets < > are for vertical use.
Values in brackets [] are when ambient temperature is 5°C or below.

① Stroke

Stroke (mm)	RCP6W	RCP6SW	Stroke (mm)	RCP6W	RCP6SW
50	○	○	300	○	○
100	○	○	350	○	○
150	○	○	400	○	○
200	○	○	450	○	○
250	○	○	500	○	○

④ Options

Name	Option Code	Reference Page
Actuator cable length 2m	Not specified	See P.197
Actuator cable length 5m	AC5	See P.197
Actuator cable length 10m	AC10	See P.197
Actuator cable length 15m	AC15	See P.197
Brake	B	See P.197
Cable exit direction (Bottom)	CJB	See P.197
Cable exit direction (Outside)	CJO	See P.197
Cable exit direction (Top)	CJT	See P.197
Flange	FL	See P.198
Motor side-mounted to left (standard)	ML	See P.201
Motor side-mounted to right	MR	See P.201
Non-motor end specification	NM	See P.202
T-slot nut bar (Left)	NTBL	See P.202
T-slot nut bar (Right)	NTBR	See P.202

* Be sure to confirm with the "Selection Notes (P.204)" when selecting options.

③ Cable Length

Cable Type	Cable Code	RCP6W			RCP6SW
		P3	P5	SE	
Standard	P (1m)	○	○	○	
	S (3m)	○	○	○	
	M (5m)	○	○	○	
	X06 (6m)~ X10 (10m)	○	○	○	
Specified length	X11 (11m)~ X15 (15m)	○	○	○	
	X16 (16m)~ X18 (18m)	○	○	○	
	R01 (1m)~ R03 (3m)	○	○	○	
Robot cable	R04 (4m)~ R05 (5m)	○	○	○	
	R06 (6m)~ R10 (10m)	○	○	○	
	R11 (11m)~ R15 (15m)	○	○	○	
	R16 (16m)~ R18 (18m)	○	○	○	

* Select the length of the actuator cable and the actuator/controller connection cable so that the total is 20m or less.
* Please refer to P. 267 and 283 for more information regarding the maintenance cables.

Actuator Specifications

Item	Description
Drive system	Ball screw φ8mm, rolled C10
Positioning repeatability	±0.01mm
Lost motion	0.1mm or less
Rod	φ25mm
Rod non-rotation precision	0 degrees
Allowable load and torque on rod tip	See P. 246
Rod tip overhang distance	100mm or less
Protective structure	IP65 (IEC 60529/JIS C 0920)
Ambient operating temp. & humidity	0~40°C, 85% RH or less (Non-condensing)

CAD drawings can be downloaded from our website.
www.intelligentactuator.com



*1 When the rod is returning to its home position, please be careful of interference from surrounding objects, as it will travel until it reaches the M.E.
M.E: Mechanical end S.E: Stroke end
*2 If the object attached to the rod has a long overhang length, or precise angular adjustment of the object is required, please do not use the reamed hole when the object is attached to the rod.

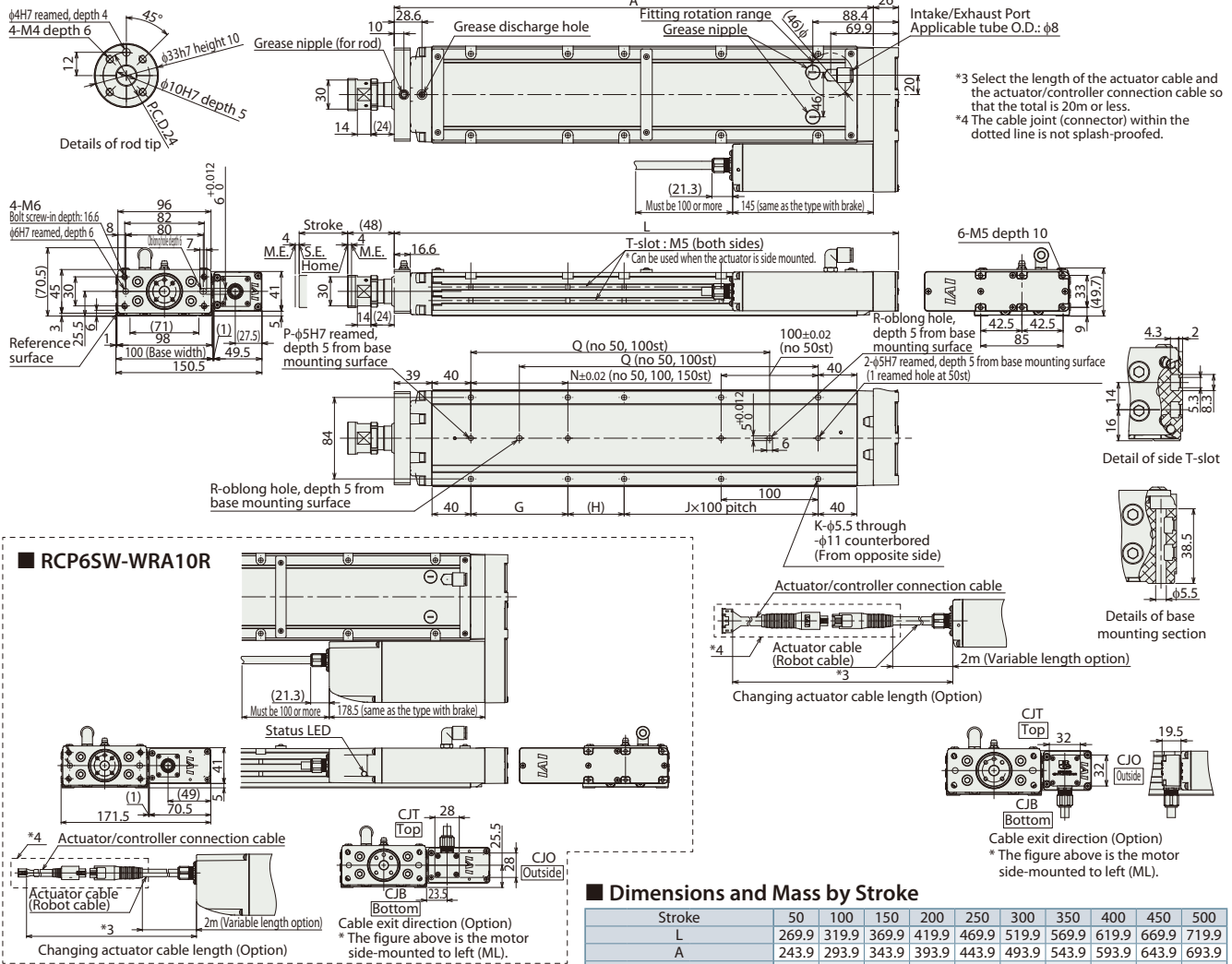

■ Rod Deflection of RCP6(S)W-WRA10R (Reference Values)

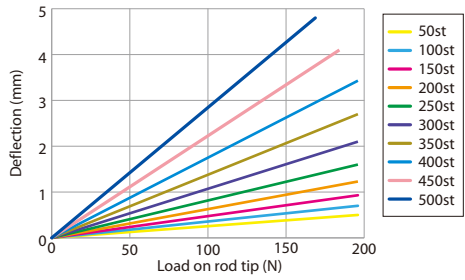

* Please refer to P.253 for more information on component materials.

■ Dimensions and Mass by Stroke

Stroke	50	100	150	200	250	300	350	400	450	500	
L	269.9	319.9	369.9	419.9	469.9	519.9	569.9	619.9	669.9	719.9	
A	243.9	293.9	343.9	393.9	443.9	493.9	543.9	593.9	643.9	693.9	
G	-	-	-	100	100	100	100	100	100	100	
H	108	58	108	58	108	58	108	58	108	58	
J	0	1	1	1	1	2	2	3	3	4	
K	4	6	6	8	8	10	10	12	12	14	
N	-	-	-	100	100	100	100	100	100	100	
P	1	1	1	2	2	2	2	2	2	2	
Q	-	-	158	208	258	308	358	408	458	508	
R	0	0	1	1	1	1	1	1	1	1	
Allowable static load on rod tip (N)	196	196	196	196	196	196	196	196	184	169	
Allowable static torque on rod tip (N·m)	10	10	10	10	10	10	10	10	10	10	
3,000km	Allowable dynamic load on rod tip (N)	98	98	98	95	85	76	68	62	57	
	Load offset 100mm	50	50	50	50	50	50	50	50	49	
5,000km	Allowable dynamic load on rod tip (N)	50	50	50	50	50	50	50	48	44	
	Load offset 100mm	50	50	50	50	50	50	50	48	44	
Mass (kg)	RCP6W	w/o brake	3.8	4.2	4.7	5.1	5.6	6.0	6.5	6.9	7.4
		w/ brake	3.9	4.3	4.8	5.2	5.7	6.1	6.6	7.0	7.5
	RCP6SW	w/o brake	4.0	4.4	4.9	5.3	5.8	6.2	6.7	7.1	7.6
		w/ brake	4.1	4.5	5.0	5.4	5.9	6.3	6.8	7.2	7.7

② Applicable Controllers

The RCP6 series actuators can be operated by the controllers indicated below. Please select the type depending on your intended use. * Please refer to P.271 for more information about the built-in controller of RCP6S series.

Name	External view	Max. number of controlled axes	Input power	Control method				Maximum number of positioning points	Reference page
				Positioner	Pulse train	Program	Network * Option		
PCON-CYB/PLB/POB		1	DC24V	●	●	-	Network cannot be selected	64	Please contact IAI for more information.
PCON-CB/CGB		1		* Option	* Option	-	DeviceNet MECHATROLINK CC-Link EtherCAT EtherNet/IP CANopen CompoNet	512 (768 for network spec.)	See P.255
MCON-C/CG		8		This model is network-compatible only.				Note: The type of compatible networks will vary depending on the controller. Please refer to reference page for more information.	256
MCON-LC/LCG		6		-	-	●	256		Please contact IAI for more information.
MSEL-PC/PG		4	Single-phase 100 ~ 230 VAC	-	-	●	30,000	Please contact IAI for more information.	
RCM-P6PC		1	Usable within the RCP6S Gateway system.				768	See P.279	

* For the MCON controller, high-output enabled operation is only available if "high-output setting" is selected as an option. The maximum connectable axes with high-output enabled are C: 4 and LC: 3.

RCP6(S)W-WRA12R

Dust/Splash-Proof Spec
Battery-less Absolute
Motor Unit Type
Side-mounted Motor
Body Width 120* mm
24v Stepper Motor

Model Specification Items	Series	Type	Encoder Type	Motor Type	Lead	Stroke	Applicable Controller/I/O Type	Cable Length	Options
	WRA12R	WA	42P						
	RCP6W: Separate Controller RCP6SW: Built-in Controller	WA: Battery-less Absolute	42P: Stepper Motor 42□ Size	12 :12mm 6 : 6mm 3 : 3mm	50:50mm 500:500mm (Every 50mm)	[RCP6W] P3 : PCON MCON MSEL P5 : RCM-P6PC [RCP6SW] SE: SIO Type	N : None P : 1m S : 3m M : 5m XC□ : Specified Length R□ : Robot Cable	Please refer to the options table below. * Please make sure to specify either ML or MR when ordering the side-mounted motor type.	

* RCP6 does not include a controller. RCP6S includes a built-in controller.
* Please refer to P.20 for more information about the model specification items.

* Body width does not include the width of the side-mounted motor.

Radial Load Applicable

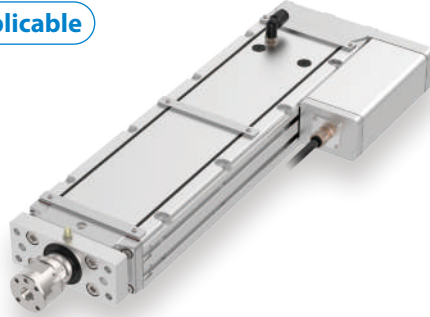
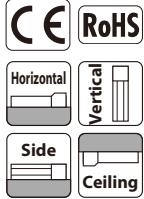

The figure above is the motor side-mounted to left (ML).

*Some limitations may apply to horizontal/side/ceiling mountings depending on the model. See page 204. Please contact IAI for more information.

- The maximum acceleration/deceleration is 1G for horizontal, and 0.5G for vertical use.
- The actuator specifications displays the payload's maximum value, but it will vary depending on the acceleration and speed. Please refer to the "Selection Guidelines" (Tables of Payload by Speed/Acceleration) on P.241 for more details.
- The radial cylinder is equipped with a built-in guide. Please refer to the graphs shown on P.246 and after for the allowable load mass.
- Please refer to P.205 for performing push-motion operation.
- Depending on the ambient operating temperature, duty control is necessary for the RCP6SW (built-in controller type) with lead 3/6. Please refer to P.247 for more information.
- The cable joint connector is not splash-proofed, so it should be located where there is no splash.
- The RCP6SW with built-in controller does not have a teaching tool connection port. Connect the teaching tool to the gateway unit and configure parameter data etc. via the gateway unit.



Correlation Diagrams of Speed and Payload

If the ambient temperature is 5°C or below, the speed will be lower than when it exceeds 5°C.

High-output enabled with PCON/MCON/MSEL connected.

RCP6(S)W-WRA12R Horizontal mount (When ambient temperature exceeds 5°C)

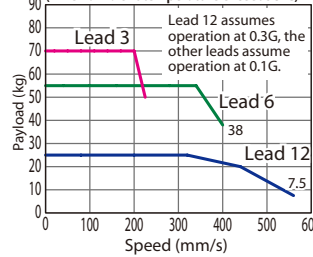

RCP6(S)W-WRA12R Horizontal mount (When ambient temperature is 5°C or below)

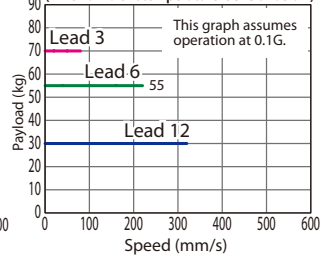

High-output enabled with PCON/MCON/MSEL connected.

RCP6(S)W-WRA12R Vertical mount (When ambient temperature exceeds 5°C)

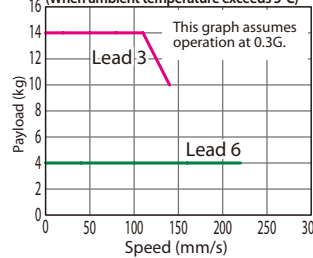

RCP6(S)W-WRA12R Vertical mount (When ambient temperature is 5°C or below)

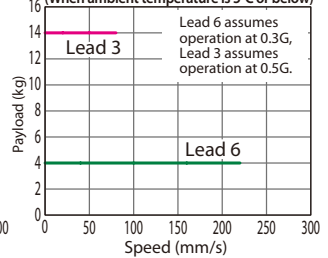

Actuator Specifications

Lead and Payload

Model Number	Lead (mm)	Max. Payload		Max. Push Force (N)**	Stroke (mm)
		Horizontal (kg)*	Vertical (kg)		
RCP6(S)W-WRA12R-WA-42P-12-①-②-③-④	12	30	-	93	50~500 (Every 50mm)
RCP6(S)W-WRA12R-WA-42P-6-①-②-③-④	6	55	4	185	
RCP6(S)W-WRA12R-WA-42P-3-①-②-③-④	3	70	14	370	

Legend: ① Stroke ② Applicable controllers/I/O type ③ Cable length ④ Options

Stroke and Max Speed (Unit: mm/s)

Lead (mm)	50~400 (Every 50mm)	450	500
12	560 [320]		
6	400 <<220>> [220]	375 <<220>> [220]	
3	225 <<140>> [80]	220 <<140>> [80]	185 <<140>> [80]

Values in brackets <> are for vertical use.
Values in brackets [] are when ambient temperature is 5°C or below.

① Stroke

Stroke (mm)	RCP6W	RCP6SW	Stroke (mm)	RCP6W	RCP6SW
50	○	○	300	○	○
100	○	○	350	○	○
150	○	○	400	○	○
200	○	○	450	○	○
250	○	○	500	○	○

④ Options

Name	Option Code	Reference Page
Actuator cable length 2m	Not specified	See P.197
Actuator cable length 5m	AC5	See P.197
Actuator cable length 10m	AC10	See P.197
Actuator cable length 15m	AC15	See P.197
Brake	B	See P.197
Cable exit direction (Bottom)	CJB	See P.197
Cable exit direction (Outside)	CJO	See P.197
Cable exit direction (Top)	CJT	See P.197
Flange	FL	See P.198
Motor side-mounted to left (standard)	ML	See P.201
Motor side-mounted to right	MR	See P.201
Non-motor end specification	NM	See P.202
T-slot nut bar (Left)	NTBL	See P.202
T-slot nut bar (Right)	NTBR	See P.202

* Be sure to confirm with the "Selection Notes (P.204)" when selecting options.

③ Cable Length

Cable Type	Cable Code	RCP6W			RCP6SW
		P3	P5	SE	
Standard	P (1m)	○	○	○	
	S (3m)	○	○	○	
	M (5m)	○	○	○	
	X06 (6m) ~ X10 (10m)	○	○	○	
Specified length	X11 (11m) ~ X15 (15m)	○	○	○	
	X16 (16m) ~ X18 (18m)	○	○	○	
	R01 (1m) ~ R03 (3m)	○	○	○	
	R04 (4m) ~ R05 (5m)	○	○	○	
Robot cable	R06 (6m) ~ R10 (10m)	○	○	○	
	R11 (11m) ~ R15 (15m)	○	○	○	
	R16 (16m) ~ R18 (18m)	○	○	○	

* Select the length of the actuator cable and the actuator/controller connection cable so that the total is 20m or less.

* Please refer to P. 267 and 283 for more information regarding the maintenance cables.

Actuator Specifications

Item	Description
Drive system	Ball screw φ10mm, rolled C10
Positioning repeatability	±0.01mm
Lost motion	0.1mm or less
Rod	φ30mm
Rod non-rotation precision	0 degrees
Allowable load and torque on rod tip	See P. 246
Rod tip overhang distance	100mm or less
Protective structure	IP65 (IEC 60529/JIS C 0920)
Ambient operating temp. & humidity	0~40°C, 85% RH or less (Non-condensing)

CAD drawings can be downloaded from our website.
www.intelligentactuator.com



- *1 When the rod is returning to its home position, please be careful of interference from surrounding objects, as it will travel until it reaches the M.E.
- M.E: Mechanical end S.E: Stroke end
- *2 If the object attached to the rod has a long overhang length, or precise angular adjustment of the object is required, please do not use the reamed hole when the object is attached to the rod.

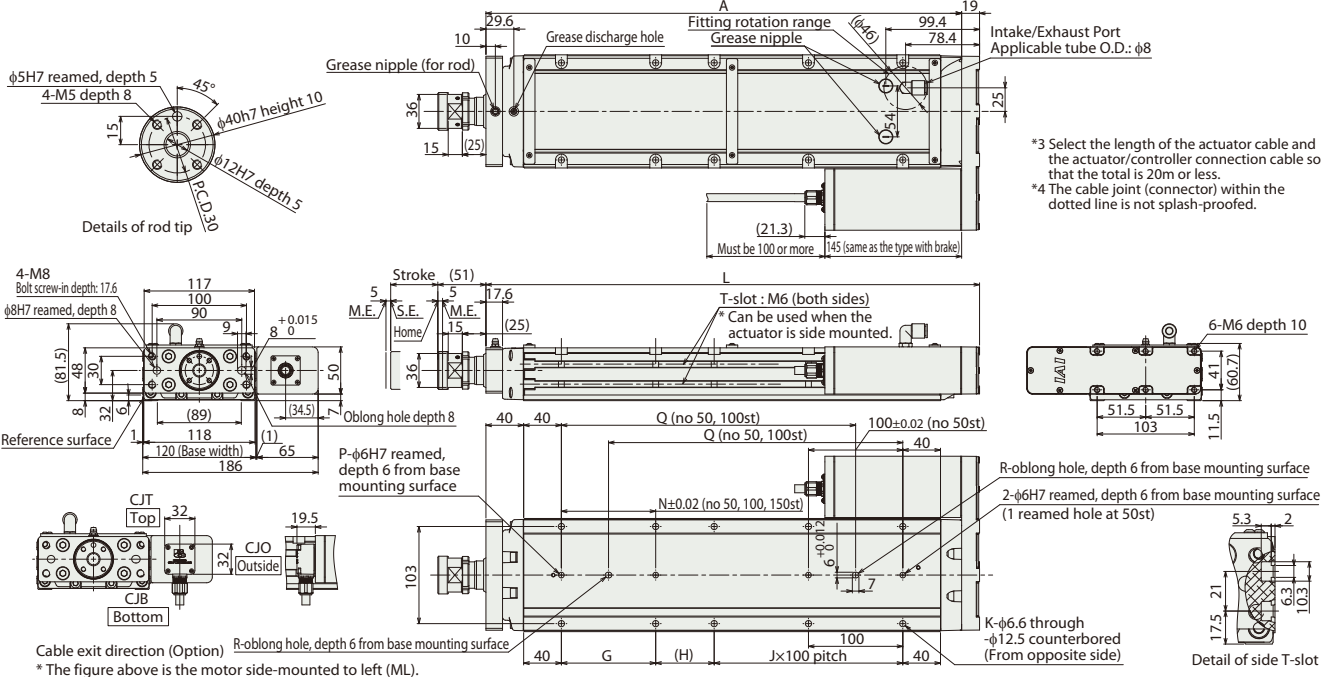

RCP6SW-WRA12R

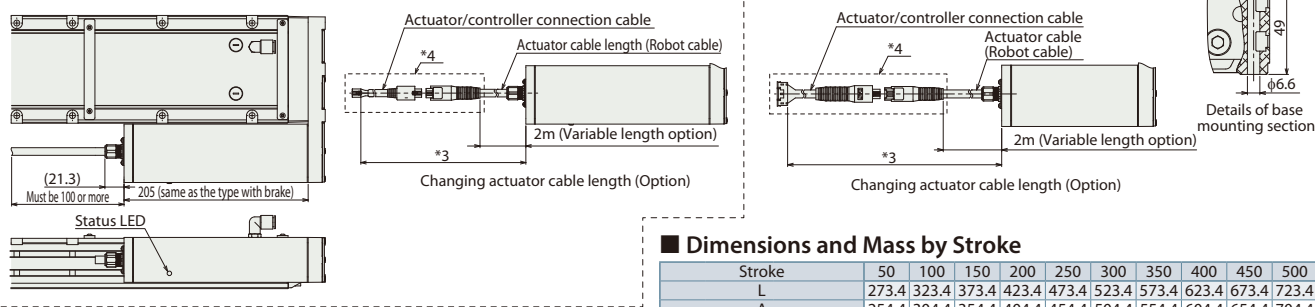

Rod Deflection of RCP6(S)W-WRA12R (Reference Values)

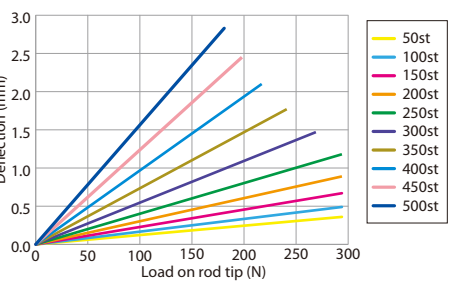

* Please refer to P.254 for more information on component materials.

Dimensions and Mass by Stroke

Stroke	50	100	150	200	250	300	350	400	450	500
L	273.4	323.4	373.4	423.4	473.4	523.4	573.4	623.4	673.4	723.4
A	254.4	304.4	354.4	404.4	454.4	504.4	554.4	604.4	654.4	704.4
G	-	-	-	100	100	100	100	100	100	100
H	112	62	112	62	112	62	112	62	112	62
J	0	1	1	1	1	2	2	3	3	4
K	4	6	6	8	8	10	10	12	12	14
N	-	-	-	100	100	100	100	100	100	100
P	1	1	1	2	2	2	2	2	2	2
Q	-	-	162	212	262	312	362	412	462	512
R	0	0	1	1	1	1	1	1	1	1
Allowable static load on rod tip (N)	294	294	294	294	294	269	241	218	198	181
Allowable static torque on rod tip (N-m)	20	20	20	20	20	20	20	20	20	20
3,000km	Allowable dynamic load on rod tip (N)	147	147	137	121	107	96	87	79	72
	Load offset 0mm	100	100	100	100	99	90	82	75	68
	Load offset 100mm	100	100	100	100	99	90	82	75	68
	Allowable dynamic torque on rod tip (N-m)	10.0	10.0	10.0	10.0	9.9	9.0	8.2	7.5	6.8
5,000km	Allowable dynamic load on rod tip (N)	147	133	115	101	90	80	72	65	59
	Load offset 0mm	100	100	100	92	83	75	68	62	56
	Load offset 100mm	100	100	100	92	83	75	68	62	56
	Allowable dynamic torque on rod tip (N-m)	10.0	10.0	10.0	9.2	8.3	7.5	6.8	6.2	5.6
Mass (kg)	RCP6W w/o brake	5.4	6.0	6.7	7.3	8.0	8.6	9.3	9.9	10.6
	w/ brake	5.5	6.1	6.8	7.4	8.1	8.7	9.4	10.0	10.7
	RCP6SW w/o brake	5.5	6.1	6.8	7.4	8.1	8.7	9.4	10.0	10.7
	w/ brake	5.6	6.2	6.9	7.5	8.2	8.8	9.5	10.1	10.8

② Applicable Controllers

The RCP6 series actuators can be operated by the controllers indicated below. Please select the type depending on your intended use. * Please refer to P.271 for more information about the built-in controller of RCP6S series.

Name	External view	Max. number of controlled axes	Input power	Control method				Maximum number of positioning points	Reference page
				Positioner	Pulse train	Program	Network * Option		
PCON-CYB/PLB/POB		1	DC24V	●	●	-	Network cannot be selected	64	Please contact IAI for more information.
PCON-CB/CGB		1		* Option	* Option	-	DeviceNet MECHATROLINK CC-Link EtherCAT EtherNet/IP PROFINET CompoNet	512 (768 for network spec.)	See P.255
MCON-C/CG		8		This model is network-compatible only.				Note: The type of compatible networks will vary depending on the controller. Please refer to reference page for more information.	256
MCON-LC/LCG		6		-	-	●	256		Please contact IAI for more information.
MSEL-PC/PG		4	Single-phase 100 ~ 230 VAC	-	-	●	30,000	Please contact IAI for more information.	
RCM-P6PC		1		Usable within the RCP6S Gateway system.				768	See P.279

* For the MCON controller, high-output enabled operation is only available if "high-output setting" is selected as an option. The maximum connectable axes with high-output enabled are: C: 4 and LC: 3.

RCP6(S)W-WRA14R

Dust/Splash-Proof Spec
Battery-less Absolute
Motor Unit Type
Side-mounted Motor
Body Width 140* mm
24v Stepper Motor

Model Specification Items	Series	Type	Encoder Type	Motor Type	Lead	Stroke	Applicable Controller/I/O Type	Cable Length	Options
	WRA14R	WA	56P						
	RCP6W: Separate Controller RCP6SW: Built-in Controller	WA: Battery-less Absolute	56P: Stepper Motor 56□ Size	16 : 16mm 8 : 8mm 4 : 4mm	50:50mm 600:600mm (Every 50mm)	[RCP6W] P3 : PCON MCON MSEL P5 : RCM-P6PC [RCP6SW] SE: SIO Type	N : None P : 1m S : 3m M : 5m XC□ : Specified Length R□ : Robot Cable	Please refer to the options table below. * Please make sure to specify either ML or MR when ordering the side-mounted motor type.	

* RCP6 does not include a controller. RCP6S includes a built-in controller.
* Please refer to P.20 for more information about the model specification items.

Radial Load Applicable

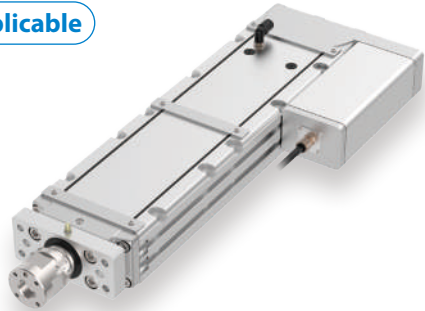
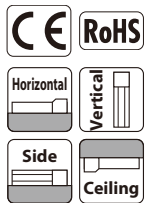

The figure above is the motor side-mounted to left (ML).

*Some limitations may apply to horizontal/side/ceiling mountings depending on the model. See page 204. Please contact IAI for more information.

- POINT Selection Notes**
- (1) The maximum acceleration/deceleration is 1G for horizontal, and 0.5G for vertical use.
 - (2) The actuator specifications displays the payload's maximum value, but it will vary depending on the acceleration and speed. Please refer to the "Selection Guidelines" (Tables of Payload by Speed/Acceleration) on P.242 for more details.
 - (3) The radial cylinder is equipped with a built-in guide. Please refer to the graphs shown on P.245 and after for the allowable load mass.
 - (4) Please refer to P.205 for performing push-motion operation.
 - (5) Depending on the ambient operating temperature, duty control is necessary for the RCP6SW (built-in controller type) with lead 4/8/16. Please refer to P.247 for more information.
 - (6) The cable joint connector is not splash-proofed, so it should be located where there is no splash.
 - (7) The RCP6SW with built-in controller does not have a teaching tool connection port. Connect the teaching tool to the gateway unit and configure parameter data etc. via the gateway unit.

Correlation Diagrams of Speed and Payload

If the ambient temperature is 5°C or below, the speed will be lower than when it exceeds 5°C.

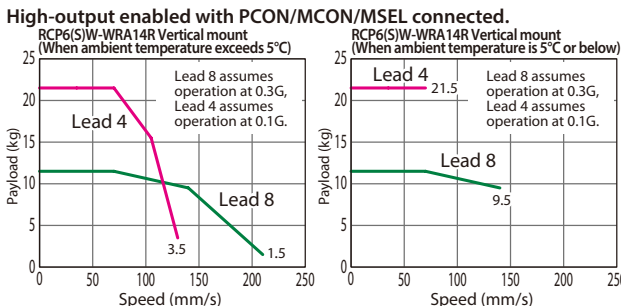
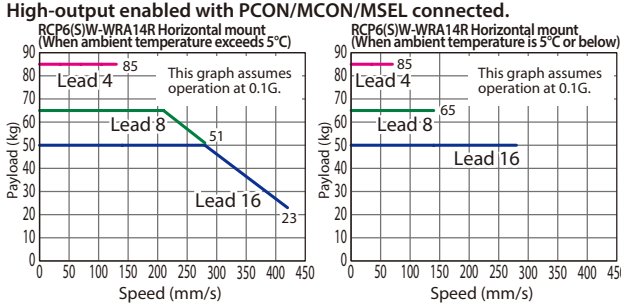

Actuator Specifications

Lead and Payload

Model Number	Lead (mm)	Max. Payload		Max. Push Force (N)**	Stroke (mm)
		Horizontal (kg)*	Vertical (kg)		
RCP6(S)W-WRA14R-WA-56P-16-①-②-③-④	16	50	-	273	50~600 (Every 50mm)
RCP6(S)W-WRA14R-WA-56P-8-①-②-③-④	8	65	11.5	547	
RCP6(S)W-WRA14R-WA-56P-4-①-②-③-④	4	85	21.5	1,094	

Legend: ① Stroke ② Applicable controllers/I/O type ③ Cable length ④ Options

Stroke and Max Speed (Unit: mm/s)

Lead (mm)	50~600 (Every 50mm)
16	420 [280]
8	280 <210> [140]
4	130 [70]

Values in brackets <> are for vertical use.
Values in brackets [] are when ambient temperature is 5°C or below.

① Stroke

Stroke (mm)	RCP6W	RCP6SW	Stroke (mm)	RCP6W	RCP6SW
50	○	○	350	○	○
100	○	○	400	○	○
150	○	○	450	○	○
200	○	○	500	○	○
250	○	○	550	○	○
300	○	○	600	○	○

④ Options

Name	Option Code	Reference Page
Actuator cable length 2m	Not specified	See P.197
Actuator cable length 5m	ACS	See P.197
Actuator cable length 10m	AC10	See P.197
Actuator cable length 15m	AC15	See P.197
Brake	B	See P.197
Cable exit direction (Bottom)	CJB	See P.197
Cable exit direction (Outside)	CJO	See P.197
Cable exit direction (Top)	CJT	See P.197
Flange	FL	See P.198
Motor side-mounted to left (standard)	ML	See P.201
Motor side-mounted to right	MR	See P.201
Non-motor end specification	NM	See P.202
T-slot nut bar (Left)	NTBL	See P.202
T-slot nut bar (Right)	NTBR	See P.202

* Be sure to confirm with the "Selection Notes (P.204)" when selecting options.

③ Cable Length

Cable Type	Cable Code	RCP6W			RCP6SW
		P3	P5	SE	
Standard	P(1m)	○	○	○	○
	S(3m)	○	○	○	○
	M(5m)	○	○	○	○
	X06(6m)~X10(10m)	○	○	○	○
Specified length	X11(11m)~X15(15m)	○	○	○	○
	X16(16m)~X18(18m)	○	○	○	○
	R01(1m)~R03(3m)	○	○	○	○
Robot cable	R04(4m)~R05(5m)	○	○	○	○
	R06(6m)~R10(10m)	○	○	○	○
	R11(11m)~R15(15m)	○	○	○	○
	R16(16m)~R18(18m)	○	○	○	○

* Select the length of the actuator cable and the actuator/controller connection cable so that the total is 20m or less.
* Please refer to P. 267 and 283 for more information regarding the maintenance cables.

Actuator Specifications

Item	Description
Drive system	Ball screw φ12mm, rolled C10
Positioning repeatability	±0.01mm
Lost motion	0.1mm or less
Rod	φ40mm
Rod non-rotation precision	0 degrees
Allowable load and torque on rod tip	See P. 246
Rod tip overhang distance	150mm or less
Protective structure	IP65 (IEC 60529/JIS C 0920)
Ambient operating temp. & humidity	0~40°C, 85% RH or less (Non-condensing)

CAD drawings can be downloaded from our website.
www.intelligentactuator.com



- *1 When the rod is returning to its home position, please be careful of interference from surrounding objects, as it will travel until it reaches the M.E.
M.E: Mechanical end S.E: Stroke end
- *2 If the object attached to the rod has a long overhang length, or precise angular adjustment of the object is required, please do not use the reamed hole when the object is attached to the rod.

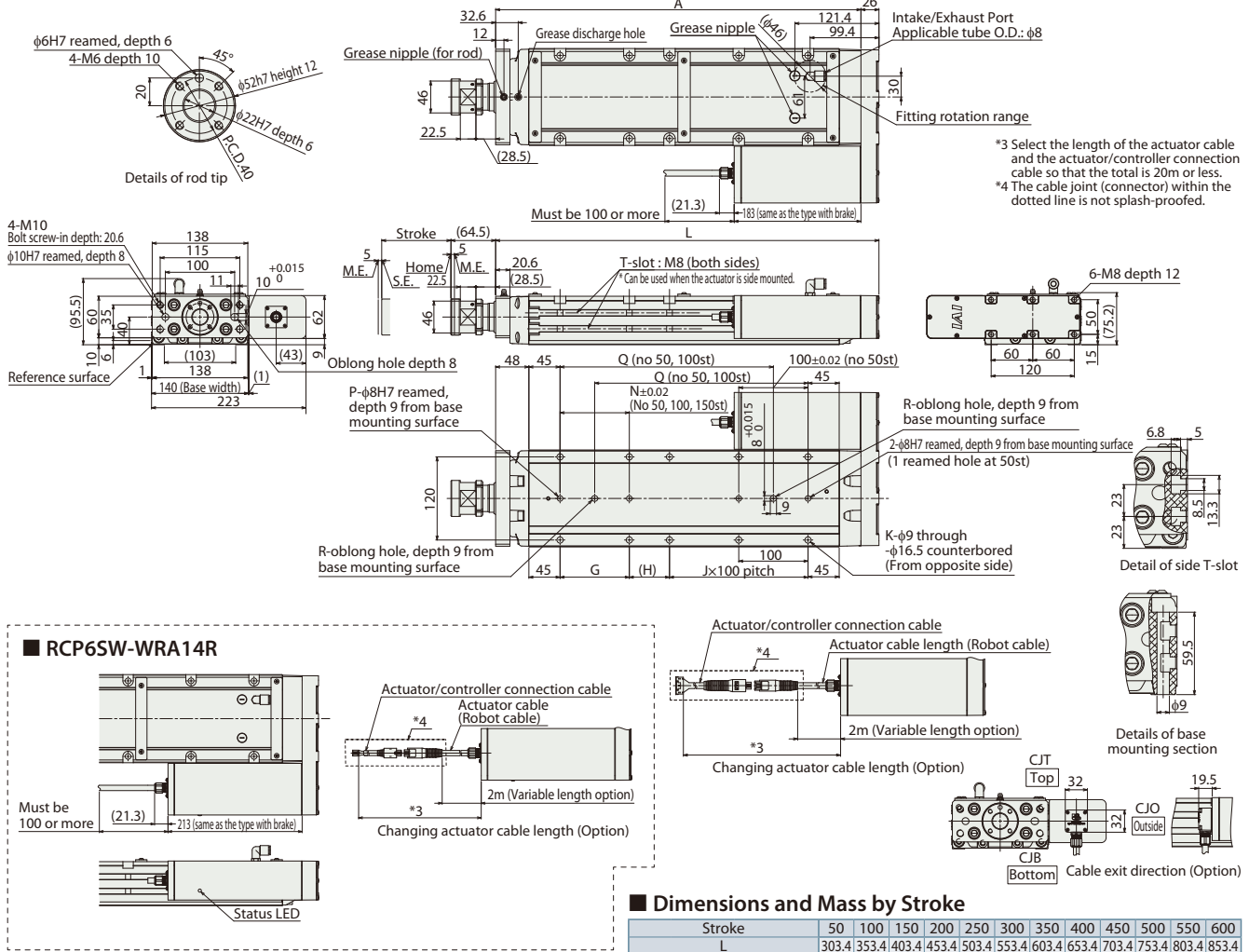

RCP6SW-WRA14R

Rod Deflection of RCP6(S)W-WRA14R (Reference Values)

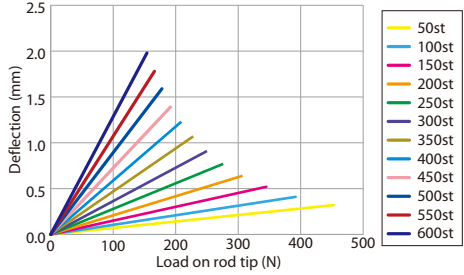

* Please refer to P.254 for more information on component materials.

Dimensions and Mass by Stroke

Stroke	50	100	150	200	250	300	350	400	450	500	550	600
L	303.4	353.4	403.4	453.4	503.4	553.4	603.4	653.4	703.4	753.4	803.4	853.4
A	277.4	327.4	377.4	427.4	477.4	527.4	577.4	627.4	677.4	727.4	777.4	827.4
G	-	-	-	100	100	100	100	100	100	100	100	100
H	108	58	108	58	108	58	108	58	108	58	108	58
J	0	1	1	1	1	2	2	3	3	4	4	5
K	4	6	6	8	8	10	10	12	12	14	14	16
N	-	-	-	100	100	100	100	100	100	100	100	100
P	1	1	1	2	2	2	2	2	2	2	2	2
Q	-	-	158	208	258	308	358	408	458	508	558	608
R	0	0	1	1	1	1	1	1	1	1	1	1
Allowable static load on rod tip (N)	454	392	345	307	276	251	229	210	193	179	166	154
Allowable static torque on rod tip (N·m)	30	30	30	30	30	30	30	30	30	30	30	30
3,000km	Allowable dynamic load on rod tip (N)	199	170	148	131	117	104	94	85	77	70	64
	Load offset 100mm	100	100	100	100	100	95	87	79	72	66	60
	Allowable dynamic torque on rod tip (N·m)	15.0	15.0	15.0	15.0	15.0	14.3	13.0	11.8	10.8	9.9	9.0
5,000km	Allowable dynamic load on rod tip (N)	167	143	124	109	97	87	78	70	63	57	51
	Load offset 100mm	100	100	100	96	87	79	71	65	59	53	48
	Allowable dynamic torque on rod tip (N·m)	15.0	15.0	15.0	14.4	13.0	11.8	10.7	9.7	8.8	8.0	7.3
Mass (kg)	RCP6W w/o brake	9.4	10.2	11.1	12.0	12.9	13.8	14.7	15.6	16.5	17.4	18.3
	w/ brake	9.5	10.3	11.2	12.1	13.0	13.9	14.8	15.7	16.6	17.5	18.4
	RCP6SW w/o brake	9.6	10.4	11.3	12.2	13.1	14.0	14.9	15.8	16.7	17.6	18.5
	w/ brake	9.7	10.5	11.4	12.3	13.2	14.1	15.0	15.9	16.8	17.7	18.6

② Applicable Controllers

The RCP6 series actuators can be operated by the controllers indicated below. Please select the type depending on your intended use. * Please refer to P.271 for more information about the built-in controller of RCP6S series.

Name	External view	Max. number of controlled axes	Input power	Control method				Maximum number of positioning points	Reference page
				Positioner	Pulse train	Program	Network * Option		
PCON-CYB/PLB/POB		1	DC24V	●	●	-	Network cannot be selected	64	Please contact IAI for more information.
PCON-CB/CGB		1		* Option	* Option	-	DeviceNet MECHATROLINK CC-Link EtherCAT EtherNet/IP	512 (768 for network spec.)	See P.255
MCON-C/CG		8		This model is network-compatible only.					
MCON-LC/LCG		6		-	-	●	256	Please contact IAI for more information.	
MSEL-PC/PG		4	Single-phase 100 ~ 230 VAC	-	-	●	30,000	Please contact IAI for more information.	
RCM-P6PC		1		Usable within the RCP6S Gateway system.				768	See P.279

* For the MCON controller, high-output enabled operation is only available if "high-output setting" is selected as an option. The maximum connectable axes with high-output enabled are C: 4 and LC: 3.

RCP6(S)W-WRA16R

Dust/Splash-Proof Spec | Battery-less Absolute | Motor Unit Type | Side-mounted Motor | Body Width 160mm | 24v Stepper Motor

Model Specification Items	Series	Type	Encoder Type	Motor Type	Lead	Stroke	Applicable Controller/I/O Type	Cable Length	Options
	WRA16R	WA	60P						
	RCP6W: Separate Controller RCP6SW: Built-in Controller	WA: Battery-less Absolute	60P: Stepper Motor 60□ Size	20 :20mm 10 :10mm 5 : 5mm	50:50mm 800:800mm (Every 50mm)	[RCP6W] P4 : PCON-CFB/ CGFB [RCP6SW] SE: SIO Type	N : None P : 1m S : 3m M : 5m XC□ : Specified Length R□□ : Robot Cable	Please refer to the options table below. * Please make sure to specify either ML or MR when ordering the side-mounted motor type.	

* RCP6 does not include a controller. RCP6S includes a built-in controller.
* Please refer to P.20 for more information about the model specification items.

* Body width does not include the width of the side-mounted motor.

Radial Load Applicable

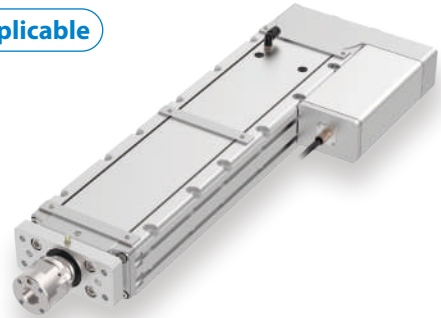
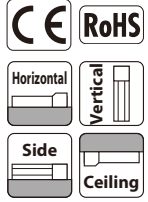

The figure above is the motor side-mounted to left (ML).

*Some limitations may apply to horizontal/side/ceiling mountings depending on the model. See page 204. Please contact IAI for more information.

- POINT Selection Notes**
- (1) The maximum acceleration/deceleration is 0.1G for lead 5 and 0.2G for lead 10/20.
 - (2) The actuator specifications displays the payload's maximum value, but it will vary depending on the acceleration and speed. Please refer to the "Selection Guidelines" (Tables of Payload by Speed/Acceleration) on P.242 for more details.
 - (3) The radial cylinder is equipped with a built-in guide. Please refer to the graphs shown on P.245 and after for the allowable load mass.
 - (4) Please refer to P.205 for performing push-motion operation.
 - (5) For RCP6SW (built-in controller type), please limit the duty cycle to 70% or less.
 - (6) The service life of an actuator with lead 5 varies depending on the payload when using vertically. Please refer to P. 206 for more information.
 - (7) The cable joint connector is not splash-proofed, so it should be located where there is no splash.
 - (8) The RCP6SW with built-in controller does not have a teaching tool connection port. Connect the teaching tool to the gateway unit and configure parameter data etc. via the gateway unit.

Correlation Diagrams of Speed and Payload

If the ambient temperature is 5°C or below, the speed will be lower than when it exceeds 5°C.

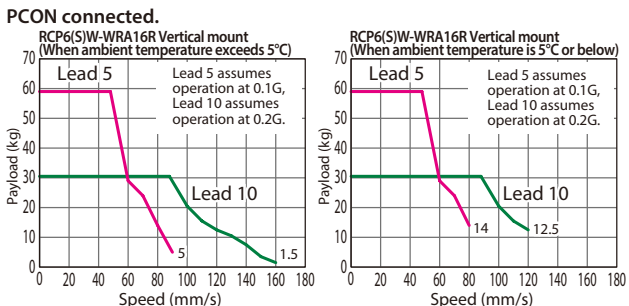
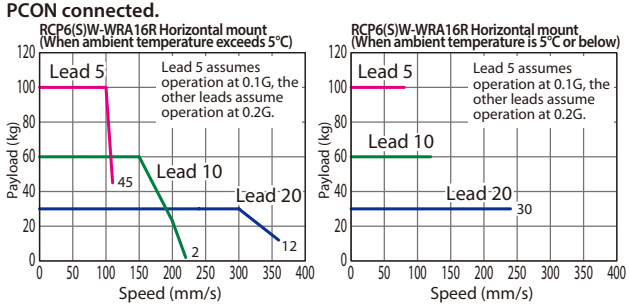

Actuator Specifications

Lead and Payload

* Horizontal external guide rail required for horizontal payload.
** Push force only available during push mode w / limited speed.

Model Number	Lead (mm)	Max. Payload Horizontal (kg)*	Max. Payload Vertical (kg)	Max. Push Force (N)**	Stroke (mm)
RCP6(S)W-WRA16R-WA-60P-20-①-②-③-④	20	30	-	500	50~800 (Every 50mm)
RCP6(S)W-WRA16R-WA-60P-10-①-②-③-④	10	60	30.5	1,000	
RCP6(S)W-WRA16R-WA-60P-5-①-②-③-④	5	100	59	2,000	

Legend: ① Stroke ② Applicable controllers/I/O type ③ Cable length ④ Options

Stroke and Max Speed

(Unit: mm/s)

Lead (mm)	50	100~450 (Every 50mm)	500	550	600	650	700	750	800
20	280 [240]	360 [240]	340 [240]	295 [240]	260 [240]	225 [225]	200 [200]	180 [180]	
10	220 <160> [120]	195 <160> [120]	165 <160> [120]	145 [120]	125 [120]	110 [110]	100 [100]	90 [90]	
5	110 <90> [80]	95 <90> [80]	80 [80]	70 [70]	60 [60]	55 [55]	50 [50]	45 [45]	

Values in brackets < > are for vertical use.
Values in brackets [] are when ambient temperature is 5°C or below.

① Stroke

Stroke (mm)	RCP6W	RCP6SW	Stroke (mm)	RCP6W	RCP6SW
50	○	○	450	○	○
100	○	○	500	○	○
150	○	○	550	○	○
200	○	○	600	○	○
250	○	○	650	○	○
300	○	○	700	○	○
350	○	○	750	○	○
400	○	○	800	○	○

③ Cable Length

Cable Type	Cable Code	RCP6W	RCP6SW
Standard	P(1m)	○	○
	S(3m)	○	○
	M(5m)	○	○
Specified length	X06 (6m) ~X10 (10m)	○	○
	X11 (11m) ~X15 (15m)	○	○
	X16 (16m) ~X18 (18m)	○	○
Robot cable	R01 (1m) ~R03 (3m)	○	○
	R04 (4m) ~R05 (5m)	○	○
	R06 (6m) ~R10 (10m)	○	○
	R11 (11m) ~R15 (15m)	○	○
	R16 (16m) ~R18 (18m)	○	○

* Select the length of the actuator cable and the actuator/controller connection cable so that the total is 20m or less.
* Please refer to P. 267 and 283 for more information regarding the maintenance cables.

④ Options

Name	Option Code	Reference Page
Actuator cable length 2m	Not specified	See P.197
Actuator cable length 5m	AC5	See P.197
Actuator cable length 10m	AC10	See P.197
Actuator cable length 15m	AC15	See P.197
Brake	B	See P.197
Cable exit direction (Bottom)	CJB	See P.197
Cable exit direction (Outside)	CJO	See P.197
Cable exit direction (Top)	CJT	See P.197
Flange	FL	See P.198
Motor side-mounted to left (standard)	ML	See P.201
Motor side-mounted to right	MR	See P.201
Non-motor end specification	NM	See P.202
T-slot nut bar (Left)	NTBL	See P.202
T-slot nut bar (Right)	NTBR	See P.202

* Be sure to confirm with the "Selection Notes (P.204)" when selecting options.

Actuator Specifications

Item	Description
Drive system	Ball screw φ16mm, rolled C10
Positioning repeatability	±0.01mm
Lost motion	0.1mm or less
Rod	φ45mm
Rod non-rotation precision	0 degrees
Allowable load and torque on rod tip	See P. 246
Rod tip overhang distance	150mm or less
Protective structure	IP65 (IEC 60529/JIS C 0920)
Ambient operating temp. & humidity	0~40°C, 85% RH or less (Non-condensing)

CAD drawings can be downloaded from our website.
www.intelligentactuator.com



*1 When the rod is returning to its home position, please be careful of interference from surrounding objects, as it will travel until it reaches the M.E.
M.E: Mechanical end S.E: Stroke end

*2 If the object attached to the rod has a long overhang length, or precise angular adjustment of the object is required, please do not use the reamed hole when the object is attached to the rod.

*3 Select the length of the actuator cable and the actuator/controller connection cable so that the total is 20m or less.
*4 The cable joint (connector) within the dotted line is not splash-proofed.

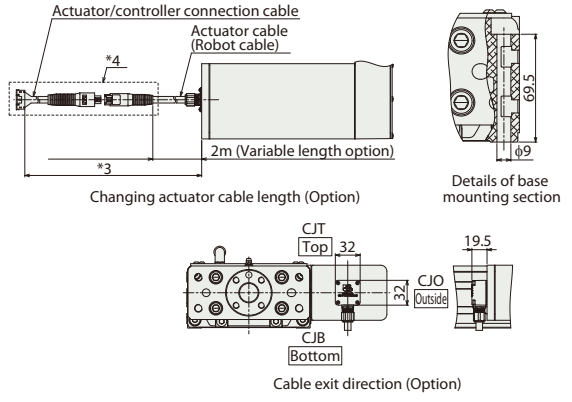
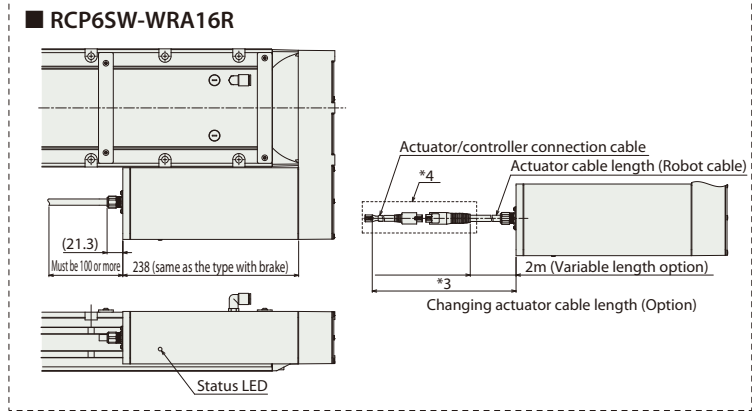
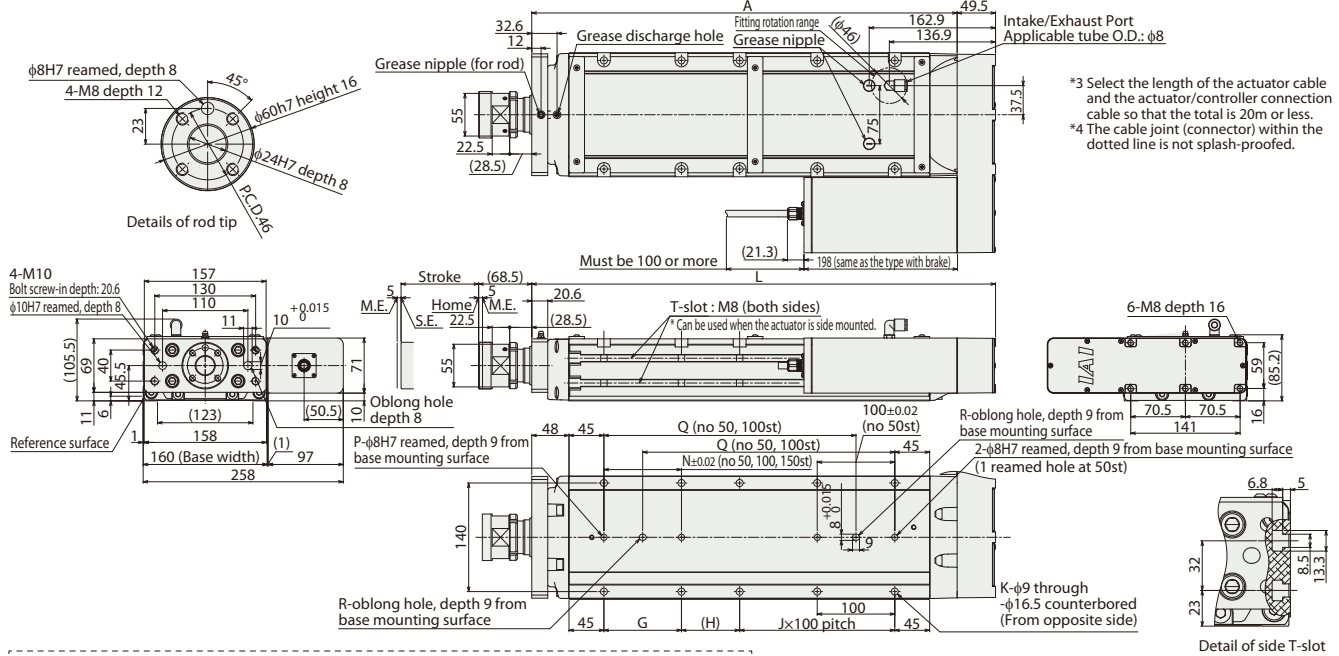

■ Rod Deflection of RCP6(S) W-WRA16R (Reference Values)

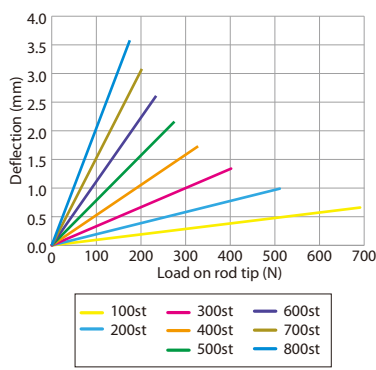

■ Dimensions and Mass by Stroke

Stroke	50	100	150	200	250	300	350	400	450	500	550	600	650	700	750	800
L	347.9	397.9	447.9	497.9	547.9	597.9	647.9	697.9	747.9	797.9	847.9	897.9	947.9	997.9	1,047.9	1,097.9
A	298.4	348.4	398.4	448.4	498.4	548.4	598.4	648.4	698.4	748.4	798.4	848.4	898.4	948.4	998.4	1,048.4
G	-	-	-	100	100	100	100	100	100	100	100	100	100	100	100	100
H	125	75	125	75	125	75	125	75	125	75	125	75	125	75	125	75
J	0	1	1	1	1	2	3	3	4	4	5	5	6	6	7	7
K	4	6	6	8	8	10	10	12	12	14	14	16	16	18	18	20
N	-	-	-	100	100	100	100	100	100	100	100	100	100	100	100	100
P	1	1	1	2	2	2	2	2	2	2	2	2	2	2	2	2
Q	-	-	175	225	275	325	375	425	475	525	575	625	675	725	775	825
R	0	0	1	1	1	1	1	1	1	1	1	1	1	1	1	1
Allowable static load on rod tip (N)	588	588	588	511	451	402	362	329	300	275	254	235	217	202	188	176
Allowable static torque on rod tip (N·m)	40	40	40	40	40	40	40	40	40	40	40	40	40	40	40	40
3,000km Allowable dynamic load on rod tip (N)	255	220	191	168	149	134	120	109	99	90	81	74	67	61	55	50
3,000km Allowable dynamic torque on rod tip (N·m)	133	133	133	133	133	122	111	101	92	84	77	70	64	58	53	48
5,000km Allowable dynamic load on rod tip (N)	200	200	200	200	200	183	167	152	138	126	115	105	96	87	79	71
5,000km Allowable dynamic torque on rod tip (N·m)	214	184	160	140	124	111	99	89	80	72	65	59	53	47	42	37
5,000km Allowable dynamic torque on rod tip (N·m)	133	133	133	124	112	101	91	83	75	68	62	56	50	45	40	36
Mass (kg) RCP6W w/o brake	13.5	14.7	15.9	17.0	18.1	19.3	20.4	21.6	22.7	23.9	25.0	26.2	27.3	28.5	29.6	30.8
Mass (kg) RCP6W w/ brake	13.8	15.0	16.2	17.3	18.4	19.6	20.7	21.9	23.0	24.2	25.3	26.5	27.6	28.8	29.9	31.1
Mass (kg) RCP6SW w/o brake	13.7	14.9	16.1	17.2	18.3	19.5	20.6	21.8	22.9	24.1	25.2	26.4	27.5	28.7	29.8	31.0
Mass (kg) RCP6SW w/ brake	14.0	15.2	16.4	17.5	18.6	19.8	20.9	22.1	23.2	24.4	25.5	26.7	27.8	29.0	30.1	31.3

* Please refer to P.254 for more information on component materials.

② Applicable Controllers

The RCP6 series actuators can be operated by the controllers indicated below. Please select the type depending on your intended use.* Please refer to P.271 for more information about the built-in controller of RCP6S series.

Name	External view	Max. number of controlled axes	Input power	Control method			Maximum number of positioning points	Reference page
				Positioner	Pulse train	Program		
PCON-CFB/CGFB		1	DC24V	●	●	-	512 (768 for network spec.)	See P.255
				Control method: Network * Option DeviceNet, CompoNet, EtherNet/IP, CC-Link, MECHATROLINK, EtherCAT, CANopen				

RCP6 Series Options

Brake

Option Code

B

Applicable Models

All Models

Description

When the actuator is mounted vertically, this works as a holding mechanism that prevents the slider, rod, or table from falling and damaging any attachments when the power or servo is turned off.

Cable Exit Direction

Option Code

CJT / CJR / CJL / CJB / CJO

Applicable Models

All Models

Description

This option allows you to change the exit direction of the motor-encoder cable to top, bottom, left, or right.

Coupled Motor Type

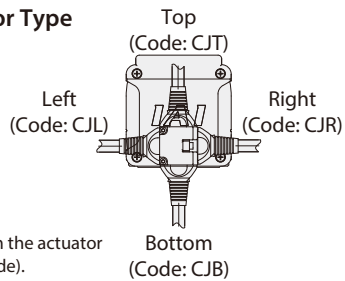

* When viewed from the actuator rear side (motor side).

Side-mounted Motor Type

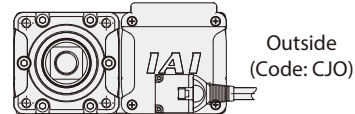

* When viewed from the actuator front side.

Tip Adapter (Flange)

Option Code

FFA

Applicable Models

RCP6(S)-RRA4□/RRA6□/RRA7□

Description

A rod-end tooling adapter with 4 threaded holes.

For RCP6(S)-RRA4□

Model Number: RCP6-FFA-RRA4

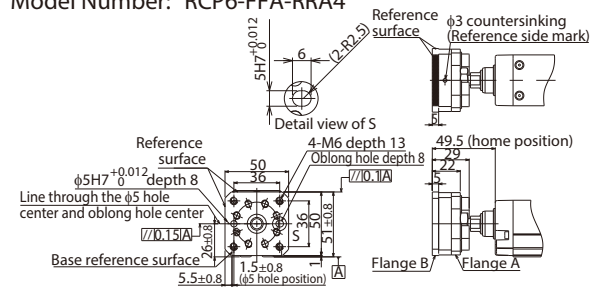

For RCP6(S)-RRA6□

Model Number: RCP6-FFA-RRA6

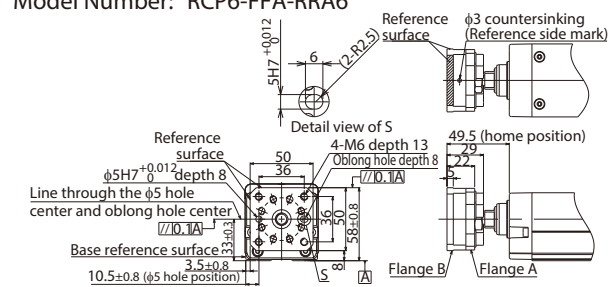

For RCP6(S)-RRA7□

Model Number: RCP6-FFA-RRA7

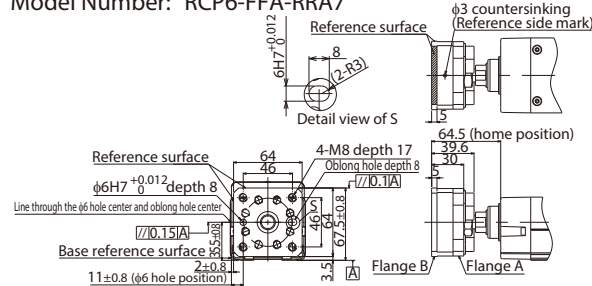

For RCP6(S)-WRA14□
Model Number: RCP6-FL-WRA14

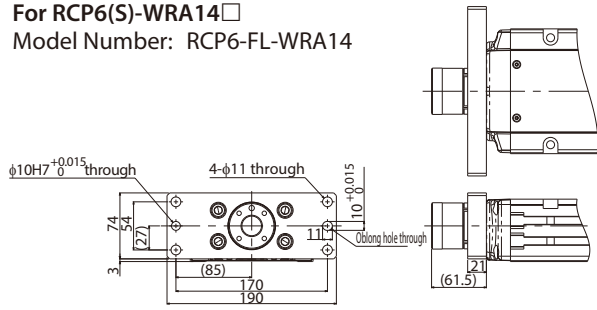

For RCP6(S)-WRA16□
Model Number: RCP6-FL-WRA16

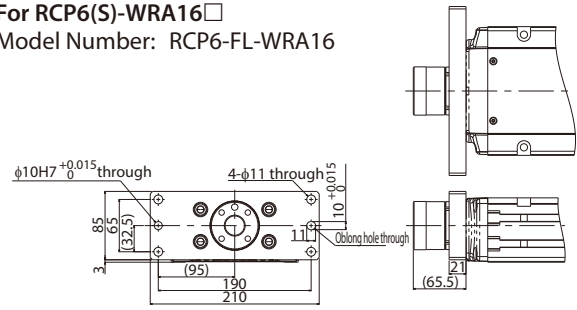

Foot Bracket

Option Code **FT** Applicable Models **RCP6(S)-RA4□/RA6□/RA7□/RA8□**

Description This is a bracket to fix the actuator with bolts from the top side. (Bolts are tightened from the top, not from the bottom)
For slider type actuators, when the moment load is large, please attach the foot brackets on all the mounting holes on the actuator.
The actuator body may be twisted or deformed if insufficient number of mounting foot brackets are used. Actuator life could also be shortened.
* Refer to the installation dimensions in the actuator drawing for the installation pitch between the foot brackets.

For RCP6(S)-RA4C
Model Number: RCP6-FT-RA4C
(Sold as a set of 2)

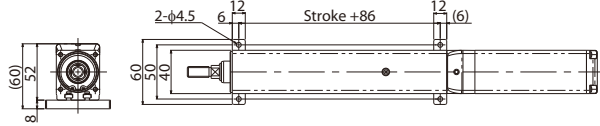

For RCP6(S)-RA6C
Model Number: RCP6-FT-RA6C
(Sold as a set of 2)

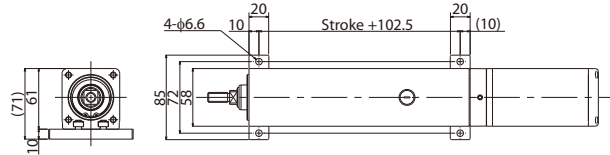

For RCP6(S)-RA7C
Model Number: RCP6-FT-RA7C
(Sold as a set of 2)

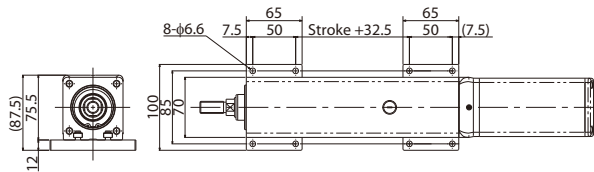

For RCP6(S)-RA8C
Model Number: RCP6-FT-RA8C
(Sold as a set of 2)

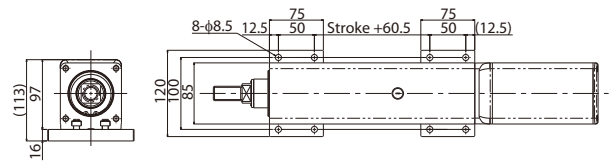

For RCP6(S)-RA4R
Model Number: RCP6-FT-RA4R-1 (For the motor side-mounted to the top)
(Sold as a set of 2)

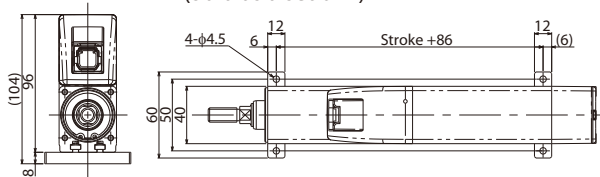

For RCP6(S)-RA6R
Model Number: RCP6-FT-RA6R-1 (For the motor side-mounted to the top)
(Sold as a set of 2)

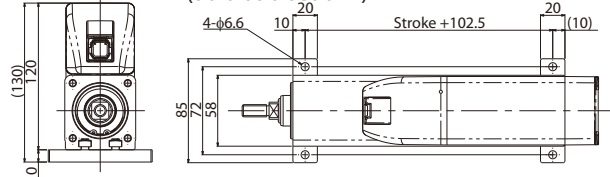

For RCP6(S)-RA7R
Model Number: RCP6-FT-RA7R-1 (For the motor side-mounted to the top)
(Sold as a set of 2)

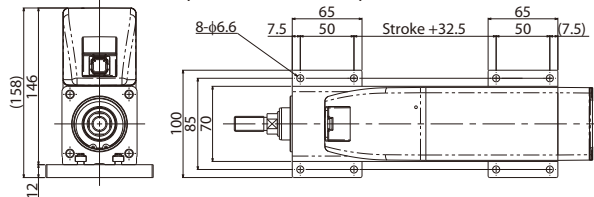

For RCP6(S)-RA8R
Model Number: RCP6-FT-RA8R-1 (For the motor side-mounted to the top)
(Sold as a set of 2)

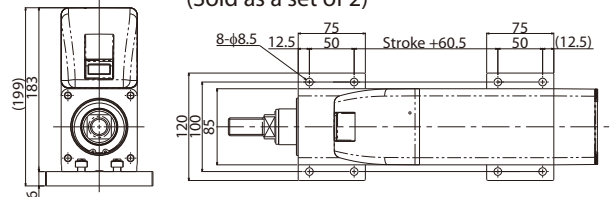

For RCP6(S)-RA4R

Model Number: RCP6-FT-RA4R-2 (For the motor side-mounted to the right/left)
(Sold as a set of 2)

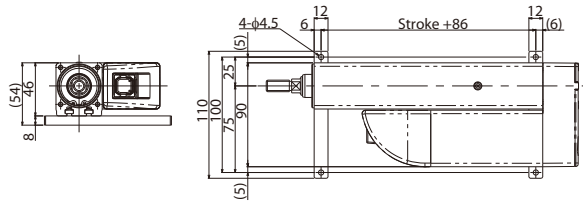

For RCP6(S)-RA4R

Model Number: RCP6-FT-RA4R-3 (For the motor side-mounted to the right/left)
(Sold as a set of 2)

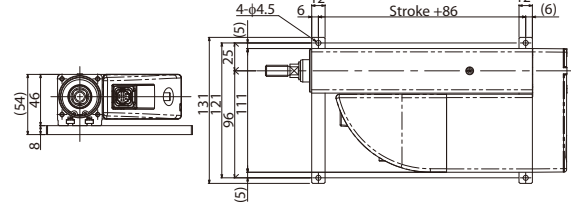

For RCP6(S)-RA6R

Model Number: RCP6-FT-RA6R-2 (For the motor side-mounted to the right/left)
(Sold as a set of 2)

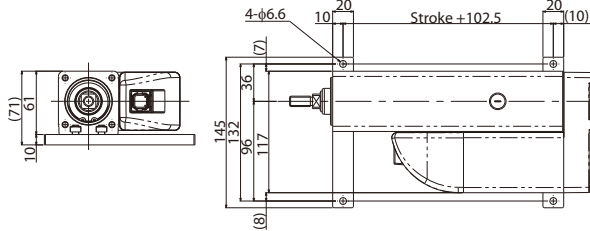

For RCP6(S)-RA7R

Model Number: RCP6-FT-RA7R-2 (For the motor side-mounted to the right/left)
(Sold as a set of 2)

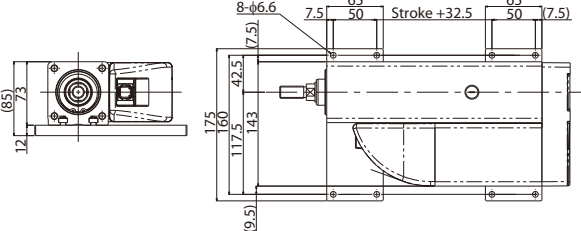

For RCP6(S)-RA8R

Model Number: RCP6-FT-RA8R-2 (For the motor side-mounted to the right/left)
(Sold as a set of 2)

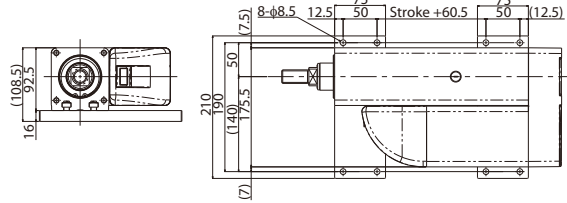

High-precision Specification

Option Code **HPR** Applicable Models RCP6(S)/RCP6(S)CR-SA□C/WSA□C

Description The positioning repeatability of the standard type of the RCP6(S)/RCP6(S)CR slider and wide slider models is ±0.01mm. If this option is selected, the positioning repeatability can be ±0.005mm. * This option can be selected for actuators with lead 12mm or less.

Tip Adapter (Keyway)

Option Code **KFA** Applicable Models RCP6(S)-RRA4□/RRA6□/RRA7□

Description A female threaded tip adapter with a parallel keyway.

For RCP6(S)-RRA4□

Model Number: RCP6-KFA-RRA4

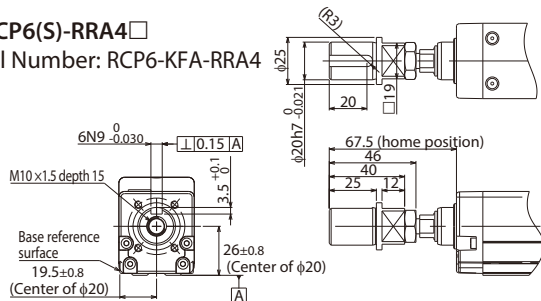

For RCP6(S)-RRA6□

Model Number: RCP6-KFA-RRA6

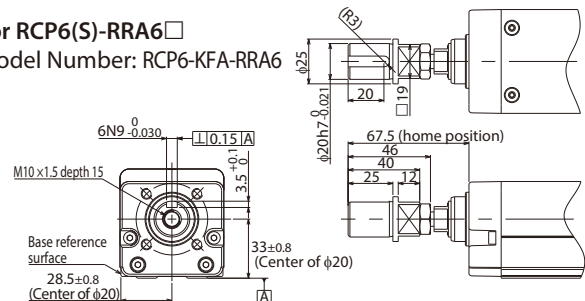

For RCP6(S)-RRA7□

Model Number: RCP6-KFA-RRA7

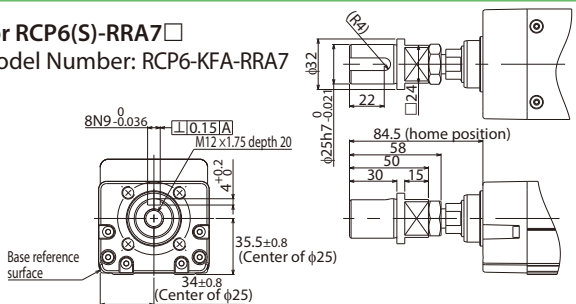

Foreword
Slider Type
Wide Slider Type
Rod Type
Radial Cylinder
Wide Radial Cylinder
Table Type
Cleanroom Slider
Cleanroom Wide Slider
Dust/Splash-Proof Rod
Dust/Splash-Proof Radial Cylinder*
Dust/Splash-Proof Wide Radial Cylinder
Options
Reference Data
Controller

Side-mounted Motor Direction

Option Code **ML / MR / MT**

Applicable Models **RCP6(S)-SA□/R/WSA□/R/RA□/R/RA□/R/RA□/R/WRA□/R/TA□/R**

Description This allows you to specify the direction of the side-mounted motor. As viewed from the motor side of the actuator, ML represents left, MR represents right, and MT represents top.

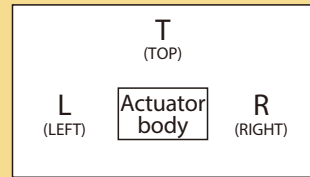

Tip Adapter (Internal Thread)

Option Code **NFA** Applicable Models **RCP6(S)-RA4□/RA6□/RA7□/RA8□/RAA4□/RAA6□/RAA7□/RAA8□**

Description A rod-end tooling adapter with 1 threaded hole.

For RCP6(S)-RA4□

Model Number: RCP6-NFA-RA4

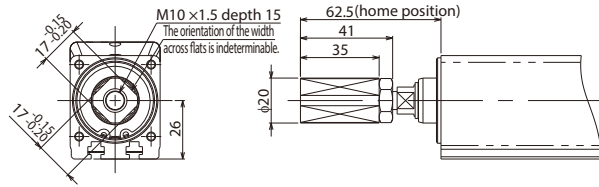

For RCP6(S)-RA6□

Model Number: RCP6-NFA-RA6

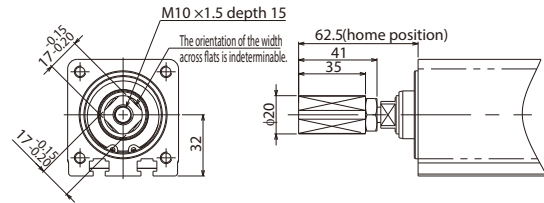

For RCP6(S)-RA7□

Model Number: RCP6-NFA-RA7

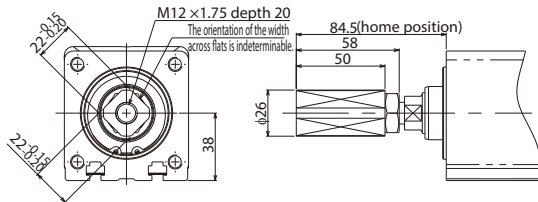

For RCP6(S)-RA8□

Model Number: RCP6-NFA-RA8

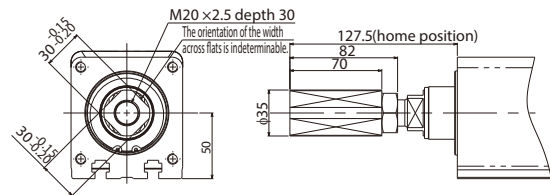

For RCP6(S)-RAA4□

Model Number: RCP6-NFA-RAA4

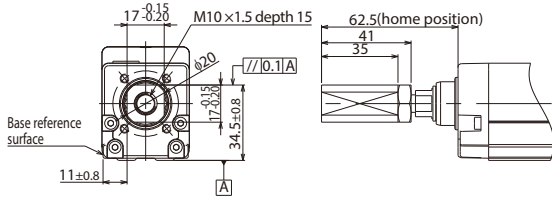

For RCP6(S)-RAA6□

Model Number: RCP6-NFA-RAA6

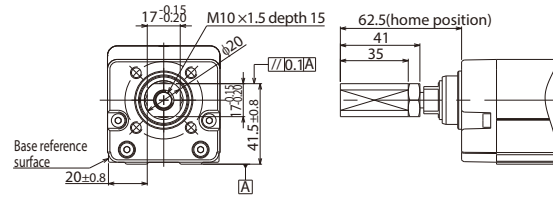

For RCP6(S)-RAA7□

Model Number: RCP6-NFA-RAA7

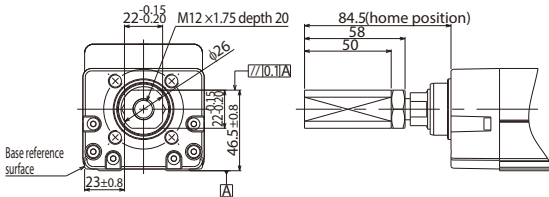

For RCP6(S)-RAA8□

Model Number: RCP6-NFA-RAA8

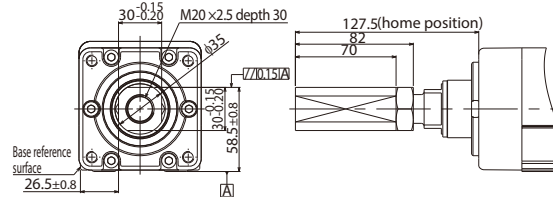

Knuckle Joint

Option Code **NJ** Applicable Models **RCP6(S)-RRA□R**

Description The knuckle joint gives rotational freedom of movement to the rod tip when clevis or trunnion brackets are used.
 * Knuckle joint and clevis brackets for RCP6(S) radial cylinders are furnished separately. The assembly is to be performed by the customer with reference to the mechanical drawings. When making adjustments, we recommend that the parallelism fall within the level mentioned on the mechanical drawings provided. Also, for RCP6(S) Series, please use the knuckle joint and the clevis brackets together as a set.

For RCP6(S)-RRA4R
 Model Number: RCP6-NJ-RRA4R

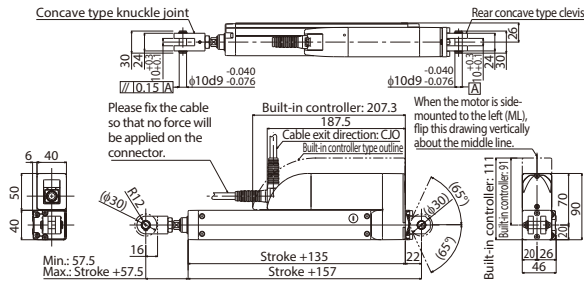

For RCP6(S)-RRA6R
 Model Number: RCP6-NJ-RRA6R

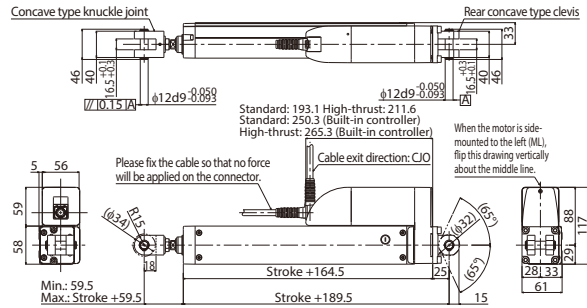

For RCP6(S)-RRA7R
 Model Number: RCP6-NJ-RRA7R

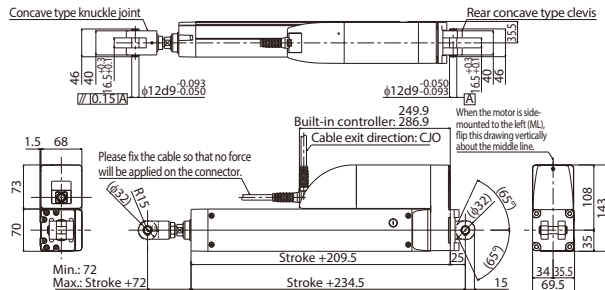

For RCP6(S)-RRA8R
 Model Number: RCP6-NJ-RRA8R

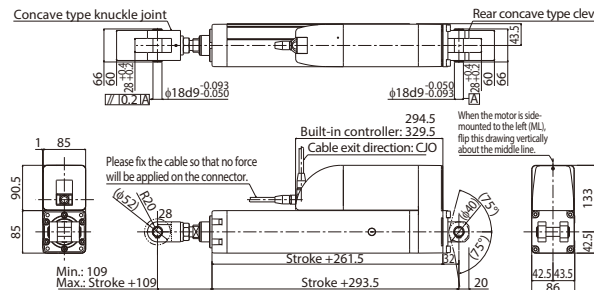

Non-motor End Specification

Option Code **NM** Applicable Models **All Models**

Description The normal home position is set by the slider and rod on the motor side, but there is the option for the home position to be on the other side to accommodate variations in equipment layout, etc. (Please note that changing the home position after the actuator is manufactured and shipped from the factory may require the products to be sent back to IAI for re-setting.)

T-slot Nut Bar

Option Code **NTB / NTBL / NTBR** Applicable Models **RCP6(S)-RA4□/RA6□/RA7□/RA8□/RA10□/RA12□/RA14□/RA16□**

Description T-slot nut bar is a bar-shaped bracket which is to be inserted into the actuator's T-slot. There are tapped mounting holes on the T-slot nut bar. From the motor-side view, NTBL is inserted on the left side, and NTBR is inserted on the right.
 *Rod (RA) type can choose only NTB, while wide radial cylinder (WRA) type can choose either NTBL (for the actuator with its motor side-mounted to the right) or NTBR (for the actuator with its motor side-mounted to the left).
 Note: Mounting holes on the top of the base crossing the nut bar cannot be used for the wide radial cylinder type (WRA).

For RCP6(S)-RA4□
 Model Number: RCP6-NTB-RA4

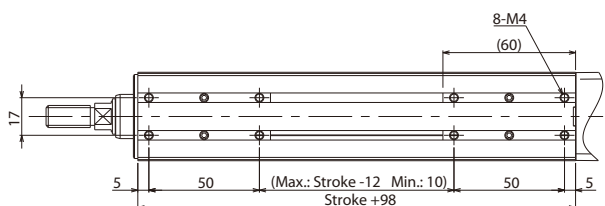

For RCP6(S)-RA6□
 Model Number: RCP6-NTB-RA6

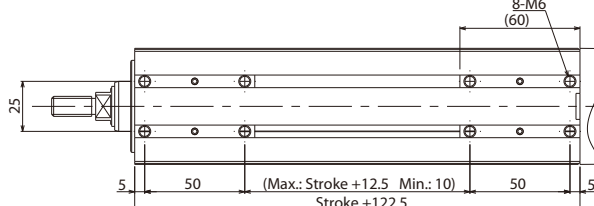

Foreword
 Slider Type
 Wide Slider Type
 Rod Type
 Radial Cylinder
 Wide Radial Cylinder
 Table Type
 Cleanroom Slider
 Cleanroom Wide Slider
 Dust/Splash-Proof Rod
 Dust/Splash-Proof Radial Cylinder
 Dust/Splash-Proof Wide Radial Cylinder
 Options
 Reference Data
 Controller

For RCP6(S)-RA7
 Model Number: RCP6-NTB-RA7

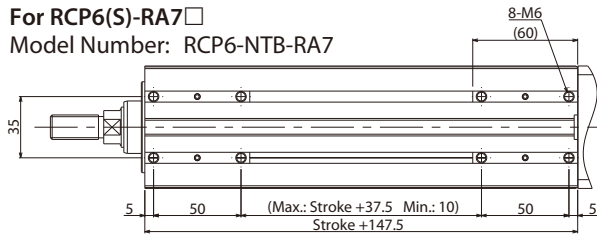

For RCP6(S)-RA8
 Model Number: RCP6-NTB-RA8

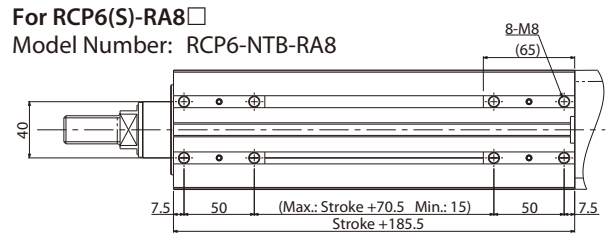

For RCP6(S)-WRA10
 Model Number: RCP6-NTB-WRA10

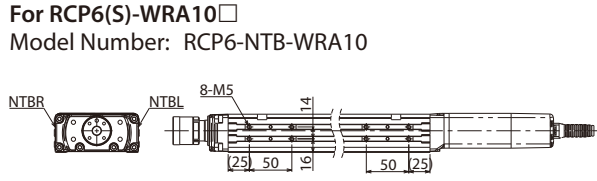

For RCP6(S)-WRA12
 Model Number: RCP6-NTB-WRA12

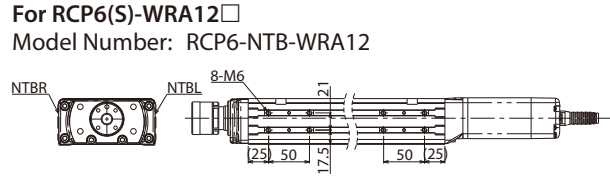

For RCP6(S)-WRA14
 Model Number: RCP6-NTB-WRA14

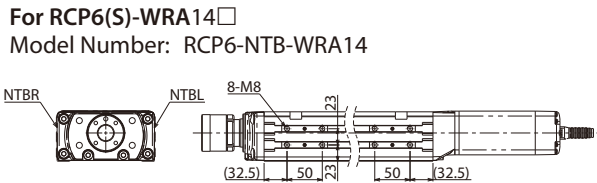

For RCP6(S)-WRA16
 Model Number: RCP6-NTB-WRA16

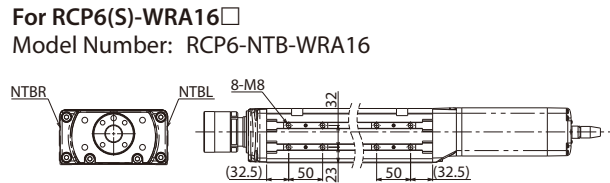

Clevis Bracket

Option Code **QR** Applicable Models **RCP6(S)-RRA**□R

Description A bracket for aligning the cylinder movement when the load installed on the rod tip moves in a direction different from the rod.

Applicable Models	Model Number
RCP6(S)-RRA4R	RCP6-QR-RRA4R
RCP6(S)-RRA6R	RCP6-QR-RRA6R
RCP6(S)-RRA7R	RCP6-QR-RRA7R
RCP6(S)-RRA8R	RCP6-QR-RRA8R

* Knuckle joint and clevis brackets for RCP6(S) radial cylinders are furnished separately. The assembly is to be performed by the customer with reference to the mechanical drawings. When making adjustments, we recommend that the parallelism fall within the level mentioned on the mechanical drawings provided. Also, for RCP6(S) Series, please use the knuckle joint and the clevis brackets together as a set. For mechanical drawings, please refer to the knuckle joint option (NJ) on P.194.

Slider Roller Specification

Option Code **SR** Applicable Models **RCP6(S)-SA**□/WSA□

Description The standard slider structure of the slider type is changed to a roller structure similar to the cleanroom specification. Using a roller specification in the slider part means that the slider cover external view and dimensions are the same as those of the cleanroom type.

Slider Spacer

SS Applicable Models **RCP6(S) -SA7R/SA8R**

This option changes the top of the slider position to be higher than the motor height.

For RCP6(S)-SA7R
 Model Number: RCP6-SS-SA7

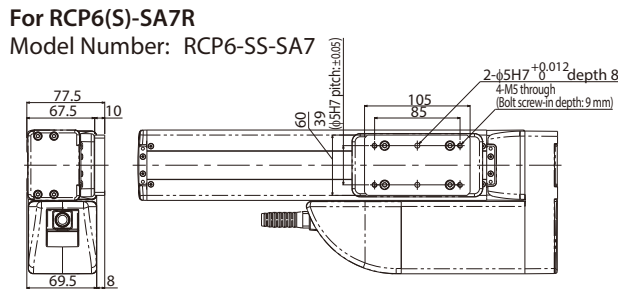

For RCP6(S)-SA8R
 Model Number: RCP6-SS-SA8

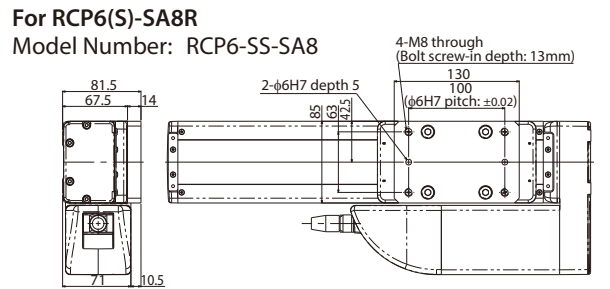

Vacuum joint mounting position opposite

Option Code **VR** Applicable Models **RCP6(S)CR-SA**□/WSA□

Description As standard, the vacuum joint is installed on the left side of the body when seen from the motor side, but this option changes it to the right side (opposite side).

Double Slider Specification

Option Code **W** Applicable Models RCP6(S)/RCP6(S)CR-SA□

Description This option adds a free slider not connected to the ball screw or drive belt.
Using a double slider enables increased moment and overhang load length.
* For the allowable dynamic moment and overhang load length of the double slider, refer to P.248.

Selection Notes for RCP6(S) Series

Warnings When Selecting the Rod Attachment Option

Model	Options				
RCP6	FL	NTBL	NTBR	QR	NJ
RA4R	①	-	-	-	-
RA6R	①	-	-	-	-
RA7R	②	-	-	-	-
RA8R	②	-	-	-	-
RRA4R	③	-	-	⑬	⑬
RRA6R	④	-	-	⑬	⑬
RRA7R	⑤	-	-	⑬	⑬
RRA8R	-	-	-	⑬	⑬
WRA10R	-	⑪	⑫	-	-
WRA12R	-	⑪	⑫	-	-
WRA14R	-	⑪	⑫	-	-
WRA16R	-	⑪	⑫	-	-

Model	Options				
RCP6S	FL	NTBL	NTBR	QR	NJ
RA4R	②	-	-	-	-
RA6R	②	-	-	-	-
RA7R	⑥	-	-	-	-
RA8R	⑥	-	-	-	-
RRA4R	⑦	-	-	⑬	⑬
RRA6R	⑧	-	-	⑬	⑬
RRA7R	⑨	-	-	⑬	⑬
RRA8R	-	-	-	⑬	⑬
WRA10R	-	⑪	⑫	-	-
WRA12R	-	⑪	⑫	-	-
WRA14R	-	⑪	⑫	-	-
WRA16R	-	⑪	⑫	-	-

Be sure to check the following conditions when selecting options.

- ① Cannot be selected for 50ST
- ② Cannot be selected for 50~100ST
- ③ Cannot be selected for 60ST
- ④ Cannot be selected for 65ST
- ⑤ Cannot be selected for 70ST
- ⑥ Cannot be selected for 50~150ST
- ⑦ Cannot be selected for 60~110ST
- ⑧ Cannot be selected for 65~115ST
- ⑨ Cannot be selected for 70~120ST
- ⑩: Always select CJ□ when using 150ST.
- ⑪: Can only be selected when MR is selected.
- ⑫: Can only be selected when ML is selected.
- ⑬: Purchase the clevis (QR) and knuckle joint (NJ) as a set.
The assembly is to be performed by the customer.

- The front flange (FL) rod attachment option cannot be used on side mounting position for RCP6(S)-RRA8R when the following strokes are selected.

• RCP6(S)-RRA8R 50~100mm (Standard/With a brake)

- Please be careful of nearby objects when selecting the flange option for the RCP6(S)-RRA□R models, as there may be some interference between the cable and flange surface for certain strokes. Please also be careful of nearby objects when selecting the tip adapter option (FFA, NFA, KFA) for the RCP6(S)-RRA4R/RRA6R/RRA7R models, there may be some interference between the cable and work piece for certain strokes.

Warnings When Installing the Rod Actuators

When installing the front bracket or flange (optional), please be careful that the actuator does not experience any external force. (External force may cause malfunctions or damaged parts)

If the actuator will experience external force or is being used in conjunction with a Cartesian robot, etc., please use the mounting holes on the base of the actuator to secure it into place.

Even in cases when external force will not be applied, to secure the actuator in place when installed horizontally using a flange or side-mounted motor specification, please use the bracket mounting holes to create a support base as shown in the diagram on the right.

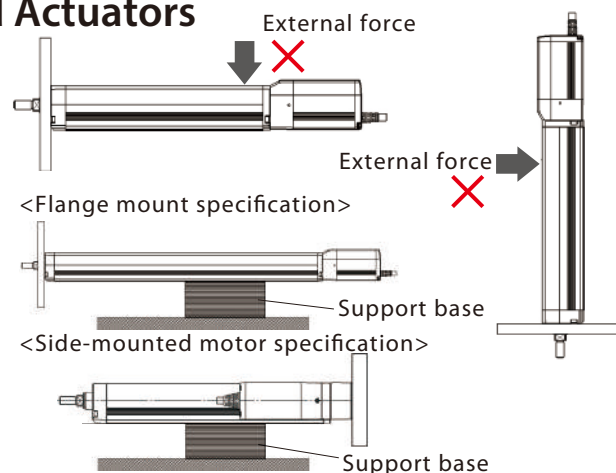

About the Mounting Positions

- While installation in the side and ceiling mount positions are available, this may cause slack or misalignment in the stainless steel sheet. Continuing to use it this way could cause the stainless steel sheet to break. Please inspect it daily and adjust the sheet if any slack or misalignment is found.
- When installing the motor-coupled type vertically, please set the motor on the top if possible. While installing the motor on the bottom will not cause problems in normal operation, long periods of no activity may cause the grease to separate, flow into the motor unit, and cause problems in rare occasions.

Dust/Splash-Proof Specification Options

Changing Actuator Cable Length

Model AC5 / AC10 / AC15

Description Specify when changing the actuator cable (pigtail cable) length. AC5: 5m, AC10: 10m, AC15: 15m.

Brake

Model B

Description When the actuator is mounted vertically, this works as a holding mechanism that prevents the rod from falling and damaging any attachments when the power or servo is turned off.

Cable Exit Direction

Model CJT / CJR / CJL / CJB / CJO

Description This option allows you to change the exit direction of the motor-encoder cable to top, bottom, left, or right.

* Be sure to confirm with the Selection Notes (P.204).

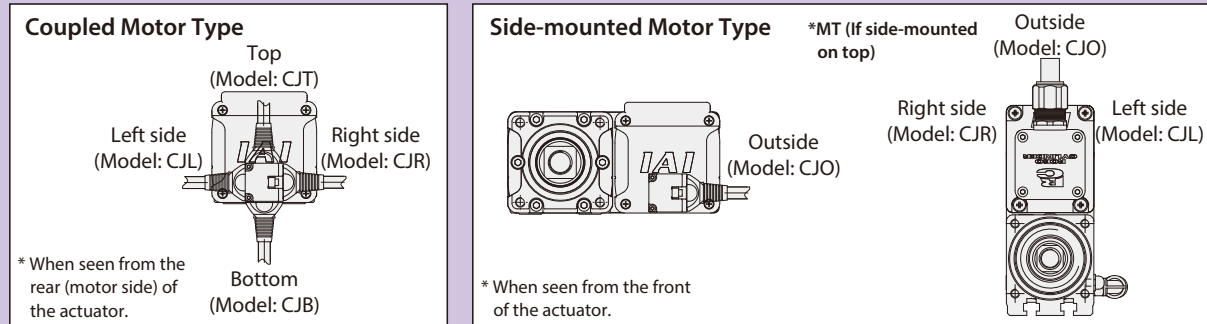

Tip Adapter (Flange)

Model FFA

Description A rod-end tooling adapter with 4 threaded holes.

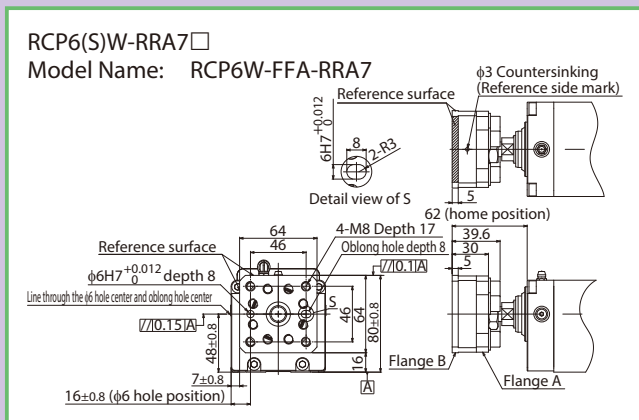
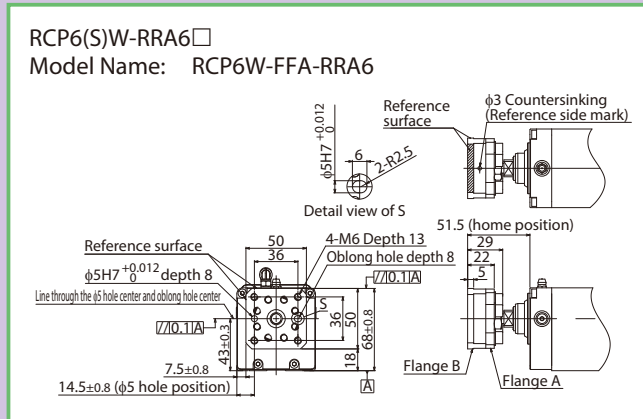
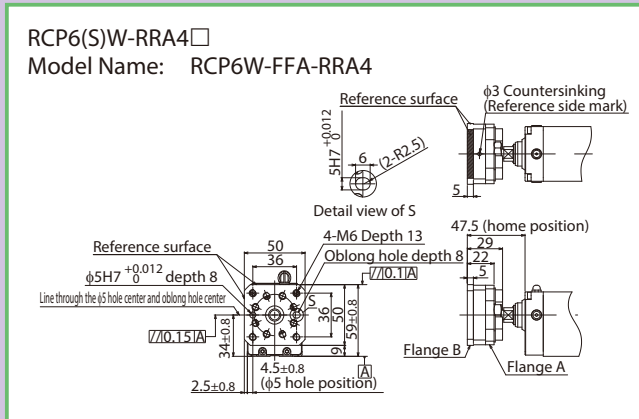

Model FL

Description A bracket that attaches to the actuator body with bolts. * Be sure to confirm with the Selection Notes (P.204).

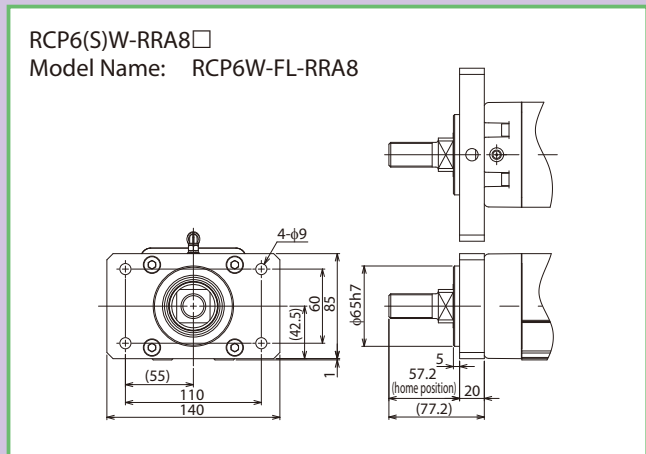
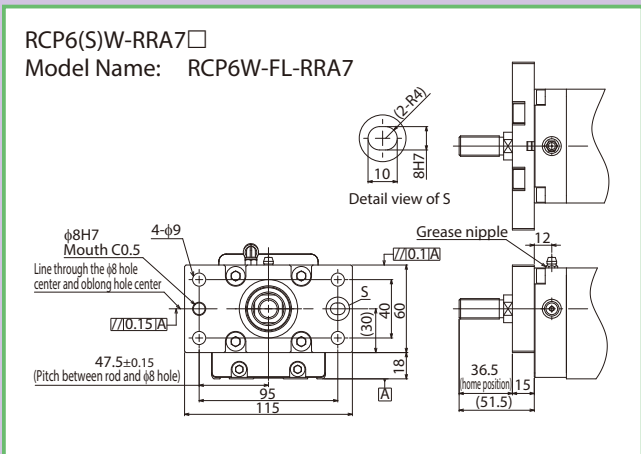
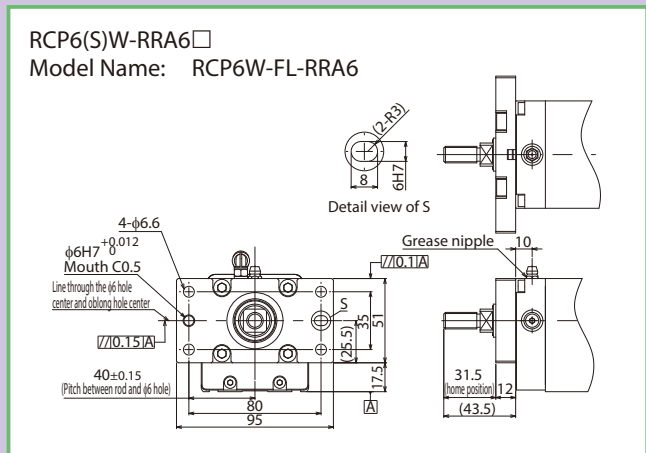
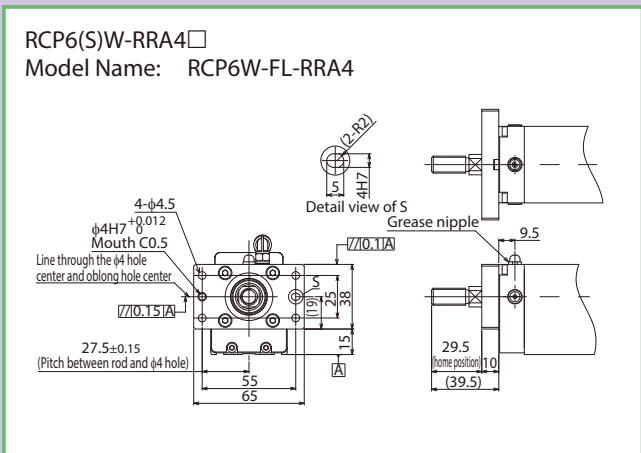
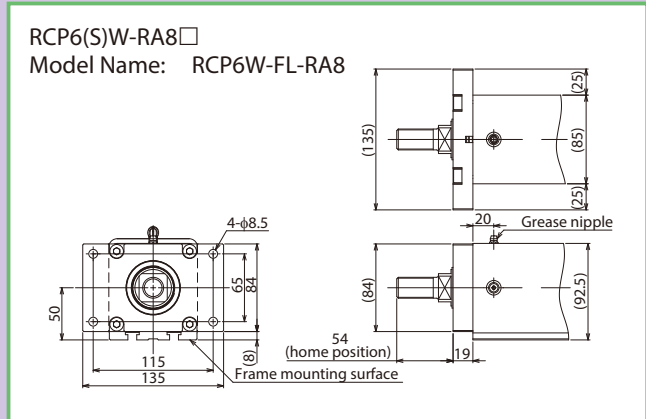
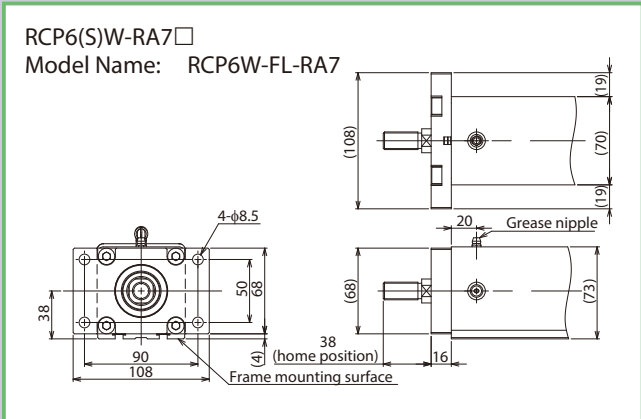
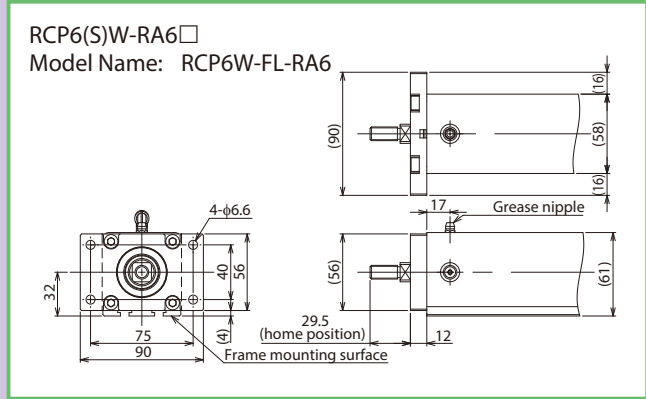
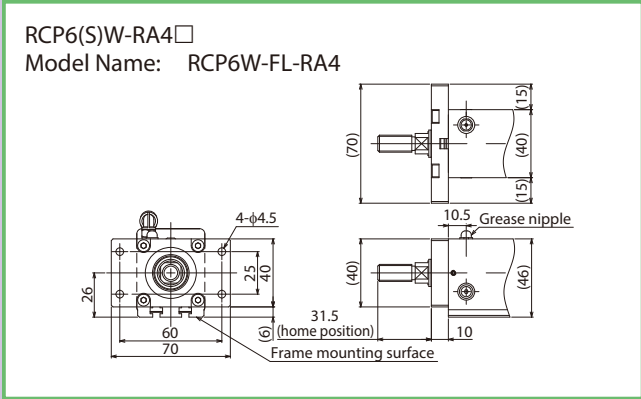

RCP6(S)W-WRA10□
Model Name: RCP6W-FL-WRA10

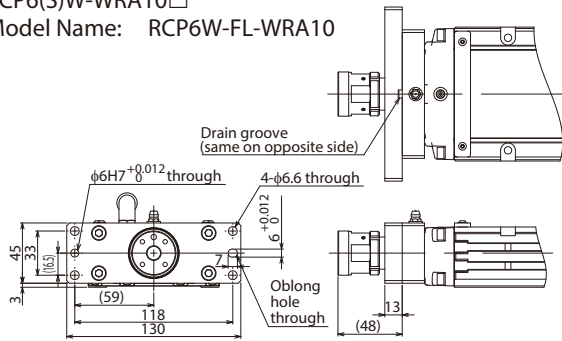

RCP6(S)W-WRA12□
Model Name: RCP6W-FL-WRA12

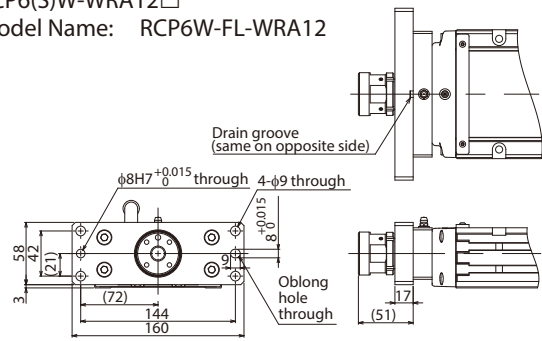

RCP6(S)W-WRA14□
Model Name: RCP6W-FL-WRA14

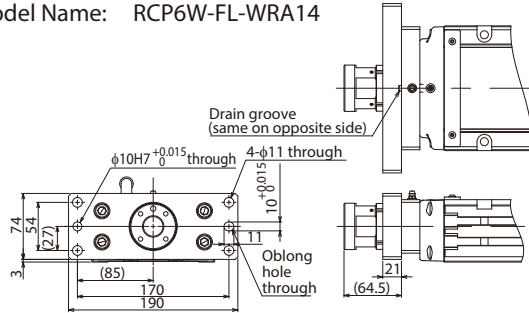

RCP6(S)W-WRA16□
Model Name: RCP6W-FL-WRA16

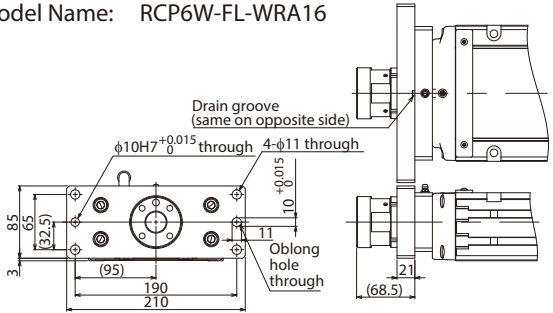

Foot Bracket

Model FT

Description This is a bracket used to fix the actuator with bolts from the top side. (Bolts are tightened from the top, not from the bottom) For slider type actuators, when the moment load is large, please attach the foot brackets on all the mounting holes on the actuator. The actuator body may be twisted or deformed if insufficient number of mounting foot brackets are used. Actuator life could also be shortened.
* Refer to the installation dimensions in the actuator drawing for the installation pitch between the foot brackets.

RCP6(S)W-RA4C
Model Name: RCP6W-FT-RA4C

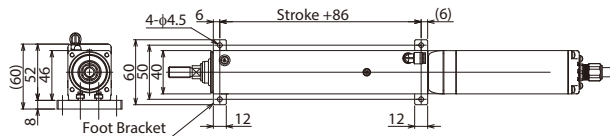

RCP6(S)W-RA6C
Model Name: RCP6W-FT-RA6C

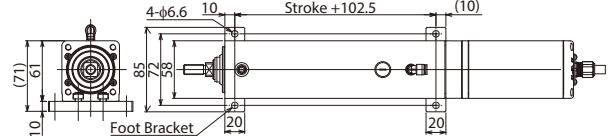

RCP6(S)W-RA7C
Model Name: RCP6W-FT-RA7C

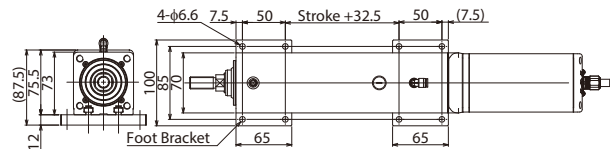

RCP6(S)W-RA8C
Model Name: RCP6W-FT-RA8C

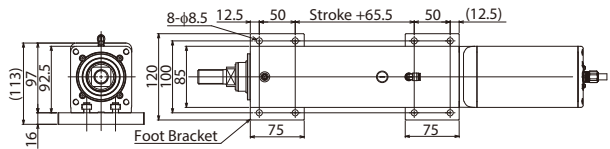

RCP6(S)W-RA4R
Model Name: RCP6W-FT-RA4R-1 (For the motor side-mounted to the top)

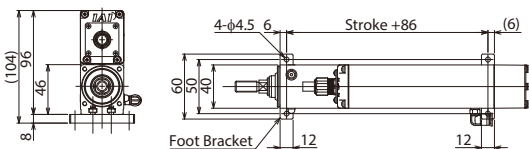

RCP6(S)W-RA6R
Model Name: RCP6W-FT-RA6R-1 (For the motor side-mounted to the top)

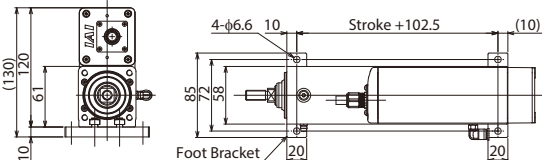

RCP6(S)W-RA7R

Model Name: RCP6W-FT-RA7R-1 (For the motor side-mounted to the top)

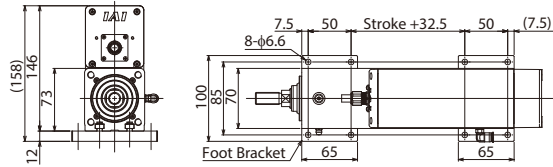

RCP6(S)W-RA8R

Model Name: RCP6W-FT-RA8R-1 (For the motor side-mounted to the top)

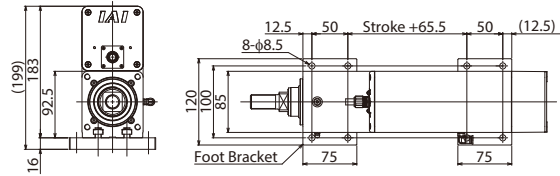

RCP6(S)W-RA4R

Model Name: RCP6W-FT-RA4R-2 (For the motor side-mounted to the right/left)

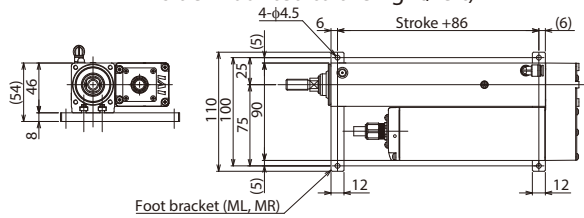

RCP6(S)W-RA6R

Model Name: RCP6W-FT-RA6R-2 (For the motor side-mounted to the right/left)

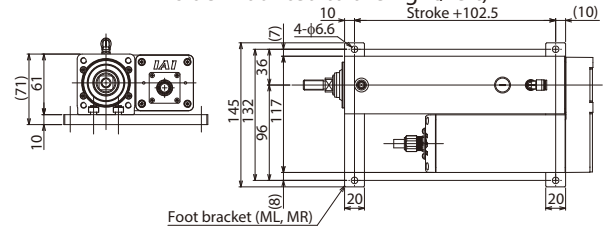

RCP6(S)W-RA7R

Model Name: RCP6W-FT-RA7R-2 (For the motor side-mounted to the right/left)

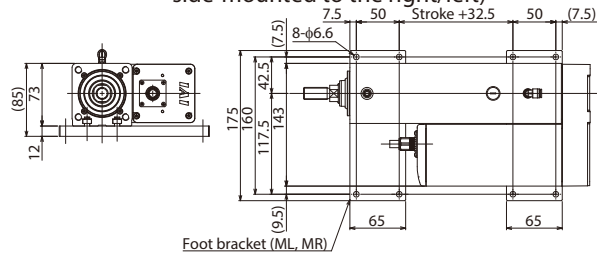

RCP6(S)W-RA8R

Model Name: RCP6W-FT-RA8R-2 (For the motor side-mounted to the right/left)

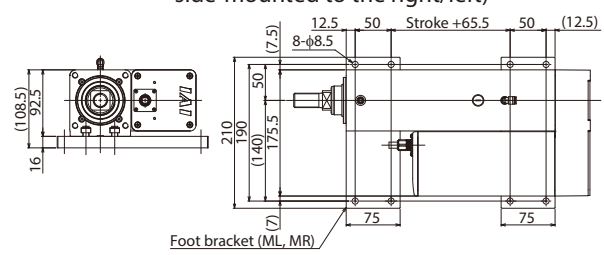

RCP6(S)W-RRA4C

Model Name: RCP6W-FT-RRA4

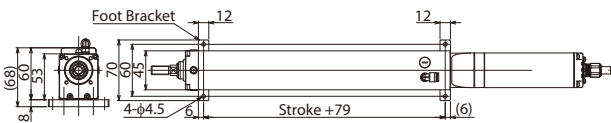

RCP6(S)W-RRA6C

Model Name: RCP6W-FT-RRA6

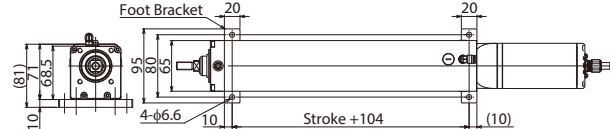

RCP6(S)W-RRA7C

Model Name: RCP6W-FT-RRA7

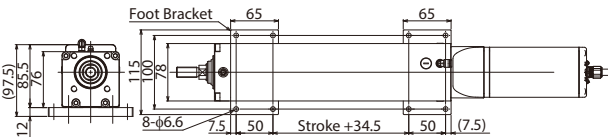

RCP6(S)W-RRA4R

Model Name: RCP6W-FT-RRA4 (For motor side-mounting)

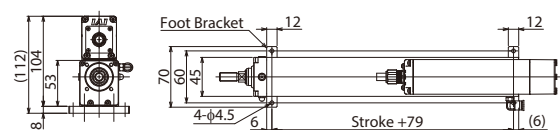

RCP6(S)W-RRA6R

Model Name: RCP6W-FT-RRA6 (For motor side-mounting)

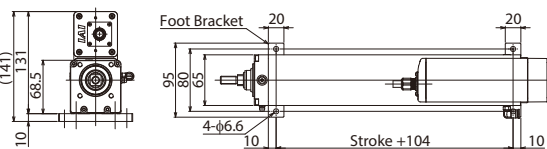

RCP6(S)W-RRA7R

Model Name: RCP6W-FT-RRA7 (For motor side-mounting)

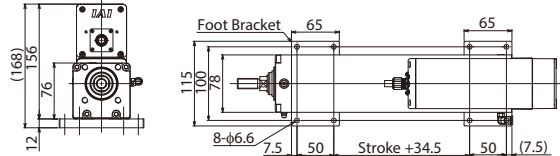

Tip Adapter (Keyway)

Model **KFA**

Description A female threaded tip adapter with a parallel keyway.

RCP6(S)W-RAA4□

Model Name: RCP6W-KFA-RAA4

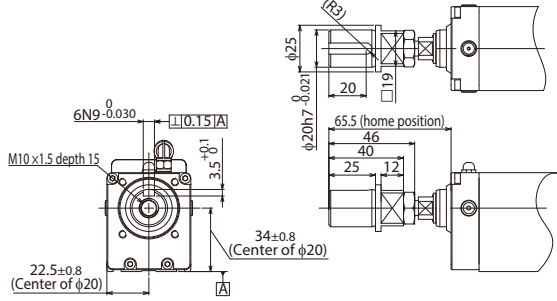

RCP6(S)W-RAA6□

Model Name: RCP6W-KFA-RAA6

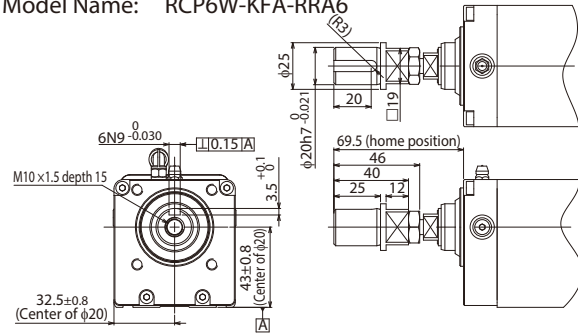

RCP6(S)W-RAA7□

Model Name: RCP6W-KFA-RAA7

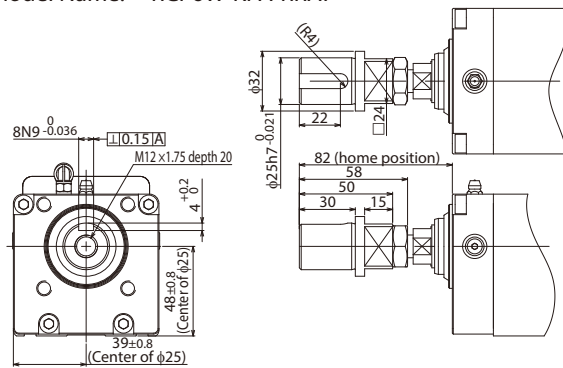

Side-mounted Motor Direction

Model **ML / MR / MT**

Description This allows you to specify the direction of the side-mounted motor type. As viewed from the motor side of the actuator, ML represents left, MR represents right, and MT represents top.

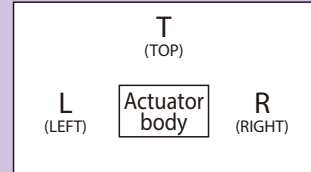

Tip Adapter (Internal Thread)

Model **NFA**

Description A rod-end tooling adapter with 1 threaded hole.

RCP6(S)W-RA4□

Model Name: RCP6W-NFA-RA4

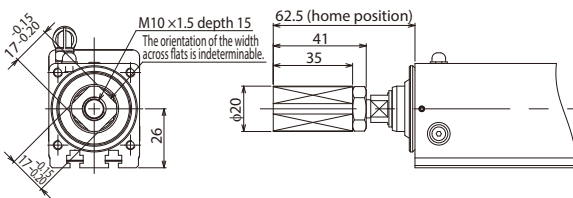

RCP6(S)W-RA6□

Model Name: RCP6W-NFA-RA6

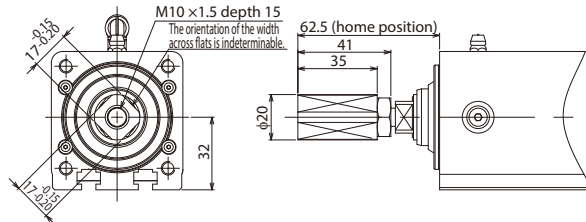

RCP6(S)W-RA7□
Model Name: RCP6W-NFA-RA7

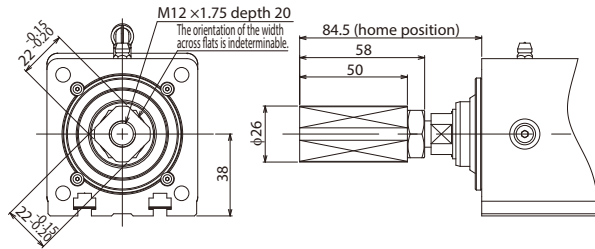

RCP6(S)W-RA8□
Model Name: RCP6W-NFA-RA8

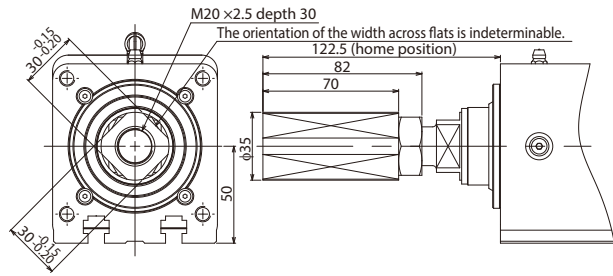

RCP6(S)W-RAA4□
Model Name: RCP6W-NFA-RAA4

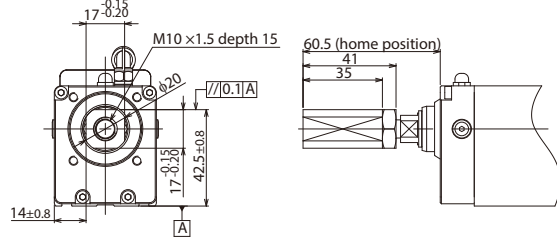

RCP6(S)W-RAA6□
Model Name: RCP6W-NFA-RAA6

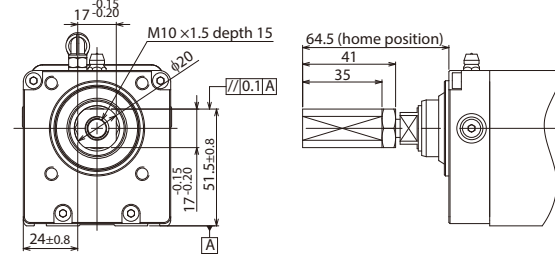

RCP6(S)W-RAA7□
Model Name: RCP6W-NFA-RAA7

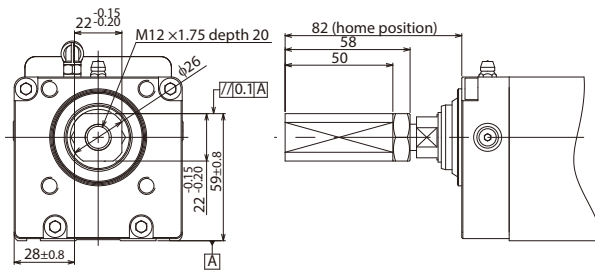

RCP6(S)W-RAA8□
Model Name: RCP6W-NFA-RAA8

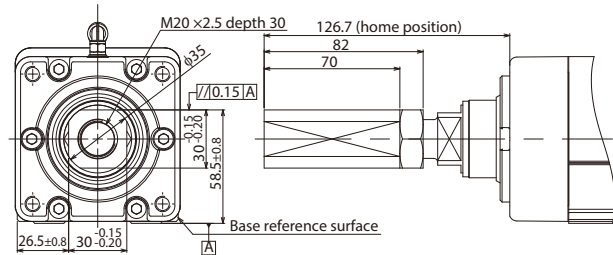

Non-motor End Specification

Model NM

Description The normal home position is set by the slider, rod, and table on the motor side, but there is the option for the home position to be on the other side to accommodate variations in equipment layout, etc. (Please note that changing the home position after the actuator is manufactured and shipped from the factory may require the products to be sent back to IAI for re-setting.)

T-slot Nut Bar

Model NTB / NTBL / NTBR

Description T-slot nut bar is a bar-shaped bracket which is to be inserted into the actuator's T-slot. There are tapped mounting holes on the T-slot nut bar. From the motor-side view, NTBL is inserted on the left side, and NTBR is inserted on the right.

* Only NTB can be selected for Rod type (RA) and Radial Cylinder (RAA4/6/7), while either NTBL (for the actuator with its motor side-mounted to the right) or NTBR (for the actuator with its motor side-mounted to the left) can be selected for wide radial cylinder type (WRA).

Note: Mounting holes on the top of the base crossing the nut bar cannot be used for the wide radial cylinder type (WRA).

Note: NTBL and NTBR for wide radial cylinder (WRA) cannot be installed by the customer after delivery.

RCP6(S)W-RA4□
Model Name: RCP6W-NTB-RA4

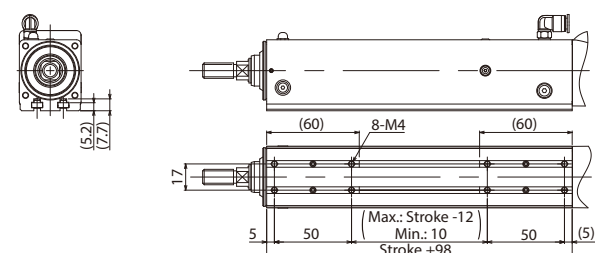

RCP6(S)W-RA6□
Model Name: RCP6W-NTB-RA6

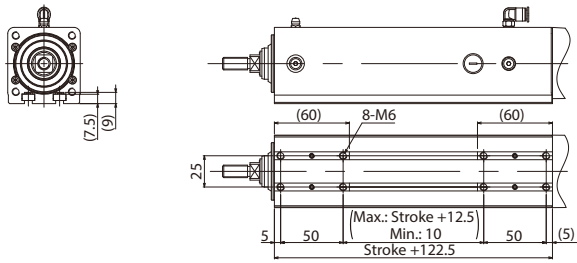

RCP6(S)W-RA7□
Model Name: RCP6W-NTB-RA7

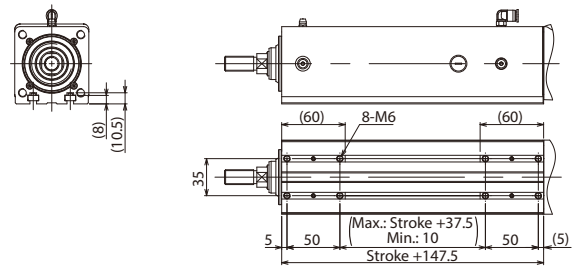

RCP6(S)W-RA8□
Model Name: RCP6W-NTB-RA8

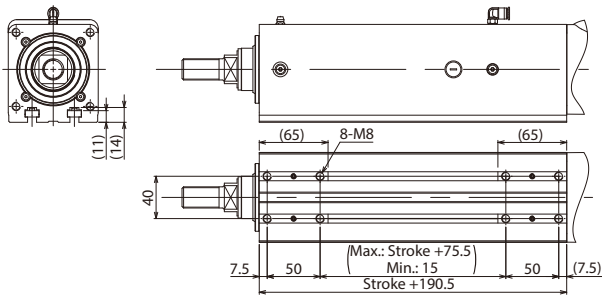

RCP6(S)W-RA4□
Model Name: RCP6W-NTB-RA4

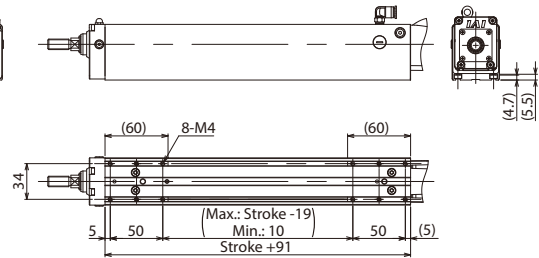

RCP6(S)W-RA6□
Model Name: RCP6W-NTB-RA6

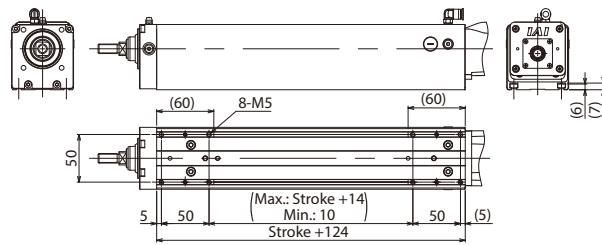

RCP6(S)W-RA7□
Model Name: RCP6W-NTB-RA7

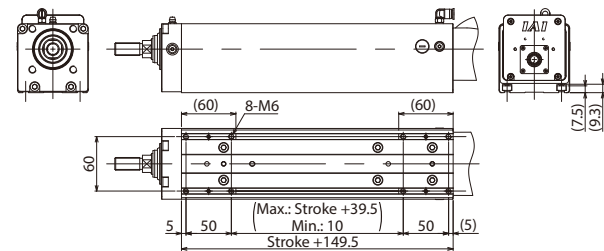

RCP6(S)W-WRA10□
Model Name: RCP6W-NTB-WRA10

* As replacement by the customer is not possible, it cannot be purchased alone.

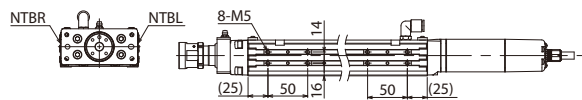

RCP6(S)W-WRA12□
Model Name: RCP6W-NTB-WRA12

* As replacement by the customer is not possible, it cannot be purchased alone.

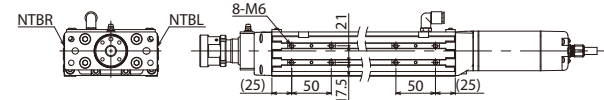

RCP6(S)W-WRA14□
Model Name: RCP6W-NTB-WRA14

* As replacement by the customer is not possible, it cannot be purchased alone.

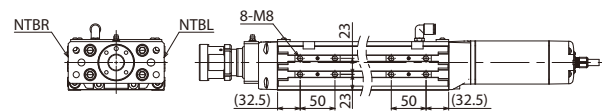

RCP6(S)W-WRA16□
Model Name: RCP6W-NTB-WRA16

* As replacement by the customer is not possible, it cannot be purchased alone.

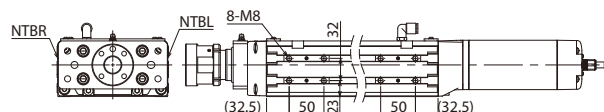

■ Cautions When Selecting the Rod Attachment Option

Model	Options							
RCP6W	CJB	CJL	CJO	CJR	CJT	FL	NTBL	NTBR
RA4R	①	②	○	②	①	③④	—	—
RA6R	①	②	○	②	①	③④	—	—
RA7R	①	②	○	②	①	③④	—	—
RA8R	①	②	○	②	①	③④	—	—
RRA4R	—	○	○	○	—	③④	—	—
RRA6R	—	○	○	○	—	③④	—	—
RRA7R	—	○	○	○	—	③④	—	—
RRA8R	○	—	○	—	○	③④	—	—
WRA10R	○	—	○	—	○	③④	⑤	⑥
WRA12R	○	—	○	—	○	③④	⑤	⑥
WRA14R	○	—	○	—	○	③④	⑤	⑥
WRA16R	○	—	○	—	○	③④	⑤	⑥

Be sure to check the following conditions when selecting options.

- ① : Can be selected when ML or MR is selected.
- ② : Can be selected when MT is selected.
- ③ : Cannot be selected for 50ST.
- ④ : Always select CJ□ when using 100ST.
- ⑤ : Can only be selected when MR is selected.
- ⑥ : Can only be selected when ML is selected.

Note: NTBL and NTBR cannot be installed by the customer after delivery.

Model	Options							
RCP6SW	CJB	CJL	CJO	CJR	CJT	FL	NTBL	NTBR
RA4R	①	②	○	②	①	③④	—	—
RA6R	①	②	○	②	①	③④	—	—
RA7R	①	②	○	②	①	③④	—	—
RA8R	①	②	○	②	①	③④	—	—
RRA4R	—	○	○	○	—	③④	—	—
RRA6R	—	○	○	○	—	③④	—	—
RRA7R	—	○	○	○	—	③④	—	—
RRA8R	○	—	○	—	○	③④	—	—
WRA10R	○	—	○	—	○	③④	⑤	⑥
WRA12R	○	—	○	—	○	③④	⑤	⑥
WRA14R	○	—	○	—	○	③④	⑤	⑥
WRA16R	○	—	○	—	○	③④	⑤	⑥

Be sure to check the following conditions when selecting options.

- ① : Can be selected when ML or MR is selected.
- ② : Can be selected when MT is selected.
- ③ : Cannot be selected for 50ST or 100ST.
- ④ : Always select CJ□ when using 150ST.
- ⑤ : Can only be selected when MR is selected.
- ⑥ : Can only be selected when ML is selected.

- The front flange (FL) rod attachment option cannot be used on side mounting position for RCP6(S)W-RRA8R when the following strokes are selected.

• RCP6(S)W-RRA8R Stroke 50~100 (standard/with brake)

- Please be careful of nearby objects when selecting the front flange (FL) option for the RCP6(S)W-RRA□R models, as there may be some interference between the cable and flange surface for certain strokes. Please also be careful of nearby objects when selecting the tip adapter option (FFA, NFA, KFA) for the RCP6(S)W-RRA4R/RRA6R/RRA7R models, as there may be some interference between the cable and work piece for certain strokes.

■ Notes When Installing the Rod Type

When installing the front bracket or flange (optional), please be careful that the actuator does not experience any external force. (External force may cause malfunctions or damaged parts)
If the actuator will experience external force or is being used in conjunction with a Cartesian robot, etc., please use the mounting holes on the base of the actuator to secure it into place.

Even in cases when external force will not be applied, to secure the actuator in place when mounted horizontally using a flange or side-mounted motor specification, please use the bracket mounting holes to create a support base as shown in the diagram on the right.

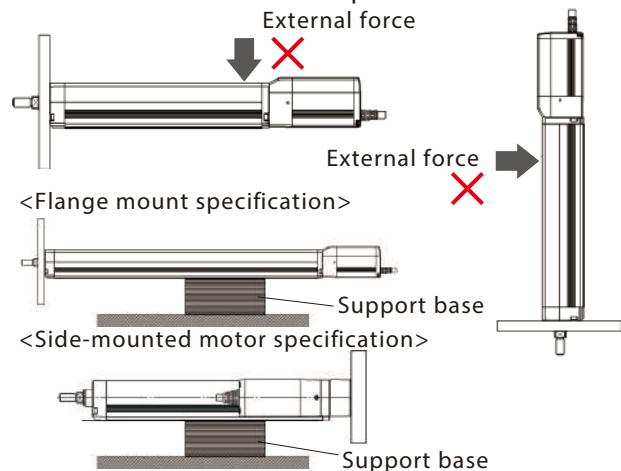

■ About the Mounting Orientation

- When mounting the motor coupled type vertically, please set the motor on the top if possible. While installing the motor on the bottom will not cause problems during normal operation, long periods of inactivity may cause the grease to separate, flow into the motor unit, and cause problems in rare occasions.

Correlation Diagrams of Push Force and Current Limit

RCP6 Series

Slider Type/Rod Type * Includes RCP6CR/RCP6W

Push force can be achieved only during push mode and speed is limited below 20mm/s depending on the model. See manual for details. In the push-motion operation, the push force can be changed by changing the current force of the controller to be between 20% (30%)-70%. The maximum push force will vary depending on the model, so please refer to the graphs below and on the following page, and select one based on the needed push force for your intended use.

When performing the push-motion operation with the slider type, please limit the push current in order that the reactive moment caused by the push force does not exceed the dynamic allowable moment (M_a , M_b) specified in the catalog (It should be 80% or less of the dynamic allowable moment for the slider type). Please refer to the figures below, which show the working point of the guide moment, for help with calculating the moment. This can be done by considering the offset of the push force application position. Please note that if excessive force which exceeds the dynamic allowable moment is applied, it may damage the guide and shorten its service life. Please keep this in mind and select a push current that is safely within its limits.

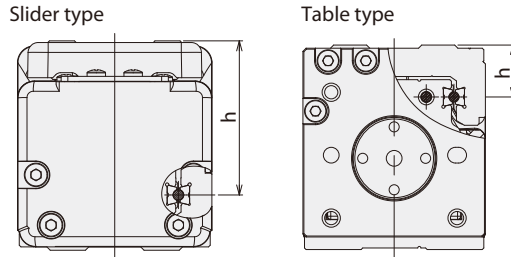

Working point of the guide moment

h dimension			
	Slider type	Table type	
SA4	36	TA4	12
SA6	46	TA6	16.5
SA7	48	TA7	19.5
SA8	45.5		
WSA10	26.5		
WSA12	32		
WSA14	36		
WSA16	38.5		

* Unit: mm

Calculation example)

If push-motion operation is performed with an RCP6-SA7C by applying 200N at the position shown to the right, the moment received by the guide, or M_a , is calculated as:

$$M_a = (48+50) \times 200 = 19,600 \text{ (N}\cdot\text{mm)}$$

$$= 19.6 \text{ (N}\cdot\text{m)}$$

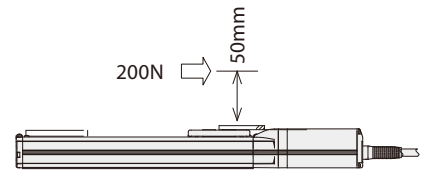

Since the dynamic allowable moment of the SA7C is $M_a = 44.7 \text{ (N}\cdot\text{m)}$, so $44.7 \times 0.8 = 35.76 > 19.6$, this is an acceptable selection.

Also, should an M_b moment occur due to the push operation, calculate the moment from the overhang and ensure that it is within range of the dynamic allowable moment.

Correlation Diagrams of Push Force and Current Limit

* The graphs below are only a reference, and the graphs may vary slightly from the actual.

SA4/RA4/RRA4/TA4 Type

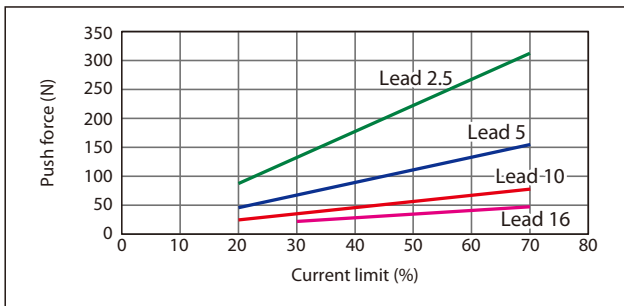

* RCP6W push motion is from 30% or more of the current limit.

SA6/RA6/RRA6/TA6 Type

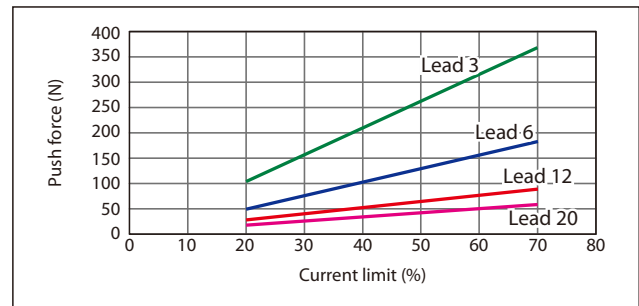

* RCP6W push motion is from 30% or more of the current limit.

SA7/TA7/WSA14 Type

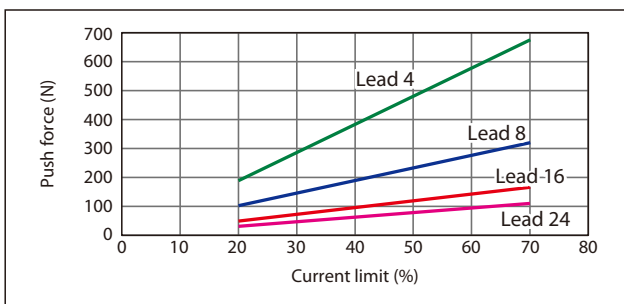

SA8 Type

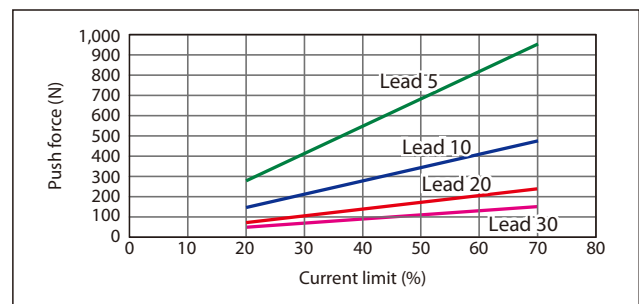

WSA10/WRA10 Type

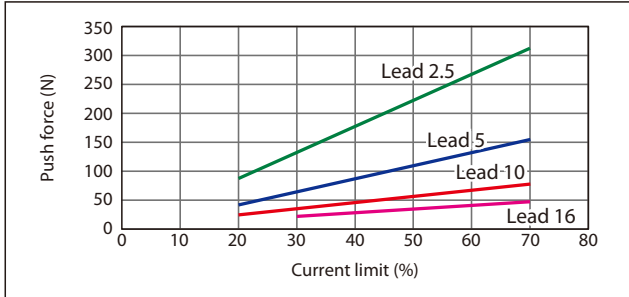

* RCP6W push motion is from 30% or more of the current limit.

WSA12/WRA12 Type

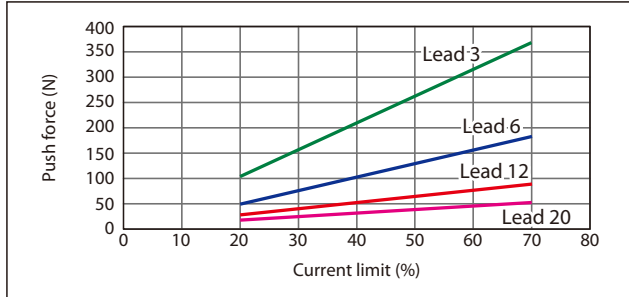

* RCP6W push motion is from 30% or more of the current limit.

RA7/RRA7/WRA14 Type

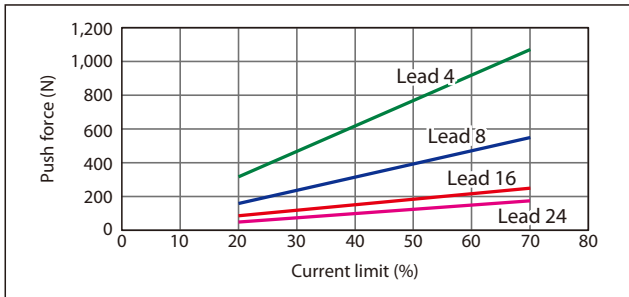

* RCP6W push motion is from 30% or more of the current limit.

RA8/RRA8/WRA16 Type

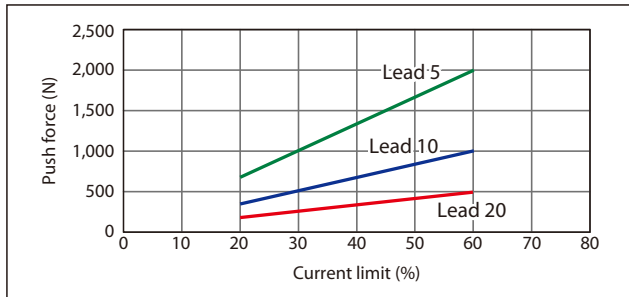

* RCP6W push motion is from 30% or more of the current limit.

WSA16 Type

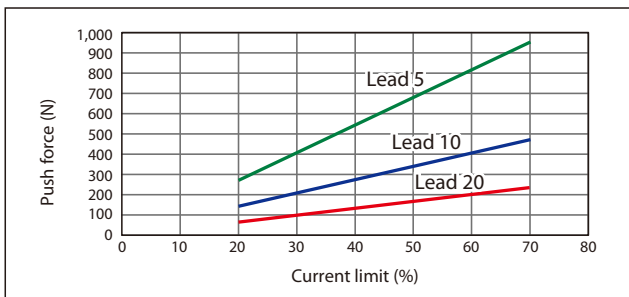

Vertical Payload and Service Life * The graph below is only a reference, and the graph may vary slightly from the actual.

When using RCP6(S)-RA8, RRA8, WSA16 (lead 5 only), WRA16 (lead 5 only), RCP6(S)W-RA8, RRA8, WSA16 (lead 5 only), WRA16 (lead 5 only) vertically, their service life will vary greatly depending on the payload. Please check the following graph.

RA8/RRA8/WSA16/WRA16 Type

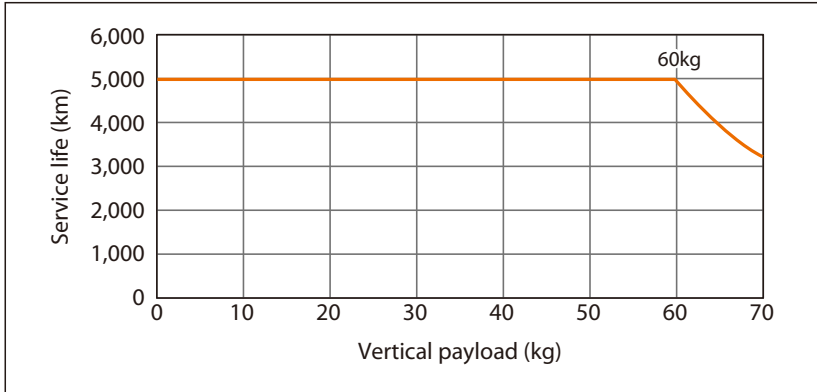

Tables of Payload by Speed/Acceleration

The tables below shows the maximum payload in each acceleration/deceleration for different models. Please select a model that satisfies the operational conditions you desire.

For the MCON-C/LC controller, high-output enabled operation is only available if "high-output setting" is selected as an option.

For the double slider payload, refer to P.248.

RCP6 Series

Slider Type Motor Coupling Specification

High-output Setting Enabled

* RCP6CR is the same.

■ RCP6/RCP6S-SA4C

Lead 16

Orientation	Horizontal						Vertical		
	Acceleration (G)								
Speed (mm/s)	0.1	0.3	0.5	0.7	1	0.1	0.3	0.5	
0	7	7	5	5	4.5	1.5	1.5	1.5	
140	7	7	5	5	4.5	1.5	1.5	1.5	
280	7	7	5	5	4.5	1.5	1.5	1.5	
420	7	7	5	5	4.5	1.5	1.5	1.5	
560	7	7	5	5	4.5	1.5	1.5	1.5	
700	6	6	5	4.5	4	1.5	1.5	1.5	
840	6	4	4	3.5		1	1		
980	4	4	3	2.5		1	1		
1,120		2.5	2	1.5		1	0.75		
1,260		2	1.5	1			0.5		

Lead 10

Orientation	Horizontal						Vertical		
	Acceleration (G)								
Speed (mm/s)	0.1	0.3	0.5	0.7	1	0.1	0.3	0.5	
0	12	12	12	10	9	3	3	3	
85	12	12	12	10	9	3	3	3	
175	12	12	12	10	9	3	3	3	
260	12	12	12	10	9	3	3	3	
350	12	12	12	10	9	3	3	3	
435	12	12	12	10	8	2.5	2.5	2.5	
525	12	12	10	8	7	2.25	2.25	2.25	
610	12	10	8	6	5	2.25	2.25	2.25	
700		8	6	4	3		2	1.75	
785		7	4	3	3		1.5	1.25	

Lead 5

Orientation	Horizontal						Vertical		
	Acceleration (G)								
Speed (mm/s)	0.1	0.3	0.5	0.7	1	0.1	0.3	0.5	
0	14	14	14	14	14	5.5	5.5	5.5	
40	14	14	14	14	14	5.5	5.5	5.5	
85	14	14	14	14	14	5.5	5.5	5.5	
130	14	14	14	14	14	5.5	5.5	5.5	
175	14	14	14	14	14	5.5	5.5	5.5	
215	14	14	14	14	14	5.5	5.5	5.5	
260	14	14	14	14	13	5.5	5.5	5.5	
305	14	14	14	14	12	5	5	5	
350	14	12	12	12	10	4.5	4.5	4.5	
390	14	10	10	10	10	4	4	3.5	

Lead 2.5

Orientation	Horizontal						Vertical		
	Acceleration (G)								
Speed (mm/s)	0.1	0.3	0.5	0.7	1	0.1	0.3	0.5	
0	18	18	18	18	18	12	12	12	
20	18	18	18	18	18	12	12	12	
40	18	18	18	18	18	12	12	12	
65	18	18	18	18	18	12	12	12	
85	18	18	18	18	18	12	12	12	
105	18	18	18	18	18	12	12	12	
130	18	18	18	18	18	11	11	11	
150	18	18	18	18	18	10	10	10	
175	18	18	18	18	18	9	9	9	
195	18	18	18	18	18	8	8	8	

■ RCP6/RCP6S-SA6C

Lead 20

Orientation	Horizontal						Vertical		
	Acceleration (G)								
Speed (mm/s)	0.1	0.3	0.5	0.7	1	0.1	0.3	0.5	
0	15	15	10	8	7	1	1	1	
160	15	15	10	8	7	1	1	1	
320	15	12	10	8	6	1	1	1	
480	12	12	9	8	6	1	1	1	
640	12	12	8	6	5	1	1	1	
800	10	10	6.5	4.5	3	1	1	1	
960		8	5	3.5	2		1	1	
1,120		6.5	3	2	1.5		0.5	0.5	
1,280		1	1	1				0.5	
1,440			1	0.5					

Lead 12

Orientation	Horizontal						Vertical		
	Acceleration (G)								
Speed (mm/s)	0.1	0.3	0.5	0.7	1	0.1	0.3	0.5	
0	28	26	18	16	14	2.5	2.5	2.5	
80	28	26	18	16	14	2.5	2.5	2.5	
200	28	26	18	16	14	2.5	2.5	2.5	
320	28	26	18	14	12	2.5	2.5	2.5	
440	28	26	18	12	10	2.5	2.5	2.5	
560	28	20	12	8	7	2.5	2.5	2.5	
680	20	15	9	5	4	2.5	2.5	2.5	
800	15	9	5	2	1	2	2	1	
900		5	3	1	1		0.5	0.5	

Lead 6

Orientation	Horizontal						Vertical		
	Acceleration (G)								
Speed (mm/s)	0.1	0.3	0.5	0.7	1	0.1	0.3	0.5	
0	32	32	26	24	20	6	6	6	
40	32	32	26	24	20	6	6	6	
100	32	32	26	24	20	6	6	6	
160	32	32	26	24	20	6	6	6	
220	32	32	26	24	20	6	6	6	
280	32	32	26	24	15	6	6	5.5	
340	32	32	20	18	12	6	5	4.5	
400	32	22	12	11	8	4.5	3.5	3.5	
450	26	15	8	6	4	3.5	2	2	

Lead 3

Orientation	Horizontal						Vertical		
	Acceleration (G)								
Speed (mm/s)	0.1	0.3	0.5	0.7	1	0.1	0.3	0.5	
0	40	40	35	35	35	16	16	16	
20	40	40	35	35	35	16	16	16	
50	40	40	35	35	35	16	16	16	
80	40	40	35	35	30	16	16	16	
110	40	40	35	35	30	16	16	16	
140	40	40	35	35	28	16	15	15	
170	40	40	32	32	24	14	13	12	
200	40	35	28	25	20	11	10	9	
225	40	28	20	18	14	9	8		

■ RCP6/RCP6S-SA7C

Lead 24

Orientation	Horizontal						Vertical		
	Acceleration (G)								
Speed (mm/s)	0.1	0.3	0.5	0.7	1	0.1	0.3	0.5	
0	37	37	22	16	14	3	3	3	
200	37	37	22	16	14	3	3	3	
420	37	34	20	16	14	3	3	3	
640	37	20	15	10	9	3	3	3	
860		12	10	7	4		3	2.5	
1,080		8	4.5	4	2		2	1	
1,200		5.5	2	2	1		1		

Lead 16

Orientation	Horizontal						Vertical		
	Acceleration (G)								
Speed (mm/s)	0.1	0.3	0.5	0.7	1	0.1	0.3	0.5	
0	46	46	35	28	27	8	8	8	
140	46	46	35	28	27	8	8	8	
280	46	46	35	25	24	8	8	8	
420	46	34	25	15	10	6	5	4.5	
560		35	20	15	10	6	5	4	
700		20	15	10	5	3	4	3	
840		9	4	2			1		
980		4							

Lead 8

Orientation	Horizontal						Vertical		
	Acceleration (G)								
Speed (mm/s)	0.1	0.3	0.5	0.7	1	0.1	0.3	0.5	
0	51	51	45	40	40	16	16	16	
70	51	51	45	40	40	16	16	16	
140	51	51	40	38	35	16	16	16	
210	51	51	35	30	24	11	10	9.5	
280	51	40	28	20	15	9	8	7	
350	51	30	9	4		7	5	4	
420	40	7				5	2		
490	20					2			

Lead 4

Orientation	Horizontal						Vertical		
	Acceleration (G)								
Speed (mm/s)	0.1	0.3	0.5	0.7	1	0.1	0.3	0.5	
0	55	55	45	40	40	25	25	25	
35	55	55	45	40	40	25	25	25	
70	55	55	45	40	40	25	25	25	
105	55	55	45	40	35	22	20	19	
140	55	45	35	30	25	16	14	12	
175	55	30	18			11	9	7.5	
210	45	8				8			
245	35								

■ RCP6/RCP6S-SA8C

Lead 30

Orientation	Horizontal						Vertical		
	Acceleration (G)								
Speed (mm/s)	0.1	0.3	0.5	0.7	1	0.1	0.3	0.5	
0	28	26	20	16	13	3	3	3	
100	28	26	20	16	13	3	3	3	
200	28	26	20	16	13	2	2	2	
400	28	24	18	15	11	1.5	1.5	1.5	
650	21	18	15	12	8	1	1	1	
850		14	10	7	5		1	1	
1,000		8	6	3	2				
1,200		4	2	1	0.5				

Lead 20

Orientation	Horizontal						Vertical		
	Acceleration (G)								
Speed (mm/s)	0.1	0.3	0.5	0.7	1	0.1	0.3	0.5	
0	51	45	40	35	4	4	4	4	
50	60	51	45	40	32	4	4	4	
100	60	51	45	33	30	4	4	4	
200	60	51	45	33	25	4	4	4	
300	60	51	40	30	23	4	4	4	
400	50	35	30	23	20	2	2	2	
650	50	20	1						

* RCP6CR is the same.

High-output Setting Disabled

■ RCP6/RCP6S-SA4C

Lead 16

Orientation	Horizontal					Vertical				
	Acceleration (G)									
Speed (mm/s)	0.1	0.3	0.5	0.7	1	0.1	0.3	0.5	0.7	1
0	4			3.5						1
140	4			3.5						1
280	4			3.5						1
420	4			3						0.75
560	3.5			2.5						0.75
700	3			2						0.5
840	2.5			1.5						0.5

Lead 10

Orientation	Horizontal					Vertical				
	Acceleration (G)									
Speed (mm/s)	0.1	0.3	0.5	0.7	1	0.1	0.3	0.5	0.7	1
0	10			8						2.25
85	10			8						2.25
175	10			8						2.25
260	9			6						2
350	7			5						2
435	6			4						1.5
525	5			3						1

Lead 5

Orientation	Horizontal					Vertical				
	Acceleration (G)									
Speed (mm/s)	0.1	0.3	0.5	0.7	1	0.1	0.3	0.5	0.7	1
0	12			10						4.5
40	12			10						4.5
85	12			10						4.5
130	10			9						4
175	10			8						4
215	9			7						4
260	8			6						2.5

Lead 2.5

Orientation	Horizontal					Vertical				
	Acceleration (G)									
Speed (mm/s)	0.1	0.3	0.5	0.7	1	0.1	0.3	0.5	0.7	1
0	12			12						9
20	12			12						9
40	12			12						9
65	12			11						8
85	11			10						8
105	10			9						8
130	10			8						5

■ RCP6/RCP6S-SA6C

Lead 20

Orientation	Horizontal					Vertical				
	Acceleration (G)									
Speed (mm/s)	0.1	0.3	0.5	0.7	1	0.1	0.3	0.5	0.7	1
0	8			5						0.75
160	8			5						0.75
320	8			5						0.75
480	8			4						0.75
640	6			3						0.75
800	4			1.5						0.75
960	2			0.5						0.5

Lead 12

Orientation	Horizontal					Vertical				
	Acceleration (G)									
Speed (mm/s)	0.1	0.3	0.5	0.7	1	0.1	0.3	0.5	0.7	1
0	14			10						2
80	14			10						2
200	14			10						2
320	14			10						2
440	11			7						1.5
560	7			2.5						1
680	4			1						0.5

Lead 6

Orientation	Horizontal					Vertical				
	Acceleration (G)									
Speed (mm/s)	0.1	0.3	0.5	0.7	1	0.1	0.3	0.5	0.7	1
0	20			14						5
40	20			14						5
100	20			14						5
160	20			14						5
220	16			14						4
280	13			7						2.5
340	10			1						1

Lead 3

Orientation	Horizontal					Vertical				
	Acceleration (G)									
Speed (mm/s)	0.1	0.3	0.5	0.7	1	0.1	0.3	0.5	0.7	1
0	25			22						10
20	25			22						10
50	25			22						10
80	25			22						10
110	20			14						8
140	15			11						5
170	11			9						2

■ RCP6/RCP6S-SA7C

Lead 24

Orientation	Horizontal					Vertical				
	Acceleration (G)									
Speed (mm/s)	0.1	0.3	0.5	0.7	1	0.1	0.3	0.5	0.7	1
0	18			10						2
200	18			10						2
420	18			10						2
640	10			2						1
800	5			0.5						0.5

Lead 16

Orientation	Horizontal					Vertical				
	Acceleration (G)									
Speed (mm/s)	0.1	0.3	0.5	0.7	1	0.1	0.3	0.5	0.7	1
0	35			20						5
140	35			20						5
280	25			12						3
420	15			6						1.5
560	7			0.5						0.5

Lead 8

Orientation	Horizontal					Vertical				
	Acceleration (G)									
Speed (mm/s)	0.1	0.3	0.5	0.7	1	0.1	0.3	0.5	0.7	1
0	40			25						10
70	40			25						10
140	40			25						7
210	25			14						4
280	10			1						1.5

Lead 4

Orientation	Horizontal					Vertical				
	Acceleration (G)									
Speed (mm/s)	0.1	0.3	0.5	0.7	1	0.1	0.3	0.5	0.7	1
0	40			30						15
35	40			30						15
70	40			30						15
105	40			30						8
140	15			6						2

Tables of Payload by Speed/Acceleration

RCP6 Series

Slider Type Side-Mounted Motor Specification

High-output Setting Enabled

■ RCP6/RCP6S-SA4R

Lead 16

Orientation	Horizontal		Vertical					
	Acceleration (G)							
	0.1	0.3	0.5	0.7	1	0.1	0.3	0.5
Speed (mm/s)								
0	7	7	5	4.5	4.5	1.5	1.5	1.5
140	7	7	5	4.5	4.5	1.5	1.5	1.5
280	7	7	5	4.5	4.5	1.5	1.5	1.5
420	7	7	5	4.5	4.5	1.5	1.5	1.5
560	7	7	5	4.5	4	1.5	1.5	1.5
700	6	5	4	4		1	1	
840	6	4	3	3		1	1	
980	4	4	2.5	2		1	1	
1,120			2.5	1	1			0.5
1,260			1	0.5	0.5			

Lead 10

Orientation	Horizontal		Vertical					
	Acceleration (G)							
	0.1	0.3	0.5	0.7	1	0.1	0.3	0.5
Speed (mm/s)								
0	12	12	12	10	9	3	3	3
85	12	12	12	10	9	3	3	3
175	12	12	12	10	9	3	3	3
260	12	12	10	9	9	3	3	3
350	12	12	10	9	8	3	3	3
435	12	12	10	9	8	2.5	2.5	2.5
525	12	12	9	7	7	2.25	2.25	2.25
610		10	7	5	4	2.25	2	2
700		7	4	3	2		1.5	1
785		4	3	2	1.5		1	1

Lead 5

Orientation	Horizontal		Vertical					
	Acceleration (G)							
	0.1	0.3	0.5	0.7	1	0.1	0.3	0.5
Speed (mm/s)								
0	14	14	14	12	12	5.5	5.5	5.5
40	14	14	14	12	12	5.5	5.5	5.5
85	14	14	14	12	12	5.5	5.5	5.5
130	14	14	12	12	11	5.5	5.5	5.5
175	14	14	12	12	11	5.5	5.5	5.5
215	14	14	12	12	11	5.5	5.5	5.5
260	14	14	12	12	11	5.5	5.5	5
305	14	14	12	12	11	5	5	4.5
350	14	12	12	10	10	4	4	4
390	14	10	7	6	4	3.5	3.5	2.5

Lead 2.5

Orientation	Horizontal		Vertical					
	Acceleration (G)							
	0.1	0.3	0.5	0.7	1	0.1	0.3	0.5
Speed (mm/s)								
0	18	18	18	18	18	12	12	12
20	18	18	18	18	18	12	12	12
40	18	18	18	18	18	12	12	12
65	18	18	16	16	16	12	12	12
85	18	18	16	16	16	12	12	12
105	18	18	16	15	15	12	12	12
130	18	18	16	15	14	11	11	11
150	18	18	16	15	14	10	10	10
175	18	18	16	15	14	8	7	7
195	18	18	16	14	10	7	5	5

■ RCP6/RCP6S-SA6R

Lead 20

Orientation	Horizontal		Vertical					
	Acceleration (G)							
	0.1	0.3	0.5	0.7	1	0.1	0.3	0.5
Speed (mm/s)								
0	15	15	10	8	7	1	1	1
160	15	15	10	8	7	1	1	1
320	15	12	10	8	6	1	1	1
480	12	12	9	8	6	1	1	1
640	12	12	8	6	5	1	1	1
800	10	10	6.5	4.5	3	1	1	1
960		8	5	3.5	2		1	1
1,120		6	3	2	1.5		0.5	0.5
1,280		1	0.5	0.5				

Lead 12

Orientation	Horizontal		Vertical					
	Acceleration (G)							
	0.1	0.3	0.5	0.7	1	0.1	0.3	0.5
Speed (mm/s)								
0	28	26	18	16	14	2.5	2.5	2.5
80	28	26	18	16	14	2.5	2.5	2.5
200	28	26	18	16	14	2.5	2.5	2.5
320	28	26	18	14	12	2.5	2.5	2.5
440	28	26	18	12	10	2.5	2.5	2.5
560	28	20	12	8	7	2.5	2.5	2.5
680	20	15	9	5	3	2.5	2.5	2.5
800	15	9	5	2	1	2	1.5	1
900		5	3	1				

Lead 6

Orientation	Horizontal		Vertical					
	Acceleration (G)							
	0.1	0.3	0.5	0.7	1	0.1	0.3	0.5
Speed (mm/s)								
0	32	32	26	24	20	6	6	6
40	32	32	26	24	20	6	6	6
100	32	32	26	24	20	6	6	6
160	32	32	26	24	20	6	6	6
220	32	32	26	24	20	6	6	6
280	32	32	26	24	15	6	6	5.5
340	32	32	20	18	12	6	5	4.5
400	32	20	12	11	8	4.5	3.5	3.5
450	26	12	6	5	3	3	2	2

Lead 3

Orientation	Horizontal		Vertical					
	Acceleration (G)							
	0.1	0.3	0.5	0.7	1	0.1	0.3	0.5
Speed (mm/s)								
0	40	40	35	35	35	14	14	14
20	40	40	35	35	35	14	14	14
50	40	40	35	35	35	14	14	14
80	40	40	35	35	30	14	14	14
110	40	40	35	35	30	14	14	14
140	40	40	35	35	28	14	14	12
170	40	40	32	32	24	12	12	10
200	40	35	28	25	18	10	8	7
225	40	25	16	12	10	6	4	

■ RCP6/RCP6S-SA7R

Lead 24

Orientation	Horizontal		Vertical					
	Acceleration (G)							
	0.1	0.3	0.5	0.7	1	0.1	0.3	0.5
Speed (mm/s)								
0	37	37	22	16	14	3	3	3
200	37	37	22	16	14	3	3	3
420	37	30	18	16	14	3	3	3
640	37	18	15	10	9	3	3	3
860		12	10	3	2		3	2.5
1,080		2						0.5

Lead 16

Orientation	Horizontal		Vertical					
	Acceleration (G)							
	0.1	0.3	0.5	0.7	1	0.1	0.3	0.5
Speed (mm/s)								
0	46	46	35	28	27	8	8	8
140	46	46	35	28	27	8	8	8
280	46	46	35	25	21	8	8	8
420	46	30	20	15	10	6	5	4.5
560	35	20	13	10	6	5	4	3
700	20	13	6	3	2	3	2	1.5
840		4	1					

Lead 8

Orientation	Horizontal		Vertical					
	Acceleration (G)							
	0.1	0.3	0.5	0.7	1	0.1	0.3	0.5
Speed (mm/s)								
0	51	51	45	40	40	16	16	16
70	51	51	45	40	40	16	16	16
140	51	51	40	38	35	16	16	16
210	51	45	35	30	24	11	10	9.5
280	51	35	25	20	15	9	8	7
350	40	20	3	1		7	4	1
420	30	2				4		

Lead 4

Orientation	Horizontal		Vertical					
	Acceleration (G)							
	0.1	0.3	0.5	0.7	1	0.1	0.3	0.5
Speed (mm/s)								
0	55	55	45	40	40	25	25	25
35	55	55	45	40	40	25	25	25
70	55	55	45	40	40	25	25	25
105	55	55	45	40	35	22	20	19
140	55	45	35	30	25	16	14	12
175	55	30	16			11	7	5
210	40					4		

■ RCP6/RCP6S-SA8R

Lead 30

Orientation	Horizontal		Vertical					
	Acceleration (G)							
	0.1	0.3	0.5	0.7	1	0.1	0.3	0.5
Speed (mm/s)								
0	26	24	18	15	13	3	3	3
100	26	24	18	15	13	3	3	3
200	26	24	16	15	13	2	2	2
400	24	20	13	12	11	1.5	1.5	1
650	21	14	10	9	8	1	1	1
850		9	6	4	2		1	1
1,000		5	3	2	1			
1,200		1						

Lead 20

Orientation	Horizontal		Vertical					
	Acceleration (G)							
	0.1	0.3	0.5	0.7	1	0.1	0.3	0.5
Speed (mm/s)								
0	55	51	35	33	30	4	4	4
50	55	51	35	33	30	4	4	4
100	55	51	35	33	30	4	4	4
200	55	51	35	33	25	4	4	4
300	55	51	35	24	16	4	4	4
400	45	35	22	18	12	2	2	2
650	40	20	9	4	3	2	2	2
800		10	3	1	0.5	1	0.5	
900		7	1					
1,000		4						

Lead 10

Orientation	Horizontal		Vertical	
	Acceleration (G)</			

High-output Setting Disabled

■ RCP6/RCP6S-SA4R

Lead 16

Orientation	Horizontal					Vertical				
Speed (mm/s)	Acceleration (G)									
	0.1	0.3	0.5	0.7	1	0.1	0.3	0.5	0.7	1
0	4	3.5				1				
140	4	3.5				1				
280	4	3.5				1				
420	4	3				0.75				
560	3.5	2.5				0.75				
700	3	2				0.5				
840	2.5	1.5				0.5				

Lead 10

Orientation	Horizontal					Vertical				
Speed (mm/s)	Acceleration (G)									
	0.1	0.3	0.5	0.7	1	0.1	0.3	0.5	0.7	1
0	10	8				2.25				
85	10	8				2.25				
175	10	8				2.25				
260	9	6				2				
350	7	5				2				
435	6	4				1.5				
525	5	3				1				

Lead 5

Orientation	Horizontal					Vertical				
Speed (mm/s)	Acceleration (G)									
	0.1	0.3	0.5	0.7	1	0.1	0.3	0.5	0.7	1
0	12	10				4.5				
40	12	10				4.5				
85	12	10				4.5				
130	10	9				4				
175	10	8				4				
215	9	7				4				
260	8	6				2.5				

Lead 2.5

Orientation	Horizontal					Vertical				
Speed (mm/s)	Acceleration (G)									
	0.1	0.3	0.5	0.7	1	0.1	0.3	0.5	0.7	1
0	12	12				9				
20	12	12				9				
40	12	12				9				
65	12	11				8				
85	11	10				8				
105	10	9				8				
130	10	8				5				

■ RCP6/RCP6S-SA6R

Lead 20

Orientation	Horizontal					Vertical				
Speed (mm/s)	Acceleration (G)									
	0.1	0.3	0.5	0.7	1	0.1	0.3	0.5	0.7	1
0	8	5				0.75				
160	8	5				0.75				
320	8	5				0.75				
480	8	4				0.75				
640	6	3				0.75				
800	4	1.5				0.75				
960	2	0.5				0.5				

Lead 12

Orientation	Horizontal					Vertical				
Speed (mm/s)	Acceleration (G)									
	0.1	0.3	0.5	0.7	1	0.1	0.3	0.5	0.7	1
0	14	10				2				
80	14	10				2				
200	14	10				2				
320	14	10				2				
440	11	7				1.5				
560	7	2.5				1				
680	4	1				0.5				

Lead 6

Orientation	Horizontal					Vertical				
Speed (mm/s)	Acceleration (G)									
	0.1	0.3	0.5	0.7	1	0.1	0.3	0.5	0.7	1
0	20	14				5				
40	20	14				5				
100	20	14				5				
160	20	14				5				
220	16	14				4				
280	13	7				2.5				
340	10	1				1				

Lead 3

Orientation	Horizontal					Vertical				
Speed (mm/s)	Acceleration (G)									
	0.1	0.3	0.5	0.7	1	0.1	0.3	0.5	0.7	1
0	25	22				10				
20	25	22				10				
50	25	22				10				
80	25	22				10				
110	20	14				8				
140	15	11				5				
170	11	9				2				

■ RCP6/RCP6S-SA7R

Lead 24

Orientation	Horizontal					Vertical				
Speed (mm/s)	Acceleration (G)									
	0.1	0.3	0.5	0.7	1	0.1	0.3	0.5	0.7	1
0	18	10				2				
200	18	10				2				
420	18	10				2				
640	10	2				1				
800	5	0.5				0.5				

Lead 16

Orientation	Horizontal					Vertical				
Speed (mm/s)	Acceleration (G)									
	0.1	0.3	0.5	0.7	1	0.1	0.3	0.5	0.7	1
0	35	20				5				
140	35	20				5				
280	25	12				3				
420	15	6				1.5				
560	7	0.5				0.5				

Lead 8

Orientation	Horizontal					Vertical				
Speed (mm/s)	Acceleration (G)									
	0.1	0.3	0.5	0.7	1	0.1	0.3	0.5	0.7	1
0	40	25				10				
70	40	25				10				
140	40	25				7				
210	25	14				4				
280	10	1				1.5				

Lead 4

Orientation	Horizontal					Vertical				
Speed (mm/s)	Acceleration (G)									
	0.1	0.3	0.5	0.7	1	0.1	0.3	0.5	0.7	1
0	40	30				15				
35	40	30				15				
70	40	30				15				
105	40	30				8				
140	15	6				2				

Tables of Payload by Speed/Acceleration

RCP6 Series

Slider Type Motor Coupling Specification

* RCP6CR is the same.

High-output Setting Enabled

■ RCP6/RCP6S-WSA10C

Lead 16

Orientation	Horizontal				
	Acceleration (G)				
Speed (mm/s)	0.1	0.3	0.5	0.7	1
0	4	4	3	3	2.5
140	4	4	3	3	2.5
280	4	4	3	3	2.5
420	4	4	3	3	2.5
560	4	4	3	1.5	1.5
700	4	4	3	0.5	0.5
840		1	0.5		

Lead 10

Orientation	Horizontal				
	Acceleration (G)				
Speed (mm/s)	0.1	0.3	0.5	0.7	1
0	15	15	13	13	12
85	15	15	13	13	12
175	15	15	13	12	10
260	15	15	13	10	8
350	15	15	13	8	5
435	15	15	10	7	4
525	15	10	5	3	2
610	15	5	2	1	

Lead 5

Orientation	Horizontal					Vertical		
	Acceleration (G)							
Speed (mm/s)	0.1	0.3	0.5	0.7	1	0.1	0.3	0.5
0	28	25	22	20	20	3	3	3
40	28	25	22	20	20	3	3	3
85	28	25	22	20	20	3	3	3
130	28	25	22	20	20	3	3	3
175	28	25	22	20	20	3	3	3
215	28	25	22	20	18	3	3	3
260	28	25	22	20	14	3	3	3
305	28	22	18	14	10	2	1.5	1.5
350	28	18	11	7	6	1		
390	28	12	7	4	2			

Lead 2.5

Orientation	Horizontal					Vertical		
	Acceleration (G)							
Speed (mm/s)	0.1	0.3	0.5	0.7	1	0.1	0.3	0.5
0	40	40	40	35	30	10	10	10
20	40	40	40	35	30	10	10	10
40	40	40	40	35	30	10	10	10
65	40	40	40	35	30	10	10	10
85	40	40	40	35	30	10	10	10
105	40	40	35	35	30	10	10	10
130	40	40	35	30	30	10	10	9
150	40	35	35	30	30	7	7	7
175	40	35	35	30	25	3	3	3
195	40	35	30	26	18			

■ RCP6/RCP6S-WSA12C

Lead 20

Orientation	Horizontal				
	Acceleration (G)				
Speed (mm/s)	0.1	0.3	0.5	0.7	1
0	12	12	12	11	11
160	12	12	12	11	11
320	12	12	12	11	9
480	12	12	12	11	9
640		12	10	9	8
800		10	9		

Lead 12

Orientation	Horizontal				
	Acceleration (G)				
Speed (mm/s)	0.1	0.3	0.5	0.7	1
0	25	25	18	16	12
100	25	25	18	16	12
200	25	25	18	16	10
285	25	25	18	12	8
400	20	20	14	10	6
500	15	15	8	6	4
600	10	10	6	3	2

Lead 6

Orientation	Horizontal					Vertical		
	Acceleration (G)							
Speed (mm/s)	0.1	0.3	0.5	0.7	1	0.1	0.3	0.5
0	40	40	35	30	25	9	9	9
50	40	40	35	30	25	9	9	9
100	40	40	35	30	25	9	9	9
140	40	40	35	25	25	9	9	9
200	40	40	30	25	20	9	9	9
250	40	40	27.5	22.5	18	9	8	8
290	40	35	25	20	14	5	5	4
350	40	28	14	12	10	2	2	1
400	30	18	10	6	5	0.5		
450	25	8	3					

Lead 3

Orientation	Horizontal					Vertical		
	Acceleration (G)							
Speed (mm/s)	0.1	0.3	0.5	0.7	1	0.1	0.3	0.5
0	60	56	50	45	40	18	18	18
25	60	56	50	45	40	18	18	18
50	60	56	50	45	40	18	18	18
65	60	56	46	41	40	18	18	18
100	60	56	46	41	40	18	18	18
125	60	56	46	40	30	18	18	10
150	60	50	40	30	25	14	14	6
180	60	40	35	25	20	11	11	5
200	60	35	30	20	14	7	6	4.5
225	40	16	16	10	6	5	3	2

■ RCP6/RCP6S-WSA14C

Lead 24

Orientation	Horizontal				
	Acceleration (G)				
Speed (mm/s)	0.1	0.3	0.5	0.7	1
0	25	25	23	20	17
140	25	25	23	20	17
420	25	25	23	20	15
560	20	19	14	12	9
700	20	10	6	6	6

Lead 16

Orientation	Horizontal				
	Acceleration (G)				
Speed (mm/s)	0.1	0.3	0.5	0.7	1
0	50	42	40	32	30
140	50	42	40	32	30
280	50	42	35	23	17
420	47	25	18	14	10
560	12	10	5	3	2

Lead 8

Orientation	Horizontal					Vertical		
	Acceleration (G)							
Speed (mm/s)	0.1	0.3	0.5	0.7	1	0.1	0.3	0.5
0	65	65	55	50	45	14	14	14
70	65	65	55	50	45	14	14	14
140	65	65	55	46	45	12	12	12
210	65	65	45	36	22	10	10	9
280	65	39	27	18	12	8	5	4
350	61	19	10			2		
420	20	6						

Lead 4

Orientation	Horizontal					Vertical		
	Acceleration (G)							
Speed (mm/s)	0.1	0.3	0.5	0.7	1	0.1	0.3	0.5
0	80	80	70	65	60	26	26	26
35	80	80	70	65	60	26	26	26
70	80	80	70	65	60	26	26	26
105	80	80	60	50	40	22	20	18
140	80	50	30	20	15	16	12	10
175	50	15				6	1	
210	20							

■ RCP6/RCP6S-WSA16C

* WSA16C does not have high output enable/disable settings.

Lead 20

Orientation	Horizontal				
	Acceleration (G)				
Speed (mm/s)	0.1	0.3	0.5	0.7	1
0	50	35	28	24	20
120	50	35	28	24	20
240	50	35	28	24	16
365	50	35	28	20	12
480	40	14	4	2	
550	40	4			
600	30				
665	18				
720	18				

Lead 10

Orientation	Horizontal					Vertical		
	Acceleration (G)							
Speed (mm/s)	0.1	0.3	0.5	0.7	1	0.1	0.3	0.5
0	70	70	60	60	60	15	15	15
80	70	70	60	60	60	15	15	15
160	70	70	55	50	45	15	15	15
210	70	70	55	50	40	5	4	4
240	70	55	50	35	30	2		
270	70	40	30	24	20			
330	70	14	2					
365	70							
405	40							
450	22							

Lead 5

Orientation	Horizontal					Vertical		
	Acceleration (G)							
Speed (mm/s)	0.1	0.3	0.5	0.7	1	0.1	0.3	0.5
0	100	90	90	90	90	50	50	50
60	100	90	90	90	90	50	50	50
95	100	90	90	80	80	30	30	30
120	100	90	70	70	70	19	19	19
145	100	70	45	35	30	11	7	7
160	90	35	18	16	12	7	2	
170	90	2				4		
195	50							

Foreword
Slider Type
Wide Slider Type
Rod Type
Radial Cylinder
Wide Radial Cylinder
Table Type
Cleanroom Slider
Cleanroom Wide Slider
Dust/Splash-Proof Rod
Dust/Splash-Proof Radial Cylinder
Dust/Splash-Proof Wide Radial Cylinder
Options
Reference Data
Controller

* RCP6CR is the same.

High-output Setting Disabled

■ RCP6/RCP6S-WSA10C

Lead 16

Orientation	Horizontal				
Speed (mm/s)	Acceleration (G)				
	0.1	0.3	0.5	0.7	1
0	4	3			
140	4	3			
280	4	3			
420	4	3			
560	3.5	1			

Lead 10

Orientation	Horizontal				
Speed (mm/s)	Acceleration (G)				
	0.1	0.3	0.5	0.7	1
0	12	9.5			
85	12	9.5			
175	12	9			
260	12	9			
350	10.5	6.5			
435	6	3.5			
525	3	1.5			

Lead 5

Orientation	Horizontal					Vertical		
	Acceleration (G)							
Speed (mm/s)	0.1	0.3	0.5	0.7	1	0.1	0.3	0.5
	0	25	20				3	
40	25	20				3		
85	25	20				3		
130	25	20				3		
175	25	19				3		
215	19	13				3		
260	10.5	7.5				2		

Lead 2.5

Orientation	Horizontal					Vertical		
	Acceleration (G)							
Speed (mm/s)	0.1	0.3	0.5	0.7	1	0.1	0.3	0.5
	0	36	27				10	
20	36	27				10		
40	36	27				10		
65	36	27				10		
85	36	27				9		
105	36	27				7		
130	33	20				4.5		

■ RCP6/RCP6S-WSA12C

Lead 20

Orientation	Horizontal				
Speed (mm/s)	Acceleration (G)				
	0.1	0.3	0.5	0.7	1
0	8	4			
160	8	4			
320	8	4			
480	8	4			
640	5	3			

Lead 12

Orientation	Horizontal				
Speed (mm/s)	Acceleration (G)				
	0.1	0.3	0.5	0.7	1
0	18	15.5			
100	18	15.5			
200	18	14			
285	18	11			
400	12	7.5			
500	6	4			

Lead 6

Orientation	Horizontal					Vertical		
	Acceleration (G)							
Speed (mm/s)	0.1	0.3	0.5	0.7	1	0.1	0.3	0.5
	0	30	30				8	
50	30	30				8		
100	30	30				8		
140	30	30				8		
200	30	19				5.5		
250	19	16.5				3		
290	14	9				2		

Lead 3

Orientation	Horizontal					Vertical		
	Acceleration (G)							
Speed (mm/s)	0.1	0.3	0.5	0.7	1	0.1	0.3	0.5
	0	42	33				15	
25	42	33				15		
50	42	33				15		
65	42	33				13		
100	42	33				12		
125	42	30				8		
150	30	24				4.5		

■ RCP6/RCP6S-WSA14C

Lead 24

Orientation	Horizontal				
Speed (mm/s)	Acceleration (G)				
	0.1	0.3	0.5	0.7	1
0	15.5	12			
140	15.5	12			
420	13	8			
560	7.5	3			

Lead 16

Orientation	Horizontal				
Speed (mm/s)	Acceleration (G)				
	0.1	0.3	0.5	0.7	1
0	33	24.5			
140	33	24.5			
280	22.5	12.5			
420	9.5	3.5			

Lead 8

Orientation	Horizontal					Vertical		
	Acceleration (G)							
Speed (mm/s)	0.1	0.3	0.5	0.7	1	0.1	0.3	0.5
	0	45	33				11	
70	45	33				11		
140	45	27.5				10.5		
210	13.5	9				3		

Lead 4

Orientation	Horizontal					Vertical		
	Acceleration (G)							
Speed (mm/s)	0.1	0.3	0.5	0.7	1	0.1	0.3	0.5
	0	54	48				18	
35	54	48				18		
70	54	48				18		
105	36	24				6		

Tables of Payload by Speed/Acceleration

RCP6 Series

Slider Type Side-Mounted Motor Specification

High-output Setting Enabled

■ RCP6/RCP6S-WSA10R

Lead 16

Orientation	Horizontal				
	Acceleration (G)				
Speed (mm/s)	0.1	0.3	0.5	0.7	1
0	4	4	3	3	2.5
140	4	4	3	3	2.5
280	4	4	3	3	2.5
420	4	4	3	3	2.5
560	4	4	3	1.5	1.5
700	4	4	3	0.5	0.5
840		1	0.5		

Lead 10

Orientation	Horizontal				
	Acceleration (G)				
Speed (mm/s)	0.1	0.3	0.5	0.7	1
0	15	15	13	13	12
85	15	15	13	13	12
175	15	15	13	12	10
260	15	15	13	10	8
350	15	15	13	8	5
435	15	15	10	7	4
525	14	10	5	3	2
610		5	2	1	

Lead 5

Orientation	Horizontal					Vertical		
	Acceleration (G)							
Speed (mm/s)	0.1	0.3	0.5	0.7	1	0.1	0.3	0.5
0	28	25	22	20	20	3	3	3
40	28	25	22	20	20	3	3	3
85	28	25	22	20	20	3	3	3
130	28	25	22	20	20	3	3	3
175	28	25	22	20	20	3	3	3
215	28	25	22	20	16	3	3	3
260	28	25	20	16	12	2	2	2.5
305	28	20	12	10	8	1	0.5	0.5
350	28	14	6	4	3			
390	28	6	1					

Lead 2.5

Orientation	Horizontal					Vertical		
	Acceleration (G)							
Speed (mm/s)	0.1	0.3	0.5	0.7	1	0.1	0.3	0.5
0	40	40	40	35	30	10	10	10
20	40	40	40	35	30	10	10	10
40	40	40	36	35	30	10	10	10
65	40	40	36	35	30	10	10	10
85	40	40	36	35	30	10	10	10
105	40	40	35	35	30	10	10	10
130	40	40	35	30	30	7	7	7
150	40	35	35	30	30	4	4	4
175	40	34	32	24	20	1	1	1
195	40	20	14	12	11			

■ RCP6/RCP6S-WSA12R

Lead 20

Orientation	Horizontal				
	Acceleration (G)				
Speed (mm/s)	0.1	0.3	0.5	0.7	1
0	12	8	6	4	3
160	12	8	6	4	3
320	12	8	6	4	3
480	12	8	6	4	2
640		8	6	4	1
800		7	4		

Lead 12

Orientation	Horizontal				
	Acceleration (G)				
Speed (mm/s)	0.1	0.3	0.5	0.7	1
0	25	25	18	16	10
100	25	25	18	16	10
200	25	25	18	16	10
285	25	25	18	12	8
400	20	20	14	10	6
500	15	15	8	6	4
600	10	6	6	3	2

Lead 6

Orientation	Horizontal					Vertical		
	Acceleration (G)							
Speed (mm/s)	0.1	0.3	0.5	0.7	1	0.1	0.3	0.5
0	40	40	35	30	25	9	9	9
50	40	40	35	30	25	9	9	9
100	40	40	35	30	25	9	9	9
140	40	40	35	25	25	9	9	9
200	40	40	30	25	20	9	9	8
250	40	40	27.5	22.5	18	9	8	4
290	40	35	25	20	14	5	5	4
350	40	28	14	12	10	2	2	1
400	30	18	10	6	5	1		
450	25	8	3					

Lead 3

Orientation	Horizontal					Vertical		
	Acceleration (G)							
Speed (mm/s)	0.1	0.3	0.5	0.7	1	0.1	0.3	0.5
0	60	56	50	45	40	16	16	16
25	60	56	50	45	40	16	16	16
50	60	56	50	45	40	16	16	16
65	60	56	46	41	40	16	16	16
100	60	56	46	41	40	16	16	16
125	60	56	46	40	30	16	14	10
150	60	50	40	30	25	12	10	6
180	60	40	35	25	20	8	6	5
200	60	35	30	20	14	5	5	4
225	40	16	16	10	6	2		

■ RCP6/RCP6S-WSA14R

Lead 24

Orientation	Horizontal				
	Acceleration (G)				
Speed (mm/s)	0.1	0.3	0.5	0.7	1
0	25	23	19	14	11
140	25	23	19	14	11
420	25	23	19	13	8
560	20	19	14	10	5
700	20	8	6	6	3

Lead 16

Orientation	Horizontal				
	Acceleration (G)				
Speed (mm/s)	0.1	0.3	0.5	0.7	1
0	50	42	40	32	30
140	50	42	40	32	30
280	50	42	35	23	17
420	47	25	18	14	10
560	12	10	5	3	2

Lead 8

Orientation	Horizontal					Vertical		
	Acceleration (G)							
Speed (mm/s)	0.1	0.3	0.5	0.7	1	0.1	0.3	0.5
0	65	65	55	50	45	14	14	14
70	65	65	55	50	45	14	14	14
140	65	65	51	46	45	12	12	12
210	65	65	45	31	22	8	6	6
280	65	31	21	14	6	6	4	2
350	35	8				1		
420	7							

Lead 4

Orientation	Horizontal					Vertical		
	Acceleration (G)							
Speed (mm/s)	0.1	0.3	0.5	0.7	1	0.1	0.3	0.5
0	80	80	70	65	60	26	26	26
35	80	80	70	65	60	26	26	26
70	80	80	70	65	60	26	26	26
105	80	80	60	50	40	22	20	18
140	80	50	10	6	6	13	8	3
175	40	5				4		

■ RCP6/RCP6S-WSA16R

* WSA16R does not have high output enable/disable settings.

Lead 20

Orientation	Horizontal				
	Acceleration (G)				
Speed (mm/s)	0.1	0.3	0.5	0.7	1
0	30	30	28	24	20
120	30	30	28	24	20
240	30	30	28	20	16
365	30	28	18	12	6
480	30	6			
550	14				
600	2				

Lead 10

Orientation	Horizontal					Vertical		
	Acceleration (G)							
Speed (mm/s)	0.1	0.3	0.5	0.7	1	0.1	0.3	0.5
0	70	70	60	60	60	15	15	15
80	70	70	60	60	60	15	15	15
160	70	70	55	45	45	10	10	10
210	70	65	45	30	28	2	2	1
240	70	30	22	14	10			
270	70	12	6	4				
330	35							
365	12							

Lead 5

Orientation	Horizontal					Vertical		
	Acceleration (G)							
Speed (mm/s)	0.1	0.3	0.5	0.7	1	0.1	0.3	0.5
0	100	90	90	90	90	45	45	45
60	100	90	90	90	90	45	45	45
95	100	90	90	80	80	27	27	27
120	100	90	65	50	45	7	7	7
145	80					1		
160	35							
170	8							

High-output Setting Disabled

■ RCP6/RCP6S-WSA10R

Lead 16

Orientation	Horizontal				
	Acceleration (G)				
Speed (mm/s)	0.1	0.3	0.5	0.7	1
0	4	3			
140	4	3			
280	4	3			
420	4	3			
560	3.5	1			

Lead 10

Orientation	Horizontal				
	Acceleration (G)				
Speed (mm/s)	0.1	0.3	0.5	0.7	1
0	12	9.5			
85	12	9.5			
175	12	9			
260	12	9			
350	10.5	6.5			
435	6	3.5			
525	3	1.5			

Lead 5

Orientation	Horizontal					Vertical		
	Acceleration (G)							
Speed (mm/s)	0.1	0.3	0.5	0.7	1	0.1	0.3	0.5
0	25	20				3		
40	25	20				3		
85	25	20				3		
130	25	20				3		
175	25	19				3		
215	19	13				3		
260	10.5	7.5				2		

Lead 2.5

Orientation	Horizontal					Vertical		
	Acceleration (G)							
Speed (mm/s)	0.1	0.3	0.5	0.7	1	0.1	0.3	0.5
0	36	27				10		
20	36	27				10		
40	36	27				10		
65	36	27				10		
85	36	27				9		
105	36	27				7		
130	33	20				4.5		

■ RCP6/RCP6S-WSA12R

Lead 20

Orientation	Horizontal				
	Acceleration (G)				
Speed (mm/s)	0.1	0.3	0.5	0.7	1
0	8	4			
160	8	4			
320	8	4			
480	8	4			
640	5	3			

Lead 12

Orientation	Horizontal				
	Acceleration (G)				
Speed (mm/s)	0.1	0.3	0.5	0.7	1
0	18	15.5			
100	18	15.5			
200	18	14			
285	18	11			
400	12	7.5			
500	6	4			

Lead 6

Orientation	Horizontal					Vertical		
	Acceleration (G)							
Speed (mm/s)	0.1	0.3	0.5	0.7	1	0.1	0.3	0.5
0	30	30				8		
50	30	30				8		
100	30	30				8		
140	30	30				8		
200	30	19				5.5		
250	19	16.5				3		
290	14	9				2		

Lead 3

Orientation	Horizontal					Vertical		
	Acceleration (G)							
Speed (mm/s)	0.1	0.3	0.5	0.7	1	0.1	0.3	0.5
0	42	33				15		
25	42	33				15		
50	42	33				15		
65	42	33				13		
100	42	33				12		
125	42	30				8		
150	30	24				4.5		

■ RCP6/RCP6S-WSA14R

Lead 24

Orientation	Horizontal				
	Acceleration (G)				
Speed (mm/s)	0.1	0.3	0.5	0.7	1
0	15.5	12			
140	15.5	12			
420	13	8			
560	7.5	3			

Lead 16

Orientation	Horizontal				
	Acceleration (G)				
Speed (mm/s)	0.1	0.3	0.5	0.7	1
0	33	24.5			
140	33	24.5			
280	22.5	12.5			
420	9.5	3.5			

Lead 8

Orientation	Horizontal					Vertical		
	Acceleration (G)							
Speed (mm/s)	0.1	0.3	0.5	0.7	1	0.1	0.3	0.5
0	45	33				11		
70	45	33				11		
140	45	27.5				10.5		
210	13.5	9				3		

Lead 4

Orientation	Horizontal					Vertical		
	Acceleration (G)							
Speed (mm/s)	0.1	0.3	0.5	0.7	1	0.1	0.3	0.5
0	54	48				18		
35	54	48				18		
70	54	48				18		
105	36	24				6		

Tables of Payload by Speed/Acceleration

RCP6 Series

Rod Type Motor Coupling Specification

* Dust-proof/splash-proof specifications have different specs.

High-output Setting Enabled

■ RCP6/RCP6S-RR4C

Lead 16

Orientation	Horizontal					Vertical				
	Acceleration (G)									
Speed (mm/s)	0.1	0.3	0.5	0.7	1	0.1	0.3	0.5	0.7	1
0	7	7	6	5	3.5	1.5	1.5	1.5	1.5	1.5
140	7	7	6	5	3.5	1.5	1.5	1.5	1.5	1.5
280	7	7	6	5	3.5	1.5	1.5	1.5	1.5	1.5
420	7	7	6	5	3.5	1.5	1.5	1.5	1.5	1.5
560	6.5	6	5	3.5	1	1.5	1.5	1.5	1.5	1.5
700	5.5	5	4	2.5	1	1	1	1	1	1
840	4.5	3.5	3	2	1	1	1	1	1	1
980		2.5	2	1.5	1	0.75	0.75	0.75	0.75	0.75
1,120		1	1	0.75	0.5	0.5	0.5	0.5	0.5	0.5

Lead 10

Orientation	Horizontal					Vertical				
	Acceleration (G)									
Speed (mm/s)	0.1	0.3	0.5	0.7	1	0.1	0.3	0.5	0.7	1
0	18	17	15	14	13	3	3	3	3	3
85	18	17	15	14	13	3	3	3	3	3
175	18	17	15	14	12	3	3	3	3	3
260	18	17	13	13	12	3	3	3	3	3
350	18	17	13	13	10	2.5	2.5	2.5	2.5	2.5
435	18	17	13	11	9	2.5	2.5	2.5	2.5	2.5
525	18	15	10	8	7	2.5	2.5	2.5	2.5	2.5
610		9	7	5	4	2	2	2	2	2
700		6	5	3	2	1.5	1.5	1.5	1.5	1.5

Lead 5

Orientation	Horizontal					Vertical				
	Acceleration (G)									
Speed (mm/s)	0.1	0.3	0.5	0.7	1	0.1	0.3	0.5	0.7	1
0	28	25	22	20	20	6	6	6	6	6
40	28	25	22	20	20	6	6	6	6	6
85	28	25	22	20	20	6	6	6	6	6
130	28	25	22	20	20	6	6	6	6	6
175	28	25	22	20	20	5	5	5	5	5
215	28	25	22	20	20	5	5	5	5	5
260	28	25	22	20	16	5	5	5	5	5
305	28	22	20	16	14	5	5	5	5	5
350	28	20	14	12	11	4.5	3	3	3	3

Lead 2.5

Orientation	Horizontal					Vertical				
	Acceleration (G)									
Speed (mm/s)	0.1	0.3	0.5	0.7	1	0.1	0.3	0.5	0.7	1
0	40	40	40	35	30	10	10	10	10	10
20	40	40	40	35	30	10	10	10	10	10
40	40	40	40	35	30	10	10	10	10	10
65	40	40	40	35	30	10	10	10	10	10
85	40	40	40	35	30	10	10	10	10	10
105	40	40	35	35	30	10	10	10	10	10
130	40	40	35	30	30	10	10	10	10	9
150	40	35	35	30	30	10	9	8	7	7
175	40	35	35	30	25	8	7	7	7	7

■ RCP6/RCP6S-RR6C

Lead 20

Orientation	Horizontal					Vertical				
	Acceleration (G)									
Speed (mm/s)	0.1	0.3	0.5	0.7	1	0.1	0.3	0.5	0.7	1
0	6	6	6	5	5	1.5	1.5	1.5	1.5	1.5
160	6	6	6	5	5	1.5	1.5	1.5	1.5	1.5
320	6	6	6	5	3	1.5	1.5	1.5	1.5	1.5
480	6	6	6	5	3	1.5	1.5	1.5	1.5	1.5
640	6	4	3	2		1.5	1.5	1.5	1.5	1.5
800	4	3				1	1	1	1	1

Lead 12

Orientation	Horizontal					Vertical				
	Acceleration (G)									
Speed (mm/s)	0.1	0.3	0.5	0.7	1	0.1	0.3	0.5	0.7	1
0	25	25	18	16	12	4	4	4	4	4
100	25	25	18	16	12	4	4	4	4	4
200	25	25	18	16	10	4	4	4	4	4
300	25	25	18	12	8	4	4	4	4	4
400	20	20	14	10	6	4	4	4	4	4
500	15	15	8	6	4	4	3.5	3	3	3
600	10	10	6	3	2	4	3	2	2	2
700		6	2			2	1	1	1	1

Lead 6

Orientation	Horizontal					Vertical				
	Acceleration (G)									
Speed (mm/s)	0.1	0.3	0.5	0.7	1	0.1	0.3	0.5	0.7	1
0	40	40	35	30	25	10	10	10	10	10
50	40	40	35	30	25	10	10	10	10	10
100	40	40	35	30	25	10	10	10	10	10
150	40	40	35	25	25	10	10	10	10	10
200	40	40	30	25	20	10	10	10	10	10
250	40	40	27.5	22.5	18	10	9	8	8	8
300	40	35	25	20	14	6	6	6	6	6
350	40	30	14	12	10	5	5	5	5	5
400	30	18	10	6	5	4	3	3	3	3
450	25	8	3			2	2	2	2	2

Lead 3

Orientation	Horizontal					Vertical				
	Acceleration (G)									
Speed (mm/s)	0.1	0.3	0.5	0.7	1	0.1	0.3	0.5	0.7	1
0	60	60	50	45	40	20	20	20	20	20
25	60	60	50	45	40	20	20	20	20	20
50	60	60	50	45	40	20	20	20	20	20
75	60	60	50	45	40	20	20	20	20	20
100	60	60	50	45	40	20	20	20	20	20
125	60	60	50	40	30	18	14	10	10	10
150	60	50	40	30	25	14	10	6	6	6
175	60	40	35	25	20	12	6	5	5	5
200	60	35	30	20	14	8	5	4.5	4.5	4.5
225	40	16	16	10	6	5	5	4	4	4

■ RCP6/RCP6S-RR7C

Lead 24

Orientation	Horizontal					Vertical				
	Acceleration (G)									
Speed (mm/s)	0.1	0.3	0.5	0.7	1	0.1	0.3	0.5	0.7	1
0	20	20	18	15	12	3	3	3	3	3
200	20	20	18	15	12	3	3	3	3	3
420	20	20	18	15	10	3	3	3	3	3
640	15	14	9	7	4	3	3	2	2	2
860		5	1	1		3	3	2	2	2

Lead 16

Orientation	Horizontal					Vertical				
	Acceleration (G)									
Speed (mm/s)	0.1	0.3	0.5	0.7	1	0.1	0.3	0.5	0.7	1
0	50	50	40	35	30	8	8	8	8	8
140	50	50	40	35	30	8	8	8	8	8
280	50	50	35	25	20	8	7	7	7	7
420	50	25	18	14	10	6	4.5	4	4	4
560	12	10	5	3	2	4	2	1	1	1
700	3	2								

Lead 8

Orientation	Horizontal					Vertical				
	Acceleration (G)									
Speed (mm/s)	0.1	0.3	0.5	0.7	1	0.1	0.3	0.5	0.7	1
0	60	60	50	45	40	18	18	18	18	18
70	60	60	50	45	40	18	18	18	18	18
140	60	60	50	45	40	16	16	12	12	12
210	60	60	40	31	26	10	10	9	9	9
280	60	34	22	15	11	8	7	6	6	6
350	60	14	5	1		3	2.5	1.5	1.5	1.5
420	15	1				1				

Lead 4

Orientation	Horizontal					Vertical				
	Acceleration (G)									
Speed (mm/s)	0.1	0.3	0.5	0.7	1	0.1	0.3	0.5	0.7	1
0	80	80	70	65	60	28	28	28	28	28
35	80	80	70	65	60	28	28	28	28	28
70	80	80	70	65	60	28	28	28	28	28
105	80	80	60	50	40	22	20	18	18	18
140	80	50	30	20	15	16	12	10	10	10
175	50	15				8.5	4			
210	20					1.5				

■ RCP6/RCP6S-RR8C

Lead 20

Orientation	Horizontal		Orientation	Vertical	
	Acceleration (G)			Acceleration (G)	
Speed (mm/s)	0.2		Speed (mm/s)	0.2	
0	30		0	5	
240	30		5	5	
270	30		100	5	
300	30		150	5	
360	24		180	5	
420	16		200	5	
450	12		240	5	
480	10		300	5	
510	8		360	5	
540	6		400	3	
600	5		420	2.5	
			450	2	

Lead 10

Orientation	Horizontal		Orientation	Vertical	
	Acceleration (G)			Acceleration (G)	
Speed (mm/s)					

High-output Setting Disabled

■ RCP6/RCP6S-RR4C

Lead 16

Orientation	Horizontal					Vertical				
Speed (mm/s)	Acceleration (G)									
	0.1	0.3	0.5	0.7	1	0.1	0.3	0.5		
0	5	3				1				
140	5	3				1				
280	5	3				1				
420	4	2.5				0.5				
560	3	1.5				0.5				

Lead 10

Orientation	Horizontal					Vertical				
Speed (mm/s)	Acceleration (G)									
	0.1	0.3	0.5	0.7	1	0.1	0.3	0.5		
0	10	8				2				
85	10	8				2				
175	10	8				2				
260	9	7				2				
350	7	5				1.5				
435	6	3				1				
525	1					0.5				

Lead 5

Orientation	Horizontal					Vertical				
Speed (mm/s)	Acceleration (G)									
	0.1	0.3	0.5	0.7	1	0.1	0.3	0.5		
0	22	20				5				
40	22	20				5				
85	22	20				5				
130	22	18				5				
175	20	14				4				
215	15	10				3				
260	12	6				2				

Lead 2.5

Orientation	Horizontal					Vertical				
Speed (mm/s)	Acceleration (G)									
	0.1	0.3	0.5	0.7	1	0.1	0.3	0.5		
0	35	30				10				
20	35	30				10				
40	35	30				10				
65	35	25				10				
85	30	20				7				
105	25	15				5				
130	20	10				4				

■ RCP6/RCP6S-RR6C

Lead 20

Orientation	Horizontal					Vertical				
Speed (mm/s)	Acceleration (G)									
	0.1	0.3	0.5	0.7	1	0.1	0.3	0.5		
0	6	5				1				
160	6	5				1				
320	6	5				1				
480	4	3				1				
640	3	1				0.5				

Lead 12

Orientation	Horizontal					Vertical				
Speed (mm/s)	Acceleration (G)									
	0.1	0.3	0.5	0.7	1	0.1	0.3	0.5		
0	25	10				4				
100	25	10				4				
200	25	10				4				
300	20	8				3				
400	10	5				2				
500	5	2				1				

Lead 6

Orientation	Horizontal					Vertical				
Speed (mm/s)	Acceleration (G)									
	0.1	0.3	0.5	0.7	1	0.1	0.3	0.5		
0	40	20				10				
50	40	20				10				
100	40	20				10				
150	40	20				8				
200	35	18				5				
250	10	6				3				

Lead 3

Orientation	Horizontal					Vertical				
Speed (mm/s)	Acceleration (G)									
	0.1	0.3	0.5	0.7	1	0.1	0.3	0.5		
0	40	25				20				
25	40	25				20				
50	40	25				20				
75	40	25				12				
100	40	25				9				
125	40	25				5				

■ RCP6/RCP6S-RR7C

Lead 24

Orientation	Horizontal					Vertical				
Speed (mm/s)	Acceleration (G)									
	0.1	0.3	0.5	0.7	1	0.1	0.3	0.5		
0	18	9.5				3				
200	18	9.5				3				
420	10	5				1.5				
600	1									

Lead 16

Orientation	Horizontal					Vertical				
Speed (mm/s)	Acceleration (G)									
	0.1	0.3	0.5	0.7	1	0.1	0.3	0.5		
0	40	25				5				
140	40	25				5				
280	18	12				2				
420	1.5	1								

Lead 8

Orientation	Horizontal					Vertical				
Speed (mm/s)	Acceleration (G)									
	0.1	0.3	0.5	0.7	1	0.1	0.3	0.5		
0	50	30				17.5				
70	50	30				17.5				
140	50	30				7				
210	14	7				2				

Lead 4

Orientation	Horizontal					Vertical				
Speed (mm/s)	Acceleration (G)									
	0.1	0.3	0.5	0.7	1	0.1	0.3	0.5		
0	55	50				26				
35	55	50				26				
70	55	50				13				
105	30	15				2				

Tables of Payload by Speed/Acceleration

RCP6 Series

Rod Type Side-Mounted Motor Specification

* Dust-proof/splash-proof specifications have different specs.

High-output Setting Enabled

■ RCP6/RCP6S-RR4R

Lead 16

Orientation	Horizontal				Vertical			
	Acceleration (G)							
Speed (mm/s)	0.1	0.3	0.5	0.7	1	0.1	0.3	0.5
0	5	5	4.5	3	2.5	1	1	1
140	5	5	4.5	3	2.5	1	1	1
280	5	5	4.5	3	2	1	1	1
420	5	5	4.5	3	2	1	1	1
560	5	4.5	2.5	2	1	1	1	1
700	4.5	3.5	2	1.5		1	1	
840	3	2.5	1	0.5		0.5	0.5	

Lead 10

Orientation	Horizontal					Vertical				
	Acceleration (G)									
Speed (mm/s)	0.1	0.3	0.5	0.7	1	0.1	0.3	0.5		
0	13	13	12	10	8	2.5	2.5	2.5		
85	13	13	12	10	8	2.5	2.5	2.5		
175	13	13	12	10	8	2.5	2.5	2.5		
260	13	13	12	10	6	2.5	2.5	2.5		
350	13	12	12	8	5	2.5	2.5	2.5		
435	13	10	10	6	4	2.5	2.5	2.5		
525	13	8	6	3	2	2.5	2.5	2		
610		5	2					2	1.5	

Lead 5

Orientation	Horizontal					Vertical				
	Acceleration (G)									
Speed (mm/s)	0.1	0.3	0.5	0.7	1	0.1	0.3	0.5		
0	28	25	22	20	18	5	5	5		
40	28	25	22	20	18	5	5	5		
85	28	25	22	20	18	5	5	5		
130	28	25	22	20	18	5	5	5		
175	28	25	22	20	18	5	5	5		
215	28	25	22	20	18	5	5	5		
260	28	24	20	16	12	5	5	5		
305	25	20	16	12	8	5	4	4		
350	22	16	10	8	6	3.5	3	3		

Lead 2.5

Orientation	Horizontal					Vertical				
	Acceleration (G)									
Speed (mm/s)	0.1	0.3	0.5	0.7	1	0.1	0.3	0.5		
0	40	40	40	35	30	10	10	10		
20	40	40	40	35	30	10	10	10		
40	40	40	40	35	30	10	10	10		
65	40	40	40	35	30	10	10	10		
85	40	40	40	35	30	10	10	10		
105	40	40	35	35	30	10	10	10		
130	40	40	35	30	30	10	10	8		
150	40	35	35	30	30	8	8	7		
175	40	35	35	30	25	7.5	7	6		

■ RCP6/RCP6S-RR6R

Lead 20

Orientation	Horizontal				Vertical			
	Acceleration (G)							
Speed (mm/s)	0.1	0.3	0.5	0.7	1	0.1	0.3	0.5
0	6	6	6	5	5	1.5	1.5	1.5
160	6	6	6	5	5	1.5	1.5	1.5
320	6	6	6	5	3	1.5	1.5	1.5
480	6	6	6	5	3	1.5	1.5	1.5
640	6	4	3	2		1.5	1.5	
800	4	3				1	1	

Lead 12

Orientation	Horizontal					Vertical				
	Acceleration (G)									
Speed (mm/s)	0.1	0.3	0.5	0.7	1	0.1	0.3	0.5		
0	25	25	18	16	12	4	4	4		
100	25	25	18	16	12	4	4	4		
200	25	25	18	16	10	4	4	4		
300	25	25	18	12	8	4	4	4		
400	20	20	14	10	6	4	4	4		
500	15	15	8	6	4	4	3.5	3		
600	10	10	6	3	2	4	3	2		
700		6	2				2	1		

Lead 6

Orientation	Horizontal					Vertical				
	Acceleration (G)									
Speed (mm/s)	0.1	0.3	0.5	0.7	1	0.1	0.3	0.5		
0	40	40	35	30	25	10	10	10		
50	40	40	35	30	25	10	10	10		
100	40	40	35	30	25	10	10	10		
150	40	40	35	25	25	10	10	10		
200	40	40	30	25	20	10	10	10		
250	40	40	27.5	22.5	18	10	9	8		
300	40	35	25	20	14	6	6	6		
350	40	30	14	12	10	5	5	5		
400	30	18	10	6	5	4	3	3		
450	25	8	3			2	2	1		

Lead 3

Orientation	Horizontal					Vertical				
	Acceleration (G)									
Speed (mm/s)	0.1	0.3	0.5	0.7	1	0.1	0.3	0.5		
0	60	60	50	45	40	20	20	20		
25	60	60	50	45	40	20	20	20		
50	60	60	50	45	40	20	20	20		
75	60	60	50	45	40	20	20	20		
100	60	60	50	45	40	20	20	20		
125	60	60	50	40	30	18	14	10		
150	60	50	40	30	25	14	10	6		
175	60	40	35	25	20	12	6	5		
200	60	35	30	20	14	8	5	4.5		
225	40	16	16	10	6	5	5	4		

■ RCP6/RCP6S-RR7R

Lead 24

Orientation	Horizontal				Vertical			
	Acceleration (G)							
Speed (mm/s)	0.1	0.3	0.5	0.7	1	0.1	0.3	0.5
0	20	20	18	15	12	3	3	3
200	20	20	18	15	12	3	3	3
420	20	20	18	15	10	3	3	3
640	15	14	9	7	4	3	3	2
860	3	1						

Lead 16

Orientation	Horizontal					Vertical				
	Acceleration (G)									
Speed (mm/s)	0.1	0.3	0.5	0.7	1	0.1	0.3	0.5		
0	50	50	40	35	30	8	8	8		
140	50	50	40	35	30	8	8	8		
280	50	50	35	25	20	8	7	7		
420	50	25	18	14	10	4.5	4.5	4		
560	12	10	5	3	2	2	1	1		

Lead 8

Orientation	Horizontal					Vertical				
	Acceleration (G)									
Speed (mm/s)	0.1	0.3	0.5	0.7	1	0.1	0.3	0.5		
0	60	60	50	45	40	18	18	18		
70	60	60	50	45	40	18	18	18		
140	60	60	50	45	40	16	16	12		
210	60	60	40	31	26	10	10	9		
280	60	26	16	10	8	6	5	3		
350	30	3				3	1			
420	2									

Lead 4

Orientation	Horizontal					Vertical				
	Acceleration (G)									
Speed (mm/s)	0.1	0.3	0.5	0.7	1	0.1	0.3	0.5		
0	80	80	70	65	60	28	28	28		
35	80	80	70	65	60	28	28	28		
70	80	80	70	65	60	28	28	28		
105	80	80	60	50	40	22	20	18		
140	80	50	10	6	6	13	8	3		
175	40	5				3				

■ RCP6/RCP6S-RR8R

Lead 20

Orientation	Horizontal				Vertical			
	Acceleration (G)							
Speed (mm/s)	Acceleration (G)				Acceleration (G)			
0	0.2				0.2			
300	30				5			
350	14				3.5			
400	6				2			
					0.5			

Lead 10

Orientation	Horizontal				Vertical			
	Acceleration (G)							
Speed (mm/s)	Acceleration (G)				Acceleration (G)			
0	0.2				0.2			
0	60				40			
160	60				40			
170	40				34			
180	25				28			
190	15				23			
200	12				18			
					15			
					12			
					10			
					8			
					6			
					4			
					3			
					2			

Lead 5

Orientation	Horizontal				Vertical			
	Acceleration (G)							
Speed (mm/s)	Acceleration (G)				Acceleration (G)			
0	0.1				0.1			
0	100				70			
90								

High-output Setting Disabled

■ RCP6/RCP6S-RR4R

Lead 16

Orientation	Horizontal					Vertical				
Speed (mm/s)	Acceleration (G)									
	0.1	0.3	0.5	0.7	1	0.1	0.3	0.5	0.7	1
0	5			3						1
140	5			3						1
280	5			3						1
420	4			2.5						0.5
560	3			1.5						0.5

Lead 10

Orientation	Horizontal					Vertical				
Speed (mm/s)	Acceleration (G)									
	0.1	0.3	0.5	0.7	1	0.1	0.3	0.5	0.7	1
0	10			8						2
85	10			8						2
175	10			8						2
260	9			7						2
350	7			5						1.5
435	6			3						1
525	1									0.5

Lead 5

Orientation	Horizontal					Vertical				
Speed (mm/s)	Acceleration (G)									
	0.1	0.3	0.5	0.7	1	0.1	0.3	0.5	0.7	1
0	22			20						5
40	22			20						5
85	22			20						5
130	22			18						5
175	20			14						4
215	15			10						3
260	12			6						2

Lead 2.5

Orientation	Horizontal					Vertical				
Speed (mm/s)	Acceleration (G)									
	0.1	0.3	0.5	0.7	1	0.1	0.3	0.5	0.7	1
0	35			30						10
20	35			30						10
40	35			30						10
65	35			25						10
85	30			20						7
105	25			15						5
130	20			10						4

■ RCP6/RCP6S-RR6R

Lead 20

Orientation	Horizontal					Vertical				
Speed (mm/s)	Acceleration (G)									
	0.1	0.3	0.5	0.7	1	0.1	0.3	0.5	0.7	1
0	6			5						1
160	6			5						1
320	6			5						1
480	4			3						1
640	3			1						0.5

Lead 12

Orientation	Horizontal					Vertical				
Speed (mm/s)	Acceleration (G)									
	0.1	0.3	0.5	0.7	1	0.1	0.3	0.5	0.7	1
0	25			10						4
100	25			10						4
200	25			10						4
300	20			8						3
400	10			5						2
500	5			2						1

Lead 6

Orientation	Horizontal					Vertical				
Speed (mm/s)	Acceleration (G)									
	0.1	0.3	0.5	0.7	1	0.1	0.3	0.5	0.7	1
0	40			20						10
50	40			20						10
100	40			20						10
150	40			20						8
200	35			18						5
250	10			6						3

Lead 3

Orientation	Horizontal					Vertical				
Speed (mm/s)	Acceleration (G)									
	0.1	0.3	0.5	0.7	1	0.1	0.3	0.5	0.7	1
0	40			25						20
25	40			25						20
50	40			25						20
75	40			25						12
100	40			25						9
125	40			25						5

■ RCP6/RCP6S-RR7R

Lead 24

Orientation	Horizontal					Vertical				
Speed (mm/s)	Acceleration (G)									
	0.1	0.3	0.5	0.7	1	0.1	0.3	0.5	0.7	1
0	18			9.5						3
200	18			9.5						3
420	10			5						1.5
600	1									

Lead 16

Orientation	Horizontal					Vertical				
Speed (mm/s)	Acceleration (G)									
	0.1	0.3	0.5	0.7	1	0.1	0.3	0.5	0.7	1
0	40			25						5
140	40			25						5
280	18			12						2
420	1.5			1						

Lead 8

Orientation	Horizontal					Vertical				
Speed (mm/s)	Acceleration (G)									
	0.1	0.3	0.5	0.7	1	0.1	0.3	0.5	0.7	1
0	50			30						17.5
70	50			30						17.5
140	50			30						7
210	14			7						2

Lead 4

Orientation	Horizontal					Vertical				
Speed (mm/s)	Acceleration (G)									
	0.1	0.3	0.5	0.7	1	0.1	0.3	0.5	0.7	1
0	55			50						26
35	55			50						26
70	55			50						13
105	30			15						2

Tables of Payload by Speed/Acceleration

RCP6 Series

Rod Type Motor Coupling Specification

* Dust-proof/splash-proof specifications have different specs.

High-output Setting Enabled

■ RCP6/RCP6S-WRA10C

Lead 16

Orientation	Horizontal				
	Acceleration (G)				
Speed (mm/s)	0.1	0.3	0.5	0.7	1
0	4	4	3.5	2.5	1.5
140	4	4	3.5	2.5	1.5
280	4	4	3.5	2.5	1
420	4	4	3.5	2	0.5
560		2.5	2.5		
700			0.5		

Lead 10

Orientation	Horizontal				
	Acceleration (G)				
Speed (mm/s)	0.1	0.3	0.5	0.7	1
0	14.5	14.5	13	12.5	12
85	14.5	14.5	13	12.5	12
175	14.5	14.5	12.5	11.5	9.5
260	14.5	14.5	12.5	8.5	6.5
350	14.5	14.5	11.5	7.5	3.5
435	14.5	12.5	7.5	4.5	2.5
525	10.5	7.5	2.5	0.5	

Lead 5

Orientation	Horizontal					Vertical		
	Acceleration (G)							
Speed (mm/s)	0.1	0.3	0.5	0.7	1	0.1	0.3	0.5
0	28	25	22	20	20	5	5	5
40	28	25	22	20	20	5	5	5
85	28	25	22	20	20	5	5	5
130	28	25	22	20	20	5	5	5
175	28	25	22	20	20	5	5	5
215	28	25	22	20	13.5	3	3	3
260	28	25	20.5	15.5	12.5	1	1	1
305	28	17.5	13.5	12.5	7.5			
350	28	9.5	5.5	4.5	2.5			

Lead 2.5

Orientation	Horizontal					Vertical		
	Acceleration (G)							
Speed (mm/s)	0.1	0.3	0.5	0.7	1	0.1	0.3	0.5
0	40	40	40	35	30	10	10	10
20	40	40	40	35	30	10	10	10
40	40	40	40	35	30	10	10	10
65	40	40	40	35	30	10	10	10
85	40	40	40	35	30	10	10	10
105	40	40	35	35	30	10	10	10
130	40	40	35	30	30	8.5	8.5	8.5
150	40	35	35	30	30	5.5	5.5	5.5
175	40	33.5	29.5	27.5	17.5	2.5	2.5	0.5

■ RCP6/RCP6S-WRA12C

Lead 20

Orientation	Horizontal				
	Acceleration (G)				
Speed (mm/s)	0.1	0.3	0.5	0.7	1
0	7.5	7.5	5.5	5.5	5.5
160	7.5	7.5	5.5	5.5	5.5
320	7.5	7.5	4.5	2.5	1.5
480	7.5	4.5	3.5	0.5	0.5
640		4.5	3.5		
800		0.5	0.5		

Lead 12

Orientation	Horizontal				
	Acceleration (G)				
Speed (mm/s)	0.1	0.3	0.5	0.7	1
0	30	25	18	16	12
80	30	25	18	16	12
200	30	25	18	16	10
320	30	25	18	12	8
440	25	20	13.5	10	6
560		15	8	6	4

Lead 6

Orientation	Horizontal					Vertical		
	Acceleration (G)							
Speed (mm/s)	0.1	0.3	0.5	0.7	1	0.1	0.3	0.5
0	55	40	35	30	25	7.5	7.5	7.5
40	55	40	35	30	25	7.5	7.5	7.5
100	55	40	35	30	25	7.5	7.5	7.5
160	55	40	32.5	25	25	7.5	7.5	7.5
220	55	40	27.5	25	19.5	7.5	7.5	6.5
280	55	35	25	20	14	4.5	4.5	4.5
340	55	25.5	14	12	10	0.5		
400	45	12.5	10	6	3.5			

Lead 3

Orientation	Horizontal					Vertical		
	Acceleration (G)							
Speed (mm/s)	0.1	0.3	0.5	0.7	1	0.1	0.3	0.5
0	70	60	50	45	40	17.5	17.5	17.5
20	70	60	50	45	40	17.5	17.5	17.5
50	70	60	50	45	40	17.5	17.5	17.5
80	70	60	50	45	40	17.5	17.5	17.5
110	70	60	50	45	40	17.5	17.5	17.5
140	70	50	40	30	25	13.5	13.5	6
170	70	40	35	25	20	3.5	3.5	3.5
200	70	35	30	20	14	1	1	1
225	50	16	16	10	6			

■ RCP6/RCP6S-WRA14C

Lead 24

Orientation	Horizontal				
	Acceleration (G)				
Speed (mm/s)	0.1	0.3	0.5	0.7	1
0	25	22	14	12	12
210	25	22	14	12	12
420	25	18	14	6	5
630	20	8	2		

Lead 16

Orientation	Horizontal				
	Acceleration (G)				
Speed (mm/s)	0.1	0.3	0.5	0.7	1
0	50	50	40	35	30
140	50	50	40	35	30
280	50	50	31	25	20
420	50	25	14	8	6
560	10	6			

Lead 8

Orientation	Horizontal					Vertical		
	Acceleration (G)							
Speed (mm/s)	0.1	0.3	0.5	0.7	1	0.1	0.3	0.5
0	65	65	55	50	45	15	15	15
70	65	65	55	50	45	15	15	15
140	65	65	55	50	45	15	15	11
210	65	65	40	30	25	7	5	4
280	65	30	17	9	3			
350	50	7						
420	7							

Lead 4

Orientation	Horizontal					Vertical		
	Acceleration (G)							
Speed (mm/s)	0.1	0.3	0.5	0.7	1	0.1	0.3	0.5
0	85	80	70	65	60	25	25	25
35	85	80	70	65	60	25	25	25
70	85	80	70	65	60	25	25	25
105	85	80	60	50	40	21	19	17
130	85	50	30	20	15	11	9	7
175	55	11						
210	15							

■ RCP6/RCP6S-WRA16C

* WRA16C does not have high output enable/disable settings.

Lead 20

Orientation	Horizontal
Speed (mm/s)	Acceleration (G)
	0.2
0	30
240	30
300	30
360	24
420	14
450	5

Lead 10

Orientation	Horizontal	Orientation	Vertical
Speed (mm/s)	Acceleration (G)	Speed (mm/s)	Acceleration (G)
	0.2		0.2
0	60	0	36.5
150	60	88	36.5
200	45	100	29.5
240	36	110	24.5
		120	19.5
		130	16.5
		140	14.5
		150	11
		160	9.5
		170	5.5
		180	4.5
		190	2.5
		200	0.5

Lead 5

Orientation	Horizontal	Orientation	Vertical
Speed (mm/s)	Acceleration (G)	Speed (mm/s)	Acceleration (G)
	0.1		0.1
0	100	0	70
90	100	48	70
120	58	60	50
130	24	70	35
		80	25
		90	20
		100	13

High-output Setting Disabled

■ RCP6/RCP6S-WRA10C

Lead 16

Orientation	Horizontal				
	Acceleration (G)				
Speed (mm/s)	0.1	0.3	0.5	0.7	1
0	3.5	0.5			
140	3.5	0.5			
280	3.5	0.5			
420	3.5	0.5			
560	2.5				

Lead 10

Orientation	Horizontal				
	Acceleration (G)				
Speed (mm/s)	0.1	0.3	0.5	0.7	1
0	9.5	8			
85	9.5	8			
175	9.5	8			
260	9.5	6.5			
350	7.5	6			
435	5	2.5			

Lead 5

Orientation	Horizontal		Vertical					
	Acceleration (G)							
Speed (mm/s)	0.1	0.3	0.5	0.7	1	0.1	0.3	0.5
0	25	19				5		
40	25	19				5		
85	25	19				5		
130	25	19				5		
175	25	15.5				4		
215	18	12				2.5		
260	10.5	6.5						

Lead 2.5

Orientation	Horizontal			Vertical				
	Acceleration (G)							
Speed (mm/s)	0.1	0.3	0.5	0.7	1	0.1	0.3	0.5
0	40	27				10		
20	40	27				10		
40	36	27				10		
65	36	27				10		
85	36	27				8.5		
105	36	27				6		
130	33	22.5				3.5		

■ RCP6/RCP6S-WRA12C

Lead 20

Orientation	Horizontal				
	Acceleration (G)				
Speed (mm/s)	0.1	0.3	0.5	0.7	1
0	7.5	5.5			
160	7.5	5.5			
320	7.5	2.5			
480	3	0.5			

Lead 12

Orientation	Horizontal				
	Acceleration (G)				
Speed (mm/s)	0.1	0.3	0.5	0.7	1
0	18.5	10.5			
80	18.5	10.5			
200	18.5	9.5			
320	15	7			
440	3	1.5			

Lead 6

Orientation	Horizontal		Vertical					
	Acceleration (G)							
Speed (mm/s)	0.1	0.3	0.5	0.7	1	0.1	0.3	0.5
0	39	30				6		
40	39	30				6		
100	39	30				6		
160	39	24				5		
220	24	15				2		

Lead 3

Orientation	Horizontal			Vertical				
	Acceleration (G)							
Speed (mm/s)	0.1	0.3	0.5	0.7	1	0.1	0.3	0.5
0	60	45				13		
20	60	45				13		
50	60	45				13		
80	60	45				12		
110	60	45				6		

■ RCP6/RCP6S-WRA14C

Lead 24

Orientation	Horizontal				
	Acceleration (G)				
Speed (mm/s)	0.1	0.3	0.5	0.7	1
0	18	9.5			
210	18	9.5			
420	8	3			

Lead 16

Orientation	Horizontal				
	Acceleration (G)				
Speed (mm/s)	0.1	0.3	0.5	0.7	1
0	37	27			
140	37	27			
280	18	13			
420	3.5				

Lead 8

Orientation	Horizontal		Vertical					
	Acceleration (G)							
Speed (mm/s)	0.1	0.3	0.5	0.7	1	0.1	0.3	0.5
0	45	33				12		
70	45	33				12		
140	45	27				6		
210	12	4.5						

Lead 4

Orientation	Horizontal			Vertical				
	Acceleration (G)							
Speed (mm/s)	0.1	0.3	0.5	0.7	1	0.1	0.3	0.5
0	57	48				18		
35	57	48				18		
70	57	48				13.5		
105	12	7.5				1		

Tables of Payload by Speed/Acceleration

RCP6 Series

Rod Type Side-Mounted Motor Specification

* Dust-proof/splash-proof specifications have different specs.

High-output Setting Enabled

■ RCP6/RCP6S-WRA10R

Lead 16

Orientation	Horizontal				
Speed (mm/s)	Acceleration (G)				
	0.1	0.3	0.5	0.7	1
0	4	3.5	2.5	0.5	
140	4	3.5	2.5	0.5	
280	4	3.5	2.5	0.5	
420	4	3.5	2.5	0.5	
560		2.5	2		
700			0.5		

Lead 10

Orientation	Horizontal				
Speed (mm/s)	Acceleration (G)				
	0.1	0.3	0.5	0.7	1
0	11.5	11.5	8.5	8.5	6.5
85	11.5	11.5	8.5	8.5	6.5
175	11.5	11.5	8.5	8.5	3.5
260	11.5	11.5	8.5	7.5	2.5
350	11.5	11.5	8.5	6.5	2.5
435	11.5	8.5	6.5	3.5	1.5
525	10.5	6.5	2.5	0.5	

Lead 5

Orientation	Horizontal					Vertical		
Speed (mm/s)	Acceleration (G)							
	0.1	0.3	0.5	0.7	1	0.1	0.3	0.5
0	28	25	22	20	20	5	5	5
40	28	25	22	20	20	5	5	5
85	28	25	22	20	20	5	5	5
130	28	25	22	20	20	5	5	5
175	28	25	22	20	20	5	5	5
215	28	25	22	20	13.5	3	3	3
260	28	25	20.5	15.5	12.5	1	1	1
305	28	17.5	12.5	10.5	7.5			
350	28	9.5	5.5	3.5	0.5			

Lead 2.5

Orientation	Horizontal					Vertical		
Speed (mm/s)	Acceleration (G)							
	0.1	0.3	0.5	0.7	1	0.1	0.3	0.5
0	40	40	40	35	30	10	10	10
20	40	40	40	35	30	10	10	10
40	40	40	40	35	30	10	10	10
65	40	40	40	35	30	10	10	10
85	40	40	40	35	30	10	10	10
105	40	40	35	35	30	10	10	10
130	40	40	35	30	30	3.5	3.5	3.5
150	40	35	35	30	30	1.5	1.5	1.5
175	40	33.5	29.5	25.5	17.5			

■ RCP6/RCP6S-WRA12R

Lead 20

Orientation	Horizontal				
Speed (mm/s)	Acceleration (G)				
	0.1	0.3	0.5	0.7	1
0	7.5	7.5	5.5	5.5	5.5
160	7.5	7.5	5.5	5.5	5.5
320	7.5	7.5	4.5	2.5	1.5
480	7.5	4.5	3.5	0.5	0.5
640		4.5	3.5		
800		0.5	0.5		

Lead 12

Orientation	Horizontal				
Speed (mm/s)	Acceleration (G)				
	0.1	0.3	0.5	0.7	1
0	30	25	18	16	10
80	30	25	18	16	10
200	30	25	18	16	10
320	30	25	18	12	8
440	25	20	13.5	10	6
560		13.5	8	5.5	3.5

Lead 6

Orientation	Horizontal					Vertical		
Speed (mm/s)	Acceleration (G)							
	0.1	0.3	0.5	0.7	1	0.1	0.3	0.5
0	55	40	35	30	25	7.5	7.5	7.5
40	55	40	35	30	25	7.5	7.5	7.5
100	55	40	35	30	25	7.5	7.5	7.5
160	55	40	32.5	25	25	7.5	7.5	7.5
220	55	40	27.5	25	19.5	7.5	7.5	6.5
280	55	35	25	20	14	3.5	3.5	3.5
340	55	25.5	14	12	10			
400	45	12.5	10	6	3.5			

Lead 3

Orientation	Horizontal					Vertical		
Speed (mm/s)	Acceleration (G)							
	0.1	0.3	0.5	0.7	1	0.1	0.3	0.5
0	70	60	50	45	40	17.5	17.5	17.5
20	70	60	50	45	40	17.5	17.5	17.5
50	70	60	50	45	40	17.5	17.5	17.5
80	70	60	50	45	40	17.5	17.5	17.5
110	70	60	50	45	40	17.5	17.5	17.5
140	70	50	40	30	25	13.5	10	6
170	70	40	35	25	20	3.5	3.5	3.5
200	70	35	30	20	14	1	1	0.5
225	50	16	16	10	6			

■ RCP6/RCP6S-WRA14R

Lead 24

Orientation	Horizontal				
Speed (mm/s)	Acceleration (G)				
	0.1	0.3	0.5	0.7	1
0	25	22	14	12	8
210	25	22	14	12	8
420	25	18	14	6	3
630		8	2		

Lead 16

Orientation	Horizontal				
Speed (mm/s)	Acceleration (G)				
	0.1	0.3	0.5	0.7	1
0	50	50	40	35	30
140	50	50	40	35	30
280	50	46	31	22	18
420	50	22	12	8	6
560	10	2			

Lead 8

Orientation	Horizontal					Vertical		
Speed (mm/s)	Acceleration (G)							
	0.1	0.3	0.5	0.7	1	0.1	0.3	0.5
0	65	65	55	50	45	15	15	15
70	65	65	55	50	45	15	15	15
140	65	65	55	50	45	13	13	10
210	65	65	40	30	23	5	5	4
280	65	25	13	7	3			
350	35							

Lead 4

Orientation	Horizontal					Vertical		
Speed (mm/s)	Acceleration (G)							
	0.1	0.3	0.5	0.7	1	0.1	0.3	0.5
0	85	80	70	65	60	25	23	23
35	85	80	70	65	60	25	23	23
70	85	80	70	65	60	25	23	23
105	85	80	60	50	40	19	17	17
130	85	50	10	6	6	7	4	
175	45							

■ RCP6/RCP6S-WRA16R

* WRA16R does not have high output enable/disable settings.

Lead 20

Orientation	Horizontal
Speed (mm/s)	Acceleration (G)
0	30
240	30
300	30
360	19
420	10.5

Lead 10

Orientation	Horizontal	Orientation	Vertical
Speed (mm/s)	Acceleration (G)	Speed (mm/s)	Acceleration (G)
			0.2
0	60	0	34.5
150	60	88	34.5
200	45	100	24.5
240	18	110	19.5
		120	16.5
		130	14.5
		140	11.5
		150	7.5
		160	5.5
		170	4.5
		180	2.5

Lead 5

Orientation	Horizontal	Orientation	Vertical
Speed (mm/s)	Acceleration (G)	Speed (mm/s)	Acceleration (G)
			0.1
0	100	0	63
90	100	48	63
120	58	60	33
		70	28
		80	18
		90	9
		100	2

High-output Setting Disabled

■ RCP6/RCP6S-WRA10R

Lead 16

Orientation	Horizontal				
	Acceleration (G)				
Speed (mm/s)	0.1	0.3	0.5	0.7	1
0	3.5	0.5			
140	3.5	0.5			
280	3.5	0.5			
420	3.5	0.5			
560	2.5				

Lead 10

Orientation	Horizontal				
	Acceleration (G)				
Speed (mm/s)	0.1	0.3	0.5	0.7	1
0	9.5	8			
85	9.5	8			
175	9.5	8			
260	9.5	6.5			
350	7.5	6			
435	5	2.5			

Lead 5

Orientation	Horizontal		Vertical					
	Acceleration (G)							
Speed (mm/s)	0.1	0.3	0.5	0.7	1	0.1	0.3	0.5
0	25	19				5		
40	25	19				5		
85	25	19				5		
130	25	19				5		
175	25	15.5				4		
215	18	12				2.5		
260	10.5	6.5						

Lead 2.5

Orientation	Horizontal			Vertical				
	Acceleration (G)							
Speed (mm/s)	0.1	0.3	0.5	0.7	1	0.1	0.3	0.5
0	40	27				10		
20	40	27				10		
40	36	27				10		
65	36	27				10		
85	36	27				8.5		
105	36	27				6		
130	33	22.5				3.5		

■ RCP6/RCP6S-WRA12R

Lead 20

Orientation	Horizontal				
	Acceleration (G)				
Speed (mm/s)	0.1	0.3	0.5	0.7	1
0	7.5	5.5			
160	7.5	5.5			
320	7.5	2.5			
480	3	0.5			

Lead 12

Orientation	Horizontal				
	Acceleration (G)				
Speed (mm/s)	0.1	0.3	0.5	0.7	1
0	18.5	10.5			
80	18.5	10.5			
200	18.5	9.5			
320	15	7			
440	3	1.5			

Lead 6

Orientation	Horizontal		Vertical					
	Acceleration (G)							
Speed (mm/s)	0.1	0.3	0.5	0.7	1	0.1	0.3	0.5
0	39	30				6		
40	39	30				6		
100	39	30				6		
160	39	24				5		
220	24	15				2		

Lead 3

Orientation	Horizontal			Vertical				
	Acceleration (G)							
Speed (mm/s)	0.1	0.3	0.5	0.7	1	0.1	0.3	0.5
0	60	45				13		
20	60	45				13		
50	60	45				13		
80	60	45				12		
110	60	45				6		

■ RCP6/RCP6S-WRA14R

Lead 24

Orientation	Horizontal				
	Acceleration (G)				
Speed (mm/s)	0.1	0.3	0.5	0.7	1
0	18	9.5			
210	18	9.5			
420	8	3			

Lead 16

Orientation	Horizontal				
	Acceleration (G)				
Speed (mm/s)	0.1	0.3	0.5	0.7	1
0	37	27			
140	37	27			
280	18	13			
420	3.5				

Lead 8

Orientation	Horizontal		Vertical					
	Acceleration (G)							
Speed (mm/s)	0.1	0.3	0.5	0.7	1	0.1	0.3	0.5
0	45	33				12		
70	45	33				12		
140	45	27				6		
210	12	4.5						

Lead 4

Orientation	Horizontal			Vertical				
	Acceleration (G)							
Speed (mm/s)	0.1	0.3	0.5	0.7	1	0.1	0.3	0.5
0	57	48				18		
35	57	48				18		
70	57	48				13.5		
105	12	7.5				1		

Tables of Payload by Speed/Acceleration

RCP6 Series

Rod Type Motor Coupling Specification

* Dust-proof/splash-proof specifications have different specs.

High-output Setting Enabled

■ RCP6/RCP6S-RA4C

Lead 16

Orientation	Horizontal				Vertical			
	Acceleration (G)							
Speed (mm/s)	0.1	0.3	0.5	0.7	1	0.1	0.3	0.5
0	6	6	6	4	3.5	1.5	1.5	1.5
140	6	6	6	4	3.5	1.5	1.5	1.5
280	6	6	6	4	3.5	1.5	1.5	1.5
420	6	6	6	4	3	1	1	1
560	6	6	3	3				
700		5.5	5	2	1.5		1	1
840			3	1	0.5			1

Lead 10

Orientation	Horizontal				Vertical			
	Acceleration (G)							
Speed (mm/s)	0.1	0.3	0.5	0.7	1	0.1	0.3	0.5
0	15	15	13	13	12	2.5	2.5	2.5
85	15	15	13	13	12	2.5	2.5	2.5
175	15	15	13	13	12	2.5	2.5	2.5
260	15	15	13	13	12	2.5	2.5	2.5
350	15	15	13	13	10	2.5	2.5	2.5
435	15	15	13	11	8	2.5	2.5	2.5
525		14	10	8	6		2.5	2.5
610		9	7	5	4		2	2
700		6	4	3	2		1.5	1.5

Lead 5

Orientation	Horizontal				Vertical			
	Acceleration (G)							
Speed (mm/s)	0.1	0.3	0.5	0.7	1	0.1	0.3	0.5
0	28	25	22	20	20	5	5	5
40	28	25	22	20	20	5	5	5
85	28	25	22	20	20	5	5	5
130	28	25	22	20	20	5	5	5
175	28	25	22	20	20	5	5	5
215	28	25	22	20	20	5	5	5
260	28	25	22	20	18	5	5	5
305	28	22	20	18	15	5	5	4.5
350	28	20	15	13	11	5	4	3.5

Lead 2.5

Orientation	Horizontal				Vertical			
	Acceleration (G)							
Speed (mm/s)	0.1	0.3	0.5	0.7	1	0.1	0.3	0.5
0	40	40	40	35	30	10	10	10
20	40	40	40	35	30	10	10	10
40	40	40	40	35	30	10	10	10
65	40	40	40	30	30	10	10	10
85	40	40	40	30	30	10	10	10
105	40	40	35	30	30	10	10	10
130	40	40	35	30	30	8	7.5	7
150	40	35	35	30	25	6	5.5	5
175	40	30	30	25	20	5	4.5	4

■ RCP6/RCP6S-RA6C

Lead 20

Orientation	Horizontal				Vertical			
	Acceleration (G)							
Speed (mm/s)	0.1	0.3	0.5	0.7	1	0.1	0.3	0.5
0	6	6	6	5	5	1.5	1.5	1.5
160	6	6	6	5	5	1.5	1.5	1.5
320	6	6	6	5	3	1.5	1.5	1.5
480	6	6	6	5	3	1.5	1.5	1.5
640	6	4	3	2		1.5	1.5	1.5
800		4	3			1	1	1

Lead 12

Orientation	Horizontal				Vertical			
	Acceleration (G)							
Speed (mm/s)	0.1	0.3	0.5	0.7	1	0.1	0.3	0.5
0	25	25	18	16	12	4	4	4
100	25	25	18	16	12	4	4	4
200	25	25	18	16	10	4	4	4
300	25	25	18	12	8	4	4	4
400	20	20	14	10	6	4	4	4
500	15	15	8	6	4	4	3.5	3
600		10	6	3	2		3	2
700		6	2				2	1

Lead 6

Orientation	Horizontal				Vertical			
	Acceleration (G)							
Speed (mm/s)	0.1	0.3	0.5	0.7	1	0.1	0.3	0.5
0	40	40	35	30	25	10	10	10
50	40	40	35	30	25	10	10	10
100	40	40	35	30	25	10	10	10
150	40	40	35	25	25	10	10	10
200	40	40	30	25	20	10	10	10
250	40	40	27.5	22.5	18	10	9	8
300	40	35	25	20	14	6	6	6
350	40	30	14	12	10	5	5	5
400	30	18	10	6	5	4	3	3
450	25	8	3			2	2	1

Lead 3

Orientation	Horizontal				Vertical			
	Acceleration (G)							
Speed (mm/s)	0.1	0.3	0.5	0.7	1	0.1	0.3	0.5
0	60	60	50	45	40	20	20	20
50	60	60	50	45	40	20	20	20
75	60	60	50	45	40	20	20	20
100	60	60	50	45	40	20	20	20
125	60	60	50	40	30	18	14	10
150	60	50	40	30	25	14	10	6
175	60	40	35	25	20	12	6	5
200	60	35	30	20	14	8	5	4.5
225	40	16	16	10	6	5	5	4

■ RCP6/RCP6S-RA7C

Lead 24

Orientation	Horizontal				Vertical			
	Acceleration (G)							
Speed (mm/s)	0.1	0.3	0.5	0.7	1	0.1	0.3	0.5
0	20	20	18	15	12	3	3	3
200	20	20	18	15	12	3	3	3
400	20	20	14	12	8	3	3	3
420	20	17	12	10	6	3	3	3
600		14	6	5	4		3	2
640		5	3	2	1.5		2	1
800		5	1	1				
860		2	0.5					

Lead 16

Orientation	Horizontal				Vertical			
	Acceleration (G)							
Speed (mm/s)	0.1	0.3	0.5	0.7	1	0.1	0.3	0.5
0	50	50	40	35	30	8	8	8
140	50	50	40	35	30	8	8	8
280	50	50	35	25	20	8	7	7
420	50	25	18	14	10	6	4.5	4
560		10	5	3	2		2	1
700		2						

Lead 8

Orientation	Horizontal				Vertical			
	Acceleration (G)							
Speed (mm/s)	0.1	0.3	0.5	0.7	1	0.1	0.3	0.5
0	60	60	50	45	40	18	18	18
70	60	60	50	45	40	18	18	18
140	60	60	50	45	40	16	16	12
210	60	60	40	31	26	10	10	9
280	60	34	20	15	11	7	5	4
350	50	12	4	1		3	2	1
420	10							

Lead 4

Orientation	Horizontal				Vertical			
	Acceleration (G)							
Speed (mm/s)	0.1	0.3	0.5	0.7	1	0.1	0.3	0.5
0	80	80	70	65	60	28	28	28
35	80	80	70	65	60	28	28	28
70	80	80	70	65	60	28	28	28
105	80	80	60	50	40	22	22	18
140	80	50	30	20	15	14	12	10
175	50	15				5	2	
210	20							

■ RCP6/RCP6S-RA8C

* RA8C does not have high output enable/disable settings.

Lead 20

Orientation	Horizontal		Orientation	Vertical	
	Acceleration (G)			Acceleration (G)	
Speed (mm/s)	0.2		Speed (mm/s)	0.2	
0	30		0	5	
240	30		50	5	
270	30		100	5	
300	30		150	5	
360	24		180	5	
420	16		200	5	
450	12		240	5	
480	10		300	5	
510	8		360	5	
540	6		400	3	
600	5		420	2.5	
			450	2	

Lead 10

Orientation	Horizontal		Orientation	Vertical	
	Acceleration (G)			Acceleration (G)	
Speed (mm/s)	0.2		Speed (mm/s)	0.2	
0	60		0	40	
150	60		88	40	
200	45		100	33	
240	40		110	28	
300	10		120	23	
			130	18	
			140	15	
			150	11	
			160	10	
			170	8	
			180	7	
			190	5	
			200	4	
			220	3	
			250	2	

Lead 5

Orientation	Horizontal		Orientation	Vertical	
	Acceleration (G)			Acceleration (G)	

High-output Setting Disabled

■ RCP6/RCP6S-RA4C

Lead 16

Orientation	Horizontal					Vertical				
	Acceleration (G)									
Speed (mm/s)	0.1	0.3	0.5	0.7	1	0.1	0.3	0.5		
0	5	3				1				
140	5	3				1				
280	5	3				1				
420	4	2.5				0.5				
560	3	1.5				0.5				

Lead 10

Orientation	Horizontal					Vertical				
	Acceleration (G)									
Speed (mm/s)	0.1	0.3	0.5	0.7	1	0.1	0.3	0.5		
0	10	8				2				
85	10	8				2				
175	10	8				2				
260	9	7				2				
350	7	5				1.5				
435	6	3				1				
525	1					0.5				

Lead 5

Orientation	Horizontal					Vertical				
	Acceleration (G)									
Speed (mm/s)	0.1	0.3	0.5	0.7	1	0.1	0.3	0.5		
0	22	20				5				
40	22	20				5				
85	22	20				5				
130	22	18				5				
175	20	14				4				
215	15	10				3				
260	12	6				2				

Lead 2.5

Orientation	Horizontal					Vertical				
	Acceleration (G)									
Speed (mm/s)	0.1	0.3	0.5	0.7	1	0.1	0.3	0.5		
0	35	30				10				
20	35	30				10				
40	35	30				10				
65	35	25				10				
85	30	20				7				
105	25	15				5				
130	20	10				4				

■ RCP6/RCP6S-RA6C

Lead 20

Orientation	Horizontal					Vertical				
	Acceleration (G)									
Speed (mm/s)	0.1	0.3	0.5	0.7	1	0.1	0.3	0.5		
0	6	5				1				
160	6	5				1				
320	6	4				1				
480	4	3				1				
640	3	1				0.5				

Lead 12

Orientation	Horizontal					Vertical				
	Acceleration (G)									
Speed (mm/s)	0.1	0.3	0.5	0.7	1	0.1	0.3	0.5		
0	25	10				4				
100	25	10				4				
200	25	10				4				
300	20	8				3				
400	10	5				2				
500	5	2				1				

Lead 6

Orientation	Horizontal					Vertical				
	Acceleration (G)									
Speed (mm/s)	0.1	0.3	0.5	0.7	1	0.1	0.3	0.5		
0	40	20				10				
50	40	20				10				
100	40	20				10				
150	40	20				8				
200	35	18				5				
250	10	6				3				

Lead 3

Orientation	Horizontal					Vertical				
	Acceleration (G)									
Speed (mm/s)	0.1	0.3	0.5	0.7	1	0.1	0.3	0.5		
0	40	25				20				
50	40	25				20				
75	40	25				12				
100	40	25				9				
125	40	25				5				

■ RCP6/RCP6S-RA7C

Lead 24

Orientation	Horizontal					Vertical				
	Acceleration (G)									
Speed (mm/s)	0.1	0.3	0.5	0.7	1	0.1	0.3	0.5		
0	18	9.5				3				
200	18	9.5				3				
400	11	6				1.5				
420	10	5								
600	1									

Lead 16

Orientation	Horizontal					Vertical				
	Acceleration (G)									
Speed (mm/s)	0.1	0.3	0.5	0.7	1	0.1	0.3	0.5		
0	40	25				5				
140	40	25				5				
280	18	12				2				
420	1.5	1								

Lead 8

Orientation	Horizontal					Vertical				
	Acceleration (G)									
Speed (mm/s)	0.1	0.3	0.5	0.7	1	0.1	0.3	0.5		
0	50	30				17.5				
70	50	30				17.5				
140	50	30				7				
210	14	7				2				

Lead 4

Orientation	Horizontal					Vertical				
	Acceleration (G)									
Speed (mm/s)	0.1	0.3	0.5	0.7	1	0.1	0.3	0.5		
0	55	50				26				
35	55	50				26				
70	55	50				13				
105	30	15				2				

Tables of Payload by Speed/Acceleration

RCP6 Series

Rod Type Side-Mounted Motor Specification

* Dust-proof/splash-proof specifications have different specs.

High-output Setting Enabled

■ RCP6/RCP6S-RA4R

Lead 16

Orientation	Horizontal				Vertical			
	Acceleration (G)							
Speed (mm/s)	0.1	0.3	0.5	0.7	1	0.1	0.3	0.5
0	5	5	4.5	3	2.5	1	1	1
140	5	5	4.5	3	2.5	1	1	1
280	5	5	4.5	3	2	1	1	1
420	5	5	4.5	3	2	1	1	1
560	5	4.5	2.5	2		1	1	
700	4.5	3.5	2	1.5		1	1	
840		2.5	1	0.5				0.5

Lead 10

Orientation	Horizontal					Vertical			
	Acceleration (G)								
Speed (mm/s)	0.1	0.3	0.5	0.7	1	0.1	0.3	0.5	
0	12	12	10	10	8	2.5	2.5	2.5	
85	12	12	10	10	8	2.5	2.5	2.5	
175	12	12	10	10	6	2.5	2.5	2.5	
260	12	12	10	10	5	2.5	2.5	2.5	
350	12	12	10	8	5	2.5	2.5	2.5	
435	12	10	8	6	4	2.5	2.5	2.5	
525		8	6	3	2		2.5	2	
610		5	2				2	1.5	

Lead 5

Orientation	Horizontal					Vertical			
	Acceleration (G)								
Speed (mm/s)	0.1	0.3	0.5	0.7	1	0.1	0.3	0.5	
0	25	25	22	20	18	5	5	5	
40	25	25	22	20	18	5	5	5	
85	25	25	22	20	18	5	5	5	
130	25	25	22	18	18	5	5	5	
175	25	25	22	18	16	5	5	5	
215	25	25	22	16	14	5	5	5	
260	25	22	20	14	12	5	5	5	
305	22	20	14	12	8	4	4	4	
350	20	14	10	8	6	3	2.5	2.5	

Lead 2.5

Orientation	Horizontal					Vertical			
	Acceleration (G)								
Speed (mm/s)	0.1	0.3	0.5	0.7	1	0.1	0.3	0.5	
0	40	40	40	35	30	10	10	10	
20	40	40	40	35	30	10	10	10	
40	40	40	40	35	30	10	10	10	
65	40	40	40	30	30	10	10	10	
85	40	40	35	30	30	10	10	10	
105	40	40	35	30	30	10	8	8	
130	40	40	35	30	30	8	8	8	
150	40	35	35	30	25	6	6	6	
175	40	30	30	25	20	4	4	4	

■ RCP6/RCP6S-RA6R

Lead 20

Orientation	Horizontal				Vertical			
	Acceleration (G)							
Speed (mm/s)	0.1	0.3	0.5	0.7	1	0.1	0.3	0.5
0	6	6	5	5	5	1.5	1.5	1.5
160	6	6	5	5	5	1.5	1.5	1.5
320	6	6	5	4	3	1.5	1.5	1.5
480	6	6	5	4	3	1.5	1.5	1.5
640	4	3	3	2		1.5	1.5	
800	3	2	2	1		1	1	

Lead 12

Orientation	Horizontal					Vertical			
	Acceleration (G)								
Speed (mm/s)	0.1	0.3	0.5	0.7	1	0.1	0.3	0.5	
0	25	25	18	16	12	4	4	4	
100	25	25	18	16	12	4	4	4	
200	25	25	18	16	10	4	4	4	
285	25	25	18	12	8	4	4	4	
400	20	20	14	10	6	4	4	4	
500	15	15	8	6	4	4	3.5	3	
600		10	6	3	2		3	2	
700		6	2				2	1	

Lead 6

Orientation	Horizontal					Vertical			
	Acceleration (G)								
Speed (mm/s)	0.1	0.3	0.5	0.7	1	0.1	0.3	0.5	
0	40	40	35	30	25	10	10	10	
50	40	40	35	30	25	10	10	10	
100	40	40	35	30	25	10	10	10	
150	40	40	35	25	25	10	10	10	
200	40	40	30	25	20	10	10	10	
250	40	40	27.5	22.5	18	10	9	8	
300	40	35	25	20	14	6	6	6	
350	40	25	14	12	10	5	5	5	
400	30	16	10	6	5	4	3	3	
450	25	8	3			2	2	1	

Lead 3

Orientation	Horizontal					Vertical			
	Acceleration (G)								
Speed (mm/s)	0.1	0.3	0.5	0.7	1	0.1	0.3	0.5	
0	60	60	50	45	40	20	20	20	
25	60	60	50	45	40	20	20	20	
50	60	60	50	45	40	20	20	20	
75	60	60	50	45	40	20	20	20	
100	60	60	50	45	40	20	20	20	
125	60	60	50	40	30	18	14	10	
150	60	50	40	30	25	14	10	6	
175	60	40	35	25	20	12	6	5	
200	60	35	30	20	14	8	5	4.5	
225	40	16	16	10	6	5	5	4	

■ RCP6/RCP6S-RA7R

Lead 24

Orientation	Horizontal				Vertical			
	Acceleration (G)							
Speed (mm/s)	0.1	0.3	0.5	0.7	1	0.1	0.3	0.5
0	20	20	18	15	12	3	3	3
200	20	20	18	15	12	3	3	3
400	20	20	16	12	8	3	3	3
420	20	20	15	10	6	3	3	3
600		12	8	5	3		2	2
640		10	6	4	2		1	1
800			2					

Lead 16

Orientation	Horizontal					Vertical			
	Acceleration (G)								
Speed (mm/s)	0.1	0.3	0.5	0.7	1	0.1	0.3	0.5	
0	50	50	40	35	30	8	8	8	
140	50	50	40	35	30	8	8	8	
280	50	50	35	23	20	8	7	7	
420	50	25	18	13	10	4.5	4.5	4	
560		10	5	3	2		1	1	

Lead 8

Orientation	Horizontal					Vertical			
	Acceleration (G)								
Speed (mm/s)	0.1	0.3	0.5	0.7	1	0.1	0.3	0.5	
0	60	60	50	45	40	18	18	18	
70	60	60	50	45	40	18	18	18	
140	60	60	50	45	40	16	16	12	
210	60	60	40	31	26	10	10	9	
280	60	26	16	10	8	8	4	3	
350	30	3				2	0.5		
420	2								

Lead 4

Orientation	Horizontal					Vertical			
	Acceleration (G)								
Speed (mm/s)	0.1	0.3	0.5	0.7	1	0.1	0.3	0.5	
0	80	80	70	65	60	28	28	28	
35	80	80	70	65	60	28	28	28	
70	80	80	70	65	60	28	28	28	
105	80	80	60	50	40	22	20	18	
140	80	50	10	6	6	12	8	3	
175	40	5				4			

■ RCP6/RCP6S-RA8R

* RA8R does not have high output enable/disable settings.

Lead 20

Orientation	Horizontal	Orientation	Vertical
	Acceleration (G)		Acceleration (G)
Speed (mm/s)	0.2	Speed (mm/s)	0.2
0	30	0	5
300	30	300	5
350	14	330	3.5
400	6	360	2
		400	0.5

Lead 10

Orientation	Horizontal	Orientation	Vertical
	Acceleration (G)		Acceleration (G)
Speed (mm/s)	0.2	Speed (mm/s)	0.2
0	60	0	40
160	60	80	40
170	40	90	34
180	25	100	28
190	15	110	23
200	12	120	18
		130	15
		140	12
		150	10
		160	8
		170	6
		180	4
		190	3
		200	2

Lead 5

Orientation	Horizontal	Orientation	Vertical
	Acceleration (G)		Acceleration (G)
Speed (mm/s)	0.1	Speed (mm/s)	0.1
0	100	0	70
90	100	45	70
		60	45
		70	35
		80	25
		90	16
		100	10

High-output Setting Disabled

■ RCP6/RCP6S-RA4R

Lead 16

Orientation	Horizontal					Vertical			
	Acceleration (G)								
Speed (mm/s)	0.1	0.3	0.5	0.7	1	0.1	0.3	0.5	
0	5	3				1			
140	5	3				1			
280	5	3				1			
420	4	2.5				0.5			
560	3	1.5				0.5			

Lead 10

Orientation	Horizontal					Vertical			
	Acceleration (G)								
Speed (mm/s)	0.1	0.3	0.5	0.7	1	0.1	0.3	0.5	
0	10	8				2			
85	10	8				2			
175	10	8				2			
260	9	7				2			
350	7	5				1.5			
435	6	3				1			
525	1					0.5			

Lead 5

Orientation	Horizontal					Vertical			
	Acceleration (G)								
Speed (mm/s)	0.1	0.3	0.5	0.7	1	0.1	0.3	0.5	
0	22	20				5			
40	22	20				5			
85	22	20				5			
130	22	18				5			
175	20	14				4			
215	15	10				3			
260	12	6				2			

Lead 2.5

Orientation	Horizontal					Vertical			
	Acceleration (G)								
Speed (mm/s)	0.1	0.3	0.5	0.7	1	0.1	0.3	0.5	
0	35	30				10			
20	35	30				10			
40	35	30				10			
65	35	25				10			
85	30	20				7			
105	25	15				5			
130	20	10				4			

■ RCP6/RCP6S-RA6R

Lead 20

Orientation	Horizontal					Vertical			
	Acceleration (G)								
Speed (mm/s)	0.1	0.3	0.5	0.7	1	0.1	0.3	0.5	
0	6	5				1			
160	6	5				1			
320	6	4				1			
480	4	3				1			
640	3	1				0.5			

Lead 12

Orientation	Horizontal					Vertical			
	Acceleration (G)								
Speed (mm/s)	0.1	0.3	0.5	0.7	1	0.1	0.3	0.5	
0	25	10				4			
100	25	10				4			
200	25	10				4			
300	20	8				3			
400	10	5				2			
500	5	2				1			

Lead 6

Orientation	Horizontal					Vertical			
	Acceleration (G)								
Speed (mm/s)	0.1	0.3	0.5	0.7	1	0.1	0.3	0.5	
0	40	20				10			
50	40	20				10			
100	40	20				10			
150	40	20				8			
200	35	18				5			
250	10	6				3			

Lead 3

Orientation	Horizontal					Vertical			
	Acceleration (G)								
Speed (mm/s)	0.1	0.3	0.5	0.7	1	0.1	0.3	0.5	
0	40	25				20			
25	40	25				20			
50	40	25				20			
75	40	25				12			
100	40	25				9			
125	40	25				5			

■ RCP6/RCP6S-RA7R

Lead 24

Orientation	Horizontal					Vertical			
	Acceleration (G)								
Speed (mm/s)	0.1	0.3	0.5	0.7	1	0.1	0.3	0.5	
0	18	9.5				3			
200	18	9.5				3			
400	11	6				1.5			
420	10	5							
600	1								

Lead 16

Orientation	Horizontal					Vertical			
	Acceleration (G)								
Speed (mm/s)	0.1	0.3	0.5	0.7	1	0.1	0.3	0.5	
0	40	25				5			
140	40	25				5			
280	18	12				2			
420	1.5	1							

Lead 8

Orientation	Horizontal					Vertical			
	Acceleration (G)								
Speed (mm/s)	0.1	0.3	0.5	0.7	1	0.1	0.3	0.5	
0	50	30				17.5			
70	50	30				17.5			
140	50	30				7			
210	14	7				2			

Lead 4

Orientation	Horizontal					Vertical			
	Acceleration (G)								
Speed (mm/s)	0.1	0.3	0.5	0.7	1	0.1	0.3	0.5	
0	55	50				26			
35	55	50				26			
70	55	50				13			
105	30	15				2			

Tables of Payload by Speed/Acceleration

RCP6 Series

Table Type Motor Coupling Specification Single Block

High-output Setting Enabled

■ RCP6/RCP6S-TA4C

Lead 16

Orientation	Horizontal						Vertical		
	Acceleration (G)								
Speed (mm/s)	0.1	0.3	0.5	0.7	1	0.1	0.3	0.5	
0	3	3	3	3	3	1	1	1	
140	3	3	3	3	3	1	1	1	
280	3	3	3	3	3	1	1	1	
420	3	3	3	3	3	1	1	1	
560	3	3	3	3	3	1	1	1	
700			3	3	3			1	
840				3	3				
980					2				
1120									
1260									

Lead 10

Orientation	Horizontal						Vertical		
	Acceleration (G)								
Speed (mm/s)	0.1	0.3	0.5	0.7	1	0.1	0.3	0.5	
0	4	4	4	4	4	2.5	2.5	2	
85	4	4	4	4	4	2.5	2.5	2	
175	4	4	4	4	4	2.5	2.5	2	
260	4	4	4	4	4	2.5	2.5	2	
350	4	4	4	4	4	2.5	2.5	2	
435	4	4	4	4	4	2.5	2		
525				4	4			2	
610					4			1.5	
700					4			2.5	
785					2.5			2	

Lead 5

Orientation	Horizontal						Vertical		
	Acceleration (G)								
Speed (mm/s)	0.1	0.3	0.5	0.7	1	0.1	0.3	0.5	
0	5	5	5	5	5	5	5	5	
40	5	5	5	5	5	5	5	5	
85	5	5	5	5	5	5	5	5	
130	5	5	5	5	5	5	5	5	
175	5	5	5	5	5	5	5	5	
215	5	5	5	5	5	5	5	5	
260	5	5	5	5	4.5	5	5	5	
305	5	5	5	5	4	4.5	4.5	4.5	
350	5	5	5	4	3.5	4	3.5		
390				5	4		2.5	2.5	

Lead 2.5

Orientation	Horizontal						Vertical		
	Acceleration (G)								
Speed (mm/s)	0.1	0.3	0.5	0.7	1	0.1	0.3	0.5	
0	5	5	5	5	5	10	9	8	
20	5	5	5	5	5	10	9	8	
40	5	5	5	5	5	10	9	8	
65	5	5	5	5	5	10	9	8	
85	5	5	5	5	5	10	9	7	
105	5	5	5	5	5	10	8	7	
130	5	5	5	5	4.5	10	8	6	
150	5	5	5	5	4	9	7	6	
175	5	5	5	4	3.5	8	7		
195	5	5	5	4	3	6	5		

■ RCP6/RCP6S-TA6C

Lead 20

Orientation	Horizontal						Vertical		
	Acceleration (G)								
Speed (mm/s)	0.1	0.3	0.5	0.7	1	0.1	0.3	0.5	
0	5	5	5	5	5	1	1	1	
160	5	5	5	5	5	1	1	1	
320	5	5	5	5	5	1	1	1	
480	5	5	5	5	5	1	1	1	
640	5	5	5	5	5	1	1	1	
800			5	4.5	4			1	
960				3.5	2				
1120					1.5				

Lead 12

Orientation	Horizontal						Vertical		
	Acceleration (G)								
Speed (mm/s)	0.1	0.3	0.5	0.7	1	0.1	0.3	0.5	
0	8	8	8	7	6	3	3	3	
80	8	8	8	7	6	3	3	3	
200	8	8	8	7	6	3	3	3	
320	8	8	8	7	6	3	3	3	
440	8	8	8	7	6	3	3	3	
500			8	7	6			3	
560				8	6			3	
680				8	7			2	
800					5			2	

Lead 6

Orientation	Horizontal						Vertical		
	Acceleration (G)								
Speed (mm/s)	0.1	0.3	0.5	0.7	1	0.1	0.3	0.5	
0	10	10	9	8	7	6	6	6	
40	10	10	9	8	7	6	6	6	
100	10	10	9	8	7	6	6	6	
160	10	10	9	8	7	6	6	6	
220	10	10	9	8	7	6	6	6	
250	10	10	9	8	7	6	6	5.5	
280	10	10	9	8	7	6	5.5	5	
340	10	10	9	8	7	6	4.5	4	
400	10	9	8	7	6	4.5	3.5		

Lead 3

Orientation	Horizontal						Vertical		
	Acceleration (G)								
Speed (mm/s)	0.1	0.3	0.5	0.7	1	0.1	0.3	0.5	
0	10	10	10	8	7	12	12	10	
20	10	10	10	8	7	12	12	10	
50	10	10	10	8	7	12	12	10	
80	10	10	10	8	7	12	12	10	
110	10	10	10	8	7	12	12	10	
125	10	10	10	8	7	12	12	10	
140	10	10	10	8	7	12	12	10	
170	10	10	8	7	6	12	10		
200	10	8	7	6	4	10	8		

■ RCP6/RCP6S-TA7C

Lead 24

Orientation	Horizontal						Vertical		
	Acceleration (G)								
Speed (mm/s)	0.1	0.3	0.5	0.7	1	0.1	0.3	0.5	
0	10	10	10	8	8	3	3	3	
200	10	10	10	8	8	3	3	3	
420	10	10	10	8	8	3	3	3	
640	10	10	8	7		3	3		
860		9	7	6	3		1.5	1	
1080			3.5	2					

Lead 16

Orientation	Horizontal						Vertical		
	Acceleration (G)								
Speed (mm/s)	0.1	0.3	0.5	0.7	1	0.1	0.3	0.5	
0	12	12	12	10	10	7	7	7	
140	12	12	12	10	10	7	7	7	
280	12	12	12	10	10	7	7	6	
420	12	12	12	10	8	6	5	4	
560			12	10	8			3	
700				10	6			2	

Lead 8

Orientation	Horizontal						Vertical		
	Acceleration (G)								
Speed (mm/s)	0.1	0.3	0.5	0.7	1	0.1	0.3	0.5	
0	15	15	15	15	15	16	14	12	
70	15	15	15	15	15	16	14	12	
140	15	15	15	15	12	16	14	10	
210	15	15	15	12	10	12	10	8	
280	15	15	12	10	8	9	8		
350	12	10	8			6			
420	8								

Lead 4

Orientation	Horizontal						Vertical		
	Acceleration (G)								
Speed (mm/s)	0.1	0.3	0.5	0.7	1	0.1	0.3	0.5	
0	15	15	15	15	15	20	20	20	
35	15	15	15	15	15	20	20	20	
70	15	15	15	15	15	20	18	14	
105	15	15	15	15	12	18	16	10	
140	15	15	15	12	10	16	12	6	
175	15	12	10			10	6		
210	10					6			

High-output Setting Disabled

■ RCP6/RCP6S-TA4C

Lead 16

Orientation	Horizontal						Vertical		
	Acceleration (G)								
Speed (mm/s)	0.1	0.3	0.5	0.7	1	0.1	0.3	0.5	
0	3	3	3	3	3	1	1	1	
140	3	3	3	3	3	1	1	1	
280	3	3	3	3	3	1	1	1	
420	3	3	3	3	3	1	1	1	
560	2.5	2				0.75			
700			1.5						
840				1					

Lead 10

Orientation	Horizontal						Vertical		
	Acceleration (G)								
Speed (mm/s)	0.1	0.3	0.5	0.7	1	0.1	0.3	0.5	
0	4	4	4	4	4	2.5			
85	4	4	4	4	4	2.5			
175	4	4	4	4	4	2.5			
260	4	4	4	4	4	2.25			
350	4	4	4	4	4	1.5			
435	4	3.5				1			
525				2					

Lead 5

Orientation	Horizontal						Vertical		
	Acceleration (G)								
Speed (mm/s)	0.1	0.3	0.5	0.7	1	0.1	0.3	0.5	
0	5	5	5	5	5	5			
40	5	5	5	5	5	5			
85	5	5	5	5	5	5			
130	5	5	5	5	5	5			
175	5	5	5	5	4.5	5			
215	5	5	5	5	4	5			
260	5	5	5	5	2.5	5			

Lead 2.5

Orientation	Horizontal						Vertical		
	Acceleration (G)								
Speed (mm/s)	0.1	0.3	0.5	0.7	1	0.1	0.3	0.5	
0	5	5	5	5	5	9			
20	5	5	5	5	5	9			
40	5	5	5	5	5	9			
65	5	5	5	5	5	9			
85	5	5	5	5	5	7.5			
105	5	5	5	5					

High-output Setting Enabled

■ RCP6/RCP6S-TA4C

Lead 10

Orientation	Horizontal						Vertical		
	Acceleration (G)								
Speed (mm/s)	0.1	0.3	0.5	0.7	1	0.1	0.3	0.5	
0	8	8	8	8	6	2.5	2.5	2	
85	8	8	8	8	6	2.5	2.5	2	
175	8	8	8	8	6	2.5	2.5	2	
260	8	8	8	8	6	2.5	2.5	2	
350	8	8	8	6	6	2.5	2.5	2	
435	8	8	6	5		2.5	2		
525		8	5	4.5				2	
610		6	4.5	4				1.5	
700		4	3.5	2.5				0.5	
785			2	2					

Lead 5

Orientation	Horizontal						Vertical		
	Acceleration (G)								
Speed (mm/s)	0.1	0.3	0.5	0.7	1	0.1	0.3	0.5	
0	10	10	9	8	6	5	5	5	
40	10	10	9	8	6	5	5	5	
85	10	10	9	8	6	5	5	5	
130	10	9	9	8	6	5	5	5	
175	10	9	8	6	6	5	5	5	
215	10	9	8	6	5	5	5	5	
260	9	8	7	5	4.5	5	5	5	
305	9	8	6	5	4	4.5	4.5	4.5	
350	8	7	6	4	3.5	3.5	3	3	
390	7	6	4	3		2	2	2	

Lead 2.5

Orientation	Horizontal						Vertical		
	Acceleration (G)								
Speed (mm/s)	0.1	0.3	0.5	0.7	1	0.1	0.3	0.5	
0	10	10	9	8	6	10	9	8	
20	10	10	9	8	6	10	9	8	
40	10	10	9	8	6	10	9	8	
65	10	9	9	8	6	10	9	8	
85	10	9	8	6	6	10	9	7	
105	10	9	8	6	5	10	8	7	
130	9	8	7	5	4.5	10	8	6	
150	9	8	6	5	4	9	7	6	
175	8	7	6	4	3.5	8	7	5	
195	8	7	6	4	3	6	5	5	

■ RCP6/RCP6S-TA6C

Lead 12

Orientation	Horizontal						Vertical		
	Acceleration (G)								
Speed (mm/s)	0.1	0.3	0.5	0.7	1	0.1	0.3	0.5	
0	15	15	12	11	10	3	3	3	
80	15	15	12	11	10	3	3	3	
200	15	15	12	11	10	3	3	3	
320	15	15	12	11	10	3	3	3	
440	15	14	11	10	8	3	3	3	
500		13	10	8	6	3	3	3	
560		12	9	6	4		3	2.5	
680		10	7	4	2		1.5	1	
800			5	2	1				

Lead 6

Orientation	Horizontal						Vertical		
	Acceleration (G)								
Speed (mm/s)	0.1	0.3	0.5	0.7	1	0.1	0.3	0.5	
0	20	20	18	16	14	6	6	6	
40	20	20	18	16	14	6	6	6	
100	20	20	18	16	14	6	6	6	
160	20	20	18	16	14	6	6	6	
220	20	20	18	16	14	6	6	6	
250	20	20	18	16	14	6	6	5.5	
280	20	18	16	15	11	6	5.5	5	
340	20	16	14	12	9	6	4.5	4	
400	18	14	10	8	6	4.5	3.5	3	

Lead 3

Orientation	Horizontal						Vertical		
	Acceleration (G)								
Speed (mm/s)	0.1	0.3	0.5	0.7	1	0.1	0.3	0.5	
0	20	20	18	16	15	12	12	10	
20	20	20	18	16	15	12	12	10	
50	20	20	18	16	15	12	12	10	
80	20	20	18	16	15	12	12	10	
110	20	20	18	16	15	12	12	10	
125	20	20	18	16	15	12	12	10	
140	20	20	18	16	15	12	12	10	
170	20	18	16	14	12	12	10	9	
200	18	16	14	12	10	9	8	8	

■ RCP6/RCP6S-TA7C

Lead 16

Orientation	Horizontal						Vertical		
	Acceleration (G)								
Speed (mm/s)	0.1	0.3	0.5	0.7	1	0.1	0.3	0.5	
0	25	25	20	20	18	7	7	7	
140	25	25	20	20	18	7	7	7	
280	22	20	16	16	14	7	7	6	
420	20	16	14	12	8	6	5	4	
560	16	14	10	6	4	3	1.5	0.5	
700		8	3.5						

Lead 8

Orientation	Horizontal						Vertical		
	Acceleration (G)								
Speed (mm/s)	0.1	0.3	0.5	0.7	1	0.1	0.3	0.5	
0	30	30	28	26	24	16	16	14	
70	30	30	28	26	24	16	16	14	
140	30	28	24	22	20	16	14	10	
210	30	22	20	18	16	12	10	8	
280	20	18	16	12	10	9	8	6	
350	14	12	7			4			
420	8								

Lead 4

Orientation	Horizontal						Vertical		
	Acceleration (G)								
Speed (mm/s)	0.1	0.3	0.5	0.7	1	0.1	0.3	0.5	
0	30	30	28	26	24	24	24	24	
35	30	30	28	26	24	24	24	24	
70	30	28	24	22	20	24	22	20	
105	25	22	20	18	16	22	20	16	
140	20	18	16	12	10	16	14	10	
175	14	12	6			9	4		
210	7					4			

High-output Setting Disabled

■ RCP6/RCP6S-TA4C

Lead 10

Orientation	Horizontal						Vertical		
	Acceleration (G)								
Speed (mm/s)	0.1	0.3	0.5	0.7	1	0.1	0.3	0.5	
0	8		6			2.5			
85	8		6			2.5			
175	8		6			2.5			
260	8		6			2.25			
350	7		5			1.5			
435	5		3.5			1			
525			1.5						

Lead 5

Orientation	Horizontal						Vertical		
	Acceleration (G)								
Speed (mm/s)	0.1	0.3	0.5	0.7	1	0.1	0.3	0.5	
0	10		8			5			
40	10		8			5			
85	10		8			5			
130	9		8			5			
175	9		6			4.5			
215	9		6			4			
260	8		5			2.5			

Lead 2.5

Orientation	Horizontal						Vertical		
	Acceleration (G)								
Speed (mm/s)	0.1	0.3	0.5	0.7	1	0.1	0.3	0.5	
0	10		8			9			
20	10		8			9			
40	10		8			9			
65	9		8			9			
85	9		6			7.5			
105	9		6			6			
130	8		5			4			

■ RCP6/RCP6S-TA6C

Lead 12

Orientation	Horizontal						Vertical		
	Acceleration (G)								
Speed (mm/s)	0.1	0.3	0.5	0.7	1	0.1	0.3	0.5	
0	15		11			3			
80	15		11			3			
200	15		11			3			
320	15		10			2.5			
440	9		5			1			
500	6		3						
560	4		1.5						

Lead 6

Orientation	Horizontal						Vertical		
	Acceleration (G)								
Speed (mm/s)	0.1	0.3	0.5	0.7	1	0.1	0.3	0.5	
0	20		16			6			
40	20		16			6			
100	20		16			6			
160	20		16			6			
220	20		16			4			
250	17		12			3			
280	14		8			2			
340	5		3						

Lead 3

Orientation	Horizontal						Vertical		
	Acceleration (G)								
Speed (mm/s)	0.1	0.3	0.5	0.7	1	0.1	0.3	0.5	
0	20		16			12			
20	20		16			12			
50	20		16			12			
80	20		16			12			
110	20		16			9			
125	18		15			7			
140	15		14			5			
170	10		7						

■ RCP6/RCP6S-TA7C

Lead 16

Orientation	Horizontal						Vertical		
	Acceleration (G)								
Speed (mm/s)	0.1	0.3	0.5	0.7	1	0.1	0.3	0.5	
0	22		18			5			
140	22		18			5			
280	16		14			5			
420	10		4						
560	2								

Lead 8

Orientation	Horizontal						Vertical		
	Acceleration (G)								
Speed (mm/s)	0.1	0.3	0.5	0.7	1	0.1	0.3	0.5	
0	30		26			12			
70	30		26			12			
140	25		18			12			

Tables of Payload by Speed/Acceleration

RCP6 Series

Table Type Side-Mounted Motor Specification Single Block

High-output Setting Enabled

RCP6/RCP6S-TA4R

Lead 16

Orientation	Horizontal						Vertical		
	Acceleration (G)								
Speed (mm/s)	0.1	0.3	0.5	0.7	1	0.1	0.3	0.5	
0	3	3	3	3	3	1	1	1	
140	3	3	3	3	3	1	1	1	
280	3	3	3	3	3	1	1	1	
420	3	3	3	3	3	1	1	1	
560	3	3	3	3	3	1	1	1	
700		3	3	3					
840			3	2.5					
980				1.5					
1120									
1260									

Lead 10

Orientation	Horizontal						Vertical		
	Acceleration (G)								
Speed (mm/s)	0.1	0.3	0.5	0.7	1	0.1	0.3	0.5	
0	4	4	4	4	4	2.5	2.5	2	
85	4	4	4	4	4	2.5	2.5	2	
175	4	4	4	4	4	2.5	2.5	2	
260	4	4	4	4	4	2.5	2.5	2	
350	4	4	4	4	4	2.5	2.5	2	
435	4	4	4	4		2.5	2		
525		4	4	4			2		
610		4	4	4					
700		4	4	4					
785			4	2.5			1.5		
				2.5	2				

Lead 5

Orientation	Horizontal						Vertical		
	Acceleration (G)								
Speed (mm/s)	0.1	0.3	0.5	0.7	1	0.1	0.3	0.5	
0	5	5	5	5	5	5	5	5	
40	5	5	5	5	5	5	5	5	
85	5	5	5	5	5	5	5	5	
130	5	5	5	5	5	5	5	5	
175	5	5	5	5	5	5	5	5	
215	5	5	5	5	5	5	5	5	
260	5	5	5	5	4.5	5	5	5	
305	5	5	5	5	4	4.5	4.5	4.5	
350	5	5	5	4	3.5	4	2	2	
390		5	5	4	3		1.5	1	

Lead 2.5

Orientation	Horizontal						Vertical		
	Acceleration (G)								
Speed (mm/s)	0.1	0.3	0.5	0.7	1	0.1	0.3	0.5	
0	5	5	5	5	5	10	9	8	
20	5	5	5	5	5	10	9	8	
40	5	5	5	5	5	10	9	8	
65	5	5	5	5	5	10	9	8	
85	5	5	5	5	5	10	9	7	
105	5	5	5	5	5	10	8	7	
130	5	5	5	5	4.5	10	8	6	
150	5	5	5	5	4	9	7	6	
175	5	5	5	4	3.5	7.5	7	4.5	
195	5	5	5	4	3	5	4	4	

RCP6/RCP6S-TA6R

Lead 20

Orientation	Horizontal						Vertical		
	Acceleration (G)								
Speed (mm/s)	0.1	0.3	0.5	0.7	1	0.1	0.3	0.5	
0	5	5	5	5	5	1	1	1	
160	5	5	5	5	5	1	1	1	
320	5	5	5	5	5	1	1	1	
480	5	5	5	5	5	1	1	1	
640	5	5	5	5	5	1	1	1	
800		5	4.5	4					
960			3.5	2					
1120				1.5					

Lead 12

Orientation	Horizontal						Vertical		
	Acceleration (G)								
Speed (mm/s)	0.1	0.3	0.5	0.7	1	0.1	0.3	0.5	
0	8	8	8	7	6	3	3	3	
80	8	8	8	7	6	3	3	3	
200	8	8	8	7	6	3	3	3	
320	8	8	8	7	6	3	3	3	
440	8	8	8	7	6	3	3	3	
500		8	8	7	6		3	3	
560		8	8	6	4		3	2.5	
680		8	7	4	2.5		2	1.5	
800			5	2	1				

Lead 6

Orientation	Horizontal						Vertical		
	Acceleration (G)								
Speed (mm/s)	0.1	0.3	0.5	0.7	1	0.1	0.3	0.5	
0	10	10	9	8	7	6	6	6	
40	10	10	9	8	7	6	6	6	
100	10	10	9	8	7	6	6	6	
160	10	10	9	8	7	6	6	6	
220	10	10	9	8	7	6	6	6	
250	10	10	9	8	7	6	6	5.5	
280	10	10	9	8	7	6	5.5	5	
340	10	10	9	8	7	6	4.5	4	
400	10	9	8	7	6	4.5	3.5	3	

Lead 3

Orientation	Horizontal						Vertical		
	Acceleration (G)								
Speed (mm/s)	0.1	0.3	0.5	0.7	1	0.1	0.3	0.5	
0	10	10	10	8	7	12	12	10	
20	10	10	10	8	7	12	12	10	
50	10	10	10	8	7	12	12	10	
80	10	10	10	8	7	12	12	10	
110	10	10	10	8	7	12	12	10	
125	10	10	10	8	7	12	12	10	
140	10	10	10	8	7	12	12	10	
170	10	10	8	7	6	5	5	5	
200	10	8	7	6	4	4	4	4	

RCP6/RCP6S-TA7R

Lead 24

Orientation	Horizontal						Vertical		
	Acceleration (G)								
Speed (mm/s)	0.1	0.3	0.5	0.7	1	0.1	0.3	0.5	
0	10	10	10	8	8	3	3	3	
200	10	10	10	8	8	3	3	3	
420	10	10	10	8	8	3	3	3	
640	10	10	7	6		3	2.5		
860		7	5	4	2		1	0.5	
1080			2	0.5					

Lead 16

Orientation	Horizontal						Vertical		
	Acceleration (G)								
Speed (mm/s)	0.1	0.3	0.5	0.7	1	0.1	0.3	0.5	
0	12	12	12	10	10	7	7	7	
140	12	12	12	10	10	7	7	7	
280	12	12	12	10	10	7	7	6	
420	12	12	12	10	8	6	5	4	
560		12	10	7	5		3	1.5	
700		9	4	1					

Lead 8

Orientation	Horizontal						Vertical		
	Acceleration (G)								
Speed (mm/s)	0.1	0.3	0.5	0.7	1	0.1	0.3	0.5	
0	15	15	15	15	15	16	14	12	
70	15	15	15	15	15	16	14	12	
140	15	15	15	15	12	16	14	10	
210	15	15	15	12	10	12	10	8	
280	15	15	12	10	8	9	7	6	
350	12	10	8			4			
420	8								

Lead 4

Orientation	Horizontal						Vertical		
	Acceleration (G)								
Speed (mm/s)	0.1	0.3	0.5	0.7	1	0.1	0.3	0.5	
0	15	15	15	15	15	20	20	20	
35	15	15	15	15	15	20	20	20	
70	15	15	15	15	15	20	18	14	
105	15	15	15	15	12	18	16	10	
140	15	15	15	12	10	16	12	6	
175	15	10	4			7	4		
210	4					2			

High-output Setting Disabled

RCP6/RCP6S-TA4R

Lead 16

Orientation	Horizontal						Vertical		
	Acceleration (G)								
Speed (mm/s)	0.1	0.3	0.5	0.7	1	0.1	0.3	0.5	
0	3	3	3	3	3	1	1	1	
140	3	3	3	3	3	1	1	1	
280	3	3	3	3	3	1	1	1	
420	3	3	3	3	3	1	1	1	
560	2.5	2				0.75			
700			1.5						
840			1						

Lead 10

Orientation	Horizontal						Vertical		
	Acceleration (G)								
Speed (mm/s)	0.1	0.3	0.5	0.7	1	0.1	0.3	0.5	
0	4	4	4	4	4	2.5			
85	4	4	4	4	4	2.5			
175	4	4	4	4	4	2.5			
260	4	4	4	4	4	2.5			
350	4	4	4	4	4	1.5			
435	4	3.5				1			
525		4	2						

Lead 5

Orientation	Horizontal						Vertical		
	Acceleration (G)								
Speed (mm/s)	0.1	0.3	0.5	0.7	1	0.1	0.3	0.5	
0	5	5	5	5	5	5			
40	5	5	5	5	5	5			
85	5	5	5	5	5	5			
130	5	5	5	5	5	5			
175	5	5	5	5	5	4.5			
215	5	5	5	5	5	4			
260	5	5	5	5	5	2.5			

Lead 2.5

Orientation	Horizontal						Vertical		
	Acceleration (G)								
Speed (mm/s)	0.1	0.3	0.5	0.7	1	0.1	0.3	0.5	
0	5	5	5	5	5	9			
20	5	5	5	5	5	9			
40	5	5	5	5	5	9			
65	5	5	5	5	5	9			
85	5	5	5	5	5	7.5			
105	5	5	5	5	5				

High-output Setting Enabled

■ RCP6/RCP6S-TA4R

Lead 10

Orientation Speed (mm/s)	Horizontal						Vertical		
	Acceleration (G)								
	0.1	0.3	0.5	0.7	1	0.1	0.3	0.5	
0	8	8	8	8	6	2.5	2.5	2	
85	8	8	8	8	6	2.5	2.5	2	
175	8	8	8	8	6	2.5	2.5	2	
260	8	8	8	8	6	2.5	2.5	2	
350	8	8	8	6	6	2.5	2.5	2	
435	8	8	6	5		2.5	2		
525		8	5	4.5				1.5	
610			5	4	3.5				
700			3.5	2.5	2				

Lead 5

Orientation Speed (mm/s)	Horizontal						Vertical		
	Acceleration (G)								
	0.1	0.3	0.5	0.7	1	0.1	0.3	0.5	
0	10	10	9	8	6	5	5	5	
40	10	10	9	8	6	5	5	5	
85	10	10	9	8	6	5	5	5	
130	10	9	9	8	6	5	5	5	
175	10	9	8	6	6	5	5	5	
215	10	9	8	6	5	5	5	5	
260	9	8	7	5	4.5	5	5	5	
305	9	8	6	5	4	4	4	4	
350	8	7	6	4	3.5	3.5	3	3	
390		7	6	3.5	3		2	2	

Lead 2.5

Orientation Speed (mm/s)	Horizontal						Vertical		
	Acceleration (G)								
	0.1	0.3	0.5	0.7	1	0.1	0.3	0.5	
0	10	10	9	8	6	10	9	8	
20	10	10	9	8	6	10	9	8	
40	10	10	9	8	6	10	9	8	
65	10	9	9	8	6	10	9	8	
85	10	9	8	6	6	10	9	7	
105	10	9	8	6	5	10	8	7	
130	9	8	7	5	4.5	10	8	6	
150	9	8	6	5	4	9	7	6	
175	8	7	6	4	3.5	5	5	4.5	
195	8	7	6	4	3	4.5	4	4	

■ RCP6/RCP6S-TA6R

Lead 12

Orientation Speed (mm/s)	Horizontal						Vertical		
	Acceleration (G)								
	0.1	0.3	0.5	0.7	1	0.1	0.3	0.5	
0	15	15	12	11	10	3	3	3	
80	15	15	12	11	10	3	3	3	
200	15	15	12	11	10	3	3	3	
320	15	15	12	11	10	3	3	3	
440	15	14	11	10	8	3	3	3	
500		13	10	8	6		3	3	
560		12	9	6	3		3	2.5	
680		10	6	3	1.5		1.5	1	
800			4	1					

Lead 6

Orientation Speed (mm/s)	Horizontal						Vertical		
	Acceleration (G)								
	0.1	0.3	0.5	0.7	1	0.1	0.3	0.5	
0	20	20	18	16	14	6	6	6	
40	20	20	18	16	14	6	6	6	
100	20	20	18	16	14	6	6	6	
160	20	20	18	16	14	6	6	6	
220	20	20	18	16	14	6	6	6	
250	20	20	18	16	14	6	6	5.5	
280	20	18	16	15	11	6	5.5	5	
340	20	16	14	12	9	6	4.5	4	
400	18	14	10	8	6	4	2	1.5	

Lead 3

Orientation Speed (mm/s)	Horizontal						Vertical		
	Acceleration (G)								
	0.1	0.3	0.5	0.7	1	0.1	0.3	0.5	
0	20	20	18	16	15	12	12	10	
20	20	20	18	16	15	12	12	10	
50	20	20	18	16	15	12	12	10	
80	20	20	18	16	15	12	12	10	
110	20	20	18	16	15	12	12	10	
125	20	20	18	16	15	12	12	10	
140	20	20	18	16	15	12	12	10	
170	20	18	16	14	12	12	9	8	
200	18	16	14	12	10	8	7	7	

■ RCP6/RCP6S-TA7R

Lead 16

Orientation Speed (mm/s)	Horizontal						Vertical		
	Acceleration (G)								
	0.1	0.3	0.5	0.7	1	0.1	0.3	0.5	
0	25	25	20	20	18	7	7	7	
140	25	25	20	20	18	7	7	7	
280	22	20	16	16	14	7	7	6	
420	20	16	14	12	8	5	4	3	
560	16	14	10	6	3	3	1		
700		8	3						

Lead 8

Orientation Speed (mm/s)	Horizontal						Vertical		
	Acceleration (G)								
	0.1	0.3	0.5	0.7	1	0.1	0.3	0.5	
0	30	30	28	26	24	16	16	14	
70	30	30	28	26	24	16	16	14	
140	30	28	24	22	20	16	14	10	
210	30	22	20	18	16	12	10	8	
280	20	18	16	12	10	9	5.5	4.5	
350	14	12	6			3			
420	6								

Lead 4

Orientation Speed (mm/s)	Horizontal						Vertical		
	Acceleration (G)								
	0.1	0.3	0.5	0.7	1	0.1	0.3	0.5	
0	30	30	28	26	24	24	24	24	
35	30	30	28	26	24	24	24	24	
70	30	28	24	22	20	24	22	20	
105	25	22	20	18	16	22	20	16	
140	20	18	16	12	10	16	14	10	
175	14	10	5			8	3		
210	6					3			

High-output Setting Disabled

■ RCP6/RCP6S-TA4R

Lead 10

Orientation Speed (mm/s)	Horizontal						Vertical		
	Acceleration (G)								
	0.1	0.3	0.5	0.7	1	0.1	0.3	0.5	
0	8	8	6			2.5			
85	8	8	6			2.5			
175	8	8	6			2.5			
260	8	8	6			2.5			
350	7	5				1.5			
435	5		3.5			1			
525			1.5						

Lead 5

Orientation Speed (mm/s)	Horizontal						Vertical		
	Acceleration (G)								
	0.1	0.3	0.5	0.7	1	0.1	0.3	0.5	
0	10		8			5			
40	10		8			5			
85	10		8			5			
130	9		8			5			
175	9		6			4.5			
215	9		6			4			
260	8		5			2.5			

Lead 2.5

Orientation Speed (mm/s)	Horizontal						Vertical		
	Acceleration (G)								
	0.1	0.3	0.5	0.7	1	0.1	0.3	0.5	
0	10		8			9			
20	10		8			9			
40	10		8			9			
65	9		8			9			
85	9		6			7.5			
105	9		6			6			
130	8		5			4			

■ RCP6/RCP6S-TA6R

Lead 12

Orientation Speed (mm/s)	Horizontal						Vertical		
	Acceleration (G)								
	0.1	0.3	0.5	0.7	1	0.1	0.3	0.5	
0	15		11			3			
80	15		11			3			
200	15		11			3			
320	15		10			2.5			
440	9		5			1			
500	6		3						
560	4		1.5						

Lead 6

Orientation Speed (mm/s)	Horizontal						Vertical		
	Acceleration (G)								
	0.1	0.3	0.5	0.7	1	0.1	0.3	0.5	
0	20		16			6			
40	20		16			6			
100	20		16			6			
160	20		16			6			
220	20		16			4			
250	17		12			3			
280	14		8			2			
340	5		3						

Lead 3

Orientation Speed (mm/s)	Horizontal						Vertical		
	Acceleration (G)								
	0.1	0.3	0.5	0.7	1	0.1	0.3	0.5	
0	20		16			12			
20	20		16			12			
50	20		16			12			
80	20		16			12			
110	20		16			9			
125	18		15			7			
140	15		14			5			
170	10		7						

■ RCP6/RCP6S-TA7R

Lead 16

Orientation Speed (mm/s)	Horizontal						Vertical		
	Acceleration (G)								
	0.1	0.3	0.5	0.7	1	0.1	0.3	0.5	
0	22		18			5			
140	22		18			5			
280	16		14			5			
420	10		4						
560	2								

Lead 8

Orientation Speed (mm/s)	Horizontal						Vertical		
	Acceleration (G)								
	0.1	0.3	0.5	0.7	1	0.1	0.3	0.5	
0	30		26			12			
70	30		26			12			
140	25		18			12			
210	18		10			3.5			
280	4								

Lead 4

Orientation Speed (mm/s)

Tables of Payload by Speed/Acceleration

RCP6W Series

Rod Type Motor Coupling Specification

High-output Setting Enabled

■ RCP6W/RCP6SW-RA4C

<When ambient temperature exceeds 5°C>

Lead 10

Orientation	Horizontal				Vertical			
	Acceleration (G)							
Speed (mm/s)	0.1	0.3	0.5	0.7	1	0.1	0.3	0.5
0	11	11	9	9	7	2	2	2
85	11	11	9	9	7	2	2	2
175	11	11	8	7	5	2	2	2
260	11	11	7	4	2	2	2	2
350	11	11	7	3	1	2	2	2
435	11	10	6	3	1	1.5	1	1
525		4	1					

Lead 5

Orientation	Horizontal				Vertical			
	Acceleration (G)							
Speed (mm/s)	0.1	0.3	0.5	0.7	1	0.1	0.3	0.5
0	23	23	21	18	18	4	4	4
40	23	23	21	18	18	4	4	4
85	23	23	21	18	18	4	4	4
130	23	23	21	18	18	4	4	4
175	23	23	21	16	14	4	4	4
215	23	23	21	14	12	4	4	4
260	23	22	18	12	8	4	4	4
305	22	14	8	6	4	3	3	3
350	19	5	1			2	1	1

Lead 2.5

Orientation	Horizontal				Vertical			
	Acceleration (G)							
Speed (mm/s)	0.1	0.3	0.5	0.7	1	0.1	0.3	0.5
0	40	40	40	35	30	10	10	10
20	40	40	40	35	30	10	10	10
40	40	40	40	35	30	10	10	10
65	40	40	40	30	30	10	10	10
85	40	40	35	30	30	10	10	10
105	40	40	35	30	30	10	6	6
130	40	40	35	30	30	4	4	4
150	40	35	35	29	24	2	2	2
175	33	24	22	19	12			

<When ambient temperature is 5°C or below>

Lead 10

Orientation	Horizontal				Vertical			
	Acceleration (G)							
Speed (mm/s)	0.1	0.3	0.5	0.7	1	0.1	0.3	0.5
0	11	11	9	9	7	2	2	2
85	11	11	9	9	7	2	2	2
175	11	11	8	7	5	2	2	2
260	11	11	7	4	2	2	2	2
350	11	11	7	3	1	2	2	2
435	11	10	6	3	1	1.5	1	1

Lead 5

Orientation	Horizontal				Vertical			
	Acceleration (G)							
Speed (mm/s)	0.1	0.3	0.5	0.7	1	0.1	0.3	0.5
0	23	23	21	18	18	4	4	4
40	23	23	21	18	18	4	4	4
85	23	23	21	18	18	4	4	4
130	23	23	21	18	18	4	4	4
175	23	23	21	16	14	4	4	4
215	23	23	21	14	12	4	4	4
260	23	22	18	12	8	4	4	4

Lead 2.5

Orientation	Horizontal				Vertical			
	Acceleration (G)							
Speed (mm/s)	0.1	0.3	0.5	0.7	1	0.1	0.3	0.5
0	40	40	40	35	30	10	10	10
20	40	40	40	35	30	10	10	10
40	40	40	40	35	30	10	10	10
65	40	40	40	30	30	10	10	10
85	40	40	35	30	30	10	10	10
105	40	40	35	30	30	10	6	6
130	40	40	35	30	30	4	4	4

■ RCP6W/RCP6SW-RA6C

<When ambient temperature exceeds 5°C>

Lead 12

Orientation	Horizontal				Vertical			
	Acceleration (G)							
Speed (mm/s)	0.1	0.3	0.5	0.7	1	0.1	0.3	0.5
0	25	25	18	16	12	4	4	4
105	25	25	18	16	12	4	4	4
210	25	25	17	14	10	4	4	4
315	25	25	15	10	6	4	4	4
420	20	20	10	10	6	4	4	4
525	15	15	8	6	4.5	2	1	1
630		8	3	2	1			

Lead 6

Orientation	Horizontal				Vertical			
	Acceleration (G)							
Speed (mm/s)	0.1	0.3	0.5	0.7	1	0.1	0.3	0.5
0	40	40	35	30	25	10	10	10
55	40	40	35	30	25	10	10	10
105	40	40	35	30	25	10	10	10
160	40	40	35	25	25	10	10	10
210	40	40	30	25	20	9	9	9
265	40	40	27.5	22.5	18	8	8	7
315	40	35	21	20	14	4	4	4
370	38	16	10	8	6	2	2	2
420	28	7	6					

Lead 3

Orientation	Horizontal				Vertical			
	Acceleration (G)							
Speed (mm/s)	0.1	0.3	0.5	0.7	1	0.1	0.3	0.5
0	60	60	50	45	40	20	20	20
20	60	60	50	45	40	20	20	20
45	60	60	50	45	40	20	20	20
70	60	60	50	45	40	20	20	20
105	60	60	50	45	40	20	20	20
130	60	60	50	40	30	18	14	10
155	60	50	40	30	25	14	10	6
180	60	40	35	25	20	9	6	5
210	60	26	22	20	14	6	4	4

<When ambient temperature is 5°C or below>

Lead 12

Orientation	Horizontal				Vertical			
	Acceleration (G)							
Speed (mm/s)	0.1	0.3	0.5	0.7	1	0.1	0.3	0.5
0	25	25	18	16	12	4	4	4
105	25	25	18	16	12	4	4	4
210	25	25	17	14	10	4	4	4
315	25	25	15	10	6	4	4	4
420	20	20	10	10	6	4	4	4
525	15	15	8	6	4.5	2	1	1

Lead 6

Orientation	Horizontal				Vertical			
	Acceleration (G)							
Speed (mm/s)	0.1	0.3	0.5	0.7	1	0.1	0.3	0.5
0	40	40	35	30	25	10	10	10
55	40	40	35	30	25	10	10	10
105	40	40	35	30	25	10	10	10
160	40	40	35	25	25	10	10	10
210	40	40	30	25	20	9	9	9
265	40	40	27.5	22.5	18	8	8	7
315	40	35	21	20	14	4	4	4

Lead 3

Orientation	Horizontal				Vertical			
	Acceleration (G)							
Speed (mm/s)	0.1	0.3	0.5	0.7	1	0.1	0.3	0.5
0	60	60	50	45	40	20	20	20
20	60	60	50	45	40	20	20	20
45	60	60	50	45	40	20	20	20
70	60	60	50	45	40	20	20	20
105	60	60	50	45	40	20	20	20

High-output Setting Enabled

■ RCP6W/RCP6SW-RA7C

<When ambient temperature exceeds 5°C>

Lead 16

Orientation	Horizontal				Vertical			
	Acceleration (G)							
Speed (mm/s)	0.1	0.3	0.5	0.7	1	0.1	0.3	0.5
0	50	50	40	35	30	8	8	8
140	50	50	40	35	30	8	8	8
280	50	45	32	22	17	6	6	5
420	50	18	9	6	5	1.5	1	0.5

Lead 8

Orientation	Horizontal				Vertical			
	Acceleration (G)							
Speed (mm/s)	0.1	0.3	0.5	0.7	1	0.1	0.3	0.5
0	60	60	50	45	40	18	18	18
70	60	60	50	45	40	18	18	18
140	60	60	50	45	40	16	16	12
210	60	60	40	30	20	8	7	6
280	60	20	9	6	3	3	2	1
350	20							

Lead 4

Orientation	Horizontal				Vertical			
	Acceleration (G)							
Speed (mm/s)	0.1	0.3	0.5	0.7	1	0.1	0.3	0.5
0	80	80	70	65	60	28	28	28
35	80	80	70	65	60	28	28	28
70	80	80	70	65	60	28	28	28
105	80	80	60	50	40	21	20	18
140	67	47	10	6	6	8	6	6

<When ambient temperature is 5°C or below>

Lead 16

Orientation	Horizontal				Vertical			
	Acceleration (G)							
Speed (mm/s)	0.1	0.3	0.5	0.7	1	0.1	0.3	0.5
0	50	50	40	35	30	8	8	8
140	50	50	40	35	30	8	8	8
280	50	45	32	22	17	6	6	5

Lead 8

Orientation	Horizontal				Vertical			
	Acceleration (G)							
Speed (mm/s)	0.1	0.3	0.5	0.7	1	0.1	0.3	0.5
0	60	60	50	45	40	18	18	18
70	60	60	50	45	40	18	18	18
140	60	60	50	45	40	8	8	8

Lead 4

Orientation	Horizontal				Vertical			
	Acceleration (G)							
Speed (mm/s)	0.1	0.3	0.5	0.7	1	0.1	0.3	0.5
0	80	80	70	65	60	28	28	28
35	80	80	70	65	60	28	28	28
60	80	80	70	65	60	28	28	28
70	80	80	70	65	60	21	21	21
105	80	80	60	50	40	8	8	8

■ RCP6W/RCP6SW-RA8C

<When ambient temperature exceeds 5°C>

Lead 20

Orientation	Horizontal	Orientation	Vertical
	Acceleration (G)		Acceleration (G)
Speed (mm/s)	0.2	Speed (mm/s)	0.2
0	30	0	3
300	30	300	3
350	14	330	1

Lead 10

Orientation	Horizontal	Orientation	Vertical
	Acceleration (G)		Acceleration (G)
Speed (mm/s)	0.2	Speed (mm/s)	0.2
0	60	0	35
160	60	80	35
170	40	90	34
180	25	100	28
190	15	110	23
200	12	120	18
		130	15
		140	12
		150	10
		160	8
		170	6
		180	4
		190	3
		200	2

Lead 5

Orientation	Horizontal	Orientation	Vertical
	Acceleration (G)		Acceleration (G)
Speed (mm/s)	0.1	Speed (mm/s)	0.1
0	100	0	70
80	100	45	70
90	100	60	45
100	75	70	35
		80	25
		90	14
		100	9

<When ambient temperature is 5°C or below>

Lead 20

Orientation	Horizontal	Orientation	Vertical
	Acceleration (G)		Acceleration (G)
Speed (mm/s)	0.2	Speed (mm/s)	0.2
0	30	0	3
300	30	300	3

Lead 10

Orientation	Horizontal	Orientation	Vertical
	Acceleration (G)		Acceleration (G)
Speed (mm/s)	0.2	Speed (mm/s)	0.2
0	60	0	35
160	60	80	35
170	40	90	34
		100	28
		110	23
		120	18
		130	15
		140	12
		150	10
		160	8
		170	6

Lead 5

Orientation	Horizontal	Orientation	Vertical
	Acceleration (G)		Acceleration (G)
Speed (mm/s)	0.1	Speed (mm/s)	0.1
0	100	0	70
80	100	45	70
		60	35
		70	25
		80	9

Tables of Payload by Speed/Acceleration

RCP6W Series

Rod Type Side-Mounted Motor Specification

High-output Setting Enabled

■ RCP6W/RCP6SW-RA4R

<When ambient temperature exceeds 5°C>

Lead 10

Orientation	Horizontal					Vertical		
	Acceleration (G)							
Speed (mm/s)	0.1	0.3	0.5	0.7	1	0.1	0.3	0.5
0	11	11	9	9	7	2	2	2
85	11	11	9	9	7	2	2	2
175	11	11	8	7	5	2	2	2
260	11	11	7	4	2	2	2	2
350	11	11	7	3	1	2	2	2
435	11	10	6	3	1	1.5	1	1
525		4	1					

Lead 5

Orientation	Horizontal					Vertical		
	Acceleration (G)							
Speed (mm/s)	0.1	0.3	0.5	0.7	1	0.1	0.3	0.5
0	23	23	21	18	18	4	4	4
40	23	23	21	18	18	4	4	4
85	23	23	21	18	18	4	4	4
130	23	23	21	18	18	4	4	4
175	23	23	21	16	14	4	4	4
215	23	23	21	14	12	4	4	4
260	23	22	18	12	8	4	4	4
305	22	14	8	6	4	3	3	3
350	19	5	1			2	1	1

Lead 2.5

Orientation	Horizontal					Vertical		
	Acceleration (G)							
Speed (mm/s)	0.1	0.3	0.5	0.7	1	0.1	0.3	0.5
0	40	40	40	35	30	10	10	10
20	40	40	40	35	30	10	10	10
40	40	40	40	35	30	10	10	10
65	40	40	40	30	30	10	10	10
85	40	40	35	30	30	10	10	10
105	40	40	35	30	30	10	6	6
130	40	40	35	30	30	4	4	4
150	40	35	35	29	24	2	2	2
175	33	24	22	19	12			

<When ambient temperature is 5°C or below>

Lead 10

Orientation	Horizontal					Vertical		
	Acceleration (G)							
Speed (mm/s)	0.1	0.3	0.5	0.7	1	0.1	0.3	0.5
0	11	11	9	9	7	2	2	2
85	11	11	9	9	7	2	2	2
175	11	11	8	7	5	2	2	2
260	11	11	7	4	2	2	2	2
350	11	11	7	3	1	2	2	2
435	11	10	6	3	1	1.5	1	1

Lead 5

Orientation	Horizontal					Vertical		
	Acceleration (G)							
Speed (mm/s)	0.1	0.3	0.5	0.7	1	0.1	0.3	0.5
0	23	23	21	18	18	4	4	4
40	23	23	21	18	18	4	4	4
85	23	23	21	18	18	4	4	4
130	23	23	21	18	18	4	4	4
175	23	23	21	16	14	4	4	4
215	23	23	21	14	12	4	4	4
260	23	22	18	12	8	4	4	4

Lead 2.5

Orientation	Horizontal					Vertical		
	Acceleration (G)							
Speed (mm/s)	0.1	0.3	0.5	0.7	1	0.1	0.3	0.5
0	40	40	40	35	30	10	10	10
20	40	40	40	35	30	10	10	10
40	40	40	40	35	30	10	10	10
65	40	40	40	30	30	10	10	10
85	40	40	35	30	30	10	10	10
105	40	40	35	30	30	10	6	6
130	40	40	35	30	30	4	4	4

■ RCP6W/RCP6SW-RA6R

<When ambient temperature exceeds 5°C>

Lead 12

Orientation	Horizontal					Vertical		
	Acceleration (G)							
Speed (mm/s)	0.1	0.3	0.5	0.7	1	0.1	0.3	0.5
0	25	25	18	16	12	4	4	4
105	25	25	18	16	12	4	4	4
210	25	25	17	14	10	4	4	4
315	25	25	15	10	6	4	4	4
420	20	20	10	10	6	4	4	4
525	15	15	8	6	4.5	2	1	1
630		8	3	2	1			

Lead 6

Orientation	Horizontal					Vertical		
	Acceleration (G)							
Speed (mm/s)	0.1	0.3	0.5	0.7	1	0.1	0.3	0.5
0	40	40	35	30	25	10	10	10
55	40	40	35	30	25	10	10	10
105	40	40	35	30	25	10	10	10
160	40	40	35	25	25	10	10	10
210	40	40	30	25	20	9	9	9
265	40	40	27.5	22.5	18	8	8	7
315	40	35	21	20	14	4	4	4
370	38	16	10	8	6	2	2	2
420	28	7	6					

Lead 3

Orientation	Horizontal					Vertical		
	Acceleration (G)							
Speed (mm/s)	0.1	0.3	0.5	0.7	1	0.1	0.3	0.5
0	60	60	50	45	40	20	20	20
20	60	60	50	45	40	20	20	20
45	60	60	50	45	40	20	20	20
70	60	60	50	45	40	20	20	20
105	60	60	50	45	40	20	20	20
130	60	60	50	40	30	18	14	10
155	60	50	40	30	25	14	10	6
180	60	40	35	25	20	9	6	5
210	60	26	22	20	14	6	4	4

<When ambient temperature is 5°C or below>

Lead 12

Orientation	Horizontal					Vertical		
	Acceleration (G)							
Speed (mm/s)	0.1	0.3	0.5	0.7	1	0.1	0.3	0.5
0	25	25	18	16	12	4	4	4
105	25	25	18	16	12	4	4	4
210	25	25	17	14	10	4	4	4
315	25	25	15	10	6	4	4	4
420	20	20	10	10	6	4	4	4
525	15	15	8	6	4.5	2	1	1

Lead 6

Orientation	Horizontal					Vertical		
	Acceleration (G)							
Speed (mm/s)	0.1	0.3	0.5	0.7	1	0.1	0.3	0.5
0	40	40	35	30	25	10	10	10
55	40	40	35	30	25	10	10	10
105	40	40	35	30	25	10	10	10
160	40	40	35	25	25	10	10	10
210	40	40	30	25	20	9	9	9
265	40	40	27.5	22.5	18	8	8	7
315	40	35	21	20	14	4	4	4

Lead 3

Orientation	Horizontal					Vertical		
	Acceleration (G)							
Speed (mm/s)	0.1	0.3	0.5	0.7	1	0.1	0.3	0.5
0	60	60	50	45	40	20	20	20
20	60	60	50	45	40	20	20	20
45	60	60	50	45	40	20	20	20
70	60	60	50	45	40	20	20	20
105	60	60	50	45	40	20	20	20

High-output Setting Enabled

■ RCP6W/RCP6SW-RA7R

<When ambient temperature exceeds 5°C>

Lead 16

Orientation	Horizontal				Vertical			
	Acceleration (G)							
Speed (mm/s)	0.1	0.3	0.5	0.7	1	0.1	0.3	0.5
0	50	50	40	35	30	8	8	8
140	50	50	40	35	30	8	8	8
280	50	45	32	22	17	6	6	5
420	50	18	9	6	5	1.5	1	0.5

Lead 8

Orientation	Horizontal				Vertical			
	Acceleration (G)							
Speed (mm/s)	0.1	0.3	0.5	0.7	1	0.1	0.3	0.5
0	60	60	50	45	40	18	18	18
70	60	60	50	45	40	18	18	18
140	60	60	50	45	40	16	16	12
210	60	60	40	30	20	8	7	6
280	60	20	9	6	3	3	2	1
350	20							

Lead 4

Orientation	Horizontal				Vertical			
	Acceleration (G)							
Speed (mm/s)	0.1	0.3	0.5	0.7	1	0.1	0.3	0.5
0	80	80	70	65	60	28	28	28
35	80	80	70	65	60	28	28	28
70	80	80	70	65	60	28	28	28
105	80	80	60	50	40	21	20	18
140	67	47	10	6	6	8	6	6

<When ambient temperature is 5°C or below>

Lead 16

Orientation	Horizontal				Vertical			
	Acceleration (G)							
Speed (mm/s)	0.1	0.3	0.5	0.7	1	0.1	0.3	0.5
0	50	50	40	35	30	8	8	8
140	50	50	40	35	30	8	8	8
280	50	45	32	22	17	6	6	5

Lead 8

Orientation	Horizontal				Vertical			
	Acceleration (G)							
Speed (mm/s)	0.1	0.3	0.5	0.7	1	0.1	0.3	0.5
0	60	60	50	45	40	18	18	18
70	60	60	50	45	40	18	18	18
140	60	60	50	45	40	8	8	8

Lead 4

Orientation	Horizontal				Vertical			
	Acceleration (G)							
Speed (mm/s)	0.1	0.3	0.5	0.7	1	0.1	0.3	0.5
0	80	80	70	65	60	28	28	28
35	80	80	70	65	60	28	28	28
60	80	80	70	65	60	28	28	28
70	80	80	70	65	60	21	21	21
105	80	80	60	50	40	8	8	8

■ RCP6W/RCP6SW-RA8R

<When ambient temperature exceeds 5°C>

Lead 20

Orientation	Horizontal	Orientation	Vertical
	Acceleration (G)		Acceleration (G)
Speed (mm/s)	0.2	Speed (mm/s)	0.2
0	30	0	3
300	30	300	3
350	14	330	1

Lead 10

Orientation	Horizontal	Orientation	Vertical
	Acceleration (G)		Acceleration (G)
Speed (mm/s)	0.2	Speed (mm/s)	0.2
0	60	0	35
160	60	80	35
170	40	90	34
180	25	100	28
190	15	110	23
200	12	120	18
		130	15
		140	12
		150	10
		160	8
		170	6
		180	4
		190	3
		200	2

Lead 5

Orientation	Horizontal	Orientation	Vertical
	Acceleration (G)		Acceleration (G)
Speed (mm/s)	0.1	Speed (mm/s)	0.1
0	100	0	70
80	100	45	70
90	100	60	45
100	75	70	35
		80	25
		90	14
		100	9

<When ambient temperature is 5°C or below>

Lead 20

Orientation	Horizontal	Orientation	Vertical
	Acceleration (G)		Acceleration (G)
Speed (mm/s)	0.2	Speed (mm/s)	0.2
0	30	0	3
300	30	300	3

Lead 10

Orientation	Horizontal	Orientation	Vertical
	Acceleration (G)		Acceleration (G)
Speed (mm/s)	0.2	Speed (mm/s)	0.2
0	60	0	35
160	60	80	35
170	40	90	34
		100	28
		110	23
		120	18
		130	15
		140	12
		150	10
		160	8
		170	6

Lead 5

Orientation	Horizontal	Orientation	Vertical
	Acceleration (G)		Acceleration (G)
Speed (mm/s)	0.1	Speed (mm/s)	0.1
0	100	0	70
80	100	45	70
		60	35
		70	25
		80	9

Tables of Payload by Speed/Acceleration

RCP6W Series

Rod Type Motor Coupling Specification

High-output Setting Enabled

■ RCP6W/RCP6SW-RR4C

<When ambient temperature exceeds 5°C>

Lead 10

Orientation	Horizontal					Vertical		
	Acceleration (G)							
Speed (mm/s)	0.1	0.3	0.5	0.7	1	0.1	0.3	0.5
0	11	11	9	9	7	2	2	2
85	11	11	9	9	7	2	2	2
175	11	11	8	7	5	2	2	2
260	11	11	7	4	2	2	2	2
350	11	11	7	3	1	2	2	2
435	11	10	6	3	1	1.5	1	1
525		4	1					

Lead 5

Orientation	Horizontal					Vertical		
	Acceleration (G)							
Speed (mm/s)	0.1	0.3	0.5	0.7	1	0.1	0.3	0.5
0	23	23	21	18	18	4	4	4
40	23	23	21	18	18	4	4	4
85	23	23	21	18	18	4	4	4
130	23	23	21	18	18	4	4	4
175	23	23	21	16	14	4	4	4
215	23	23	21	14	12	4	4	4
260	23	22	18	12	8	4	4	4
305	22	14	8	6	4	3	3	3
350	19	5	1			2	1	1

Lead 2.5

Orientation	Horizontal					Vertical		
	Acceleration (G)							
Speed (mm/s)	0.1	0.3	0.5	0.7	1	0.1	0.3	0.5
0	40	40	40	35	30	10	10	10
20	40	40	40	35	30	10	10	10
40	40	40	40	35	30	10	10	10
65	40	40	40	30	30	10	10	10
85	40	40	35	30	30	10	10	10
105	40	40	35	30	30	10	6	6
130	40	40	35	30	30	4	4	4
150	40	35	35	29	24	2	2	2
175	33	24	22	19	12			

<When ambient temperature is 5°C or below>

Lead 10

Orientation	Horizontal					Vertical		
	Acceleration (G)							
Speed (mm/s)	0.1	0.3	0.5	0.7	1	0.1	0.3	0.5
0	11	11	9	9	7	2	2	2
85	11	11	9	9	7	2	2	2
175	11	11	8	7	5	2	2	2
260	11	11	7	4	2	2	2	2
350	11	11	7	3	1	2	2	2
435	11	10	6	3	1	1.5	1	1

Lead 5

Orientation	Horizontal					Vertical		
	Acceleration (G)							
Speed (mm/s)	0.1	0.3	0.5	0.7	1	0.1	0.3	0.5
0	23	23	21	18	18	4	4	4
40	23	23	21	18	18	4	4	4
85	23	23	21	18	18	4	4	4
130	23	23	21	18	18	4	4	4
175	23	23	21	16	14	4	4	4
215	23	23	21	14	12	4	4	4
260	23	22	18	12	8	4	4	4

Lead 2.5

Orientation	Horizontal					Vertical		
	Acceleration (G)							
Speed (mm/s)	0.1	0.3	0.5	0.7	1	0.1	0.3	0.5
0	40	40	40	35	30	10	10	10
20	40	40	40	35	30	10	10	10
40	40	40	40	35	30	10	10	10
65	40	40	40	30	30	10	10	10
85	40	40	35	30	30	10	10	10
105	40	40	35	30	30	10	6	6

■ RCP6W/RCP6SW-RR6C

<When ambient temperature exceeds 5°C>

Lead 12

Orientation	Horizontal					Vertical		
	Acceleration (G)							
Speed (mm/s)	0.1	0.3	0.5	0.7	1	0.1	0.3	0.5
0	25	25	18	16	12	4	4	4
105	25	25	18	16	12	4	4	4
210	25	25	17	14	10	4	4	4
315	25	25	15	10	6	4	4	4
420	20	20	10	10	6	4	4	4
525	15	15	8	6	4.5	2	1	1
630		8	3	2	1			

Lead 6

Orientation	Horizontal					Vertical		
	Acceleration (G)							
Speed (mm/s)	0.1	0.3	0.5	0.7	1	0.1	0.3	0.5
0	40	40	35	30	25	10	10	10
55	40	40	35	30	25	10	10	10
105	40	40	35	30	25	10	10	10
160	40	40	35	25	25	10	10	10
210	40	40	30	25	20	9	9	9
265	40	40	27.5	22.5	18	8	8	7
315	40	35	21	20	14	4	4	4
370	38	16	10	8	6	2	2	2
420	28	7	6					

Lead 3

Orientation	Horizontal					Vertical		
	Acceleration (G)							
Speed (mm/s)	0.1	0.3	0.5	0.7	1	0.1	0.3	0.5
0	60	60	50	45	40	20	20	20
20	60	60	50	45	40	20	20	20
45	60	60	50	45	40	20	20	20
70	60	60	50	45	40	20	20	20
105	60	60	50	45	40	20	20	20
130	60	60	50	40	30	18	14	10
155	60	50	40	30	25	14	10	6
180	60	40	35	25	20	9	6	5
210	60	26	22	20	14	6	4	4

<When ambient temperature is 5°C or below>

Lead 12

Orientation	Horizontal					Vertical		
	Acceleration (G)							
Speed (mm/s)	0.1	0.3	0.5	0.7	1	0.1	0.3	0.5
0	25	25	18	16	12	4	4	4
105	25	25	18	16	12	4	4	4
210	25	25	17	14	10	4	4	4
315	25	25	15	10	6	4	4	4
420	20	20	10	10	6	4	4	4
525	15	15	8	6	4.5	2	1	1

Lead 6

Orientation	Horizontal					Vertical		
	Acceleration (G)							
Speed (mm/s)	0.1	0.3	0.5	0.7	1	0.1	0.3	0.5
0	40	40	35	30	25	10	10	10
55	40	40	35	30	25	10	10	10
105	40	40	35	30	25	10	10	10
160	40	40	35	25	25	10	10	10
210	40	40	30	25	20	9	9	9
265	40	40	27.5	22.5	18	8	8	7
315	40	35	21	20	14	4	4	4

Lead 3

Orientation	Horizontal					Vertical		
	Acceleration (G)							
Speed (mm/s)	0.1	0.3	0.5	0.7	1	0.1	0.3	0.5
0	60	60	50	45	40	20	20	20
20	60	60	50	45	40	20	20	20
45	60	60	50	45	40	20	20	20
70	60	60	50	45	40	20	20	20
105	60	60	50	45	40	20	20	20

High-output Setting Enabled

■ RCP6W/RCP6SW-RA7C

<When ambient temperature exceeds 5°C>

Lead 16

Orientation	Horizontal				Vertical			
	Acceleration (G)							
Speed (mm/s)	0.1	0.3	0.5	0.7	1	0.1	0.3	0.5
0	50	50	40	35	30	8	8	8
140	50	50	40	35	30	8	8	8
280	50	45	32	22	17	6	6	5
420	50	18	9	6	5	1.5	1	0.5

Lead 8

Orientation	Horizontal				Vertical			
	Acceleration (G)							
Speed (mm/s)	0.1	0.3	0.5	0.7	1	0.1	0.3	0.5
0	60	60	50	45	40	18	18	18
70	60	60	50	45	40	18	18	18
140	60	60	50	45	40	16	16	12
210	60	60	40	30	20	8	7	6
280	60	20	9	6	3	3	2	1
350	20							

Lead 4

Orientation	Horizontal				Vertical			
	Acceleration (G)							
Speed (mm/s)	0.1	0.3	0.5	0.7	1	0.1	0.3	0.5
0	80	80	70	65	60	28	28	28
35	80	80	70	65	60	28	28	28
70	80	80	70	65	60	28	28	28
105	80	80	60	50	40	21	20	18
140	67	47	10	6	6	8	6	6

<When ambient temperature is 5°C or below>

Lead 16

Orientation	Horizontal				Vertical			
	Acceleration (G)							
Speed (mm/s)	0.1	0.3	0.5	0.7	1	0.1	0.3	0.5
0	50	50	40	35	30	8	8	8
140	50	50	40	35	30	8	8	8
280	50	45	32	22	17	6	6	5

Lead 8

Orientation	Horizontal				Vertical			
	Acceleration (G)							
Speed (mm/s)	0.1	0.3	0.5	0.7	1	0.1	0.3	0.5
0	60	60	50	45	40	18	18	18
70	60	60	50	45	40	18	18	18
140	60	60	50	45	40	8	8	8

Lead 4

Orientation	Horizontal				Vertical			
	Acceleration (G)							
Speed (mm/s)	0.1	0.3	0.5	0.7	1	0.1	0.3	0.5
0	80	80	70	65	60	28	28	28
35	80	80	70	65	60	28	28	28
70	80	80	70	65	60	28	28	28
105	80	80	60	50	40	6	6	6

■ RCP6W/RCP6SW-RA8C

<When ambient temperature exceeds 5°C>

Lead 20

Orientation	Horizontal		Orientation	Vertical	
	Acceleration (G)			Acceleration (G)	
Speed (mm/s)	0.2		Speed (mm/s)	0.2	
0	30		0	3	
210	30		210	3	
300	30		300	3	
350	14		330	1	

Lead 10

Orientation	Horizontal		Orientation	Vertical	
	Acceleration (G)			Acceleration (G)	
Speed (mm/s)	0.2		Speed (mm/s)	0.2	
0	60		0	35	
130	60		80	35	
160	60		90	34	
170	40		100	28	
180	25		110	23	
190	15		120	18	
200	12		130	15	
			140	12	
			150	10	
			160	8	
			170	6	
			180	4	
			190	3	
			200	2	

Lead 5

Orientation	Horizontal		Orientation	Vertical	
	Acceleration (G)			Acceleration (G)	
Speed (mm/s)	0.1		Speed (mm/s)	0.1	
0	100		0	70	
60	100		45	70	
90	100		60	45	
100	75		70	35	
			80	25	
			90	14	
			100	9	

<When ambient temperature is 5°C or below>

Lead 20

Orientation	Horizontal		Orientation	Vertical	
	Acceleration (G)			Acceleration (G)	
Speed (mm/s)	0.2		Speed (mm/s)	0.2	
0	30		0	3	
210	30		210	3	

Lead 10

Orientation	Horizontal		Orientation	Vertical	
	Acceleration (G)			Acceleration (G)	
Speed (mm/s)	0.2		Speed (mm/s)	0.2	
0	60		0	35	
130	60		80	35	
			90	34	
			100	28	
			110	23	
			120	18	
			130	2	

Lead 5

Orientation	Horizontal		Orientation	Vertical	
	Acceleration (G)			Acceleration (G)	
Speed (mm/s)	0.1		Speed (mm/s)	0.1	
0	100		0	70	
60	100		45	70	
			60	9	

Tables of Payload by Speed/Acceleration

RCP6W Series

Rod Type Side-Mounted Motor Specification

High-output Setting Enabled

■ RCP6W/RCP6SW-RR4R

<When ambient temperature exceeds 5°C>

Lead 10

Orientation	Horizontal					Vertical		
	Acceleration (G)							
Speed (mm/s)	0.1	0.3	0.5	0.7	1	0.1	0.3	0.5
0	11	11	9	9	7	2	2	2
85	11	11	9	9	7	2	2	2
175	11	11	8	7	5	2	2	2
260	11	11	7	4	2	2	2	2
350	11	11	7	3	1	2	2	2
435	11	10	6	3	1	1.5	1	1
525		4	1					

Lead 5

Orientation	Horizontal					Vertical		
	Acceleration (G)							
Speed (mm/s)	0.1	0.3	0.5	0.7	1	0.1	0.3	0.5
0	23	23	21	18	18	4	4	4
40	23	23	21	18	18	4	4	4
85	23	23	21	18	18	4	4	4
130	23	23	21	18	18	4	4	4
175	23	23	21	16	14	4	4	4
215	23	23	21	14	12	4	4	4
260	23	22	18	12	8	4	4	4
305	22	14	8	6	4	3	3	3
350	19	5	1			2	1	1

Lead 2.5

Orientation	Horizontal					Vertical		
	Acceleration (G)							
Speed (mm/s)	0.1	0.3	0.5	0.7	1	0.1	0.3	0.5
0	40	40	40	35	30	10	10	10
20	40	40	40	35	30	10	10	10
40	40	40	40	35	30	10	10	10
65	40	40	40	30	30	10	10	10
85	40	40	35	30	30	10	10	10
105	40	40	35	30	30	10	6	6
130	40	40	35	30	30	4	4	4
150	40	35	35	29	24	2	2	2
175	33	24	22	19	12			

<When ambient temperature is 5°C or below>

Lead 10

Orientation	Horizontal					Vertical		
	Acceleration (G)							
Speed (mm/s)	0.1	0.3	0.5	0.7	1	0.1	0.3	0.5
0	11	11	9	9	7	2	2	2
85	11	11	9	9	7	2	2	2
175	11	11	8	7	5	2	2	2
260	11	11	7	4	2	2	2	2
350	11	11	7	3	1	2	2	2
435	11	10	6	3	1	1.5	1	1

Lead 5

Orientation	Horizontal					Vertical		
	Acceleration (G)							
Speed (mm/s)	0.1	0.3	0.5	0.7	1	0.1	0.3	0.5
0	23	23	21	18	18	4	4	4
40	23	23	21	18	18	4	4	4
85	23	23	21	18	18	4	4	4
130	23	23	21	18	18	4	4	4
175	23	23	21	16	14	4	4	4
215	23	23	21	14	12	4	4	4
260	23	22	18	12	8	4	4	4

Lead 2.5

Orientation	Horizontal					Vertical		
	Acceleration (G)							
Speed (mm/s)	0.1	0.3	0.5	0.7	1	0.1	0.3	0.5
0	40	40	40	35	30	10	10	10
20	40	40	40	35	30	10	10	10
40	40	40	40	35	30	10	10	10
65	40	40	40	30	30	10	10	10
85	40	40	35	30	30	10	10	10
105	40	40	35	30	30	10	6	6

■ RCP6W/RCP6SW-RR6R

<When ambient temperature exceeds 5°C>

Lead 12

Orientation	Horizontal					Vertical		
	Acceleration (G)							
Speed (mm/s)	0.1	0.3	0.5	0.7	1	0.1	0.3	0.5
0	25	25	18	16	12	4	4	4
105	25	25	18	16	12	4	4	4
210	25	25	17	14	10	4	4	4
315	25	25	15	10	6	4	4	4
420	20	20	10	10	6	4	4	4
525	15	15	8	6	4.5	2	1	1
630		8	3	2	1			

Lead 6

Orientation	Horizontal					Vertical		
	Acceleration (G)							
Speed (mm/s)	0.1	0.3	0.5	0.7	1	0.1	0.3	0.5
0	40	40	35	30	25	10	10	10
55	40	40	35	30	25	10	10	10
105	40	40	35	30	25	10	10	10
160	40	40	35	25	25	10	10	10
210	40	40	30	25	20	9	9	9
265	40	40	27.5	22.5	18	8	8	7
315	40	35	21	20	14	4	4	4
370	38	16	10	8	6	2	2	2
420	28	7	6					

Lead 3

Orientation	Horizontal					Vertical		
	Acceleration (G)							
Speed (mm/s)	0.1	0.3	0.5	0.7	1	0.1	0.3	0.5
0	60	60	50	45	40	20	20	20
20	60	60	50	45	40	20	20	20
45	60	60	50	45	40	20	20	20
70	60	60	50	45	40	20	20	20
105	60	60	50	45	40	20	20	20
130	60	60	50	40	30	18	14	10
155	60	50	40	30	25	14	10	6
180	60	40	35	25	20	9	6	5
210	60	26	22	20	14	6	4	4

<When ambient temperature is 5°C or below>

Lead 12

Orientation	Horizontal					Vertical		
	Acceleration (G)							
Speed (mm/s)	0.1	0.3	0.5	0.7	1	0.1	0.3	0.5
0	25	25	18	16	12	4	4	4
105	25	25	18	16	12	4	4	4
210	25	25	17	14	10	4	4	4
315	25	25	15	10	6	4	4	4
420	20	20	10	10	6	4	4	4
525	15	15	8	6	4.5	2	1	1

Lead 6

Orientation	Horizontal					Vertical		
	Acceleration (G)							
Speed (mm/s)	0.1	0.3	0.5	0.7	1	0.1	0.3	0.5
0	40	40	35	30	25	10	10	10
55	40	40	35	30	25	10	10	10
105	40	40	35	30	25	10	10	10
160	40	40	35	25	25	10	10	10
210	40	40	30	25	20	9	9	9
265	40	40	27.5	22.5	18	8	8	7
315	40	35	21	20	14	4	4	4

Lead 3

Orientation	Horizontal					Vertical		
	Acceleration (G)							
Speed (mm/s)	0.1	0.3	0.5	0.7	1	0.1	0.3	0.5
0	60	60	50	45	40	20	20	20
20	60	60	50	45	40	20	20	20
45	60	60	50	45	40	20	20	20
70	60	60	50	45	40	20	20	20
105	60	60	50	45	40	20	20	20

High-output Setting Enabled

■ RCP6W/RCP6SW-RR47R

<When ambient temperature exceeds 5°C>

Lead 16

Orientation	Horizontal				Vertical			
	Acceleration (G)							
Speed (mm/s)	0.1	0.3	0.5	0.7	1	0.1	0.3	0.5
0	50	50	40	35	30	8	8	8
140	50	50	40	35	30	8	8	8
280	50	45	32	22	17	6	6	5
420	50	18	9	6	5	1.5	1	0.5

Lead 8

Orientation	Horizontal				Vertical			
	Acceleration (G)							
Speed (mm/s)	0.1	0.3	0.5	0.7	1	0.1	0.3	0.5
0	60	60	50	45	40	18	18	18
70	60	60	50	45	40	18	18	18
140	60	60	50	45	40	16	16	12
210	60	60	40	30	20	8	7	6
280	60	20	9	6	3	3	2	1
350	20							

Lead 4

Orientation	Horizontal				Vertical			
	Acceleration (G)							
Speed (mm/s)	0.1	0.3	0.5	0.7	1	0.1	0.3	0.5
0	80	80	70	65	60	28	28	28
35	80	80	70	65	60	28	28	28
70	80	80	70	65	60	28	28	28
105	80	80	60	50	40	21	20	18
140	67	47	10	6	6	8	6	6

<When ambient temperature is 5°C or below>

Lead 16

Orientation	Horizontal				Vertical			
	Acceleration (G)							
Speed (mm/s)	0.1	0.3	0.5	0.7	1	0.1	0.3	0.5
0	50	50	40	35	30	8	8	8
140	50	50	40	35	30	8	8	8
280	50	45	32	22	17	6	6	5

Lead 8

Orientation	Horizontal				Vertical			
	Acceleration (G)							
Speed (mm/s)	0.1	0.3	0.5	0.7	1	0.1	0.3	0.5
0	60	60	50	45	40	18	18	18
70	60	60	50	45	40	18	18	18
140	60	60	50	45	40	8	8	8

Lead 4

Orientation	Horizontal				Vertical			
	Acceleration (G)							
Speed (mm/s)	0.1	0.3	0.5	0.7	1	0.1	0.3	0.5
0	80	80	70	65	60	28	28	28
35	80	80	70	65	60	28	28	28
70	80	80	70	65	60	28	28	28
105	80	80	60	50	40	6	6	6

■ RCP6W/RCP6SW-RR48R

<When ambient temperature exceeds 5°C>

Lead 20

Orientation	Horizontal		Orientation	Vertical	
	Acceleration (G)			Acceleration (G)	
Speed (mm/s)	0.2		Speed (mm/s)	0.2	
0	30		0	3	
210	30		210	3	
300	30		300	3	
350	14		330	1	

Lead 10

Orientation	Horizontal		Orientation	Vertical	
	Acceleration (G)			Acceleration (G)	
Speed (mm/s)	0.2		Speed (mm/s)	0.2	
0	60		0	35	
130	60		80	35	
160	60		90	34	
170	40		100	28	
180	25		110	23	
190	15		120	18	
200	12		130	15	
			140	12	
			150	10	
			160	8	
			170	6	
			180	4	
			190	3	
			200	2	

Lead 5

Orientation	Horizontal		Orientation	Vertical	
	Acceleration (G)			Acceleration (G)	
Speed (mm/s)	0.1		Speed (mm/s)	0.1	
0	100		0	70	
60	100		45	70	
90	100		60	45	
100	75		70	35	
			80	25	
			90	14	
			100	9	

<When ambient temperature is 5°C or below>

Lead 20

Orientation	Horizontal		Orientation	Vertical	
	Acceleration (G)			Acceleration (G)	
Speed (mm/s)	0.2		Speed (mm/s)	0.2	
0	30		0	3	
210	30		210	3	

Lead 10

Orientation	Horizontal		Orientation	Vertical	
	Acceleration (G)			Acceleration (G)	
Speed (mm/s)	0.2		Speed (mm/s)	0.2	
0	60		0	35	
130	60		80	35	
			90	34	
			100	28	
			110	23	
			120	18	
			130	2	

Lead 5

Orientation	Horizontal		Orientation	Vertical	
	Acceleration (G)			Acceleration (G)	
Speed (mm/s)	0.1		Speed (mm/s)	0.1	
0	100		0	70	
60	100		45	70	
			60	9	

Tables of Payload by Speed/Acceleration

RCP6W Series

Rod Type Motor Coupling Specification

High-output Setting Enabled

■ RCP6W/RCP6SW-WRA10C

<When ambient temperature exceeds 5°C>

Lead 10

Orientation	Horizontal				
	Acceleration (G)				
Speed (mm/s)	0.1	0.3	0.5	0.7	1
0	11.5	11.5	8.5	8.5	6.5
85	11.5	11.5	8.5	8.5	6.5
175	11.5	11.5	8.5	8.5	3.5
260	11.5	11.5	8.5	6	2.5
350	11.5	11.5	8.5	5	2
435	11.5	8.5	6	3.5	1.5
525	10.5	4			

Lead 5

Orientation	Horizontal					Vertical		
	Acceleration (G)							
Speed (mm/s)	0.1	0.3	0.5	0.7	1	0.1	0.3	0.5
0	28	25	22	20	20	4	4	4
40	28	25	22	20	20	4	4	4
85	28	25	22	20	20	4	4	4
130	28	25	22	20	20	4	4	4
175	28	25	22	20	18	3	3	3
215	28	25	22	18	13.5	2	2	2
260	28	25	20.5	15.5	11			
305	28	17.5	12.5	10	7.5			
350	28	9.5	5.5	3.5				

Lead 2.5

Orientation	Horizontal					Vertical		
	Acceleration (G)							
Speed (mm/s)	0.1	0.3	0.5	0.7	1	0.1	0.3	0.5
0	40	40	40	35	30	10	10	10
20	40	40	40	35	30	10	10	10
40	40	40	40	35	30	10	10	10
65	40	40	40	35	30	10	10	10
85	40	40	40	35	30	10	10	10
105	40	35	35	35	30	10	10	10
130	40	35	35	30	30	3.5	3.5	3.5
150	40	35	35	28	24	1.5	1.5	1.5
175	40	28	26	18	11			

<When ambient temperature is 5°C or below>

Lead 10

Orientation	Horizontal				
	Acceleration (G)				
Speed (mm/s)	0.1	0.3	0.5	0.7	1
0	11.5	11.5	8.5	8.5	6.5
85	11.5	11.5	8.5	8.5	6.5
175	11.5	11.5	8.5	8.5	3.5
260	11.5	11.5	8.5	6	2.5
350	11.5	11.5	8.5	5	2

Lead 5

Orientation	Horizontal					Vertical		
	Acceleration (G)							
Speed (mm/s)	0.1	0.3	0.5	0.7	1	0.1	0.3	0.5
0	28	25	22	20	20	4	4	4
40	28	25	22	20	20	4	4	4
85	28	25	22	20	20	4	4	4
130	28	25	22	20	20	4	4	4
175	28	25	22	20	18	3	3	3
215	28	25	22	18	13.5	2	2	2

Lead 2.5

Orientation	Horizontal					Vertical		
	Acceleration (G)							
Speed (mm/s)	0.1	0.3	0.5	0.7	1	0.1	0.3	0.5
0	40	40	40	35	30	10	10	10
20	40	40	40	35	30	10	10	10
40	40	40	40	35	30	10	10	10
65	40	40	40	35	30	10	10	10

■ RCP6W/RCP6SW-WRA12C

<When ambient temperature exceeds 5°C>

Lead 12

Orientation	Horizontal				
	Acceleration (G)				
Speed (mm/s)	0.1	0.3	0.5	0.7	1
0	30	25	18	16	10
80	30	25	18	16	10
200	30	25	15	13	9
320	30	25	15	9	6
440	25	20	12	8	4.5
560		7.5	3.5	1	

Lead 6

Orientation	Horizontal					Vertical		
	Acceleration (G)							
Speed (mm/s)	0.1	0.3	0.5	0.7	1	0.1	0.3	0.5
0	55	40	35	30	25	4	4	4
40	55	40	35	30	25	4	4	4
100	55	40	35	30	25	4	4	4
160	55	40	32.5	25	25	4	4	4
220	55	40	27.5	22	16	4	4	3
280	55	35	25	18	11			
340	55	23	14	12	8			
400	38	7	2	1	1			

Lead 3

Orientation	Horizontal					Vertical		
	Acceleration (G)							
Speed (mm/s)	0.1	0.3	0.5	0.7	1	0.1	0.3	0.5
0	70	60	50	45	40	14	14	14
20	70	60	50	45	40	14	14	14
50	70	60	50	45	40	14	14	14
80	70	60	50	45	40	14	14	14
110	70	60	50	45	40	14	14	14
140	70	50	40	30	25	10	10	5
170	70	40	35	25	20			
200	70	26	26	20	14			
225	50	7	4	3	3			

<When ambient temperature is 5°C or below>

Lead 12

Orientation	Horizontal				
	Acceleration (G)				
Speed (mm/s)	0.1	0.3	0.5	0.7	1
0	30	25	18	16	10
80	30	25	18	16	10
200	30	25	15	13	9
320	30	25	15	9	6

Lead 6

Orientation	Horizontal					Vertical		
	Acceleration (G)							
Speed (mm/s)	0.1	0.3	0.5	0.7	1	0.1	0.3	0.5
0	55	40	35	30	25	4	4	4
40	55	40	35	30	25	4	4	4
100	55	40	35	30	25	4	4	4
160	55	40	32.5	25	25	4	4	4
220	55	40	27.5	22	16	4	4	3

Lead 3

Orientation	Horizontal					Vertical		
	Acceleration (G)							
Speed (mm/s)	0.1	0.3	0.5	0.7	1	0.1	0.3	0.5
0	70	60	50	45	40	14	14	14
20	70	60	50	45	40	14	14	14
50	70	60	50	45	40	14	14	14
80	70	60	50	45	40	14	14	14

High-output Setting Enabled

■ RCP6W/RCP6SW-WRA14C

<When ambient temperature exceeds 5°C>

Lead 16

Orientation	Horizontal				
Speed (mm/s)	Acceleration (G)				
	0.1	0.3	0.5	0.7	1
0	50	50	40	35	30
140	50	50	40	35	30
280	50	32	25	17	12
420	23	7	2		

Lead 8

Orientation	Horizontal					Vertical		
	Acceleration (G)							
Speed (mm/s)	0.1	0.3	0.5	0.7	1	0.1	0.3	0.5
	0	65	65	55	50	45	11.5	11.5
70	65	65	55	50	45	11.5	11.5	11.5
140	65	65	51	41	41	9.5	9.5	6.5
210	65	56	28	20	15	1.5	1.5	
280	51	14	1					

Lead 4

Orientation	Horizontal					Vertical		
	Acceleration (G)							
Speed (mm/s)	0.1	0.3	0.5	0.7	1	0.1	0.3	0.5
	0	85	80	70	65	60	21.5	19.5
35	85	80	70	65	60	21.5	19.5	19.5
70	85	80	70	65	60	21.5	19.5	19.5
105	85	80	51	46	40	15.5	13.5	12
130	85	41	10	6	2	3.5		

<When ambient temperature is 5°C or below>

Lead 16

Orientation	Horizontal				
Speed (mm/s)	Acceleration (G)				
	0.1	0.3	0.5	0.7	1
0	50	50	40	35	30
140	50	50	40	35	30
280	50	32	25	17	12

Lead 8

Orientation	Horizontal					Vertical		
	Acceleration (G)							
Speed (mm/s)	0.1	0.3	0.5	0.7	1	0.1	0.3	0.5
	0	65	65	55	50	45	11.5	11.5
70	65	65	55	50	45	11.5	11.5	11.5
140	65	65	51	41	41	9.5	9.5	6.5

Lead 4

Orientation	Horizontal					Vertical		
	Acceleration (G)							
Speed (mm/s)	0.1	0.3	0.5	0.7	1	0.1	0.3	0.5
	0	85	80	70	65	60	21.5	19.5
35	85	80	70	65	60	21.5	19.5	19.5
70	85	80	70	65	60	21.5	19.5	19.5

■ RCP6W/RCP6SW-WRA16C

<When ambient temperature exceeds 5°C>

Lead 20

Orientation	Horizontal
Speed (mm/s)	Acceleration (G)
0	30
240	30
300	30
360	12

Lead 10

Orientation	Horizontal		Orientation	Vertical	
	Speed (mm/s)	Acceleration (G)		Speed (mm/s)	Acceleration (G)
		0.2			0.2
0	60		0	30.5	
150	60		88	30.5	
200	23		100	20.5	
220	2		110	15.5	
			120	12.5	
			130	10.5	
			140	7.5	
			150	3.5	
			160	1.5	

Lead 5

Orientation	Horizontal		Orientation	Vertical	
	Speed (mm/s)	Acceleration (G)		Speed (mm/s)	Acceleration (G)
		0.1			0.1
0	100		0	59	
100	100		48	59	
110	45		60	29	
			70	24	
			80	14	
			90	5	

<When ambient temperature is 5°C or below>

Lead 20

Orientation	Horizontal
Speed (mm/s)	Acceleration (G)
0	30
240	30

Lead 10

Orientation	Horizontal		Orientation	Vertical	
	Speed (mm/s)	Acceleration (G)		Speed (mm/s)	Acceleration (G)
		0.2			0.2
0	60		0	30.5	
120	60		88	30.5	
			100	20.5	
			110	15.5	
			120	12.5	

Lead 5

Orientation	Horizontal		Orientation	Vertical	
	Speed (mm/s)	Acceleration (G)		Speed (mm/s)	Acceleration (G)
		0.1			0.1
0	100		0	59	
80	100		48	59	
			60	29	
			70	24	
			80	14	

Tables of Payload by Speed/Acceleration

RCP6W Series

Rod Type Side-Mounted Motor Specification

High-output Setting Enabled

■ RCP6W/RCP6SW-WRA10R

<When ambient temperature exceeds 5°C>

Lead 10

Orientation	Horizontal				
	Acceleration (G)				
Speed (mm/s)	0.1	0.3	0.5	0.7	1
0	11.5	11.5	8.5	8.5	6.5
85	11.5	11.5	8.5	8.5	6.5
175	11.5	11.5	8.5	8.5	3.5
260	11.5	11.5	8.5	6	2.5
350	11.5	11.5	8.5	5	2
435	11.5	8.5	6	3.5	1.5
525	10.5	4			

Lead 5

Orientation	Horizontal					Vertical		
	Acceleration (G)							
Speed (mm/s)	0.1	0.3	0.5	0.7	1	0.1	0.3	0.5
0	28	25	22	20	20	4	4	4
40	28	25	22	20	20	4	4	4
85	28	25	22	20	20	4	4	4
130	28	25	22	20	20	4	4	4
175	28	25	22	20	18	3	3	3
215	28	25	22	18	13.5	2	2	2
260	28	25	20.5	15.5	11			
305	28	17.5	12.5	10	7.5			
350	28	9.5	5.5	3.5				

Lead 2.5

Orientation	Horizontal					Vertical		
	Acceleration (G)							
Speed (mm/s)	0.1	0.3	0.5	0.7	1	0.1	0.3	0.5
0	40	40	40	35	30	10	10	10
20	40	40	40	35	30	10	10	10
40	40	40	40	35	30	10	10	10
65	40	40	40	35	30	10	10	10
85	40	40	40	35	30	10	10	10
105	40	35	35	35	30	10	10	10
130	40	35	35	30	30	3.5	3.5	3.5
150	40	35	35	28	24	1.5	1.5	1.5
175	40	28	26	18	11			

<When ambient temperature is 5°C or below>

Lead 10

Orientation	Horizontal				
	Acceleration (G)				
Speed (mm/s)	0.1	0.3	0.5	0.7	1
0	11.5	11.5	8.5	8.5	6.5
85	11.5	11.5	8.5	8.5	6.5
175	11.5	11.5	8.5	8.5	3.5
260	11.5	11.5	8.5	6	2.5
350	11.5	11.5	8.5	5	2

Lead 5

Orientation	Horizontal					Vertical		
	Acceleration (G)							
Speed (mm/s)	0.1	0.3	0.5	0.7	1	0.1	0.3	0.5
0	28	25	22	20	20	4	4	4
40	28	25	22	20	20	4	4	4
85	28	25	22	20	20	4	4	4
130	28	25	22	20	20	4	4	4
175	28	25	22	20	18	3	3	3
215	28	25	22	18	13.5	2	2	2

Lead 2.5

Orientation	Horizontal					Vertical		
	Acceleration (G)							
Speed (mm/s)	0.1	0.3	0.5	0.7	1	0.1	0.3	0.5
0	40	40	40	35	30	10	10	10
20	40	40	40	35	30	10	10	10
40	40	40	40	35	30	10	10	10
65	40	40	40	35	30	10	10	10

■ RCP6W/RCP6SW-WRA12R

<When ambient temperature exceeds 5°C>

Lead 12

Orientation	Horizontal				
	Acceleration (G)				
Speed (mm/s)	0.1	0.3	0.5	0.7	1
0	30	25	18	16	10
80	30	25	18	16	10
200	30	25	15	13	9
320	30	25	15	9	6
440	25	20	12	8	4.5
560		7.5	3.5	1	

Lead 6

Orientation	Horizontal					Vertical		
	Acceleration (G)							
Speed (mm/s)	0.1	0.3	0.5	0.7	1	0.1	0.3	0.5
0	55	40	35	30	25	4	4	4
40	55	40	35	30	25	4	4	4
100	55	40	35	30	25	4	4	4
160	55	40	32.5	25	25	4	4	4
220	55	40	27.5	22	16	4	4	3
280	55	35	25	18	11			
340	55	23	14	12	8			
400	38	7	2	1	1			

Lead 3

Orientation	Horizontal					Vertical		
	Acceleration (G)							
Speed (mm/s)	0.1	0.3	0.5	0.7	1	0.1	0.3	0.5
0	70	60	50	45	40	14	14	14
20	70	60	50	45	40	14	14	14
50	70	60	50	45	40	14	14	14
80	70	60	50	45	40	14	14	14
110	70	60	50	45	40	14	14	14
140	70	50	40	30	25	10	10	5
170	70	40	35	25	20			
200	70	26	26	20	14			
225	50	7	4	3	3			

<When ambient temperature is 5°C or below>

Lead 12

Orientation	Horizontal				
	Acceleration (G)				
Speed (mm/s)	0.1	0.3	0.5	0.7	1
0	30	25	18	16	10
80	30	25	18	16	10
200	30	25	15	13	9
320	30	25	15	9	6

Lead 6

Orientation	Horizontal					Vertical		
	Acceleration (G)							
Speed (mm/s)	0.1	0.3	0.5	0.7	1	0.1	0.3	0.5
0	55	40	35	30	25	4	4	4
40	55	40	35	30	25	4	4	4
100	55	40	35	30	25	4	4	4
160	55	40	32.5	25	25	4	4	4
220	55	40	27.5	22	16	4	4	3

Lead 3

Orientation	Horizontal					Vertical		
	Acceleration (G)							
Speed (mm/s)	0.1	0.3	0.5	0.7	1	0.1	0.3	0.5
0	70	60	50	45	40	14	14	14
20	70	60	50	45	40	14	14	14
50	70	60	50	45	40	14	14	14
80	70	60	50	45	40	14	14	14

RCP6W Series Rod Type Side-Mounted Motor Specification

High-output Setting Enabled

■ RCP6W/RCP6SW-WRA14R

<When ambient temperature exceeds 5°C>

Lead 16

Orientation	Horizontal				
Speed (mm/s)	Acceleration (G)				
	0.1	0.3	0.5	0.7	1
0	50	50	40	35	30
140	50	50	40	35	30
280	50	32	25	17	12
420	23	7	2		

Lead 8

Orientation	Horizontal					Vertical		
	Acceleration (G)							
Speed (mm/s)	0.1	0.3	0.5	0.7	1	0.1	0.3	0.5
	0	65	65	55	50	45	11.5	11.5
70	65	65	55	50	45	11.5	11.5	11.5
140	65	65	51	41	41	9.5	9.5	6.5
210	65	56	28	20	15	1.5	1.5	
280	51	14	1					

Lead 4

Orientation	Horizontal					Vertical		
	Acceleration (G)							
Speed (mm/s)	0.1	0.3	0.5	0.7	1	0.1	0.3	0.5
	0	85	80	70	65	60	21.5	19.5
35	85	80	70	65	60	21.5	19.5	19.5
70	85	80	70	65	60	21.5	19.5	19.5
105	85	80	51	46	40	15.5	13.5	12
130	85	41	10	6	2	3.5		

<When ambient temperature is 5°C or below>

Lead 16

Orientation	Horizontal				
Speed (mm/s)	Acceleration (G)				
	0.1	0.3	0.5	0.7	1
0	50	50	40	35	30
140	50	50	40	35	30
280	50	32	25	17	12

Lead 8

Orientation	Horizontal					Vertical		
	Acceleration (G)							
Speed (mm/s)	0.1	0.3	0.5	0.7	1	0.1	0.3	0.5
	0	65	65	55	50	45	11.5	11.5
70	65	65	55	50	45	11.5	11.5	11.5
140	65	65	51	41	41	9.5	9.5	6.5

Lead 4

Orientation	Horizontal					Vertical		
	Acceleration (G)							
Speed (mm/s)	0.1	0.3	0.5	0.7	1	0.1	0.3	0.5
	0	85	80	70	65	60	21.5	19.5
35	85	80	70	65	60	21.5	19.5	19.5
70	85	80	70	65	60	21.5	19.5	19.5

■ RCP6W/RCP6SW-WRA16R

<When ambient temperature exceeds 5°C>

Lead 20

Orientation	Horizontal
Speed (mm/s)	Acceleration (G)
0	30
240	30
300	30
360	12

Lead 10

Orientation	Horizontal		Orientation	Vertical	
	Speed (mm/s)	Acceleration (G)		Speed (mm/s)	Acceleration (G)
		0.2			0.2
0	60		0	30.5	
150	60		88	30.5	
200	23		100	20.5	
220	2		110	15.5	
			120	12.5	
			130	10.5	
			140	7.5	
			150	3.5	
			160	1.5	

Lead 5

Orientation	Horizontal		Orientation	Vertical	
	Speed (mm/s)	Acceleration (G)		Speed (mm/s)	Acceleration (G)
		0.1			0.1
0	100		0	59	
100	100		48	59	
110	45		60	29	
			70	24	
			80	14	
			90	5	

<When ambient temperature is 5°C or below>

Lead 20

Orientation	Horizontal
Speed (mm/s)	Acceleration (G)
0	30
240	30

Lead 10

Orientation	Horizontal		Orientation	Vertical	
	Speed (mm/s)	Acceleration (G)		Speed (mm/s)	Acceleration (G)
		0.2			0.2
0	60		0	30.5	
120	60		88	30.5	
			100	20.5	
			110	15.5	
			120	12.5	

Lead 5

Orientation	Horizontal		Orientation	Vertical	
	Speed (mm/s)	Acceleration (G)		Speed (mm/s)	Acceleration (G)
		0.1			0.1
0	100		0	59	
80	100		48	59	
			60	29	
			70	24	
			80	14	

Foreword
Slider Type
Wide Slider Type
Rod Type
Radial Cylinder
Wide Radial Cylinder
Table Type
Cleanroom Slider
Cleanroom Wide Slider
Dust/Splash-Proof Rod
Dust/Splash-Proof Radial Cylinder
Dust/Splash-Proof Wide Radial Cylinder
Options
Reference Data
Controller

Selection Guideline for Allowable Load Mass

The radial cylinder has a built-in guide, so loads up to a certain level can be applied to the rod without using an external guide.

Refer to the graphs below for the allowable load mass.

If the allowable load mass is exceeded, please add an external guide.

■ Allowable Load Mass for Horizontally Mounted RCP6(S)-RRA Series * RCP6(S)W is the same.

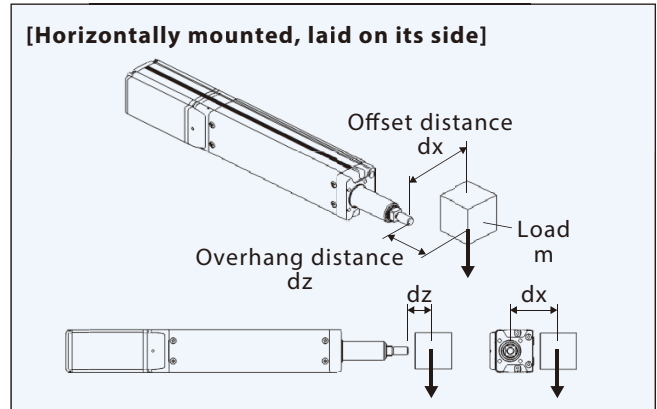
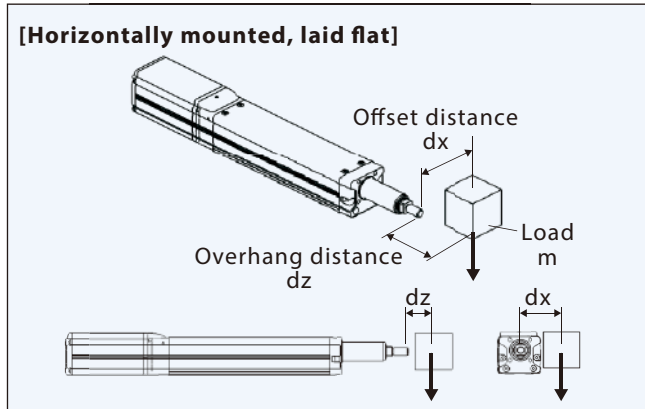

■ RCP6(S)-RRA4/RRA6/RRA7/RRA8

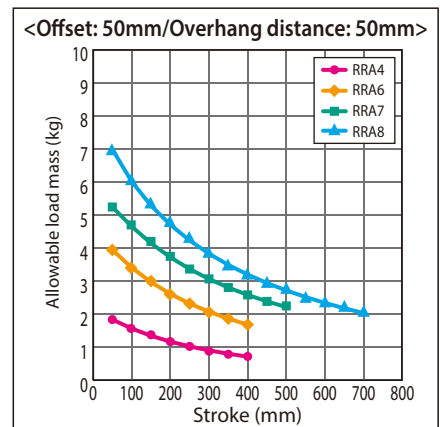
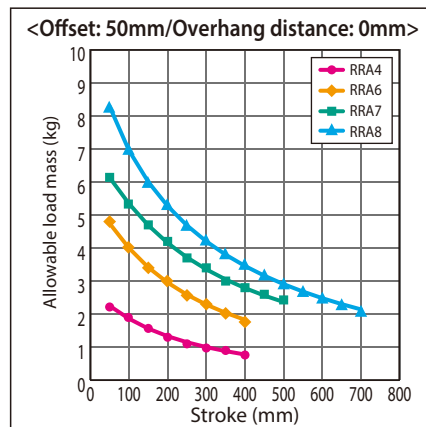
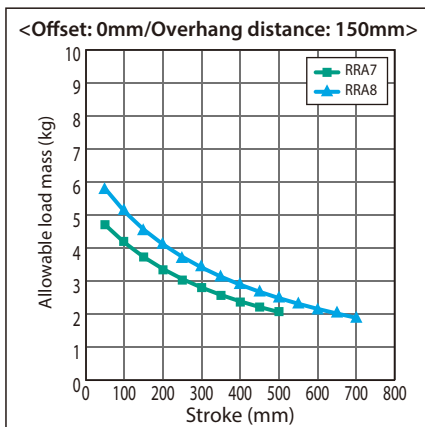
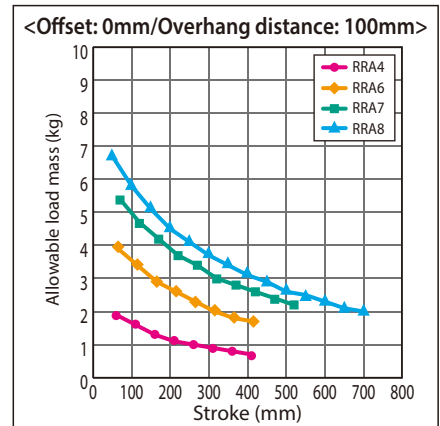
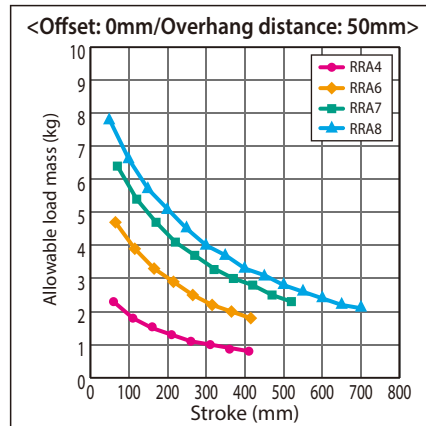
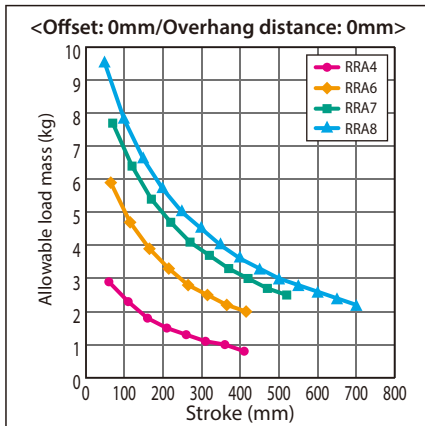

Allowable load calculation conditions.

Load mass corresponding to a product service life of 5,000 km, considering moments generated by acceleration/deceleration. (Acceleration: 1G, speed 500mm/s)

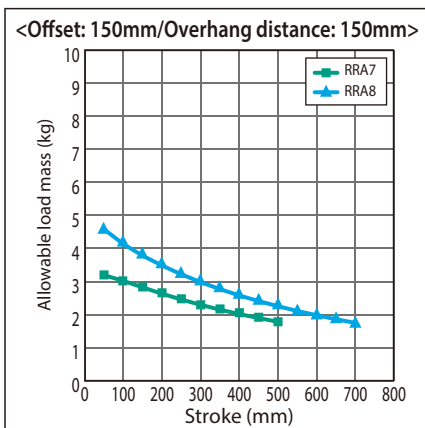
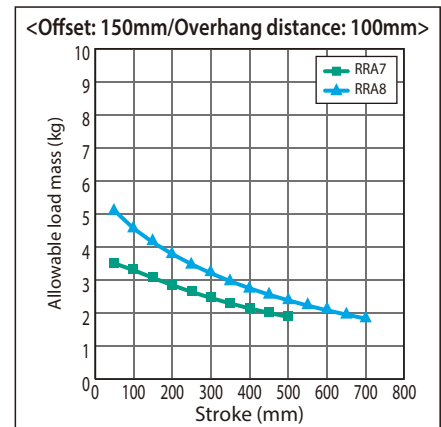
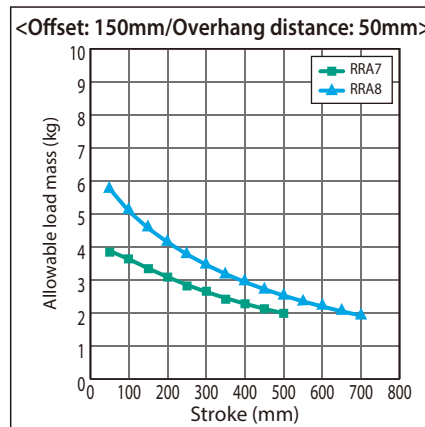
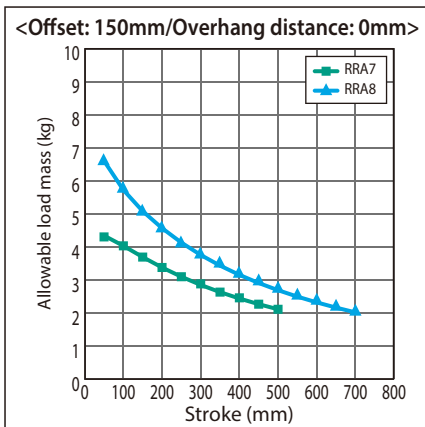
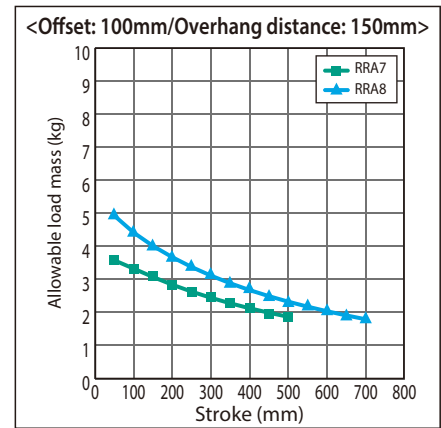
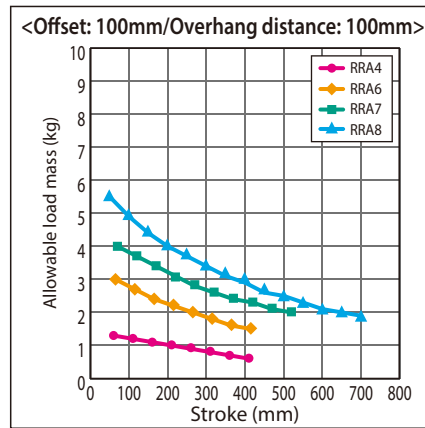
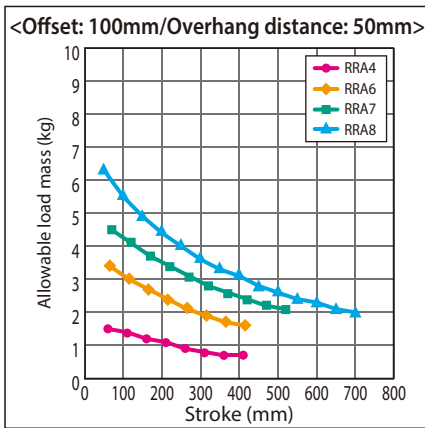
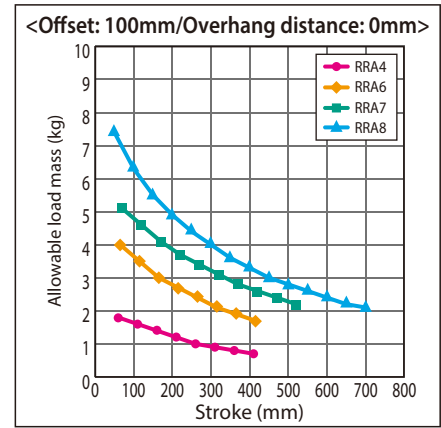
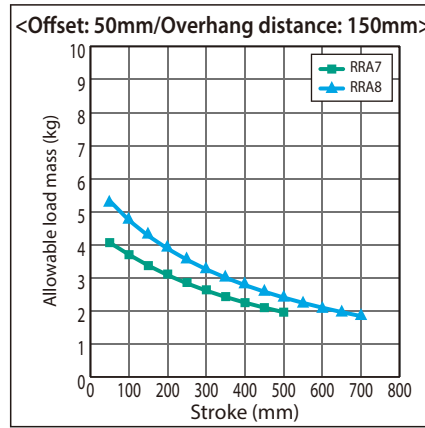
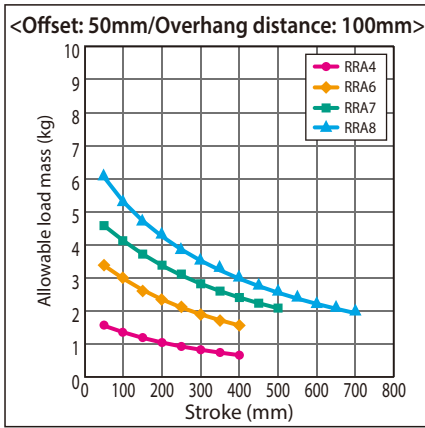

Allowable load calculation conditions.

Load mass corresponding to a product service life of 5,000 km, considering moments generated by acceleration/deceleration. (Acceleration: 1G, speed 500mm/s)

Selection Guideline for Allowable Load Mass

■ Allowable Load Mass for Vertically Mounted RCP6(S)-RRA Series * Differs for RCP6(S)W in some cases depending on lead.

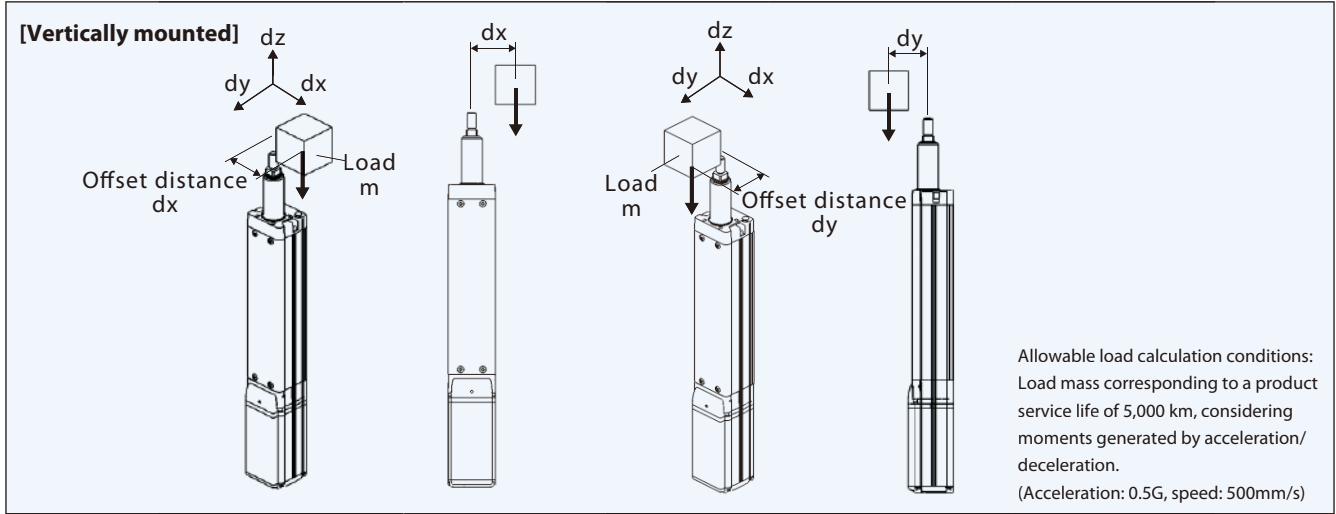

■ RCP6(S)-RRA4

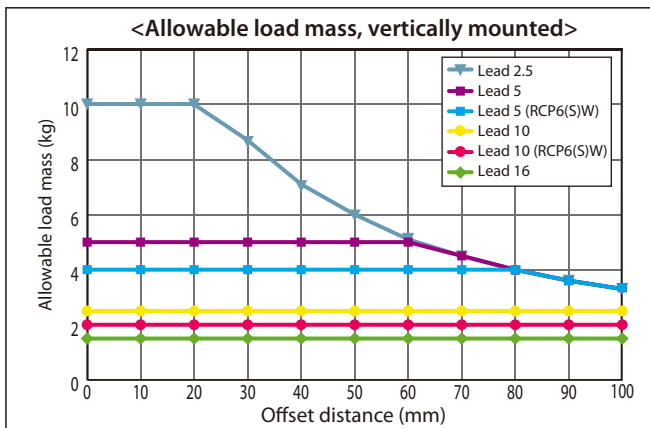

■ RCP6(S)-RRA6

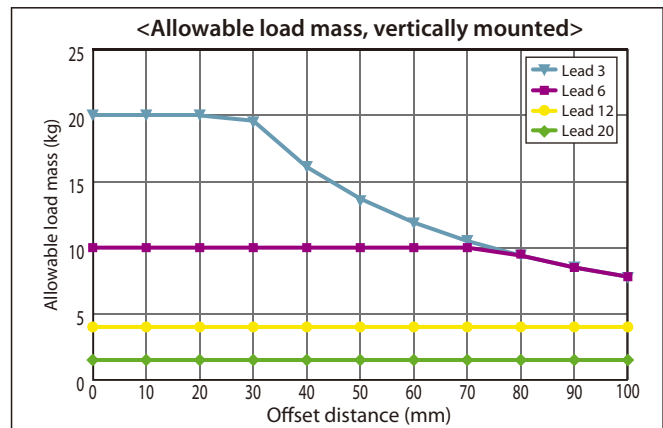

■ RCP6(S)-RRA7

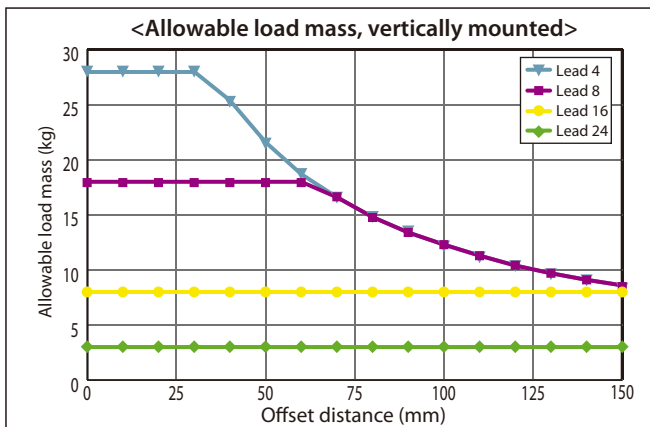

■ RCP6(S)-RRA8

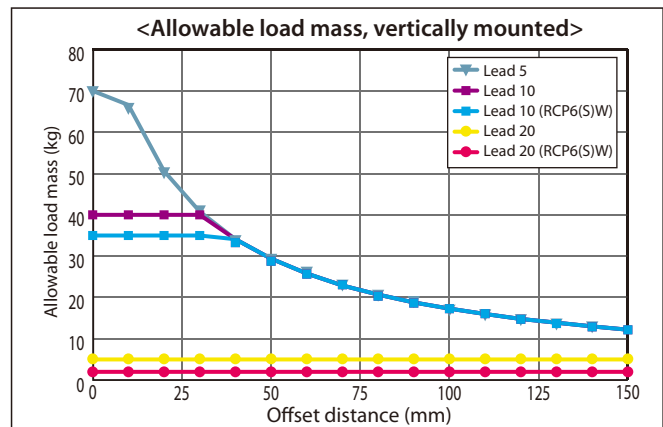

■ Allowable Load Mass for RCP6(S)-WRA Series * Differs for RCP6(S)W in some cases depending on lead.

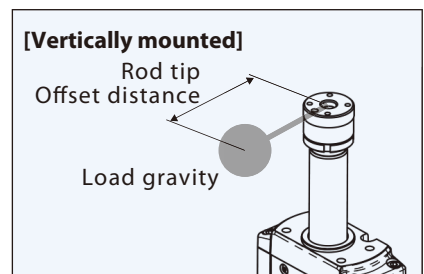
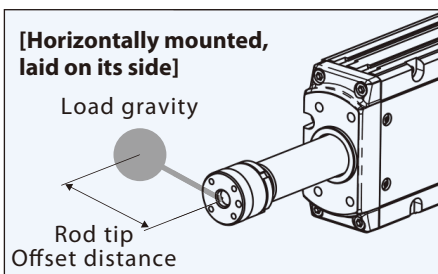
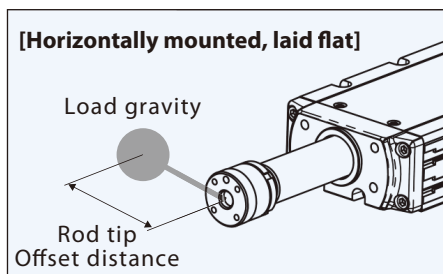

■ RCP6(S)-WRA10/WRA12

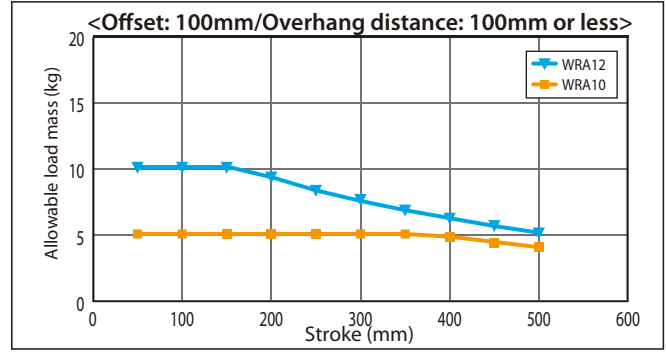
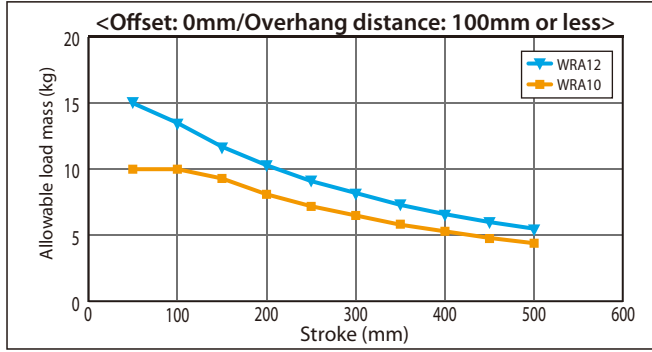

■ RCP6(S)-WRA14/WRA16

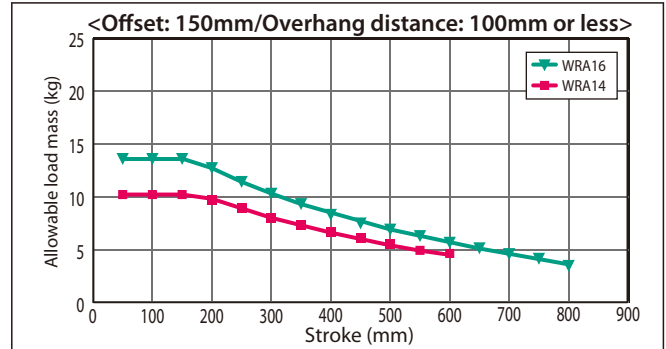
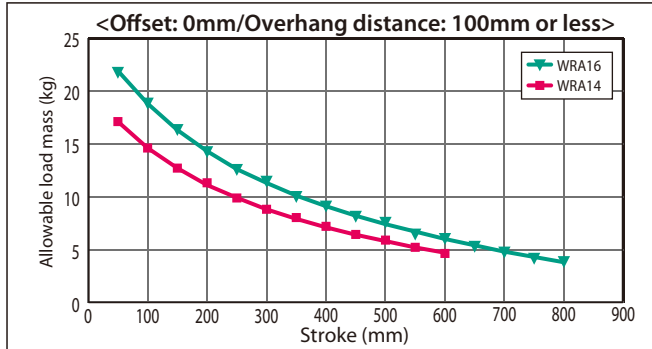

Allowable load calculation conditions: Load mass corresponding to a product service life of 5,000 km, considering moments generated by acceleration/deceleration. (Acceleration: 1G, speed: 500mm/s. *For WRA16 type, acceleration: 0.2G, speed: 500mm/s)

■ RCP6(S)-WRA10

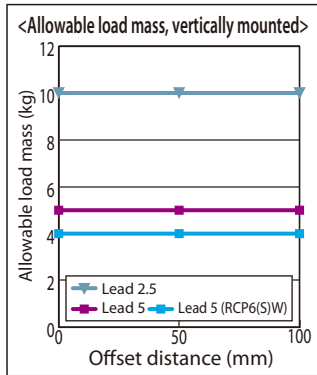

■ RCP6(S)-WRA12

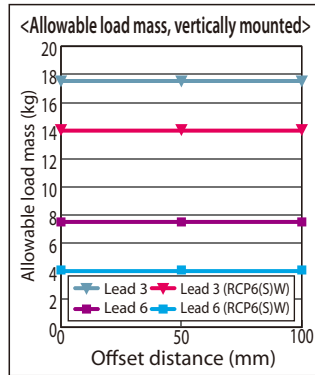

■ RCP6(S)-WRA14

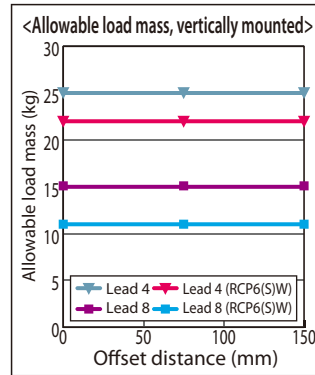

■ RCP6(S)-WRA16

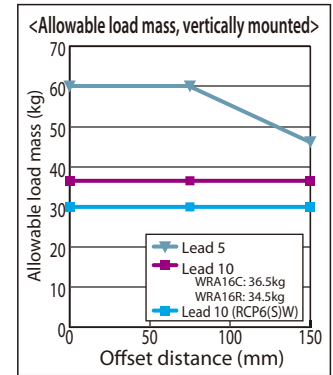

■ Allowable Load Mass for (Table type) RCP6(S)-TA Series

■ Due to the table type structure, longer stroke actuators result in lower allowable load mass.

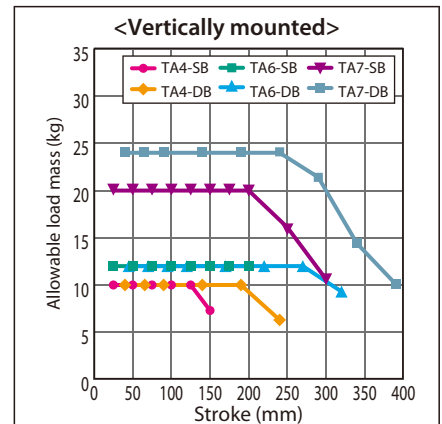
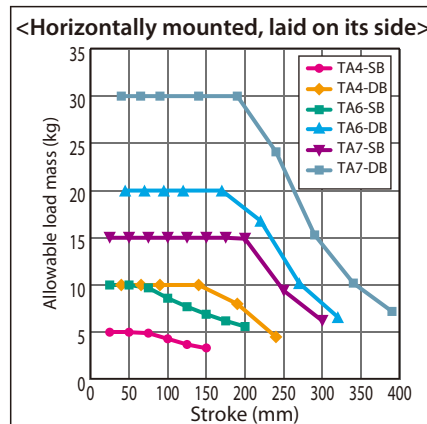
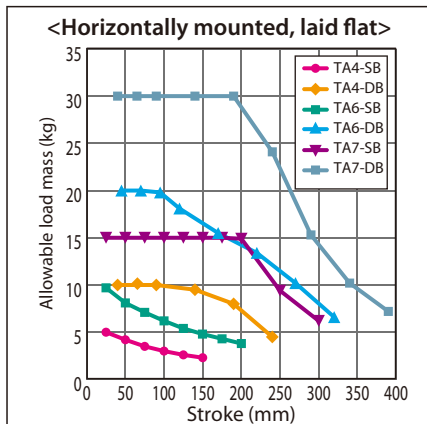

Allowable load calculation conditions: Load mass corresponding to a product service life of 5,000 km, considering moments generated by acceleration/deceleration. (Acceleration: 0.5G, speed: 500mm/s. *For WRA16 type, acceleration: 0.2G, speed: 500mm/s)

Duty Cycle

Duty cycle is the percentage of the actuator's active operation time in each cycle.

Please note that the way to calculate duty cycle for the stepper motor and AC servo motor types differs.

[Duty Cycle]

Duty cycle is the percentage of the actuator's active operation time in each cycle.

$$D = \frac{T_M}{T_M + T_R} \times 100(\%)$$

D: Duty
 T_M: Operating time
 (including push-motion
 operation)
 T_R: Stopping time

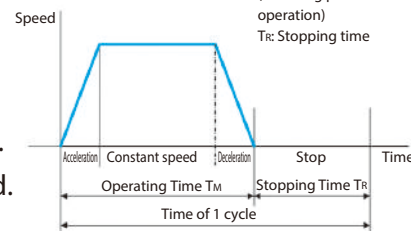

<Stepper motor>

For stepper motor type, an actuator can be operated at 100% of its duty cycle. RCP6SCR/RCP6SW is the model that requires the duty cycle to be limited.

For RCP6SCR/W

Duty Cycle by Models

RCP6S Series	Duty Cycle
□35 stepper motor type SA4/RRA4/RA4/TA4/WSA10/WRA10 (Common to coupled motor/side-mounted motor)	100%
□42 stepper motor type SA6/RRA6/RA6/TA6/WSA12/WRA12 (Common to coupled motor/side-mounted motor)	Please see the graph below.
□56 stepper motor type SA7/RRA7/RA7/TA7/WSA14/WRA14 (Common to coupled motor/side-mounted motor)	Please see the graph below.
□56 high thrust stepper motor type SA8/WSA16 (Common to coupled motor/side-mounted motor)	100%
□60 high thrust stepper motor type RRA8/RA8/WRA16 (Common to coupled motor/side-mounted motor)	70%

■ Correlation diagram of ambient temperature and duty cycle for 42 stepper motor type

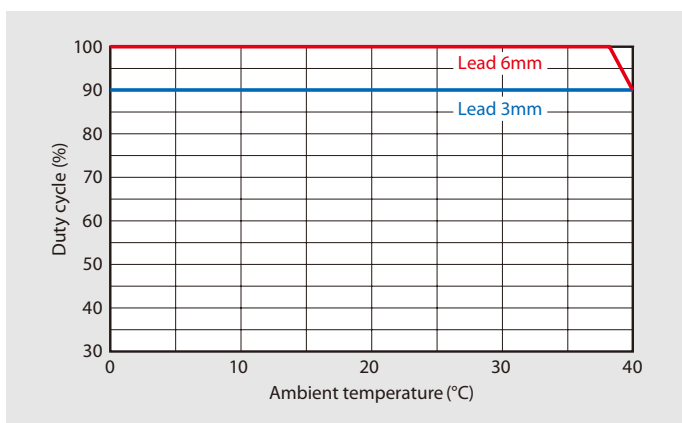

□42 stepper motor type

SA6/RRA6/RA6/TA6/WSA12/WRA12

(Common to coupled motor/side-mounted motor)

Lead	3mm	6mm	12mm/20mm
Duty Cycle Limit	90% or less	100% at 38°C or less 90% or less at 40°C	100%

* RCP6W does not have a 20mm lead.

■ Correlation diagram of ambient temperature and duty cycle for 56 stepper motor type (Excludes the high thrust motor)

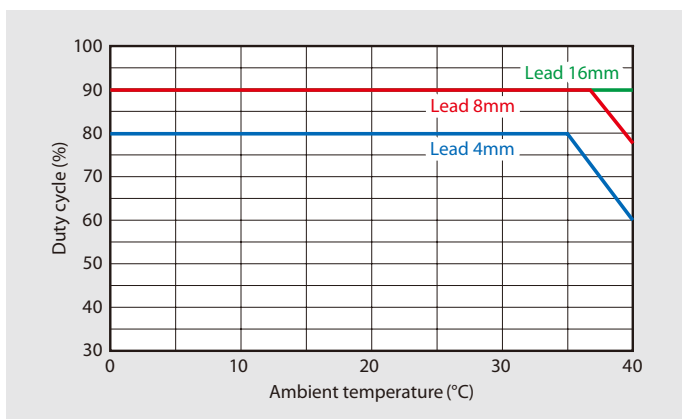

□56 stepper motor type

SA7/RRA7/RA7/TA7/WSA14/WRA14

(Common to coupled motor/side-mounted motor)

Lead	4mm	8mm	16mm	24mm
Duty Cycle Limit	80% at 35°C or less 60% or less at 40°C	90% at 37°C or less 78% or less at 40°C	90% or less	100%

* RCP6W does not have a 24mm lead.

Double Slider Selection Notes

Be sure to check the following specifications when selecting a double slider.

RCP6(S)(CR) Double Slider Specification

Series name	Type name	Lead (mm)	Allowable dynamic moment						Overhang load length (mm)	Cleanroom specification suction amount (Nℓ/min)	*1 Payload compensation A (kg)	*1 Payload compensation B (kg)	*1 Payload compensation speed (mm/s)	Slider length (mm)	Double slider minimum stroke (mm)
			Reference rated life (km)	Slider span (mm)		Ma direction (N-m)	Mb direction (N-m)	Mc direction (N-m)							
				Slider actual span	Slider cover span										
RCP6(S)	SA4C(R)	10	5000	60	24	44.6	63.6	15.7	420	-	0.6	2	350	76	150
		5											215		
		2.5											105		
	SA6C(R)	12	5000	90	40	106	152	40	630	-	1.2	2	320	110	200
		6											280		
		3											140		
	SA7C(R)	16	5000	70	20	285	285	145	810	-	1.7	5	280	130	200
		8											140		
		4											70		
	SA8C(R)	20	5000	120	35	565	565	237	1200	-	7 (*2)	-	-	165	250
		10											-		
		5											-		
RCP6(S)CR	SA4C	10	5000	60	24	44.6	63.6	15.7	420	-	0.6	2	60	76	150
		5											30		
		2.5											20		
	SA6C	12	5000	90	40	106	152	40	630	-	1.2	2	110	110	200
		6											60		
		3											35		
	SA7C	16	5000	70	20	285	285	145	810	-	1.7	5	100	130	200
		8											50		
		4											40		
	SA8C	20	5000	120	35	565	565	237	1200	-	7 (*2)	-	170	165	250
		10											90		
		5											40		

[List of Options Unavailable for Double Slider]

Series name	Type name	Lead (mm)	Double Slider Selection Not Possible	
			Horizontal mount	Vertical mount
RCP6(S)	SA4C(R)	16	×	×
		10	×	×
	SA6C(R)	20	×	×
		12	×	×
	SA7C(R)	24	×	×
16		×	×	
SA8C(R)	30	×	×	
	20	×	×	
RCP6(S)CR	SA4C	16	×	×
		10	×	×
	SA6C	20	×	×
		12	×	×
	SA7C	24	×	×
		16	×	×
SA8C	30	×	×	
	20	×	×	

[Double Slider Span Diagram]

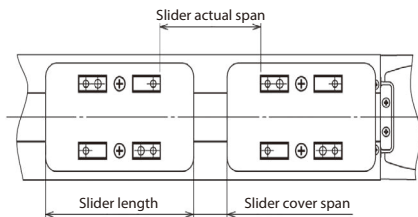

*1 Double slider specification (other than RCP6(CR)-SA8) values obtained by subtracting the payload compensation mass A from the standard specification payload are the payload specification values up to the payload compensation speed.

When operating at a speed exceeding the payload compensation speed, the value obtained by subtracting the payload compensation mass B from the standard specification payload is the payload specification value. Moreover, refer to the nominal stroke specification value for the maximum speed.

*2 RCP6(CR)-SA8 double slider specification values obtained by subtracting the payload compensation mass A from the standard specification payload are the payload specification values at the full speed range. Moreover, refer to the nominal stroke specification value for the maximum speed.

Notes: · Calculate the double slider load capacity using the specification table above and the "Payload by Speed /Acceleration Table" (P207~). Check the maximum speed from the calculated payload quantity. (Refer to the instruction manual for details.)

· The double slider cannot be selected in some cases depending on the lead. Check with the [List of Options Unavailable for Double Slider].

· When selecting the double slider specification and non-motor end specification at the same time, always check that the home return motion functions correctly after connecting the drive slider and the free slider.

RCP6W Exterior Component Material

■ RCP6W-RA4

Name		Material	Treatment	Finish	RA4C	RA4R
①	Body frame	Extruded aluminum	White alumite		○	○
②	Rod	Drawn aluminum	Hard alumite	Buffing finish	○	○
③	Rear bracket	Aluminum die cast	Designer coating		○	○
④	Motor bracket	Aluminum die cast	Designer coating		○	○
⑤	Motor cover	Extruded aluminum	White alumite		○	○
⑥	End cover	Aluminum die cast	Designer coating		○	○
⑦	Pulley cover	Stainless steel			○	○
⑧	Rod seal housing IP	Aluminum	White alumite		○	○
⑨	Tip bracket	Stainless steel			○	○
⑩	Cap	Stainless steel			○	○
⑪	Exterior bolts/screws	Stainless steel			○	○
⑫	Dust seal	Rubber (NBR)			○	○
⑬	Grease nipple	Brass (C3604)	Non-electrolytic metal plating		○	○
⑭	Intake/exhaust port	Resin (PBT, POM), brass nickel plated			○	○
⑮	Actuator cable					
	Cable gland	Rubber (NBR), resin (PBT), brass nickel plated			○	○
	Cable sheath	Vinyl chloride (PVC)			○	○
	Hex nut	Stainless steel			○	○
	Square nut	Stainless steel			○	○
	Gaskets	Rubber (NBR)			○	○

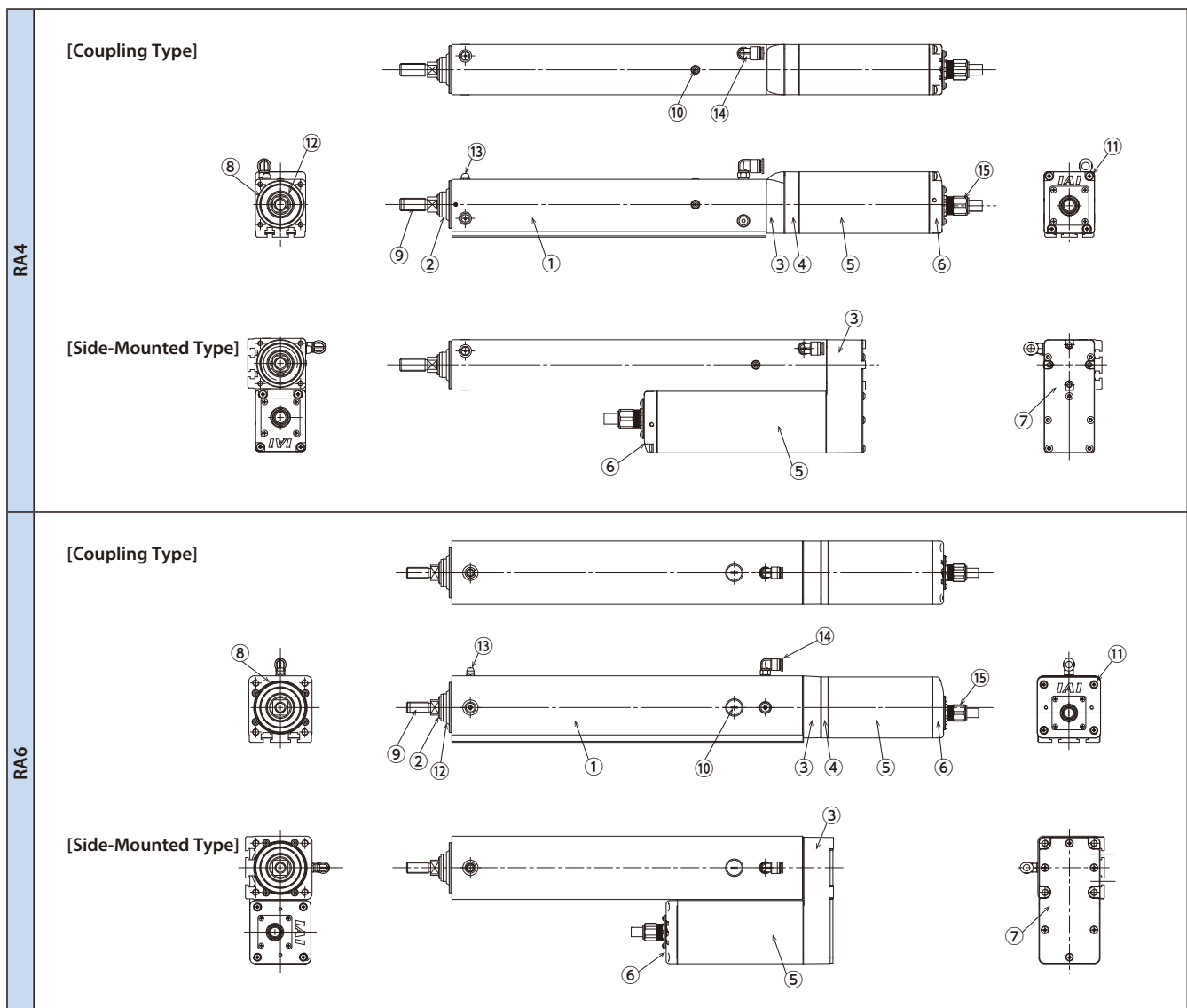

■ RCP6W-RA6/RA7/RA8

Name		Material	Treatment	Finish	RA6C	RA6R	RA7C	RA7R	RA8C	RA8R
Exterior Components	① Body frame	Extruded aluminum	White alumite		○	○	○	○	○	○
	② Rod	Drawn aluminum	Hard alumite	Buffing finish	○	○	○	○	○	○
	③ Rear bracket	Aluminum die cast	Designer coating		○	○	○	○	○	○
	④ Motor bracket	Aluminum die cast	Designer coating		○	○	○	○	○	○
	⑤ Motor cover	Extruded aluminum	White alumite		○	○	○	○	○	○
	⑥ End cover	Aluminum die cast	Designer coating		○	○	○	○	○	○
	⑦ Pulley cover	Stainless steel			○	○	○	○	○	○
	⑧ Rod seal housing IP	Aluminum	White alumite		○	○	○	○	○	○
	⑨ Tip bracket	Stainless steel			○	○	○	○	○	○
	⑩ Cap	Rubber (NBR)			○	○	○	○	○	○
	⑪ Exterior bolts/screws	Stainless steel			○	○	○	○	○	○
	⑫ Dust seal	Rubber (NBR)			○	○	○	○	○	○
	⑬ Grease nipple	Brass (C3604)	Non-electrolytic metal plating		○	○	○	○	○	○
	⑭ Intake/exhaust port	Resin (PBT, POM), brass nickel plated			○	○	○	○	○	○
⑮ Actuator cable	Cable gland	Rubber (NBR), resin (PBT), brass nickel plated			○	○	○	○	○	○
	Cable sheath	Vinyl chloride (PVC)			○	○	○	○	○	○
Hex nut		Stainless steel			○	○	○	○	○	○
Square nut		Stainless steel			○	○	○	○	○	○
Gaskets		Rubber (NBR)			○	○	○	○	○	○

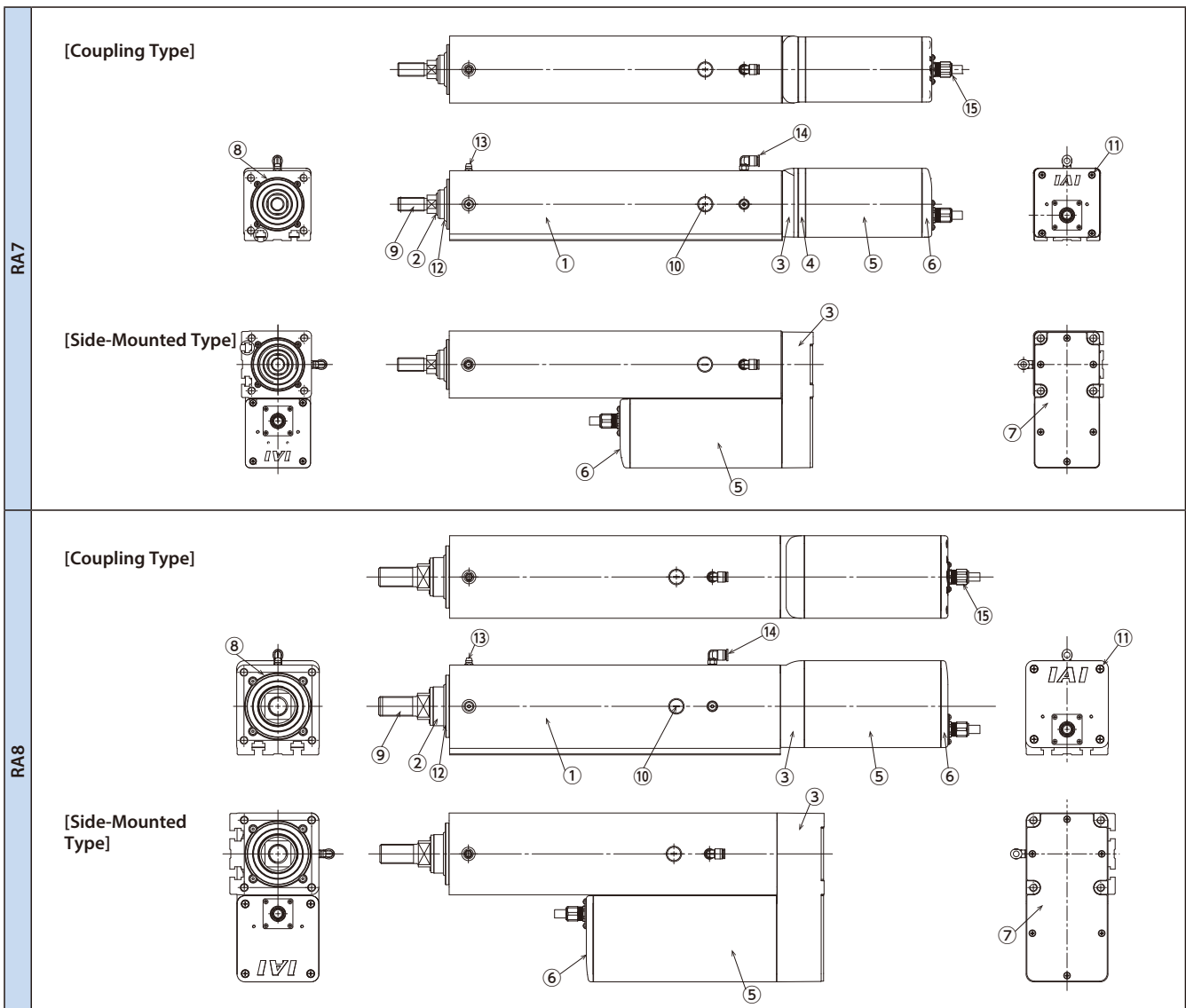

Foreword
Slider Type
Wide Slider Type
Rod Type
Radial Cylinder
Wide Radial Cylinder
Table Type
Cleanroom Slider
Cleanroom Wide Slider
Dust/Splash-Proof Rod
Dust/Splash-Proof Radial Cylinder
Dust/Splash-Proof Wide Radial Cylinder
Options
Reference Data
Controller

RCP6W Exterior Component Material

■ RCP6W-RAA4/RAA6/RAA7

Name		Material	Treatment	Finish	RRA4C	RRA4R	RRA6C	RRA6R	RRA7C	RRA7R
①	Frame	Extruded aluminum	White alumite		○	○	○	○	○	○
②	Rod	Drawn aluminum	Hard alumite	Buffing finish	○	○	○	○	○	○
③	Rear bracket	Aluminum die cast	Designer coating		○	○	○	○	○	○
④	Motor bracket	Aluminum die cast	Designer coating		○	○	○	○	○	○
⑤	Reverse bracket	Aluminum die cast	Designer coating		○	○	○	○	○	○
⑥	Motor cover	Extruded aluminum	White alumite		○	○	○	○	○	○
⑦	End cover	Aluminum die cast	Designer coating		○	○	○	○	○	○
⑧	Pulley cover	Stainless steel			○	○	○	○	○	○
⑨	Front bracket IP	Aluminum	White alumite		○	○	○	○	○	○
⑩	Rod tip bracket	Stainless steel			○	○	○	○	○	○
⑪	Hole cap (grease nipple)	Rubber (NBR)			○	○	○	○	○	○
⑫	Dust seal	Rubber (NBR)			○	○	○	○	○	○
⑬	Grease nipple	Brass (C3604)	Non-electrolytic metal plating		○	○	○	○	○	○
⑭	Intake/exhaust port	Resin (PBT, POM), brass nickel plated			○	○	○	○	○	○
⑮	Actuator cable	Cable gland Rubber (NBR), resin (PBT), brass nickel plated			○	○	○	○	○	○
		Cable sheath Vinyl chloride (PVC)			○	○	○	○	○	○
Exterior bolts/screws		Stainless steel			○	○	○	○	○	○
Hex nut		Stainless steel			○	○	○	○	○	○
Square nut		Stainless steel			○	○	○	○	○	○
Gaskets		Rubber (NBR)			○	○	○	○	○	○

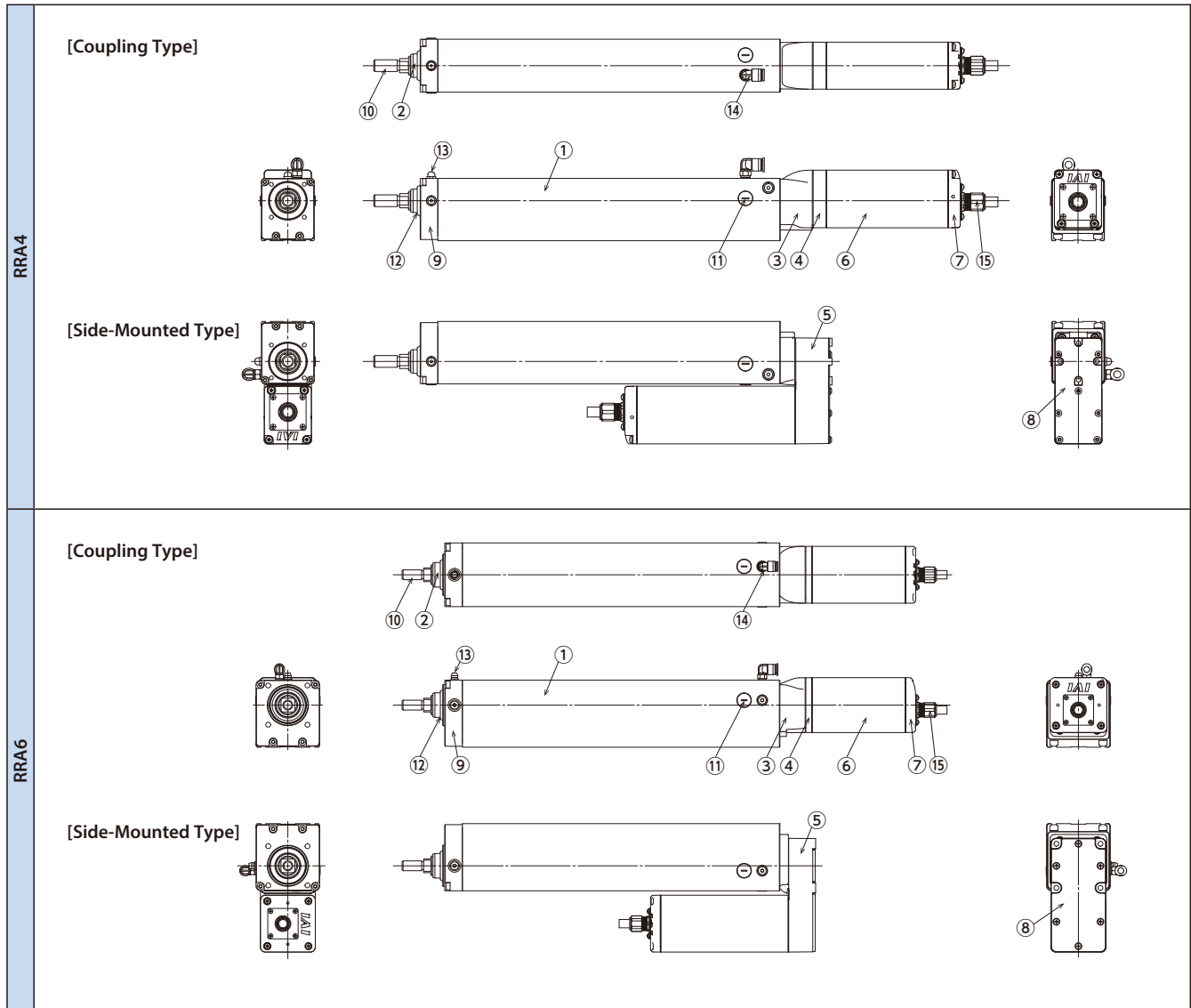

■ RCP6W-RRA8

Name		Material	Treatment	Finish	RRA8C	RRA8R
Exterior Components	① Frame	Extruded aluminum	White alumite		○	○
	② Rod	Drawn aluminum	Hard alumite	Buffing finish	○	○
	③ Base	Extruded aluminum	White alumite		○	○
	④ Rear bracket	Aluminum die cast	Designer coating		○	○
	⑤ Reverse bracket	Aluminum die cast	Designer coating		○	○
	⑥ Motor cover	Extruded aluminum	White alumite		○	○
	⑦ End cover	Aluminum die cast	Designer coating		○	○
	⑧ Pulley cover	Stainless steel			○	○
	⑨ Front bracket IP	Aluminum die cast	Designer coating		○	○
	⑩ Rod tip bracket	Stainless steel			○	○
	⑪ Hole cap (grease nipple)	Rubber (NBR)			○	○
	⑫ Dust seal	Rubber (NBR)			○	○
	⑬ Grease nipple	Brass (C3604)	Non-electrolytic metal plating		○	○
	⑭ Intake/exhaust port	Resin (PBT, POM), brass nickel plated			○	○
	⑮ Actuator cable	Cable gland	Rubber (NBR), resin (PBT), brass nickel plated			○
Cable sheath		Vinyl chloride (PVC)			○	○
Exterior bolts/screws		Stainless steel			○	○
Hex nut		Stainless steel			○	○
Gaskets		Rubber (NBR)			○	○

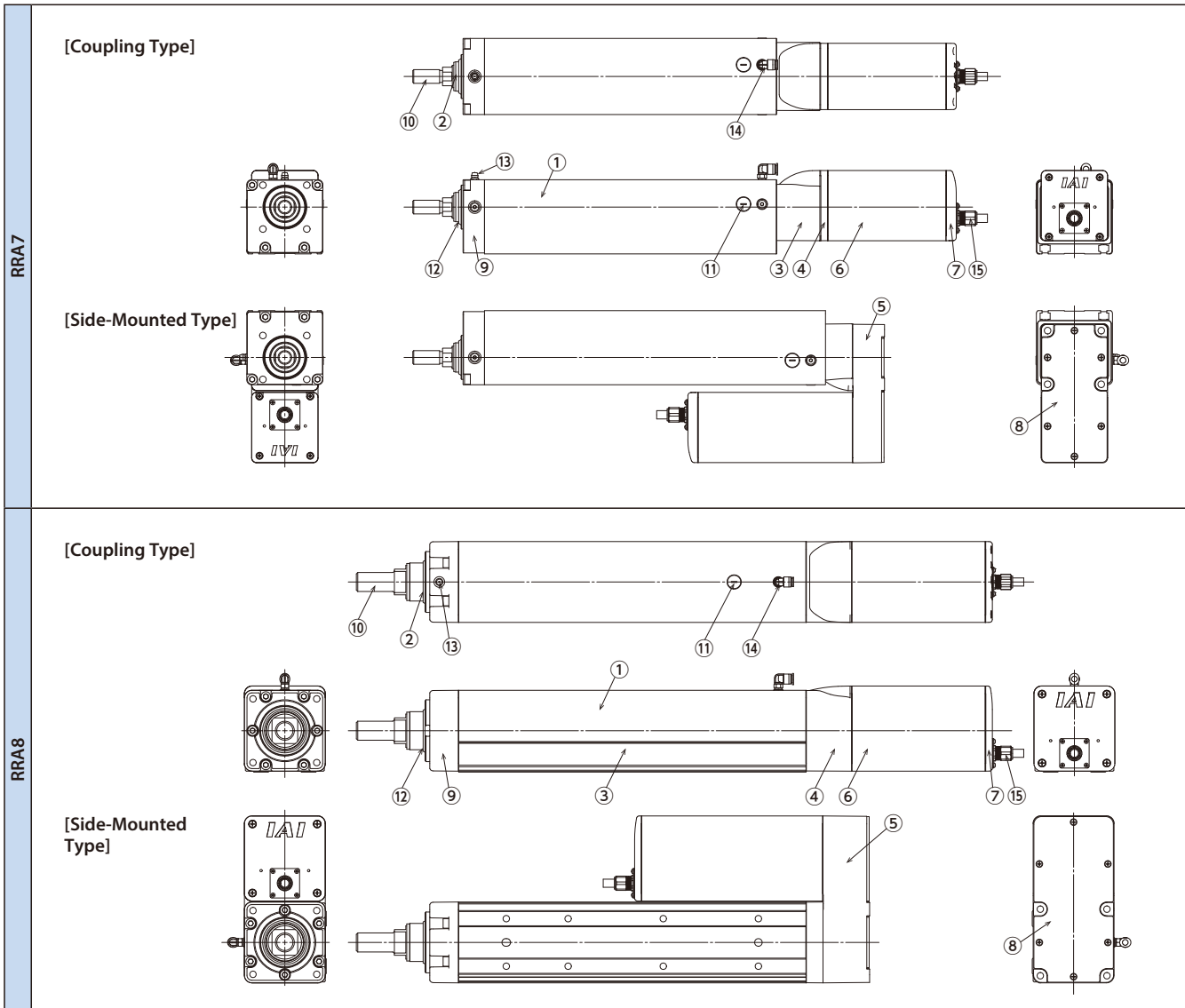

Foreword
Slider Type
Wide Slider Type
Rod Type
Radial Cylinder
Wide Radial Cylinder
Table Type
Cleanroom Slider
Cleanroom Wide Slider
Dust/Splash-Proof Rod
Dust/Splash-Proof Radial Cylinder
Dust/Splash-Proof Wide Radial Cylinder
Options
Reference Data
Controller

RCP6W Exterior Component Material

■ RCP6W-WRA10

Name		Material	Treatment	Finish	WRA10C	WRA10R
①	Base	Extruded aluminum	White alumite		○	○
②	Frame cover	Extruded aluminum	White alumite		○	○
③	Rod	Stainless steel tube	Hard chrome plating	Buffing finish	○	○
④	Tip bracket	Stainless steel			○	○
⑤	Locking nut	Stainless steel			○	○
⑥	Front bracket	Aluminum die cast	Designer coating		○	○
⑦	Rear bracket	Aluminum die cast	Designer coating		○	○
⑧	Motor bracket	Aluminum die cast	Designer coating		○	○
⑨	Motor cover	Extruded aluminum	White alumite		○	○
⑩	End cover	Aluminum die cast	Designer coating		○	○
⑪	Reverse bracket	Aluminum die cast	Designer coating		○	○
⑫	Pulley cover	Stainless steel			○	○
⑬	Cap	Rubber (NBR)			○	○
⑭	Frame cover	Aluminum	White alumite		○	○
⑮	Dust seal	Rubber (NBR)			○	○
⑯	Dust seal housing	Aluminum	White alumite		○	○
⑰	Grease nipple	Brass (C3604)	Non-electrolytic metal plating		○	○
⑱	Intake/exhaust port	Resin (PBT), brass nickel plated			○	○
⑲	Actuator cable Cable gland	Rubber (NBR), resin (PBT), brass nickel plated			○	○
	Cable sheath	Vinyl chloride (PVC)			○	○
Exterior bolts/screws		Stainless steel			○	○
Gaskets		Rubber (NBR)			○	○

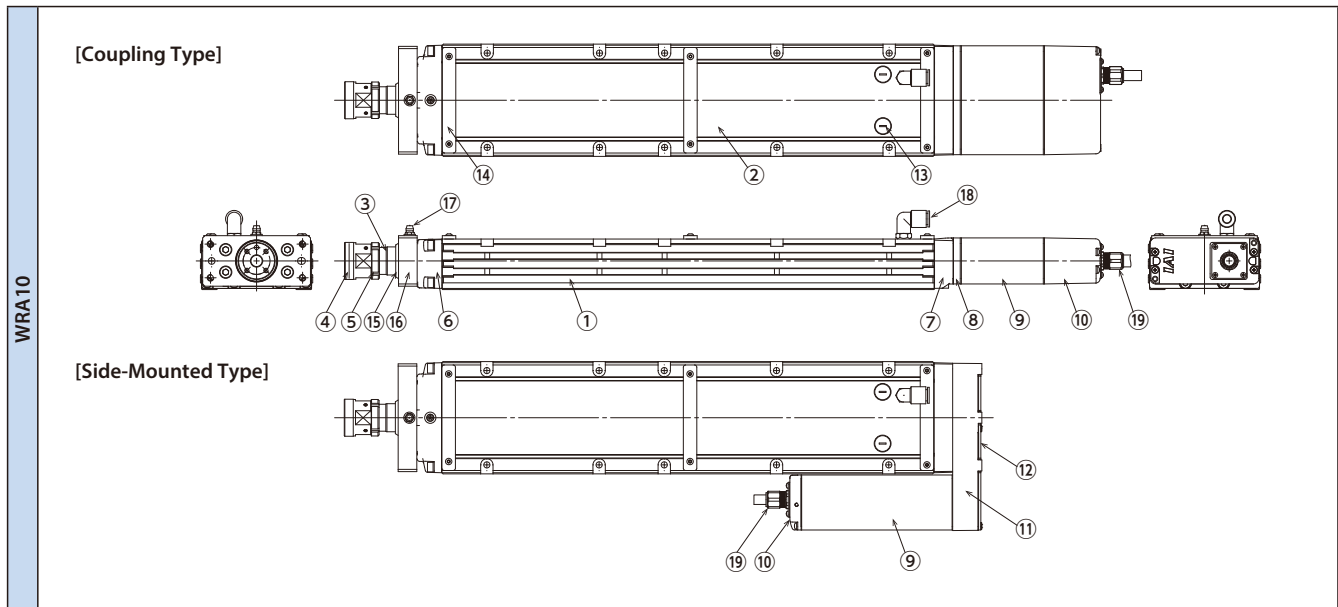

■ RCP6W-WRA12/WRA14/WRA16

Name		Material	Treatment	Finish	WRA12C	WRA12R	WRA14C	WRA14R	WRA16C	WRA16R
Exterior Components	① Base	Extruded aluminum	White alumite		○	○	○	○	○	○
	② Frame cover	Extruded aluminum	White alumite		○	○	○	○	○	○
	③ Rod	Stainless steel tube	Hard chrome plating	Buffing finish	○	○	○	○	○	○
	④ Tip bracket	Stainless steel			○	○	○	○	○	○
	⑤ Locking nut	Stainless steel			○	○	○	○	○	○
	⑥ Front bracket	Aluminum die cast	Designer coating		○	○	○	○	○	○
	⑦ Rear bracket	Aluminum die cast	Designer coating		○	○	○	○	○	○
	⑧ Motor bracket	Aluminum die cast	Designer coating		○	○	○	○	○	○
	⑨ Motor cover	Extruded aluminum	White alumite		○	○	○	○	○	○
	⑩ Motor end cover (Coupling)	Aluminum die cast	Designer coating		○	○	○	○	○	○
	⑪ Reverse bracket	Aluminum die cast	Designer coating		○	○	○	○	○	○
	⑫ Pulley cover	Stainless steel			○	○	○	○	○	○
	⑬ Motor end cover (Side-mounted)	Aluminum	White alumite		○	○	○	○	○	○
	⑭ Cap	Rubber (NBR)			○	○	○	○	○	○
	⑮ Frame cover retainer	Aluminum	White alumite		○	○	○	○	○	○
	⑯ Dust seal	Rubber (NBR)			○	○	○	○	○	○
	⑰ Dust seal housing	Aluminum	White alumite		○	○	○	○	○	○
	⑱ Grease nipple	Brass (C3604)	Non-electrolytic metal plating		○	○	○	○	○	○
	⑲ Intake/exhaust port	Resin (PBT), brass nickel plated			○	○	○	○	○	○
	⑳ Actuator cable length	Cable gland	Rubber (NBR), resin (PBT), brass nickel plated		○	○	○	○	○	○
Cable sheath		Vinyl chloride (PVC)		○	○	○	○	○	○	
Exterior bolts/screws		Stainless steel		○	○	○	○	○	○	
Gaskets		Rubber (NBR)		○	○	○	○	○	○	

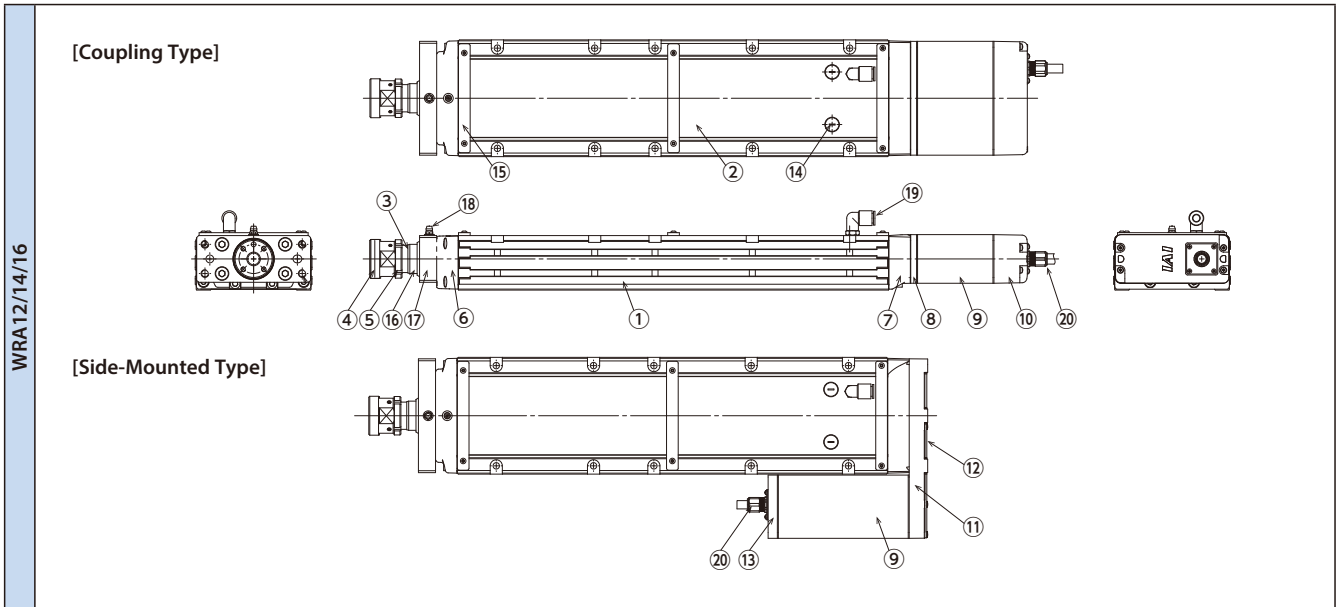

Foreword
Slider Type
Wide Slider Type
Rod Type
Radial Cylinder
Wide Radial Cylinder
Table Type
Cleanroom Slider
Cleanroom Wide Slider
Dust/Splash-Proof Rod
Dust/Splash-Proof Radial Cylinder*
Dust/Splash-Proof Wide Radial Cylinder
Options
Reference Data
Controller

PCON-CB/CFB



Position Controller for RCP6/RCP5/
RCP4 (PowerCON Applicable) /RCP3/RCP2

Features

1 High-resolution battery-less absolute encoder compatible

The RCP6 equipped with a high-resolution battery-less absolute encoder is supported. Since no battery is needed to retain position data, less space is required in the control panel, which in turn leads to lower cost of your equipment. The resolution is increased from 800 pulses /rev to 8,192 pulses/rev.



2 PowerCON Equipped

PowerCON (high-output driver) which can enable the stepper motor to perform at its maximum capacity is now installed. By using PowerCON, the output of the stepper motor is increased by 50%. It contributes to cycle time reduction and productivity improvement.

3 Collision Detection Function Equipped

This function stops the operation immediately when the actuator comes into contact with an object. The actuator stops without crashing, so that damage to the actuator can be minimized.

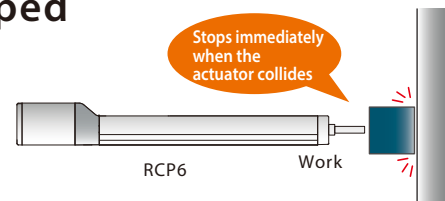

4 Enhanced Monitor Functions

The PC compatible software can display information about the actuator and controller in operation as waveforms.

*Information that can be displayed: Command current value, current speed/position, and PIO signals (start, positioning completion, alarm, etc.)

Using the trigger function, the end user can specify a particular moment, either a change in PIO signals or a designated moment during the actuator's operation time, to begin displaying the waveforms.

Monitor function screen (example)

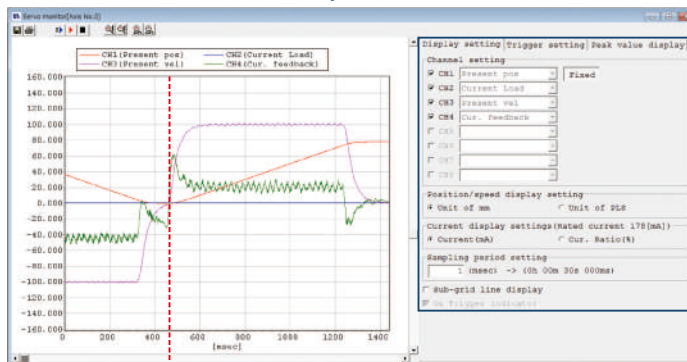

Signal: CSTR (start) turned ON

Display settings

Channel setting: CH1 Present pos, CH2 Current Load, CH3 Present vel, CH4 Cur. Feedback

Position/speed display setting: Unit of mm, Unit of deg

Current display settings (Rated current 170mA): Current (mA), Cur. Ratio (%)

Sampling period setting: 1 msec -> 0.01 0.05 0.1 0.5 1 5 10 50 100ms

Sub-grid line display: On (1/2 lines (default))

Trigger settings

Trigger setting: CH1 Present pos, CH2 Current Load, CH3 Present vel, CH4 Cur. Feedback











Trigger Type: Active edge(s)

Trigger release: Off

Wave must be before trigger setting: On

* Data acquiring starts from time of change of selected items.

* Items to be monitored can be selected.

Model number		PCON-CB/CGB, CFB/CGFB										
External view												
I/O type	Positioner type	Pulse-train type	Field network type									
												
I/O type model number		NP/PN	PLN/PLP	DV	CC	PR	CN	ML	ML3	EC	EP	PRT
PCON-CB/CGB	Battery-less absolute specification	○	○	○	○	○	○	○	○	○	○	○
	Simple absolute spec.	With absolute battery	○	-	○	○	○	○	○	○	○	○
		Without absolute battery	○	-	○	○	○	○	○	○	○	○
PCON-CFB/CGFB	Battery-less absolute specification	○	○	○	○	○	○	○	○	○	○	

*1 MECHATROLINK I/II is treated as an Intelligent I/O and supports only asynchronous commands. MECHATROLINK III is compatible with standard servo profiles.

Model Specification Items

<Controller>

PCON

Series	Type	Motor Type	Encoder Type	I/O Type	I/O Cable Length	Power Supply Voltage	Simple Absolute Specification	Controller Mounting Specification
CB	Standard	WAI Battery-less absolute specification Incremental specification	SA Simple absolute specification	NP PIO (NPN)	0 No cable	0 24VDC	(Blank) Battery-less absolute specification Incremental specification	(Blank) Screw mounting specification
CGB	Safety category compliant type							
CFB	56SP/60P/86P motor-compatible type	ML MECHATROLINK-I/II	ML3 MECHATROLINK III	PLN Pulse train (NPN)	2 2m	AB Simple absolute specification (With absolute battery. No battery unit included)	ABUN Simple absolute specification (Without absolute battery and battery unit)	DN DIN rail mounting specification
CGFB	Safety category compliant, 56SP/60P/86P motor-compliant type							
		PN PIO (PNP)		PLP Pulse train (PNP)	3 3m			
		DV DeviceNet			5 5m			
		CC CC-Link			* When a field network specification is selected, the I/O cable length is "0".			
		PR PROFIBUS-DP						
		CN CompoNet						
		EC EtherCAT						
		EP EtherNet/IP						
		PRT PROFINET IO						

(E.g.) 20P: 20□ 42SP: 42□

Note
In principle, the same type of motor as the type of motor of the actuator to be connected should be entered, but there are some models where the motor type of some controllers and actuators do not match. Be sure to check the corresponding models listed below during selection.
<285P target actuator>
● Controller motor type *285P*
RCP2-RA3C

* PCON-CFB/CGFB does not support a simple absolute specification.

* The mounting type (screw or DIN rail) of the absolute battery unit and the controller must be the same.

Foreword
Slider Type
Wide Slider Type
Rod Type
Radial Cylinder
Wide Radial Cylinder
Table Type
Cleanroom Slider
Cleanroom Wide Slider
Dust/Splash-Proof Rod
Dust/Splash-Proof Radial Cylinder*
Dust/Splash-Proof Wide Radial Cylinder
Options
Reference Data
Controller

■ PowerCON150 <PCON-CB/CGB>

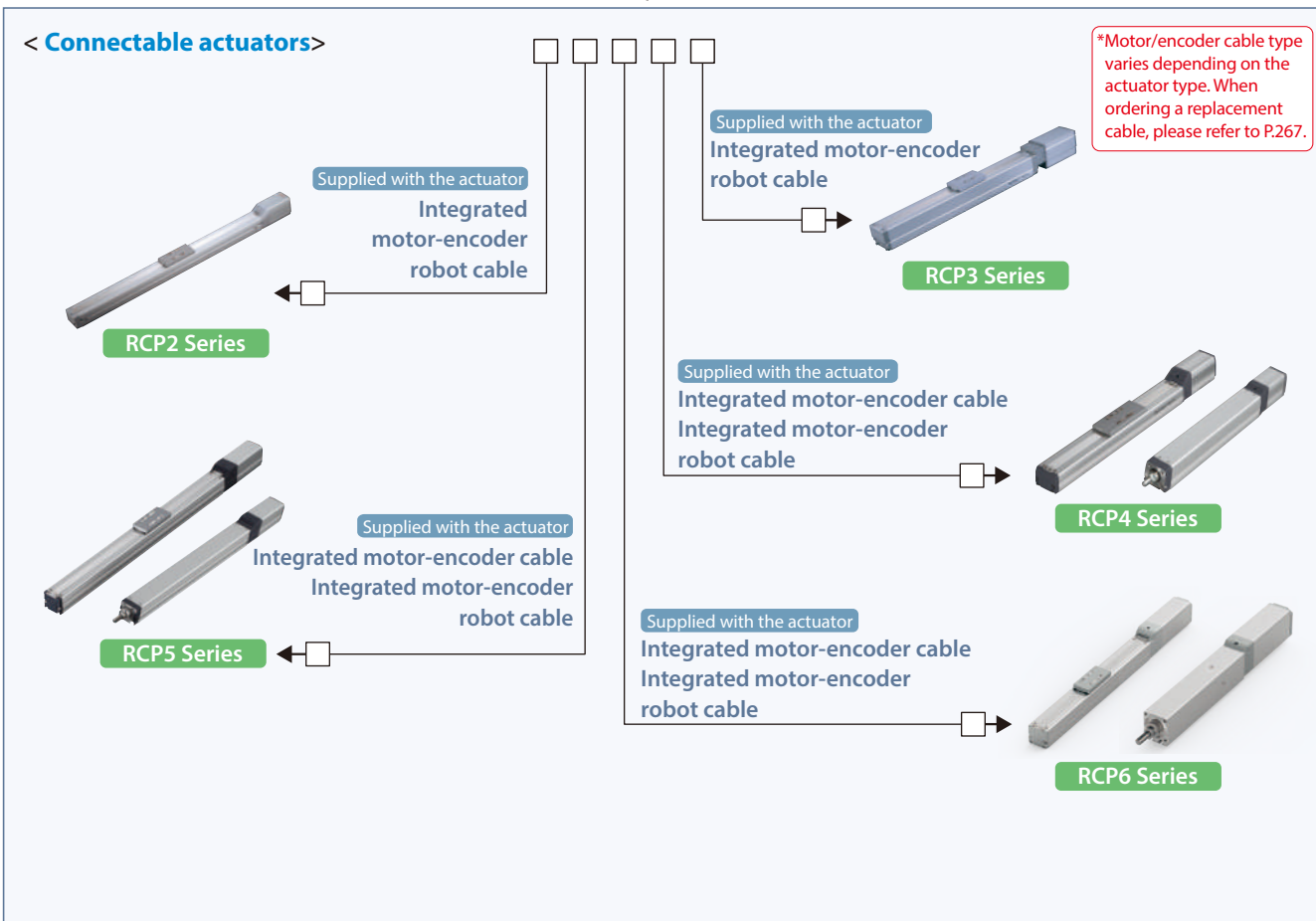
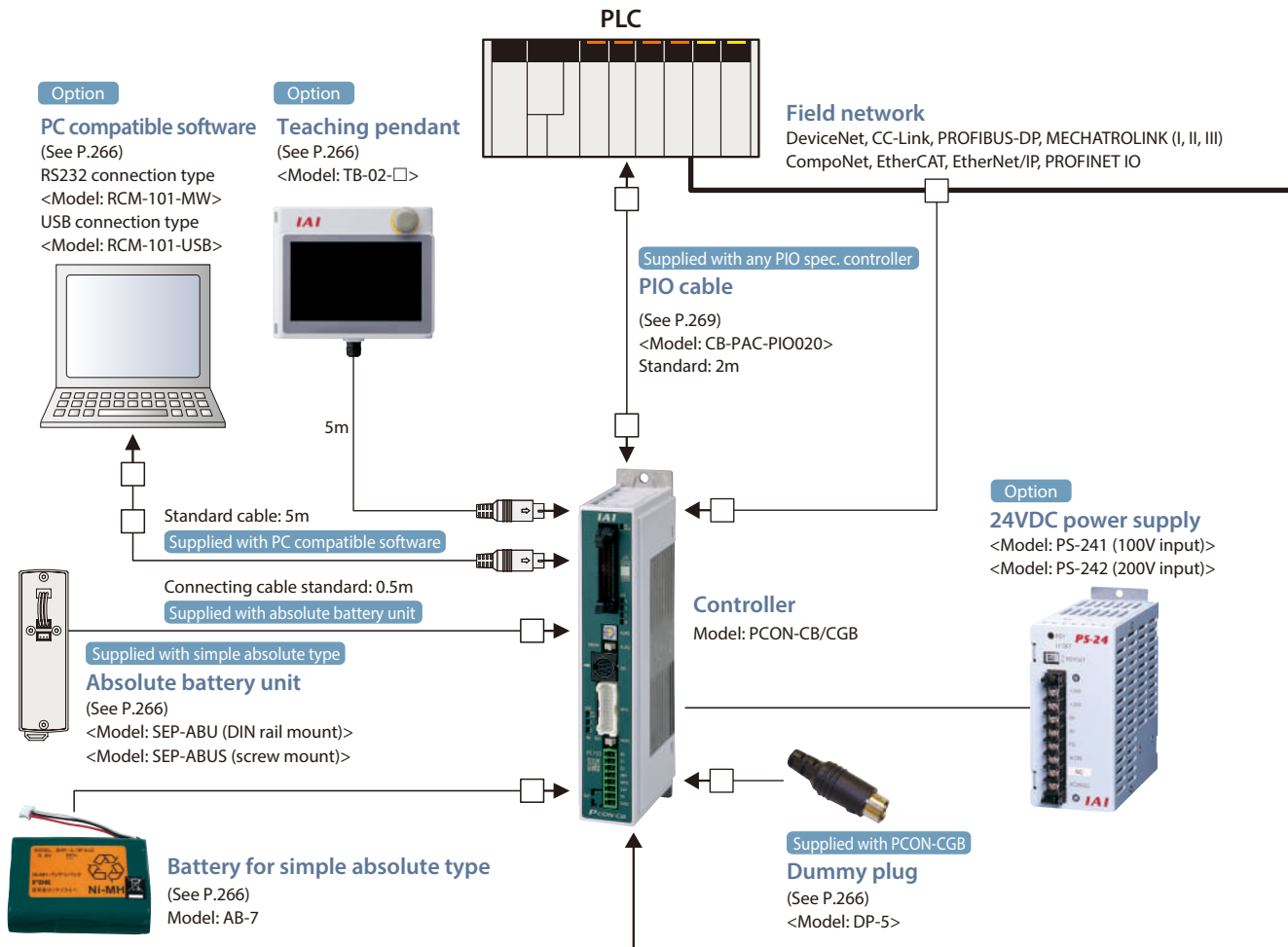

Foreword
Slider Type
Wide Slider Type
Rod Type
Radial Cylinder
Wide Radial Cylinder
Table Type
Cleanroom Slider
Cleanroom Wide Slider
Dust/Splash-Proof Rod
Dust/Splash-Proof Radial Cylinder
Dust/Splash-Proof Wide Radial Cylinder
Options
Reference Data
Controller

■ 56SP/60P/86P Motor Compatible <PCON-CFB/CGFB>

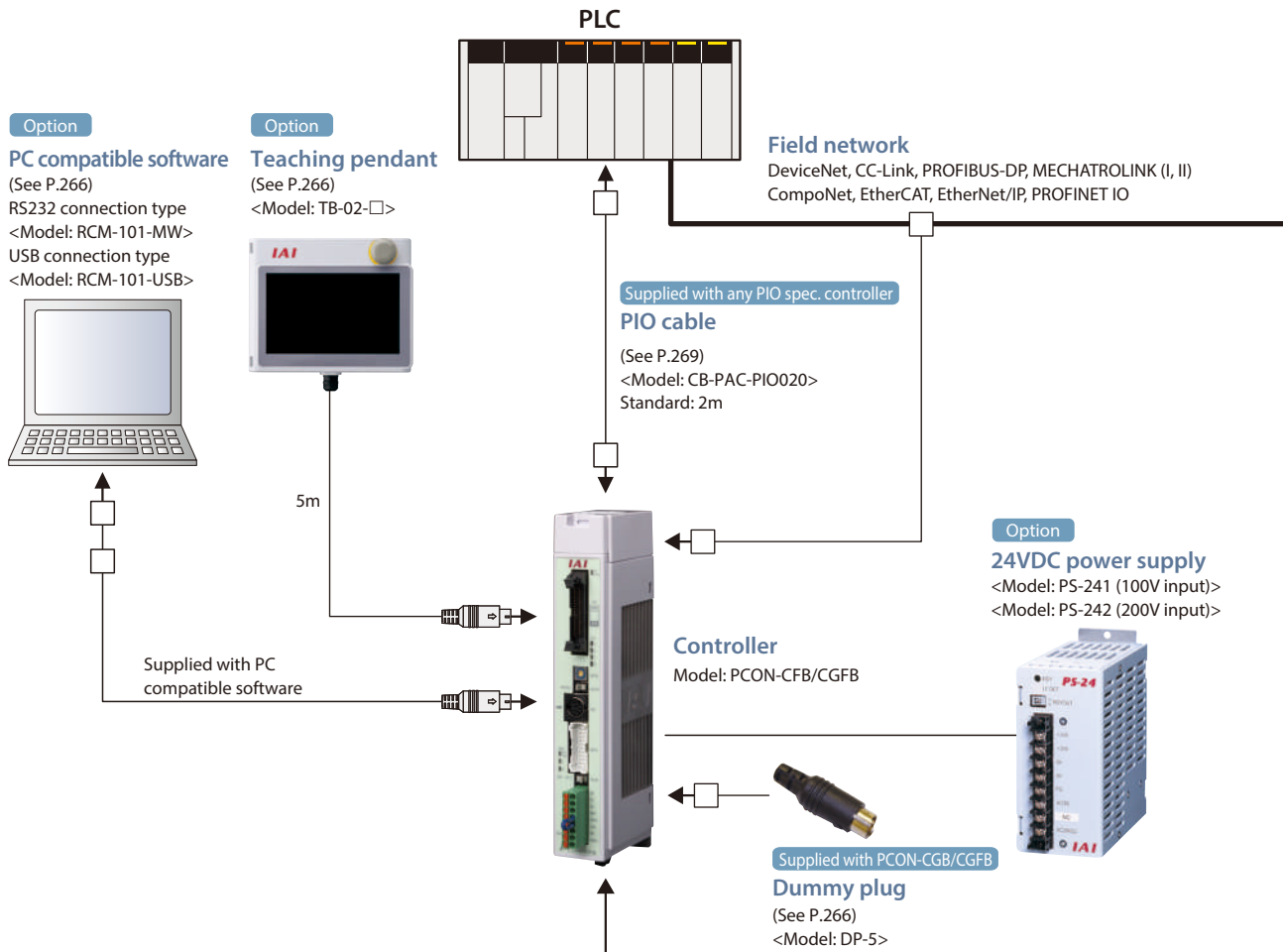

< Connectable actuators >

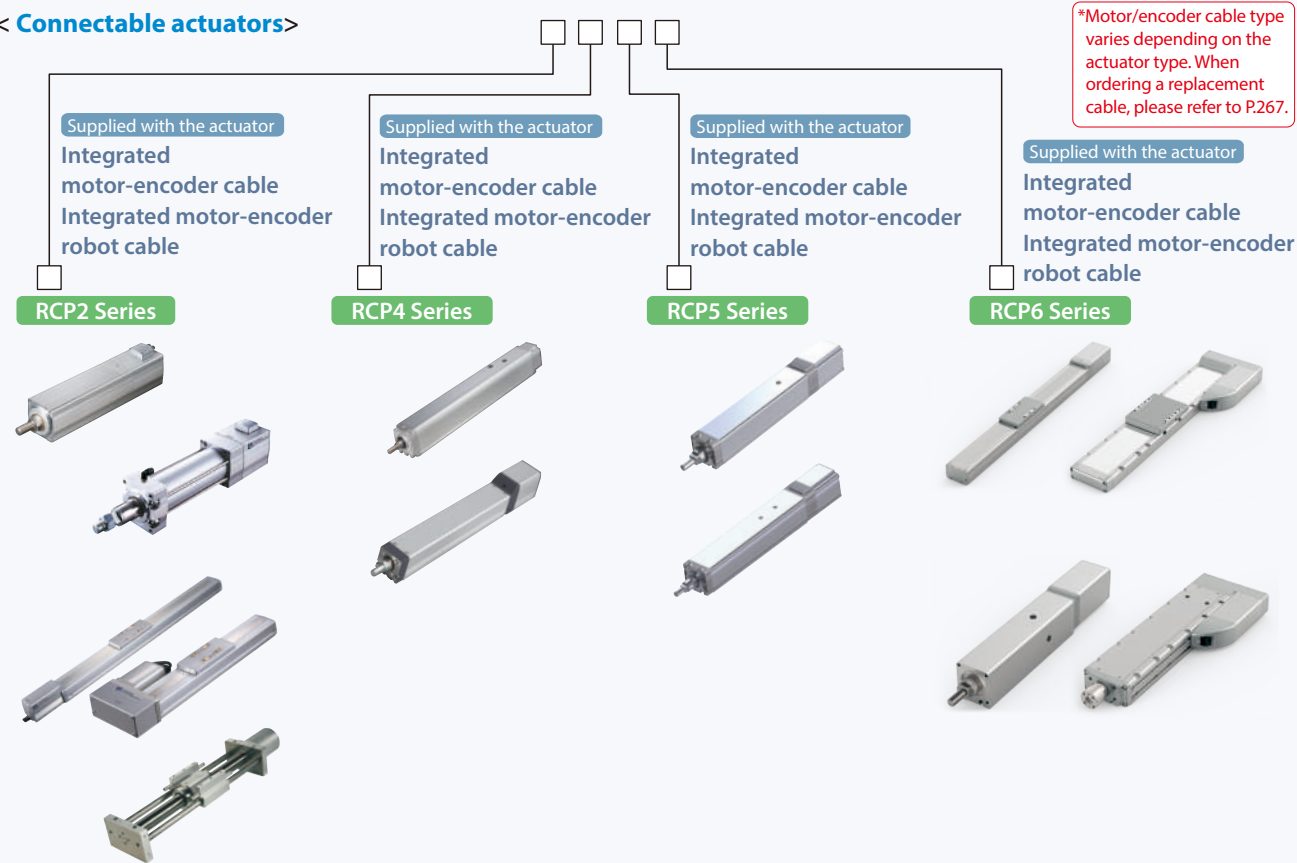

Foreword
Slider Type
Wide Slider Type
Rod Type
Radial Cylinder
Wide Radial Cylinder
Table Type
Cleanroom Slider
Cleanroom Wide Slider
Dust/Splash-Proof Rod
Dust/Splash-Proof Radial Cylinder
Dust/Splash-Proof Wide Radial Cylinder
Options
Reference Data
Controller

Input part External input specification

Item	Specification
Input voltage	24VDC ±10%
Input current	5mA, 1 circuit
ON/OFF voltage	ON voltage, 18VDC min. OFF voltage, 6VDC max.

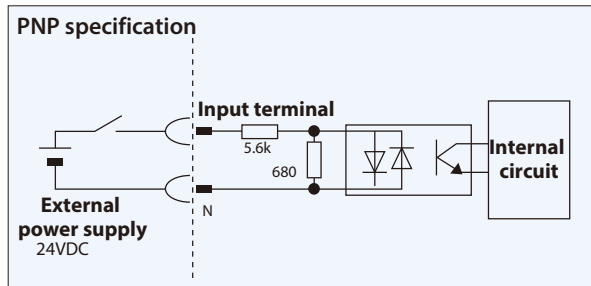
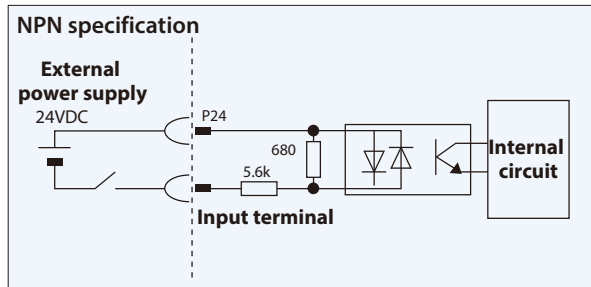

Output part External output specification

Item	Specification
Load voltage	24VDC
Maximum load current	50mA, 1 circuit
Leak current	2mA max. /point

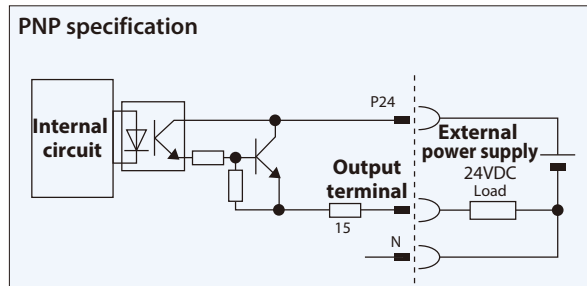
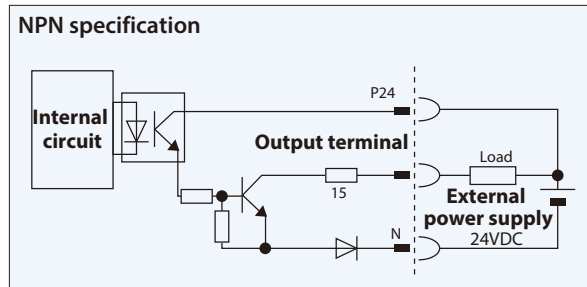

Types of PIO Patterns (Control Patterns)

This controller has eight different control methods.

Please select the PIO pattern that best suits your application in Parameter No.25, "PIO Pattern Selection".

Type	Set value of parameter No.25	Mode	Overview
PIO Pattern 0	0 (Factory setting)	Positioning mode (Standard type)	<ul style="list-style-type: none"> Number of positioning points: 64 points Position number command: Binary Coded Decimal (BCD) Zone signal output^{*1}: 1 point Position zone signal output^{*2}: 1 point
PIO Pattern 1	1	Teaching mode (Teaching type)	<ul style="list-style-type: none"> Number of positioning points: 64 points Position number command: Binary Coded Decimal (BCD) Position zone signal output^{*2}: 1 point Jog (inching) operation using PIO signals is supported. Current position data can be written to the position table using PIO signals.
PIO Pattern 2	2	256-point mode (256 positioning points)	<ul style="list-style-type: none"> Number of positioning points: 256 points Position number command: Binary Coded Decimal (BCD) Position zone signal output^{*2}: 1 point
PIO Pattern 3	3	512-point mode (512 positioning points)	<ul style="list-style-type: none"> Number of positioning points: 512 points Position number command: Binary Coded Decimal (BCD) No zone signal output
PIO Pattern 4	4	Solenoid valve mode 1 (7-point type)	<ul style="list-style-type: none"> Number of positioning points: 7 points Zone signal output^{*1}: 1 point Position number command: Individual number signal ON Position zone signal output^{*2}: 1 point
PIO Pattern 5	5	Solenoid valve mode 2 (3-point type)	<ul style="list-style-type: none"> Number of positioning points: 3 points Position number command: Individual number signal ON Completion signal: A signal equivalent to a LS (limit switch) signal can be output. Zone signal output^{*1}: 1 point Position zone signal output^{*2}: 1 point
PIO Pattern 6 (Note 1)	6	Pulse-train control mode for incremental	<ul style="list-style-type: none"> Differential pulse input (200 kpps max.) Home return function Zone signal output^{*1}: 2 points No feedback pulse output
PIO Pattern 7 (Note 1)	7	Pulse-train control mode for absolute	<ul style="list-style-type: none"> Reference point setting (1 point) Home return function Differential pulse input (200 kpps max.) No feedback pulse output Zone signal output^{*1}: 2 points

*1 Zone signal output: Please set the desired zone range in Parameter No.1/2 or 23/24, and it will remain effective once home return is completed.

*2 Position zone signal output: This command function relates to the position number. Set the desired zone range in the position table, and this function will only become enabled when the corresponding position is specified; it will be disabled for all other position commands.

(Note 1) Pulse train control mode is available only the pulse train control type is specified (PCON-CB-PLN and PLP) at the time of purchase.

Foreword
 Slider Type
 Wide Slider Type
 Rod Type
 Radial Cylinder
 Wide Radial Cylinder
 Table Type
 Cleanroom Slider
 Cleanroom Wide Slider
 Dust/Splash-Proof Rod
 Dust/Splash-Proof Radial Cylinder
 Dust/Splash-Proof Wide Radial Cylinder
 Options
 Reference Data
 Controller

The table below lists the signal assignments for the I/O flat cable under different PIO patterns. Connect an external device (such as a PLC) according to this table.

Pin No.	Category	PIO function	Parameter No.25, "PIO Pattern Selection"					
			0	1	2	3	4	5
			Positioning mode	Teaching mode	256-point mode	512-point mode	Solenoid valve mode 1	Solenoid valve mode 2
	Input	Number of positioning points	64 points	64 points	256 points	512 points	7 points	3 points
		Home return signal	○	○	○	○	○	×
		Jog signal	×	○	×	×	×	×
		Teaching signal (writing of current position)	×	○	×	×	×	×
	Output	Brake release	○	×	○	○	○	○
		Moving signal	○	○	×	×	×	×
		Zone signal	○	△ (Note 1)	△ (Note 1)	×	○	○
		Position zone signal	○	○	○	×	○	
1A	24V	P24						
2A	24V	P24						
3A	Pulse Input	-						
4A		-						
5A	Input	IN0	PC1	PC1	PC1	PC1	ST0	ST0
6A		IN1	PC2	PC2	PC2	PC2	ST1	ST1(JOG+)
7A		IN2	PC4	PC4	PC4	PC4	ST2	ST2 (Non-Functional)
8A		IN3	PC8	PC8	PC8	PC8	ST3	-
9A		IN4	PC16	PC16	PC16	PC16	ST4	-
10A		IN5	PC32	PC32	PC32	PC32	ST5	-
11A		IN6	-	MODE	PC64	PC64	ST6	-
12A		IN7	-	JISL	PC128	PC128	-	-
13A		IN8	-	JOG+	-	PC256	-	-
14A		IN9	BKRL	JOG-	BKRL	BKRL	BKRL	BKRL
15A		IN10	RMOD	RMOD	RMOD	RMOD	RMOD	RMOD
16A		IN11	HOME	HOME	HOME	HOME	HOME	-
17A		IN12	*STP	*STP	*STP	*STP	*STP	-
18A		IN13	CSTR	CSTR/PWRT	CSTR	CSTR	-	-
19A		IN14	RES	RES	RES	RES	RES	RES
20A	IN15	SON	SON	SON	SON	SON	SON	
1B	Output	OUT0	PM1 (ALM1)	PM1 (ALM1)	PM1 (ALM1)	PM1 (ALM1)	PE0	LSO
2B		OUT1	PM2 (ALM2)	PM2 (ALM2)	PM2 (ALM2)	PM2 (ALM2)	PE1	LS1(TRQS)
3B		OUT2	PM4 (ALM4)	PM4 (ALM4)	PM4 (ALM4)	PM4 (ALM4)	PE2	LS2(Note2)
4B		OUT3	PM8 (ALM8)	PM8 (ALM8)	PM8 (ALM8)	PM8 (ALM8)	PE3	-
5B		OUT4	PM16	PM16	PM16	PM16	PE4	-
6B		OUT5	PM32	PM32	PM32	PM32	PE5	-
7B		OUT6	MOVE	MOVE	PM64	PM64	PE6	-
8B		OUT7	ZONE1	MODES	PM128	PM128	ZONE1	ZONE1
9B		OUT8	PZONE/ZONE2	PZONE/ZONE1	PZONE/ZONE1	PM256	PZONE/ZONE2	PZONE/ZONE2
10B		OUT9	RMDS	RMDS	RMDS	RMDS	RMDS	RMDS
11B		OUT10	HEND	HEND	HEND	HEND	HEND	HEND
12B		OUT11	PEND	PEND/WEND	PEND	PEND	PEND	-
13B		OUT12	SV	SV	SV	SV	SV	SV
14B		OUT13	*EMGS	*EMGS	*EMGS	*EMGS	*EMGS	*EMGS
15B		OUT14	*ALM	*ALM	*ALM	*ALM	*ALM	*ALM
16B	OUT15	LOAD/TRQS *ALML	*ALML	LOAD/TRQS *ALML	LOAD/TRQS *ALML	LOAD/TRQS *ALML	*ALML	
17B	Pulse Input	-						
18B		-						
19B	0V	N						
20B	0V	N						

(Note) In the table above, asterisk * symbol accompanying each code indicates a negative logic signal. PM1~PM8 are alarm binary code output signals that are used when an alarm generates.

(Note 1) In all PIO patterns other than 3, this signal can be switched with PZONE by setting Parameter No. 149 accordingly.

(Note 2) The setting will not become effective until the home return is completed.

Reference) Negative logic signal

Signals denoted by * are negative logic signals. Negative logic input signals are processed when turned OFF. Negative logic output signals normally remain ON while the power is supplied, and turn OFF when the signal is output.

Foreword
Slider Type
Wide Slider Type
Rod Type
Radial Cylinder
Wide Radial Cylinder
Table Type
Cleanroom Slider
Cleanroom Wide Slider
Dust/Splash-Proof Rod
Dust/Splash-Proof Radial Cylinder
Dust/Splash-Proof Wide Radial Cylinder
Options
Reference Data
Controller

■ Host Unit = Differential Type

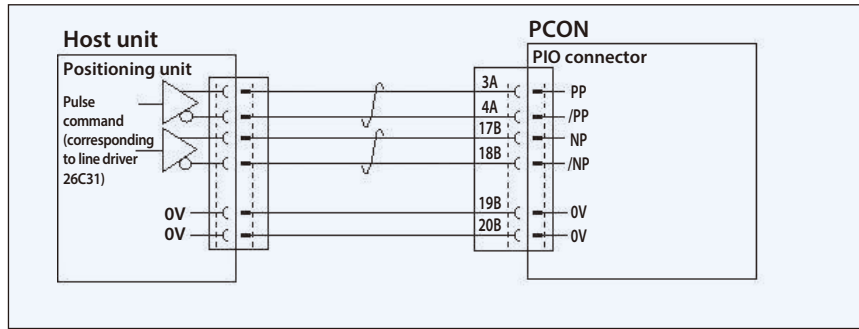

■ Host Unit = Open Collector Type

The AK-04 (optional) is needed to input pulses.

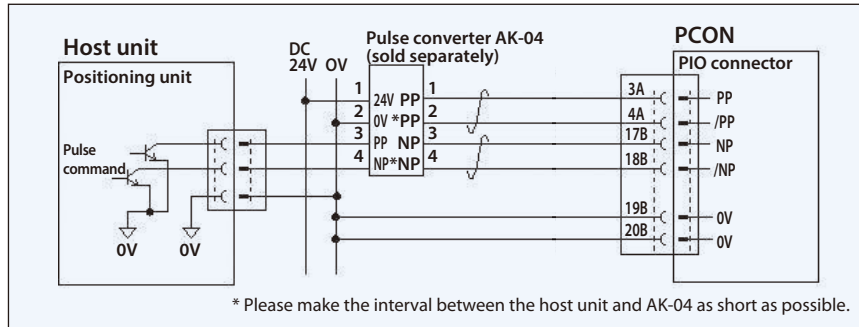

Caution: Use the same power supply for open collector input/output to/from the host and for the AK-04.

Command Pulse Input Patterns

	Command pulse-train pattern	Input terminal	Forward	Reverse	
Negative logic	Forward pulse-train	PP•/PP			
	Reverse pulse-train	NP•/NP			
	A forward pulse-train indicates the amount of motor rotation in the forward direction, while a reverse pulse-train indicates the amount of motor rotation in the reverse direction.				
	Pulse-train	PP•/PP			
	Sign	NP•/NP	Low	High	
	The command pulses indicate the amount of motor rotation, while the sign indicates the rotating direction.				
Positive logic	Phase A/B pulse-train	PP•/PP			
		NP•/NP			
	Command phases A and B having a 90° phase difference (multiplier is 4) indicate the amount of rotation and the rotating direction.				
	Forward pulse-train	PP•/PP			
	Reverse pulse-train	NP•/NP			
	Pulse-train	PP•/PP			
Sign	NP•/NP	High	Low		
Phase A/B pulse-train	PP•/PP				
	NP•/NP				

Foreword
 Slider Type
 Wide Slider Type
 Rod Type
 Radial Cylinder
 Wide Radial Cylinder
 Table Type
 Cleanroom Slider
 Cleanroom Wide Slider
 Dust/Splash-Proof Rod
 Dust/Splash-Proof Radial Cylinder
 Dust/Splash-Proof Wide Radial Cylinder
 Options
 Reference Data
 Controller

The table below lists the signal assignments for the flat cable in the pulse-train control mode. Connect an external device (such as PLC) according to this table.

Pin number	Category	I/O number	Signal abbreviation	Signal name	Parameter No.25, "PIO pattern 6/7"
1A	24V		P24	Power supply	I/O power supply +24V
2A	24V		P24	Power supply	I/O power supply +24V
3A	Pulse Input		PP	Differential pulse-train input (+)	Differential pulses are input from the host. Up to 200kpps can be input.
4A			/PP	Differential pulse-train input (-)	
5A	Input	IN0	SON	Servo ON	The servo is ON while this signal is ON, and OFF while the signal is OFF.
6A		IN1	RES	Reset	Present alarms are reset when this signal is turned ON.
7A		IN2	HOME	Home return	Home return operation is performed when this signal is turned ON.
8A		IN3	TL	Torque limit selection	When this signal is turned ON, the motor torque is limited to the value set by the parameter.
9A		IN4	CSTP	Forced stop	The actuator is forcibly stopped when this signal has remained ON for 16ms or more. The actuator decelerates to a stop at the torque set in the controller and the servo turns OFF.
10A		IN5	DCLR	Deviation counter clear	This signal clears the deviation counter.
11A		IN6	BKRL	Forced brake release	The brake is forcibly released.
12A		IN7	RMOD	Operation mode switching	The operation mode can be switched when the MODE switch on the controller is set to AUTO. (AUTO when this signal is OFF, and to MANU when the signal is ON.)
13A		IN8	RSTR*1	Reference position movement command	When this signal turns on, the actuator moves to the reference position set in parameter No.167. *1: Used only in PIO Pattern 7.
14A		IN9	NC	-	Not used
15A		IN10	NC	-	Not used
16A		IN11	NC	-	Not used
17A		IN12	NC	-	Not used
18A		IN13	NC	-	Not used
19A		IN14	NC	-	Not used
20A	IN15	NC	-	Not used	
1B	Output	OUT0	PWR	System ready	This signal turns ON when the controller becomes ready after the main power supply has been turned on.
2B		OUT1	SV	Servo ON status	This signal turns ON when the servo is ON.
3B		OUT2	INP	Positioning complete	This signal turns ON when the amount of remaining travel pulses in the deviation counter falls within the in-position band.
4B		OUT3	HEND	Home return complete	This signal turns ON upon completion of home return.
5B		OUT4	TLR	Torque limited	This signal turns ON upon reaching the torque limit while the torque is limited.
6B		OUT5	#ALM	Controller alarm status	This signal turns ON when the controller is normal, and turns OFF when an alarm generates.
7B		OUT6	#EMGS	Emergency stop status	This signal turns ON when the emergency stop of the controller is cancelled, and turns OFF when an emergency stop is actuated.
8B		OUT7	RMDS	Operation mode status	The operation mode status is output. This signal turns ON when the controller is in the manual mode.
9B		OUT8	ALM1	Alarm code output signal	An alarm code is output when an alarm generates. For details, refer to the operation manual.
10B		OUT9	ALM2		
11B		OUT10	ALM4		
12B		OUT11	ALM8		
13B		OUT12	#ALML	Minor failure alarm	This signal turns ON when the controller is normal, and turns OFF when a message-level alarm has been generated.
14B		OUT13	REND*1	Reference position movement complete	This signal turns ON when movement to the reference point set in parameter No. 167 is completed. *1: Used only in PIO Pattern 7.
15B		OUT14	ZONE1	Zone signal 1	This signal turns ON when the current position of the actuator falls within the parameter-set range.
16B	OUT15	ZONE2	Zone signal 2		
17B	Pulse Input		NP	Differential pulse-train input (+)	Differential pulses are input from the host. Up to 200kpps can be input.
18B			/NP	Differential pulse-train input (-)	
19B	0V		N	Power supply	I/O power supply 0V
20B	0V		N	Power supply	I/O power supply 0V

Note) # indicates a negative logic signal. Negative logic signals are normally ON while the power is supplied, and turn OFF when the signal is output.

If the PCON-CB is controlled via a field network, you can select one of the following five modes to operate the actuator. Please note that the data areas required on the PLC side will vary depending on the mode.

Mode Description

	Mode	Description
0	Remote I/O mode	Similarly to the PIO specification, this mode operates by directing bytes to ON/OFF via a network. The number of positioning points and functions will vary depending on the operation patterns (PIO patterns) set by the controller's parameters.
1	Position/simple direct value mode	The target position value is directly input, while all other operational conditions (speed, acceleration, etc) are set by indicating the position number corresponding to the desired operating conditions from the position data table.
2	Half direct value mode	The actuator is operated by directly inputting values for speed, acceleration rate and push current, as well as the target position.
3	Full direct value mode	The actuator is operated by directly inputting values for the target position, speed, acceleration rate and push current, etc. In addition, you are able to read the current position, current speed, and the specified current, etc.
4	Remote I/O mode 2	This mode is the same as the remote I/O mode above, with the added functionality of reading current position and the command motor current.

Required Data Size for Each Network

		DeviceNet	CC-Link	PROFIBUS-DP	CompoNet	MECHATROLINK I, II	EtherCAT	EtherNet/IP	PROFINET IO
0	Remote I/O mode	2 bytes	1 station	2 bytes	2 bytes	*	2 bytes	2 bytes	2 bytes
1	Position/simple direct value mode	8 bytes	1 station	8 bytes	8 bytes	*	8 bytes	8 bytes	8 bytes
2	Half direct value mode	16 bytes	2 stations	16 bytes	16 bytes	*	16 bytes	16 bytes	16 bytes
3	Full direct value mode	32 bytes	4 stations	32 bytes	32 bytes	× (Note 1)	32 bytes	32 bytes	32 bytes
4	Remote I/O mode 2	12 bytes	1 station	12 bytes	12 bytes	*	12 bytes	12 bytes	12 bytes

* No required data size is set for MECHATROLINK I & II.

(Note 1) Please note that the MECHATROLINK specification does not support the full direct value mode.

List of Functions by Operation Mode

	Remote I/O mode	Position/simple direct value mode	Half direct value mode	Full direct value mode (Note 1)	Remote I/O mode 2
Number of positioning points	512 points	768 points	Unlimited	Unlimited	512 points
Operation by direct position data input	×	○	○	○	×
Direct speed/acceleration input	×	×	○	○	×
Push-motion operation	○	○	○	○	○
Current position read	×	○	○	○	○
Current speed read	×	×	○	○	×
Operation by position number input	○	○	×	×	○
Completed position number read	○	○	×	×	○

* ○ indicates that the operation is supported, and X indicates that it is not supported.

(Note 1) Please note that the MECHATROLINK specification does not support the full direct value mode.

<PCON-CB/CGB>

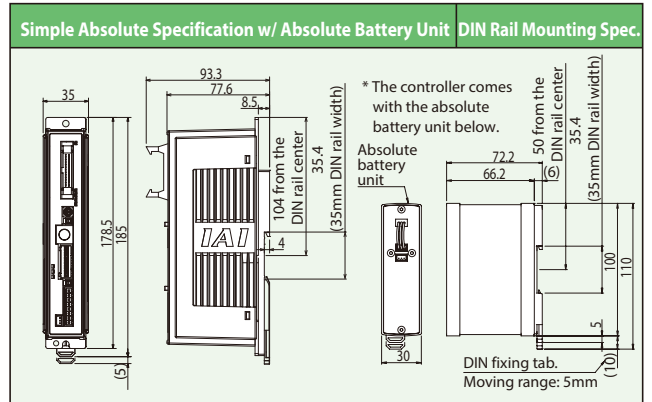
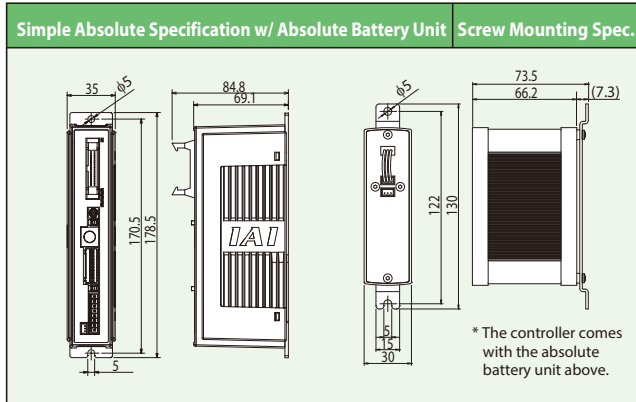
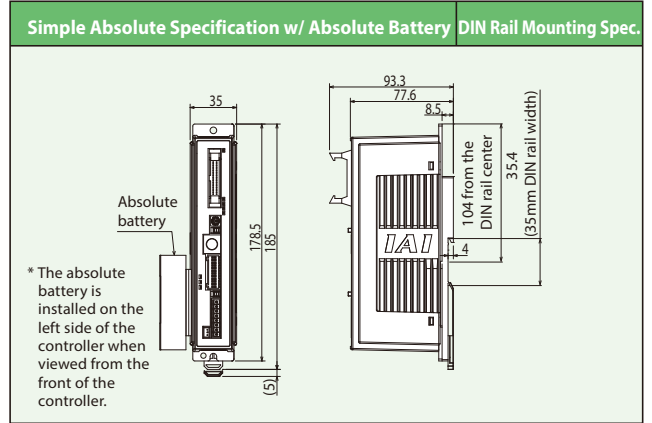
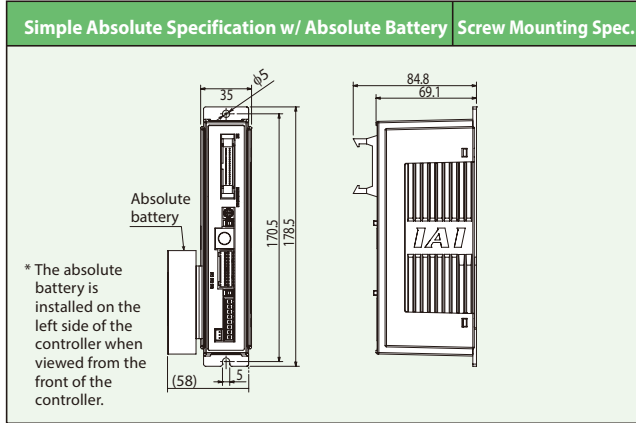
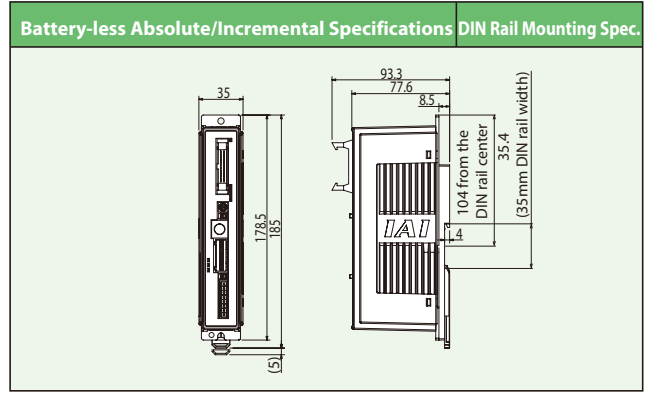
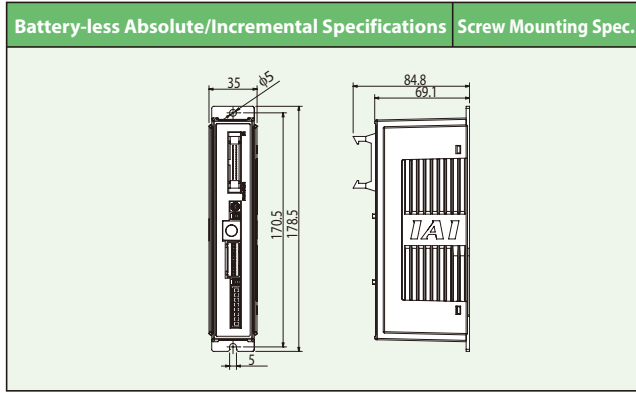

<PCON-CFB/CGFB>

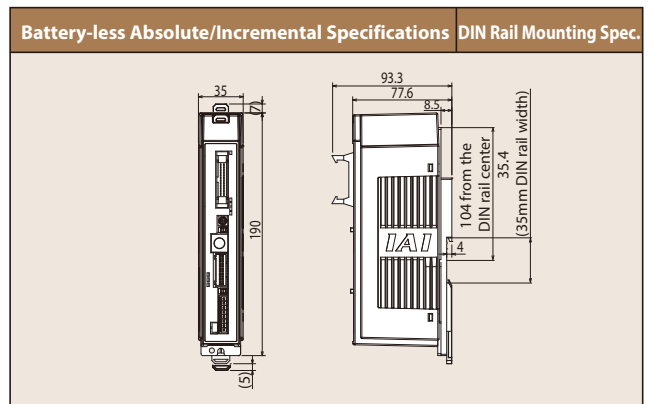
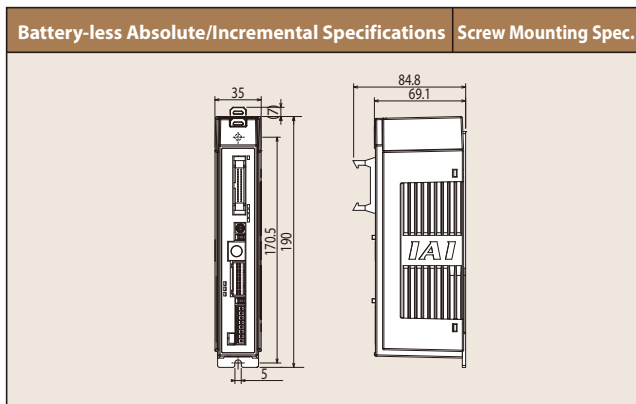

Foreword
Slider Type
Wide Slider Type
Rod Type
Radial Cylinder
Wide Radial Cylinder
Table Type
Cleanroom Slider
Cleanroom Wide Slider
Dust/Splash-Proof Rod
Dust/Splash-Proof Radial Cylinder*
Dust/Splash-Proof Wide Radial Cylinder
Options
Reference Data
Controller

Item				Description	
				PCON-CB/CGB	PCON-CFB/CGFB
Number of controlled axes				1 axis	
Power supply voltage				24VDC±10%	
Load current (including control-side current consumption) (Note 1)	RCP2 RCP3	Motor type	20P, 28P, 28SP	1A max.	
			35P, 42P, 56P	2.2A max.	
			60P, 86P		6A max.
	RCP4 RCP5	Motor type	28P, 35P, 42P, 42SP, 56P	High-output setting disabled: 2.2A max.	
			56SP, 60P, 86P	High-output setting enabled: 3.5A rated/4.2A max.	
	RCP6	Motor type	28P, 35P, 42P, 56P	High-output setting disabled: 2.2A max.	
			High-output setting enabled: 3.5A rated/4.2A max.		
56SP, 60P				5.7A max.	
Electromagnetic brake power (for actuator with brake)				24VDC±10% 0.15A max.	24VDC±10% 0.5A max.
Inrush current (Note 2)				8.3A	10A
Momentary power failure resistance				500µs max.	
Compatible encoder				High-resolution battery-less absolute encoder: Resolution 8,192 pulses/rev	
				Battery-less absolute encoder: Resolution 800 pulses/rev	
				Incremental encoder: Resolution 800 pulses/rev	
Actuator cable length				20m max.	
External interface	PIO specification			Dedicated 24VDC signal input/output (NPN/PNP selection) ... Input max. of 16 points, output max. of 16 points, cable length max. of 10m	
	Field network specification			DeviceNet, CC-Link, PROFIBUS-DP, CompoNet, MECHATROLINK-I/II/III, EtherCAT, EtherNet/IP, PROFINET IO	
Data setting, input method				PC compatible software, touch panel teaching pendant	
Data retention memory				Position data and parameters are saved in non-volatile memory. (No limit to rewrite)	
Operation mode				Positioner mode / pulse-train control mode (selectable by parameter setting)	
Number of positioner-mode positions				Up to 512 points for positioner type or up to 768 points for network type*The total number of positioning points varies depending on which PIO pattern is selected.	
Pulse-train interface	Input pulse			Differential type (line-driver type): 200kpps max., cable length up to 10m	
				Open-collector method: Not supported * If the host uses open-collector outputs, use AK-04 (optional, sold separately) to change them to differential outputs.	
	Command pulse magnification (Electronic gear: A/B)			1/50 < A/B < 50/1 Setting range of A and B (set by parameters): 1~4,096	
Feedback pulse output			None		
Insulation resistance				Not less than 10MΩ at 500VDC	
Electric shock protection mechanism				Class I, basic insulation	
Mass (Note 3)	Battery-less absolute specification / Incremental specification			Screw mounting type: Not more than 250g	Screw mounting type: Not more than 270g
	Simple absolute specification (including 190g for battery)			DIN rail mounting type: Not more than 285g	DIN rail mounting type: Not more than 305g
Cooling method				Natural air cooling	Forced air cooling
Environment	Ambient operating temperature			0~40°C	
	Ambient operating humidity			Not more than 85% RH (non-condensing)	
	Operating ambience			Free from corrosive gases	
	Degree of protection			IP20	

Note 1) 0.3A higher for the field network specification.

Note 2) Inrush current flows for approx. 5msec after the power is input (at 40°C). Please note that the inrush current value varies depending on the impedance of the power line.

Note 3) 30g heavier for the field network specification.

Touch panel teaching pendant

■ **Features** A teaching device equipped with functions such as position teaching, trial operation, and monitoring.

■ **Model** **TB-02-□**

■ **Configuration**

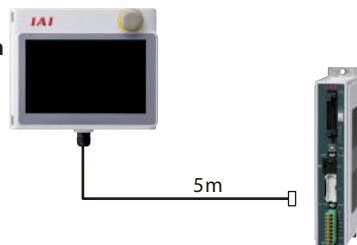

Specifications

Rated voltage	24VDC
Power consumption	3.6W or less (150mA or less)
Ambient operating temperature	0~40°C
Ambient operating humidity	20~85% RH (Non-condensing)
Environmental resistance	IP20
Weight	470g (TB-02 unit only)

PC compatible software (Windows only)

■ **Features** The start-up support software which comes equipped with functions such as position teaching, trial operation, and monitoring. A complete range of functions needed for making adjustments contributes to a reduced start-up time.

■ **Model** **RCM-101-MW** (with an external device communication cable + RS232 conversion unit)

Please contact IAI for the current supported versions.

■ **Configuration**

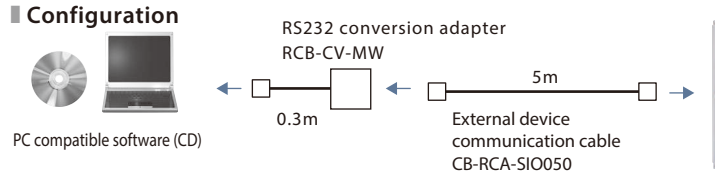

Supported Windows versions:
7 / 8 / 10



■ **Model** **RCM-101-USB** (with an external device communication cable + USB conversion adapter + USB cable)

Please contact IAI for the current supported versions.

■ **Configuration**

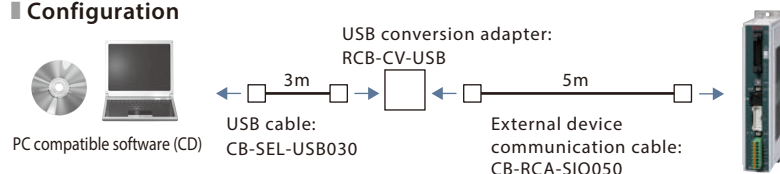

Absolute battery unit

■ **Overview** A battery unit, supplied as an accessory for the simple absolute specification, which serves to back up the current position of the controller.

■ **Model** **SEP-ABU** (DIN rail mounting specification)

SEP-ABUS (Screw mounting specification)

■ **Specification**

Item	Specification
Ambient operating temp. & humidity	0~40°C (around 20°C is desirable), 95% RH or less (non-condensing)
Operating ambience	Free from corrosive gases
Absolute battery	Model: AB-7 (Ni-MH battery/Life: approx. 3 years)
Absolute battery unit connecting cable	Model: CB-APSEP-AB005 (length: 0.5m)
Weight	Standard type: approx.230g/Dust-proof type: approx.260g

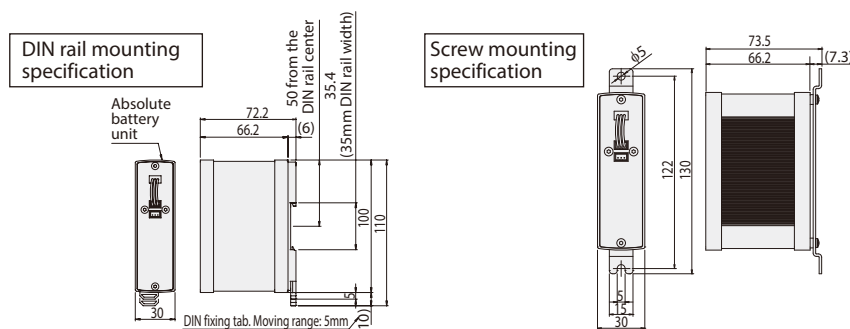

Replacement battery

■ **Overview** Replacement battery used with the absolute battery box.

■ **Model** **AB-7**



Dummy plug

■ **Overview** This plug is required when the safety category specification (PCON-CGB/CGFB) is used.

■ **Model** **DP-5**



When placing an order for the replacement cable, please use the model number shown below.

Table of Applicable Cables

Model Number		Integrated Motor-encoder Cable	Integrated Motor-encoder Robot Cable
①	RCP6/RCP6CR/RCP6W/RCP5/RCP5CR/RCP5W (Models other than ③)	CB-CAN-MPA□□□	CB-CAN-MPA□□□-RB
②	RCP4 SA3/RA3/GR		
③	RCP6/RCP6CR RCP6W/RCP5 RCP5W	SA8/RRA8 RA7 (High-thrust specification)/RA8/RA10 WSA16/WRA16	CB-CFA3-MPA□□□-RB
④	RCP4/RCP4CR/RCP4W (Models other than ②, ⑤, ⑥)	CB-CA-MPA□□□	CB-CA-MPA□□□-RB
⑤	RCP4 RA6C (High-thrust specification)	CB-CFA2-MPA□□□	CB-CFA2-MPA□□□-RB
⑥	RCP4W RA7C (High-thrust specification)		
⑦	RCP3		
⑧	RCP2	GRSS/GRLS/GRST/GRHM/GRHB SRA4R/SRGS4R/SRGD4R	CB-APSEP-MPA□□□
⑨		RTBS/RTBSL RTCS/RTCSL	CB-RPSEP-MPA□□□
⑩	RCP2CR RCP2W	GRS/GRM GR3SS/GR3SM	CB-CAN-MPA□□□-RB
⑪		RTBS/RTBSL RTCS/RTCSL/RTB/RTBL/RTC/RTCL RTBB/RTBBL/RTCB/RTCBL	
⑫	RCP2 RCP2CR RCP2W	RA10/HS8 RA8	CB-CFA-MPA□□□-RB
⑬	RCP2W	SA16C	
⑭	RCP2 (Models other than ⑧ ~ ⑬)	-	CB-PSEP-MPA□□□

Model Number	PIO Flat Cable
⑮	PCON-CB/CGB, CFB/CGFB CB-PAC-PIO□□□

Model Number **CB-CAN-MPA□□□/CB-CAN-MPA□□□-RB**

* Please indicate the cable length (L) in □□□, maximum 20m, e.g.) 080 = 8m

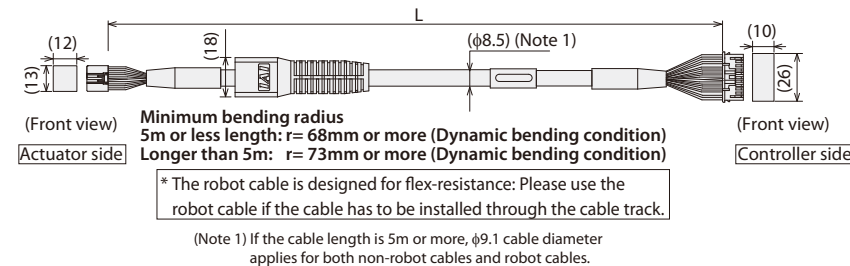

Pin No	Signal name	Pin No	Signal name
3	φA	1	φA
5	VMM	2	VMM
10	φB	3	φB
9	VMM	4	VMM
4	φ A	5	φ A
15	φ B	6	φ B
8	LS+	7	LS+
14	LS-	8	LS-
12	SA(mABS)	11	SA(mABS)
17	SB(mABS)	12	SB(mABS)
1	A+	13	A+
6	A-	14	A-
11	B+	15	B+
16	B-	16	B-
20	BK+	9	BK+
2	BK-	10	BK-
21	VCC	17	VCC
7	GND	19	GND
18	VPS	18	VPS
13	LS_GND	20	LS_GND
19	-	22	-
22	-(CFVcc)	21	-(CFVcc)
23	-	23	-
24	FG	24	FG

Model Number **CB-CFA3-MPA□□□/ CB-CFA3-MPA□□□-RB**

* Please indicate the cable length (L) in □□□, maximum 20m, e.g.) 080 = 8m

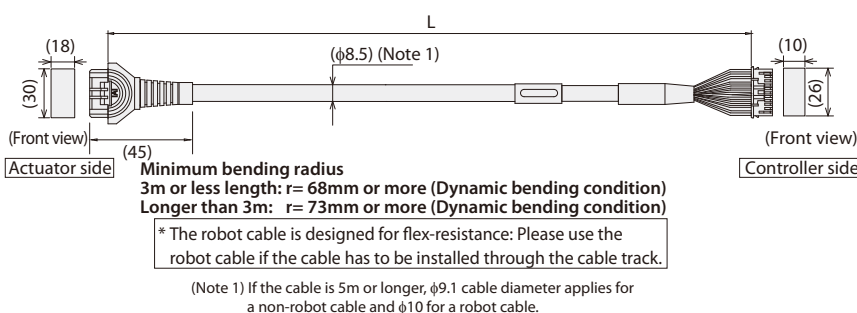

Actuator side 1-1827863-1 (AMP)		Controller side PADP-24V-1-5 (J.S.T.MFG.CO.,LTD.)	
Pin No	Signal name	Pin No	Signal name
A1	φA	1	φA
B1	VMM	2	VMM
A2	φ A	5	φ A
B2	φ B	3	φ B
A3	VMM	4	VMM
B3	φ B	6	φ B
A4	LS+	7	LS+
B4	LS-	8	LS-
A6	SA(mABS)	11	SA(mABS)
B6	SB(mABS)	12	SB(mABS)
A7	A+	13	A+
B7	A-	14	A-
A8	B+	15	B+
B8	B-	16	B-
A5	BK+	9	BK+
B5	BK-	10	BK-
A9	LS_GND	20	LS_GND
B9	VPS	18	VPS
A10	VCC	21	VCC
B10	GND	19	GND
A11	-	17	-
B11	FG	22	-
		23	-
		24	FG

When placing an order for the replacement cable, please use the model number shown below.

Model Number **CB-CA-MPA**□□□/ **CB-CA-MPA**□□□-**RB**

* Please indicate the cable length (L) in □□□, maximum 20m, e.g.) 080 = 8m

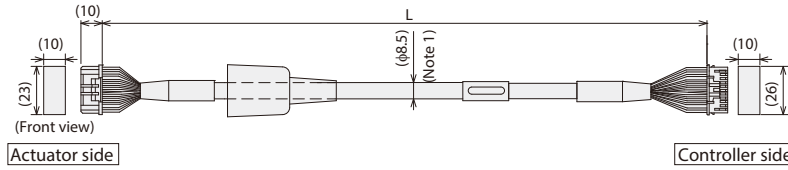

Actuator side Controller side

Minimum bending radius $r = 80\text{mm}$ or more (Dynamic bending condition)

* The robot cable is designed for flex-resistance: Please use the robot cable if the cable has to be installed through the cable track.

(Note 1) If the cable is 5m or longer, $\phi 9.1$ cable diameter applies for a non-robot cable and $\phi 10$ for a robot cable.

Actuator side 1-1827863-1 (AMP)			Controller side PADP-24V-1-S (J.S.T.MFG.CO.,LTD.)		
Pin No	Signal name	Color	Pin No	Signal name	Color
A1	$\phi A/U$	Blue (Black)	2	$\phi A/U$	Blue (Black)
B1	VMM/V	Orange (White)	5	$\phi A/W$	Green (Brown)
A2	$\phi A/W$	Green (Brown)	3	$\phi B/-$	Brown (Green)
B2	$\phi B/-$	Brown (Green)	4	VMM/V	Gray (Yellow)
A3	VMM/V	Gray (Yellow)	6	$\phi B/+$	Red (Red)
B3	$\phi B/+$	Red (Red)	7	LS+/BK+	Black (Orange)
A4	LS+/BK+	Black (Orange)	8	LS-/BK-	Yellow (Gray)
B4	LS-/BK-	Yellow (Gray)	11	-/A+	Blue (White)
A6	-/A+	Blue (White)	12	-/A-	Orange (Yellow)
B6	-/A-	Orange (Yellow)	13	A+/B+	Green (Red)
A7	A+/B+	Green (Red)	14	A-/B-	Brown (Green)
B7	A-/B-	Brown (Green)	15	B+/Z+	Gray (Black)
A8	B+/Z+	Gray (Black)	16	B-/Z-	Red (Brown)
B8	B-/Z-	Red (Brown)	9	BK+/LS+	Blue (Black)
A5	BK+/LS+	Blue (Black)	10	BK-/LS-	Orange (Brown)
B5	BK-/LS-	Orange (Brown)	20	LS_GND	Green (Green)
A9	LS_GND	Green (Green)	18	GND	Brown (Red)
B9	GND	Brown (Red)	17	VCC	Gray (White)
A10	VCC	Gray (White)	19	GND	Red (Yellow)
B10	GND	Red (Yellow)	21	-	-
A11	-	-	22	-	-
B11	FG	Black (-)	23	-	-
			24	FG	Black (-)

* () indicates the color of the robot cable.

Model Number **CB-CFA-MPA**□□□/ **CB-CFA-MPA**□□□-**RB**

* Please indicate the cable length (L) in □□□, maximum 20m, e.g.) 080 = 8m

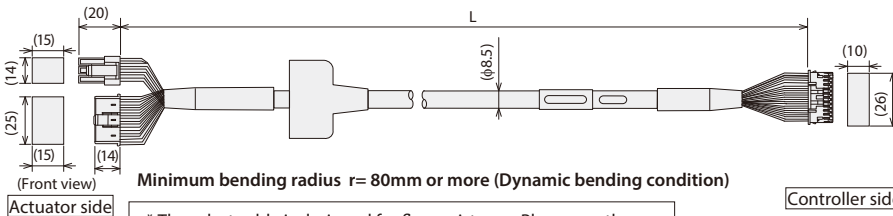

Actuator side Controller side

Minimum bending radius $r = 80\text{mm}$ or more (Dynamic bending condition)

* The robot cable is designed for flex-resistance: Please use the robot cable if the cable has to be installed through the cable track.

(Note 1) If the cable is 3m or longer, $\phi 9.1$ cable diameter applies for a non-robot cable and $\phi 10$ for a robot cable.

Actuator side SLP-06V (NICHATSU)			Controller side PADP-24V-1-S (J.S.T.MFG.CO.,LTD.)		
Pin No	Signal name		Pin No	Signal name	
1	ϕA		1	ϕA	
2	VMM		2	VMM	
4	ϕB		3	ϕB	
5	VMM		4	VMM	
3	ϕA		5	ϕA	
6	ϕB		6	ϕB	
5	NC		11	NC	
6	NC		12	NC	
13	LS+		7	LS+	
14	LS-		8	LS-	
1	A+		13	A+	
2	A-		14	A-	
3	B+		15	B+	
4	B-		16	B-	
16	BK+		9	BK+	
17	BK-		10	BK-	
12	VCC		21	VCC	
9	GND		19	GND	
11	VPS		18	VPS	
10	NC		20	NC	
18	FG		24	FG	
15	NC		22	NC	
7	NC		23	NC	
8	NC		23	NC	

Model Number **CB-CFA2-MPA**□□□/ **CB-CFA2-MPA**□□□-**RB**

* Please indicate the cable length (L) in □□□, maximum 20m, e.g.) 080 = 8m

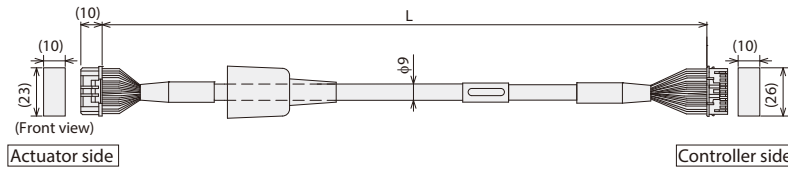

Actuator side Controller side

Minimum bending radius $r = 68\text{mm}$ or more (Dynamic bending condition)

* The robot cable is designed for flex-resistance: Please use the robot cable if the cable has to be installed through the cable track.

Actuator side 1-1827863-1 (AMP)			Controller side PADP-24V-1-S (J.S.T.MFG.CO.,LTD.)		
Pin No	Signal name		Pin No	Signal name	
A1	ϕA		1	ϕA	
B1	VMM		2	VMM	
A2	ϕA		5	ϕA	
B2	ϕB		3	ϕB	
A3	VMM		4	VMM	
B3	ϕB		6	ϕB	
A4	LS+		7	LS+	
B4	LS-		8	LS-	
A6	-		11	-	
B6	-		12	-	
A7	A+		13	A+	
B7	A-		14	A-	
A8	B+		15	B+	
B8	B-		16	B-	
A5	BK+		9	BK+	
B5	BK-		10	BK-	
A9	LS_GND		20	LS_GND	
B9	VPS		18	VPS	
A10	VCC		17	VCC	
B10	GND		19	GND	
A11	-		21	-	
B11	FG		22	-	
			23	-	
			24	FG	

Model Number **CB-APSEP-MPA**□□□

* Robot cable is standard.

* Please indicate the cable length (L) in □□□, maximum 20m, e.g.) 080 = 8m

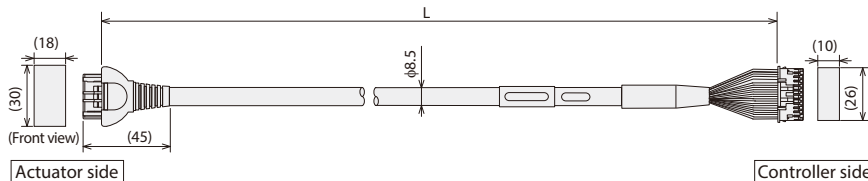

Actuator side Controller side

Minimum bending radius $r = 68\text{mm}$ or more (Dynamic bending condition)

* Only robot cable is available for this model.

Actuator side			Controller side		
Terminal number		[PCON] (ACON)	Terminal number		
A1		Black (ϕA) (U)	1		
B1		White (VMM) (V)	2		
A2		Brown (ϕA) (W)	5		
B2		Green (ϕB) (-)	3		
A3		Yellow (VMM) (+)	4		
B3		Red (ϕB) (+)	6		
A4		Orange (LS+) (BK+)	7		
B4		Gray (LS-) (BK-)	8		
A6		White (-) (A+)	11		
B6		Yellow (-) (A-)	12		
A7		Red (A+) (B+)	13		
B7		Green (A-) (B-)	14		
A8		Black (B+) (Z+)	15		
B8		Black (B-) (Z-)	16		
A5		Black (identification tape) (BK+) (LS+)	9		
B5		Brown (identification tape) (BK-) (LS-)	10		
A9		Green (identification tape) (GNDLS) (GNDLS)	20		
B9		Red (identification tape) (VPS) (VPS)	18		
A10		White (identification tape) (VCC) (VCC)	17		
B10		Yellow (identification tape) (GND) (GND)	19		
A11		NC	21		
B11		Shield (FG) (FG)	22		
		NC	23		

Model Number **CB-PSEP-MPA** □ □ □

* Please indicate the cable length (L) in □ □ □, maximum 20m, e.g.) 080 = 8m

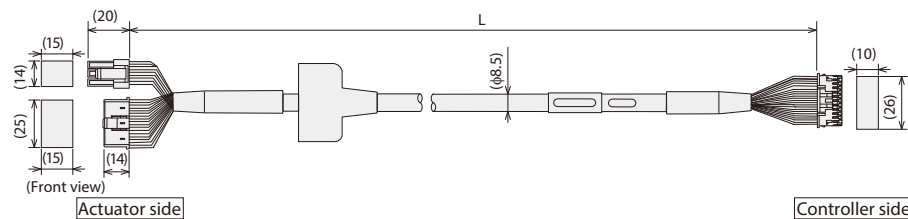

Minimum bending radius $r = 68\text{mm}$ or more (Dynamic bending condition)

* Only robot cable is available for this model.

Actuator side Terminal number	Color / Label	Controller side Terminal number
1	Black (φA)	1
2	White (VMM)	2
3	Red (φB)	3
4	Green (VMM)	4
5	Brown (φA)	5
6	Yellow (φB)	6
7	Orange (BK-)	7
8	Gray (BK-)	8
9	NC	9
10	NC	10
11	NC	11
12	NC	12
13	Black (LS-)	13
14	Brown (LS-)	14
15	White (A+)	15
16	Yellow (A-)	16
17	Green (B-)	17
18	White (identification tape) (VCC)	18
19	Yellow (identification tape) (VPS)	19
20	Red (identification tape) (GND)	20
21	Green (identification tape) (reserve)	21
22	NC	22
23	NC	23
24	Shield (FG)	24

Model Number **CB-RPSEP-MPA** □ □ □

* Please indicate the cable length (L) in □ □ □, maximum 20m, e.g.) 080 = 8m

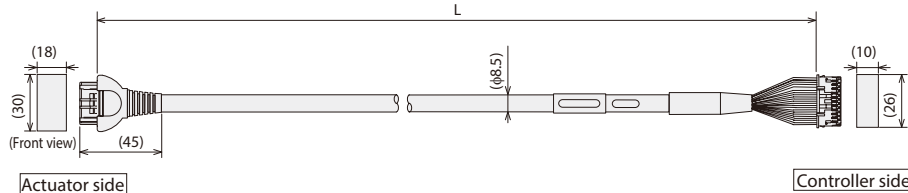

Minimum bending radius $r = 68\text{mm}$ or more (Dynamic bending condition)

* Only robot cable is available for this model.

Actuator side Terminal number	Color / Label	Controller side Terminal number
A1	Black (φA)	1
B1	White (VMM)	2
A2	Brown (φA)	3
B2	Green (φB)	4
A3	Yellow (VMM)	5
B3	Red (φB)	6
A6	Orange (LS-)	7
B6	Gray (LS-)	8
A7	Red (A+)	13
B7	Green (A-)	14
A8	Black (B-)	15
B8	Brown (B-)	16
A4	NC	-
B4	NC	-
A5	Black (identification tape) (BK-)	9
B5	Brown (identification tape) (BK-)	10
A9	Green (identification tape) (GND/LS)	20
B9	Red (identification tape) (VPS)	18
A10	White (identification tape) (VCC)	17
B10	Yellow (identification tape) (GND)	19
A11	NC	21
B11	Shield (FG) (FG)	24
	NC	22
	NC	23

Model Number **CB-PAC-PIO** □ □ □

* Please indicate the cable length (L) in □ □ □, maximum 10m, e.g.) 080 = 8m

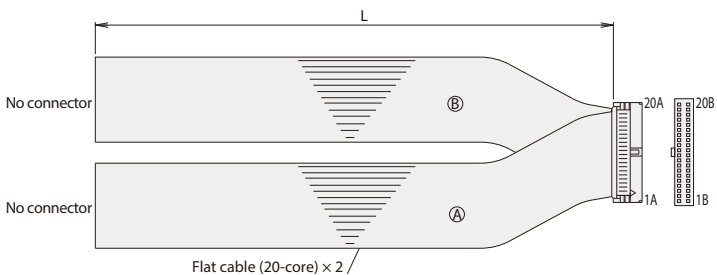

HIF6-40D-1.27R

No.	Signal name	Cable color	Wiring	No.	Signal name	Cable color	Wiring
1A	24V	Brown-1	Flat cable (20-core) x 2 (pressure-welded)	1B	OUT0	Brown-3	Flat cable (20-core) x 2 (pressure-welded) AWG28
2A	24V	Red-1		2B	OUT1	Red-3	
3A	Pulse	Orange-1		3B	OUT2	Orange-3	
4A	Input	Yellow-1		4B	OUT3	Yellow-3	
5A	IN0	Green-1		5B	OUT4	Green-3	
6A	IN1	Blue-1		6B	OUT5	Blue-3	
7A	IN2	Purple-1		7B	OUT6	Purple-3	
8A	IN3	Gray-1		8B	OUT7	Gray-3	
9A	IN4	White-1		9B	OUT8	White-3	
10A	IN5	Black-1		10B	OUT9	Black-3	
11A	IN6	Brown-2		11B	OUT10	Brown-4	
12A	IN7	Red-2		12B	OUT11	Red-4	
13A	IN8	Orange-2		13B	OUT12	Orange-4	
14A	IN9	Yellow-2		14B	OUT13	Yellow-4	
15A	IN10	Green-2		15B	OUT14	Green-4	
16A	IN11	Blue-2		16B	OUT15	Blue-4	
17A	IN12	Purple-2		17B	Pulse	Purple-4	
18A	IN13	Gray-2		18B	input	Gray-4	
19A	IN14	White-2		19B	0V	White-4	
20A	IN15	Black-2		20B	0V	Black-4	

Horizontal dotted lines for writing.

- Foreword
- Slider Type
- Wide Slider Type
- Rod Type
- Radial Cylinder
- Wide Radial Cylinder
- Table Type
- Cleanroom Slider
- Cleanroom Wide Slider
- Dust/Splash-Proof Rod
- Dust/Splash-Proof Radial Cylinder*
- Dust/Splash-Proof Wide Radial Cylinder
- Options
- Reference Data
- Controller

RCP6S with Built-in Controller

Built-in controller for RCP6S

Features

By using the gateway unit, a maximum of 16 axes* of RCP6S (relayed through a hub unit) can be operated via a field network with less wiring.

Hub unit allows us to keep the cable connected to the actuator of each axis short, and motor power supply and control signal lines can be connected as one cable between the hub unit and the RCP6S.

*The number of connectable axes will vary depending on the type of field network and its mode. Please refer to P. 273 for more information.

Control Panel for the RCP6S Built-in Controller Actuator

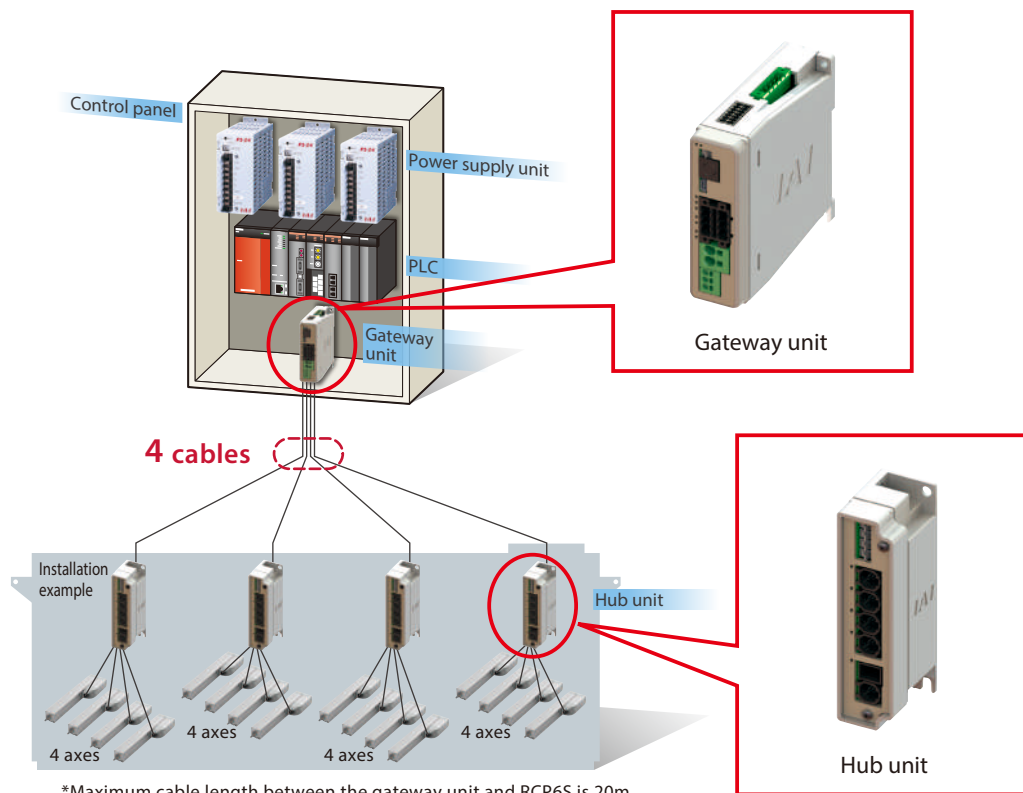

*Maximum cable length between the gateway unit and RCP6S is 20m.
If there is a hub unit in between, the maximum length is still 20m.
The cable length from the gateway unit to the hub unit needs to be 10m or less.

RCP6S Peripheral Equipment

Gateway unit is required in order to operate RCP6S.

- Gateway unit: This unit is used in order to connect RCP6S to the field network. See P. 273
- Hub unit: This unit can expand the number of axes connected to the gateway unit. See P. 277
- PLC connection unit: This unit is used to connect RCP6S directly to the PLC using Modbus serial communication. See P. 278
- Controller for RCP6S Gateway
Controllers for connection of actuators other than RCP6S to an RCP6S gateway within the system: See P. 279

Specification		Specification Description
Number of controlled axes		1 axis
Power supply voltage		24VDC±10%
Control power capacity		0.3A (Built-in controller only)
Load current (including control-side current consumption)	Motor type	28P, 35P, 42P, 56P
		56SP, 60P
Electromagnetic brake power (for actuator with brake)		24VDC±10% 0.15A (Note) For releasing brake, 0.7A for 0.2 sec is required.
Heat output		5W (Motor type 28P, 35P, 42P, 56P) 19.2W (Motor type 56SP, 60P)
Inrush current (Note 1)	Motor type	28P, 35P, 42P, 56P
		56SP, 60P
Motor control method		Weak field vector control
Compatible encoder		Resolution of battery-less absolute encoder: 8,192 pulses/rev
Serial communication interface (SIO port)		RS485: 1CH (Modbus protocol RTU/ASCII compliant) Speed: 9.6~230.4Kbps 1CH (Modbus protocol RTU)
External interface		Field bus connection: DeviceNet, CC-Link, PROFIBUS-DP, EtherCAT, EtherNet/IP, PROFINET-IO. (Note) Additional gateway unit connection is required.
Data setting, input method		PC compatible software, touch panel teaching pendant
Data retention memory		Position data and parameters are saved in non-volatile memory. (No limit to rewrite)
LED display		SV (green) / ALM (red): Servo ON / Alarm triggered and emergency stop
Insulation resistance		Not less than 10MΩ at 500VDC
Electric shock protection mechanism		Class I basic insulation
Cooling method		Natural air cooling

Note1: Inrush current will flow for approximately 5msec after the power is turned on (at 40°C).

Inrush current value differs depending on the impedance on the power supply line.

<The Calculation of Number of Connectable Axes and Power Capacity>

To calculate the number of axes connectable to one gateway unit and the current amperage of 24VDC, figure out (1) to (4) below and follow (5).

(1) The Calculation of Number of Connectable Axes, and Motor Current Consumption

Condition 1: Sum of motor current consumption connectable to one hub unit: 12.8A or less

Condition 2: Number of controlled axes connectable to corresponding 1 unit: 4 axes or less

* By adjusting the number of connected axes or motor type, select the connected axes so each hub unit satisfies the formulas below.

● Sum of motor current consumption for hub unit = Motor current consumption of 1st axis + Motor current consumption of 2nd axis (if connected)
+ Motor current consumption of 3rd axis (if connected)
+ Motor current consumption of 4th axis (if connected) ≤ 12.8A.....①

● Sum of motor current consumption = Motor current consumption of hub unit 1st unit
+ Motor current consumption of 2nd hub unit (if connected)
+ Motor current consumption of 3rd hub unit (if connected)
+ Motor current consumption of 4th hub unit (if connected)②

(2) Control Power Current Consumption: 0.3A × Number of actuator + 0.6A (gateway unit) + 0.3A × Number of hub unit③

(3) Inrush Current: 8.3A (RCP6S Motor type 28P, 35P, 42P, 56P,RCM-P6PC)

10A (RCP6S Motor type 56SP, 60P,RCM-P6AC,RCM-P6DC)④

(4) Current Consumption of Brake Release(RCP6,RCP6S) : Number of actuators with brake × 0.7A⑤

* When servo is on, it should be 0.5sec or less, after that retaining of released status should be 0.1A / axis.

When using control power and motor power in common, calculate by the number of actuators x 0.1A.

(5) Selection of Power Supply:

Usually, the rated current is to be approximately 1.2 times higher than the total of Control Power ② + ③ + ⑤ above considering approximately 20% of margin to the load current.

However, although it is for a short time, current of ④ will flow, so please take this into account and select a "peak load support" specification or select a power supply that has sufficient headroom. Avoid having all of the current from ④ from flowing at the same time by turning the servos on at different times from each other (Note 1).

If a power supply with insufficient headroom is selected, voltage may drop instantaneously. Be careful especially when selecting a power source equipped with remote sensing.

Note 1: The timing to turn the servo on can be tuned in Parameter No. 165 [Latency after Shutdown Release].

(Note) Ensure motor and control power supplies reference the same potential when using multiple power supplies.

Gateway Unit (RCM-P6GW)

Features:

This unit is used in order to connect RCP6S to the field network.

Details:

- Compatible with many field networks.
(Applicable networks: CC-Link, DeviceNet, PROFIBUS-DP, EtherCAT, EtherNet/IP, PROFINET-IO)
- Motor power and control power for all of the connected axes can be supplied through the gateway unit.
- Monitoring during AUTO is possible.
- A mini-USB connection comes standard.
- Each channel has MPO/MPI for drive source cutoff.
- Brake can be forcibly released by supplying power to the brake release input terminal for each channel. (In the case that the actuator is directly connected)
- When RCP6S is directly connected to the gateway unit, the communication time is 10msec. When RCP6S is connected to the gateway unit through the hub unit, the communication time is 40msec. The communication time does not become longer even if the connected axes increase.



Model Configuration

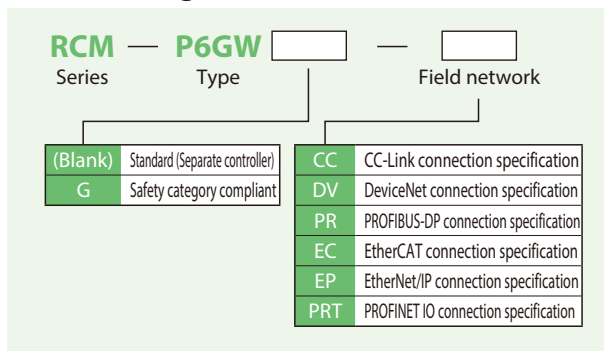

Available Models

Models
CC-Link specification
DeviceNet specification
PROFIBUS-DP specification
EtherCAT specification
EtherNet/IP specification
PROFINET IO specification
Safety category CC-Link specification
Safety category DeviceNet specification
Safety category PROFIBUS-DP specification
Safety category EtherCAT specification
Safety category EtherNet/IP specification
Safety category PROFINET IO specification

*Dummy plug DP-5 is supplied with the safety category specification.

Connection Image

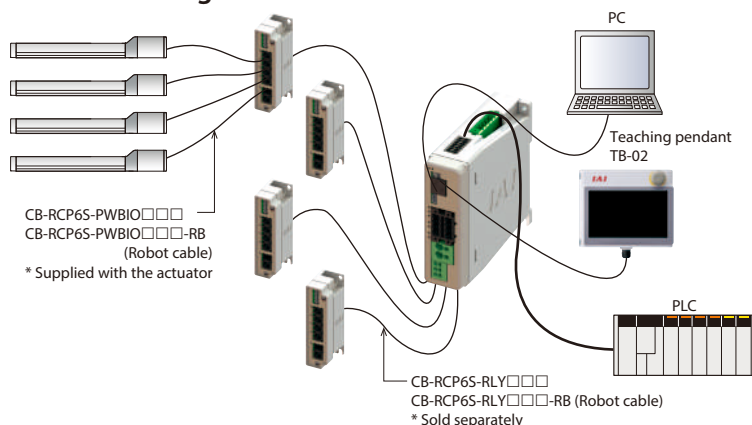

Up to 16 axes^(*) of RCP6S can be connected per gateway unit with hub units.^(*)

Because both the motor power and control power for all the axes connected to the gateway unit can be supplied together, the required wiring for RCP6S can be connected as one cable between the hub and RCP6S.

Also RCP6S can be directly connected to the gateway unit.

(*1) Number of connectable axes varies depending on the type of the field network. Please see "Number of connectable axes" table for details.

(*2) Hub unit: Refer to P. 277 for the details.

The Number of Connectable Axes:

Maximum connectable axes are as shown below.

	Direct value mode	Simple direct value mode	Positioner 1	Positioner 2	Positioner 3	Positioner 5
CC-Link	16	16	16	16	16	16
DeviceNet	8	16	16	16	16	16
PROFIBUS-DP	8	16	16	16	16	16
EtherCAT	8	16	16	16	16	16
EtherNet/IP	8	16	16	16	16	16
PROFINET IO	8	16	16	16	16	16

These control modes are available to choose from when using the RCP6S via field network. Data required for operation (target position, speed, acceleration, push current value, etc.) are written by a PLC or other host controller into the specified addresses.

Operation mode	Description	Overview
Positioner 1/ Simple direct numerical value mode (Simple direct mode)	Positioner 1 mode can store up to 768 points of position data, and can move to the stored position. Both modes allow monitoring the current position numerically with 0.01mm increments. The simple direct numerical value mode can modify any of the stored target positions by numerical value. Both modes allow monitoring the current position numerically with 0.01mm increments.	
Direct numerical control mode (Direct indication/ Full mode)	This mode allows designating the target position, speed, acceleration/deceleration, and motor current percentage for pushing numerically. Also, it is capable of monitoring the current position, current speed, and the motor current command value with 0.01mm increments.	
Positioner 2 mode	Positioner 2 mode can store up to 768 points of position data, and can move to the stored position. This mode does not allow monitoring of the current position. This is a mode that has less in/out data transfer volume than the Positioner 1 mode.	
Positioner 3 mode	Positioner 3 mode can store up to 256 points of position data, and can move to the stored position. This mode does not allow monitoring of the current position. This is a mode that has less in/out data transfer volume than the Positioner 2 mode, and operates with a minimum number of signals.	
Positioner 5 mode	Positioner 5 mode can store up to 16 points of position data, and can move to the stored position. This is a mode that has less position table than the Positioner 2 mode, and allows monitoring the current position numerically with 0.01mm increments.	

Foreword
Slider Type
Wide Slider Type
Rod Type
Radial Cylinder
Wide Radial Cylinder
Table Type
Cleanroom Slider
Cleanroom Wide Slider
Dust/Splash-Proof Rod
Dust/Splash-Proof Radial Cylinder*
Dust/Splash-Proof Wide Radial Cylinder
Options
Reference Data
Controller

List of Functions by Operation Mode

	Simple direct value mode	Positioner 1 mode	Direct numerical control mode (Direct indication/Full mode)	Positioner 2 mode	Positioner 3 mode	Positioner 5 mode
Number of positioning points	768 points	768 points	Unlimited	768 points	256 points	16 points
Home return operation	○	○	○	○	○	○
Positioning operation	○	△	○	△	△	△
Speed, acceleration/deceleration settings	△	△	○	△	△	△
Different acceleration and deceleration settings	△	△	×	△	△	△
Pitch Feed (Incremental)	△	△	○	△	×	△
Push-motion operation	△	△	○	△	△	△
Speed changes while moving	△	△	○	△	△	△
Pausing	○	○	○	○	○	○
Zone signal output	△	△	△	△	△	△
Position zone signal output	△	△	×	△	×	×
Current position reading (Resolution)	○ (0.01mm)	○ (0.01mm)	○ (0.01mm)	×	×	○ (0.1mm)

* ○ indicates that direct setting is possible, △ indicates position data or parameter input is required, x indicates the operation is not supported.

Names and Functions of Each Part

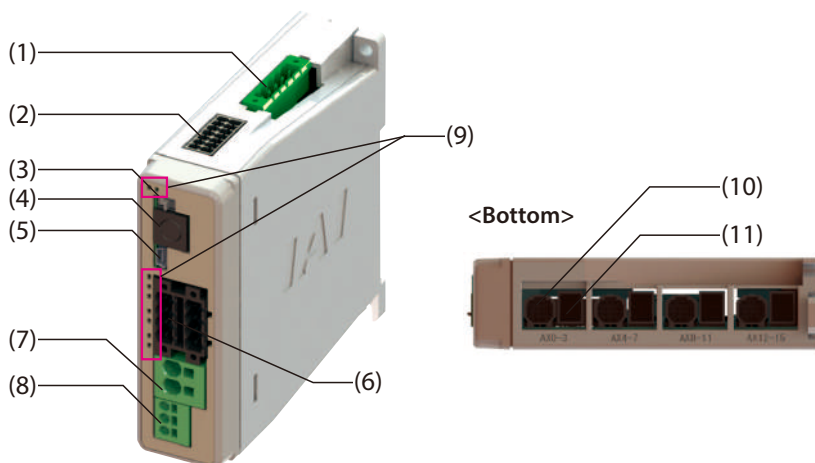

- (1) Field network connector
The connector used to connect to the field network.
- (2) System I/O connector
The connector for emergency stop input, external AUTO/MANU switchover input, and brake release input in case of directly connecting RCP6S to a gateway unit.
- (3) Operation mode setting switch
For switching the operation mode between automatic (AUTO) and manual (MANU).
- (4) SIO connector
The connector used to connect a teaching pendant or PC software.
- (5) USB connector
The connector used to connect the PC software.
- (6) Drive power cut-off connector
The connector used to connect an external drive power cut-off relay to the 24VDC power supply from the motor power connector.
- (7) Motor power supply connector
For 24VDC motor power supply for a gateway unit.
- (8) Control power supply connector
The connector for the gateway unit 24VDC control power supply and the frame ground (FG).
- (9) Status display LED
Displays the status of the gateway unit.

Code	LED	Display color and operating status.
LED1	SYS	System status Ready (Green) Alarm (Red)
LED2	AUTO	Operation mode (AUTO/MANU) status Automatic operation mode (Green)
LED3	EMG	Emergency stop (EMG) status Emergency stop (EMG)(Red)
LED4	T. ERR	Bus communication error in the controller T.ERR (Orange)
LED5	C. ERR	Field bus network communication error C.ERR (Orange)

- (10) Axis control connector
The connector used to supply power and control signals (24VDC control power, 24VDC motor power, communication line, brake release signal, emergency stop status, etc.) from the gateway unit to the hub unit or RCP6S.
- (11) Axis power supply connector
The connector used to supply 24VDC motor power via gateway unit to either a RCP6S or a hub unit.

External Dimensions

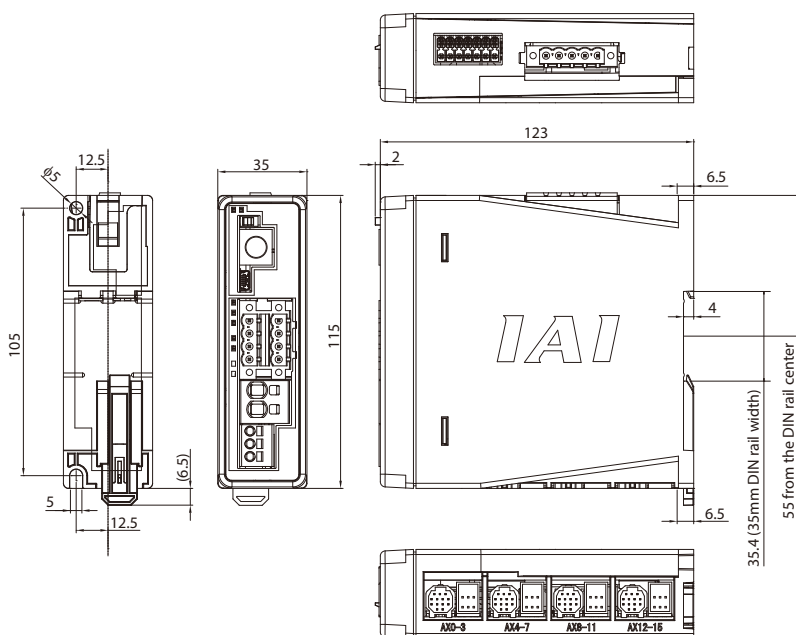

Specification	Description
Number of controlled axes	16 axes max. (4 axes with a single gateway unit)* ¹
Power supply voltage	24VDC±10%
Control power capacity	0.6A (0.3A with a single gateway unit + field bus module 0.3A)
Motor power capacity	51.2A max. from connected axes
Cooling method	Natural air cooling
Emergency stop input	B contact input
Enable input	None
T.P. enable input	Yes
Enable operation	Servo OFF
Backup memory	FRAM (256kbit), No. of overwrites: Unlimited
Calendar function	Yes (retains data for 10 days after power off)
Gateway board LED display	SYS LED × 1 (RUN/ALM), EMG LED × 1, MODE LED × 1 (AUTO/MANU), T.ERR LED × 1, C.ERR LED × 1 Field bus module status LED × 2
Tool connection	T/P connector: RS485 1ch (Modbus protocol compliant) USB connector: USB 1ch
Electromagnetic braking forced release mechanism	System I/O connector: External brake release signal input (24VDC) *Only used when an RCP6S unit is directly connected to the gateway unit. Disabled when a hub is connected.
Electric shock protection mechanism	Class 1, basic insulation
Insulation withstanding voltage	500VDC 10MΩ
Weight	250g
External dimensions	35W × 115H × 123D
Overseas Accreditations	CE, cUL (Both Acquired)

*¹ See P.273

Foreword

Slider Type

Wide Slider Type

Rod Type

Radial Cylinder

Wide Radial Cylinder

Table Type

Cleanroom Slider

Cleanroom Wide Slider

Dust/Splash-Proof Rod

Dust/Splash-Proof Radial Cylinder *

Dust/Splash-Proof Wide Radial Cylinder

Options

Reference Data

Controller

Hub Unit (RCM-P6HUB)

The hub unit cannot be used alone.
It must be used with a gateway unit.

Features:

The connection between gateway unit - hub unit and hub unit - RCP6S can be established using serial communication. By using a gateway unit with hub units, up to 16 axes can be controlled.

* The number of connectable axes will vary depending on the type of field networks and its mode. Please see P. 273 for the details.

Model Configuration

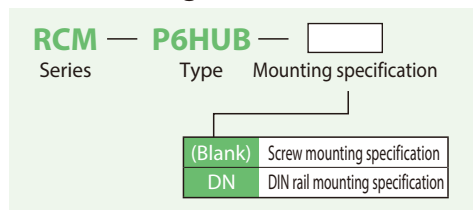

Specification

Specification	Description
Number of controlled axes	4 axes max.
Power supply voltage	24VDC±10%
Control power capacity	0.3A (single hub unit)
Motor power capacity	12.8A max. from connected axes
Emergency stop input	None
Enable input	None
LED display	SYS LED × 1 (RUN/ALM) AXIS LED × 4 (RUN/ALM)
Electromagnetic braking forced release mechanism	External brake release switch × 4
Electric shock protection mechanism	Class 1, basic insulation
Insulation withstanding voltage	500VDC 10MΩ
Contamination	Contamination 2
Weight	80g
External dimensions	35W × 115H × 45D
Overseas Accreditations	CE, cUL (Both Acquired)

External Dimensions

[Screw mounting specification]

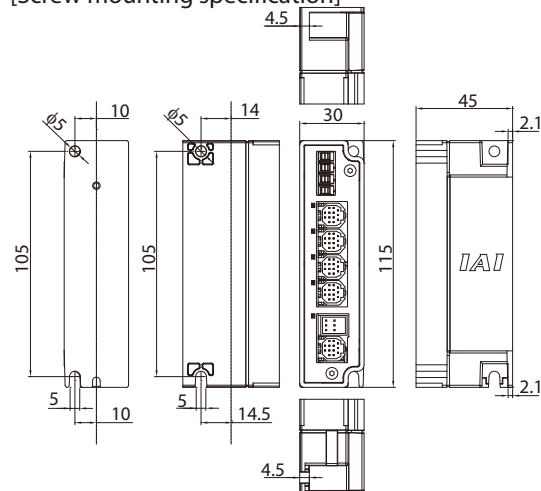

[DIN rail specification]

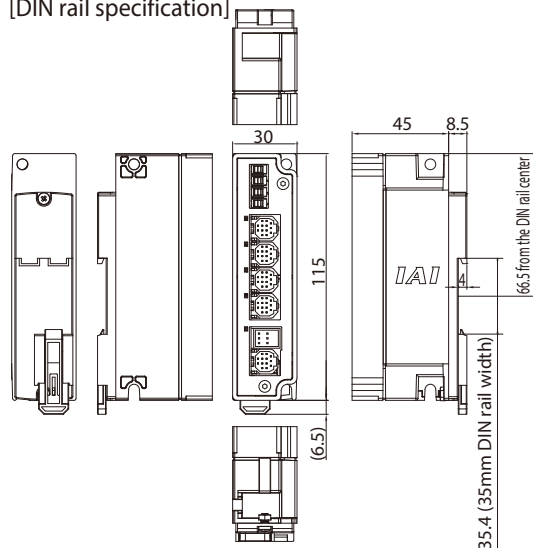

PLC Connection Unit (RCB-P6PLC)

■ Features

This is a terminal block used to connect the RCP6S and the PLC using serial communication. The RCP6S and the PLC connection unit can be easily connected with a cable.

* Cannot be connected to the gateway unit, hub unit or RCP6S gateway controller.



■ Model Configuration

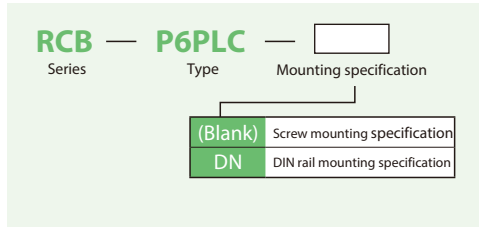

■ Connection Image

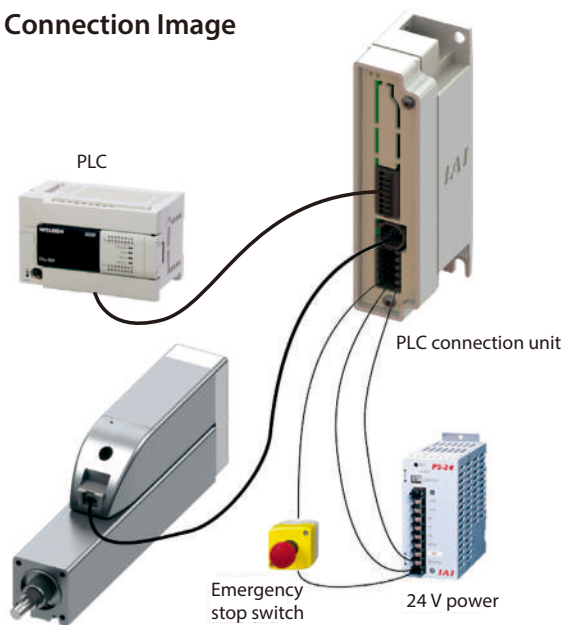

■ Specifications

Specified	Description
Number of controlled axes	1-axis
Power supply voltage	24VDC \pm 10%
Control power capacity	0A for single PLC connection unit 0.3A for connected PLC units + RCP6S built-in driver • For brake types, 0.7A for 0.2 sec is required for releasing brake
Motor power capacity	Depending on RCP6S built-in driver
Emergency stop input	B contact input
Enable input	None
LED display	None
Electromagnetic braking forced release mechanism	External brake release signal input (24VDC)
Electric shock protection mechanism	Class 1, basic insulation
Insulation withstanding voltage	500VDC 10M Ω
Contamination	Contamination 2
Weight	65g
External dimensions	35W \times 115H \times 45D
Overseas Accreditations	CE, cUL (Both Acquired)

■ External Dimensions

[Screw Mounting Spec.]

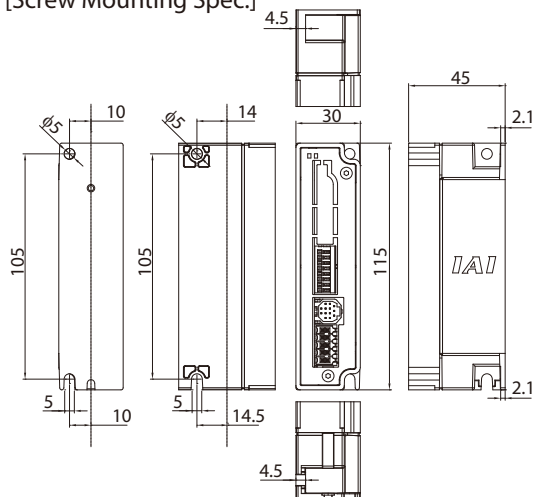

[DIN Rail Mounting Spec.]

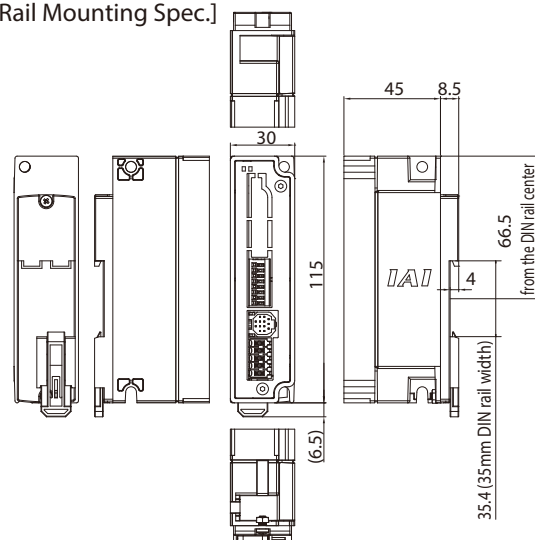

RCP6S Gateway Controller <RCM-P6□C>

■ Features

Actuators other than RCP6S can be driven by connecting to the RCP6S gateway unit and hub unit.

Details:

- RCP2~6, RCA, RCA2, RCD actuators can be connected.
- * Some products may not be supported
- RCP2~4, RCA, and RCA2 connections require a converter unit.
- The same control as an RCP6S built-in controller is possible.
(Refer to P.274 for details about control operation modes.)
- The actuator and controller information during operation can be displayed to a PC screen as a wave form through the use of PC software.

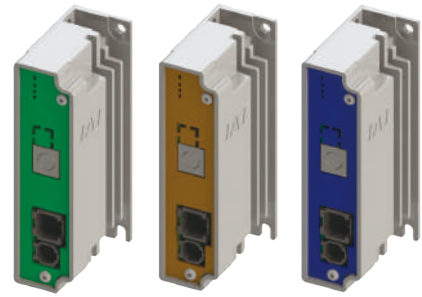

RCM-P6PC

RCM-P6DC

RCM-P6AC

RCM-CV-APCS
(Converter unit)

■ Model Configuration

RCM Series — Type — Motor Type — Encoder Type — Options — I/O Type — I/O Cable Length — Input Power — Mounting Specifications

Type	Motor Type	Encoder Type	Options	I/O Type	I/O Cable Length	Input Power	Mounting Specifications
P6PC Stepper motor				SE SIO specifications		0 24VDC	
P6AC Servo motor			HA High acceleration/deceleration specifications*1 LA Energy saving compatible*1		0 No cable		
P6DC Brush-less DC motor type				WAI Battery-less Absolute/Incremental I Incremental specification*2			Blank Screw mounting specification DN DIN rail mounting specification

*1: RCA series dedicated

Stepper motor	Servo motor	Brush-less DC motor type
20P 20□	2 2W	3D 3W
20SP 20□	5 5W	
28P 28□	5S 5W	
28SP 28□	10 10W	
35P 35□	20 20W	
42P 42□	20S 20W	
42SP 42□	30 30W	
56P 56□		

Notes

In principle, the same type of motor as the type of motor of the actuator to be connected should be entered, but there are some models where the motor type of some controllers and actuators do not match. Be sure to check the corresponding models listed below during selection.

<20SP/28SP/42SP/5S/20S Target Actuators>

- Motor Type [20SP]: RCP3-RA2AC, RCP3-RA2BC
- Motor Type [28SP]: RCP2-RA3C
- Motor Type [42SP]: RCP4-RA5C
- Motor Type [5S]: RCA2-SA2A□, RCA2-RA2A□
- Motor Type [20S]: RCA2-SA4□, RCA-RA3□, RCA2-TA5□, RCA-RG□3□, RCAW-RA3□

* Please contact IAI if you require a simple absolute encoder specification type.
* DC brush-less motors do not support simple absolute encoders.
* Refer to P.283 for converter unit and cable models.

Specifications

Specified Items	Specification Content		
Model number	RCM-P6PC	RCM-P6AC	RCM-P6DC
Number of controlled axes	1-axis		
Controller power	24VDC ± 10%		
Control power capacity	0.3A · For RCP6 types with brakes only, 0.7A for 0.2 sec is required for releasing brake	0.3A	
Motor power capacity	External 24V 28□ (for RCP2-RA3C), 35□, 42□, 56□ · When using the PowerCON, power consumption is 3.2A, peaking at 4.2A · When not using the PowerCON, power consumption is 1.7A 20□, 28□ Power consumption is 1.0A	<RCA2/RCA> (Parentheses indicate saving energy) · 10W/20W Rated 1.3A, Max. 4.4A (Max. 2.5A) · 20W (20S) Rated 1.7A, Max. 5.1A (Max. 3.4A) · 30W Rated 1.3A, Max. 4.0A (Max. 2.2A)	0.7A Rated, 1.5A Max.
Inrush current	8.3A	10A	
Emergency stop input	B contact input		
Enable input	None		
T.P. enable input	Yes		
Enable operation	Servo OFF		
Backup memory	FRAM (256kbit), No. of overwrites: Unlimited		
Calendar function	None (unless connected to a GW unit)		
Cooling method	Natural air cooling		
Supported encoders	· High-resolution battery-less absolute encoder: 8192 pulses/rev · Battery-less absolute encoder: 800 pulses/rev · Incremental encoder: 800 pulses/rev	· Battery-less absolute encoder: 16,384 pulses/rev · Other than for incremental specification RCA, RCA2-***N: 800 pulses/rev, RCA2-***N, RCA2-***NA: 1,048 pulses/rev	· Incremental encoder: 480 pulses/rev
LED display	SV/ALM LED×1		
Electromagnetic forced brake release mechanism	Brake release input (inside I/F connector)		
Electric shock protection mechanism	Class 1 basic insulation		
Insulation withstanding voltage	500VDC 10MΩ		
Contamination	Contamination 2		
Weight	Screw mounting specification: 200g, DIN rail mounting specification: 215g		
External dimensions	Screw mounting specification: 30W x 115H x 58D, DIN rail mounting specification: 30W x 115H x 66.5D		
Overseas accreditations	CE, cUL (Both Acquired)		

Touch panel teaching pendant

- **Features** A teaching device equipped with functions such as position teaching, trial operation, and monitoring.
- **Model** **TB-02-**
- **Configuration**

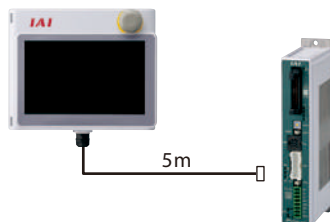

Specifications

Rated voltage	24VDC
Power consumption	3.6W or less (150mA or less)
Ambient operating temperature	0 to 40°C
Ambient operating humidity	20~85% RH (Non-condensing)
Environmental resistance	IP20
Mass	470g (TB-02 unit only)

PC compatible software (Windows only)

- **Features** The start-up support software which comes equipped with functions such as position teaching, trial operation, and monitoring. A complete range of functions needed for making adjustments contributes to a reduced start-up time.

Supported Windows versions: 7/8/10

- **Model** **RCM-101-MW** (with an external device communication cable + RS232 conversion unit)

Please contact IAI for the current supported versions.

- **Configuration**

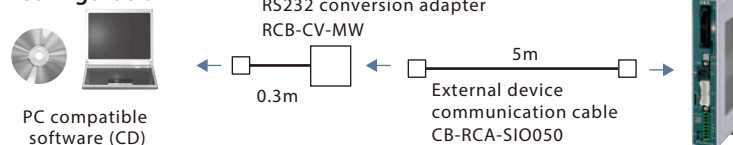

- **Model** **RCM-101-USB** (with an external device communication cable + USB conversion adapter + USB cable)

Please contact IAI for the current supported versions.

- **Configuration**

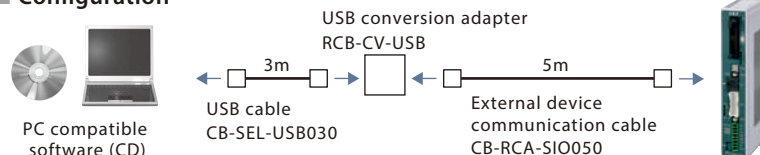

Maintenance Parts

When placing an order for the replacement cable, please use the model name shown below.

*There are restrictions on the total cable length.
Please check with the [Notes] on P. 271 and 280.

Cable Compatibility Chart

Connection destination		Gateway unit	Hub unit	PLC connection unit
RCP6S RCP6SCR RCP6SW	Standard cable		CB-RCP6S-PWBIO□□□	
	Robot cable		CB-RCP6S-PWBIO□□□-RB	
	<Extension> Standard cable		CB-RCP6S-PWBIO□□□-JY1	
	<Extension> Robot cable		CB-RCP6S-PWBIO□□□-JY1-RB	
Connection destination		Hub unit		
Gateway unit	Standard cable		CB-RCP6S-RLY□□□	
	Robot cable		CB-RCP6S-RLY□□□-RB	
	<Extension> Standard cable		CB-RCP6S-RLY□□□-JY1	
	<Extension> Robot cable		CB-RCP6S-RLY□□□-JY1-RB	
Connection destination		Converter unit	Actuator connecting to RCM-P6□C	
RCM-P6□C	Standard cable		CB-ADPC-MPA□□□	
	Robot cable		CB-ADPC-MPA□□□-RB	

Model number **CB-RCP6S-PWBIO** [] [] [] / **CB-RCP6S-PWBIO** [] [] [] -**RB**
 Standard cable Robot cable

* Please indicate the cable length (L) in [] [] [], maximum 20m, e.g.) 080 = 8m

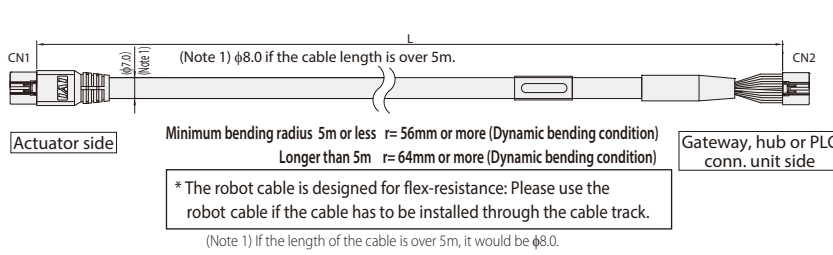

CN1			CN2		
Color	Signal name	Pin No.	Pin No.	Signal name	Color
Gray (AWG2219)	CP	1	1	CP	Gray (AWG2219)
Blue (AWG2219)	MP	8	8	MP	Blue (AWG2219)
Orange (AWG2219)	MP	9	9	MP	Orange (AWG2219)
Green (AWG2219)	GND	10	10	GND	Green (AWG2219)
Brown (AWG2219)	GND	11	11	GND	Brown (AWG2219)
Orange (AWG26)	AM SD+	6	6	AM SD+	Orange (AWG26)
Light blue (AWG26)	AM SD-	2	2	AM SD-	Light blue (AWG26)
Red (AWG26)	CT SD+	7	7	CT SD+	Red (AWG26)
Gray (AWG26)	CT SD-	3	3	CT SD-	Gray (AWG26)
Green (AWG26)	BK	4	4	BK	Green (AWG26)
Brown (AWG26)	EMGS	5	5	EMGS	Brown (AWG26)
-	NC	13	13	NC	-
Black (AWG26)	FG	12	12	FG	Black (AWG26)

Model number **CB-RCP6S-RLY** [] [] [] / **CB-RCP6S-RLY** [] [] [] -**RB**
 Standard cable Robot cable

* Please indicate the cable length (L) in [] [] [], maximum 10m, e.g.) 030 = 3m
 Available lengths: 1m/3m/5m/10m

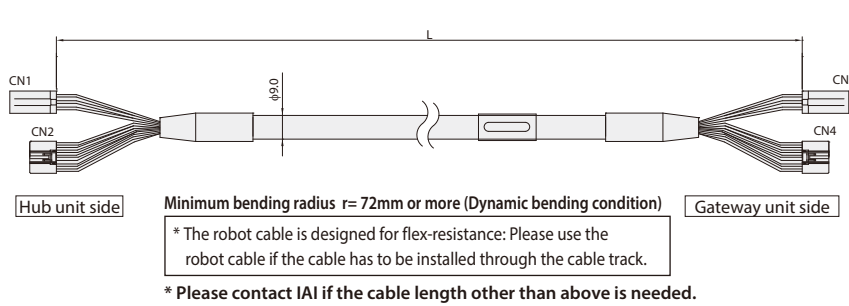

CN1			CN3		
Color	Signal name	Pin No.	Pin No.	Signal name	Color
Brown (AWG18)	MP	B1	B1	MP	Brown (AWG18)
Gray (AWG18)	MP	B2	B2	MP	Gray (AWG18)
Red (AWG18)	MP	B3	B3	MP	Red (AWG18)
Blue (AWG18)	GND	A1	A1	GND	Blue (AWG18)
Orange (AWG18)	GND	A2	A2	GND	Orange (AWG18)
Green (AWG18)	GND	A3	A3	GND	Green (AWG18)

CN2			CN4		
Color	Signal name	Pin No.	Pin No.	Signal name	Color
Blue (AWG22)	CP	1	1	CP	Blue (AWG22)
-	NC	8	8	NC	-
-	NC	9	9	NC	-
Orange (AWG22)	GND	10	10	GND	Orange (AWG22)
Green (AWG22)	GND	11	11	GND	Green (AWG22)
Brown (AWG26)	AM SD+	6	6	AM SD+	Brown (AWG26)
Green (AWG26)	AM SD-	2	2	AM SD-	Green (AWG26)
Red (AWG26)	CT SD+	7	7	CT SD+	Red (AWG26)
Gray (AWG26)	CT SD-	3	3	CT SD-	Gray (AWG26)
Light blue (AWG26)	NC	4	4	NC	Light blue (AWG26)
Orange (AWG26)	EMGS	5	5	EMGS	Orange (AWG26)
-	NC	13	13	NC	-
Black (AWG26)	FG	12	12	FG	Black (AWG26)

Model number **CB-RCP6S-PWBIO** [] [] [] -**JY1** / **CB-RCP6S-PWBIO** [] [] [] -**JY1-RB**
 Standard cable Robot cable

* Please indicate the cable length (L) in [] [] [], maximum 5m, e.g.) 030 = 3m
 Available lengths: 1m/3m/5mm

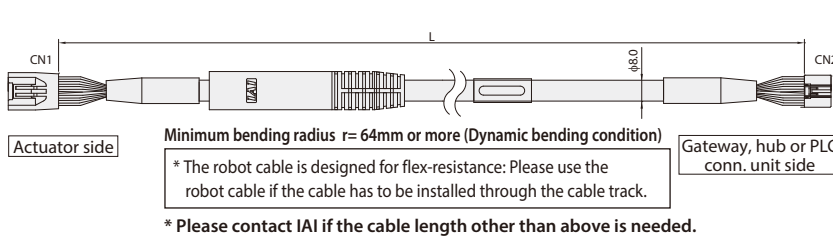

CN1			CN2		
Color	Signal name	Pin No.	Pin No.	Signal name	Color
Gray (AWG18)	CP	1	1	CP	Gray (AWG18)
Blue (AWG18)	MP	8	8	MP	Blue (AWG18)
Orange (AWG18)	MP	9	9	MP	Orange (AWG18)
Green (AWG18)	GND	10	10	GND	Green (AWG18)
Brown (AWG18)	GND	11	11	GND	Brown (AWG18)
Orange (AWG26)	AM SD+	6	6	AM SD+	Orange (AWG26)
Light blue (AWG26)	AM SD-	2	2	AM SD-	Light blue (AWG26)
Red (AWG26)	CT SD+	7	7	CT SD+	Red (AWG26)
Gray (AWG26)	CT SD-	3	3	CT SD-	Gray (AWG26)
Light blue (AWG26)	NC	4	4	NC	Light blue (AWG26)
Orange (AWG26)	EMGS	5	5	EMGS	Orange (AWG26)
-	NC	13	13	NC	-
Black (AWG26)	FG	12	12	FG	Black (AWG26)

Model number **CB-RCP6S-RLY** [] [] [] -**JY1** / **CB-RCP6S-RLY** [] [] [] -**JY1-RB**
 Standard cable Robot cable

* Please indicate the cable length (L) in [] [] [], maximum 5m, e.g.) 030 = 3m
 Available lengths: 1m/3m/5mm

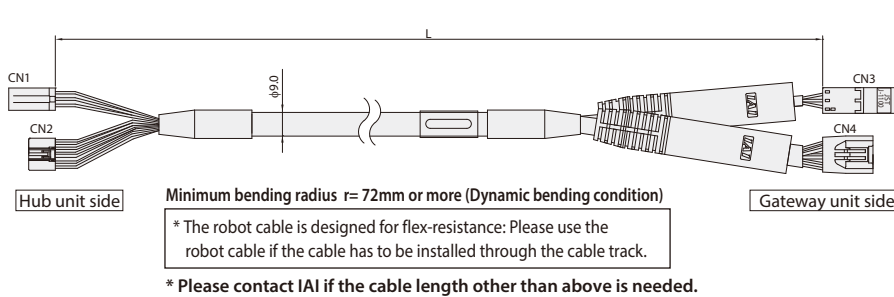

CN1			CN3		
Color	Signal name	Pin No.	Pin No.	Signal name	Color
Brown (AWG18)	MP	B1	B1	MP	Brown (AWG18)
Gray (AWG18)	MP	B2	B2	MP	Gray (AWG18)
Red (AWG18)	MP	B3	B3	MP	Red (AWG18)
Blue (AWG18)	GND	A1	A1	GND	Blue (AWG18)
Orange (AWG18)	GND	A2	A2	GND	Orange (AWG18)
Green (AWG18)	GND	A3	A3	GND	Green (AWG18)

CN2			CN4		
Color	Signal name	Pin No.	Pin No.	Signal name	Color
Blue (AWG22)	CP	1	1	CP	Blue (AWG22)
-	NC	8	8	NC	-
-	NC	9	9	NC	-
Orange (AWG22)	GND	10	10	GND	Orange (AWG22)
Green (AWG22)	GND	11	11	GND	Green (AWG22)
Brown (AWG26)	AM SD+	6	6	AM SD+	Brown (AWG26)
Green (AWG26)	AM SD-	2	2	AM SD-	Green (AWG26)
Red (AWG26)	CT SD+	7	7	CT SD+	Red (AWG26)
Gray (AWG26)	CT SD-	3	3	CT SD-	Gray (AWG26)
Light blue (AWG26)	NC	4	4	NC	Light blue (AWG26)
Orange (AWG26)	EMGS	5	5	EMGS	Orange (AWG26)
-	NC	13	13	NC	-
Black (AWG26)	FG	12	12	FG	Black (AWG26)

Model Number **CB-ADPC-MPA** [] [] [] / **CB-ADPC-MPA** [] [] [] -**RB**
 Standard cable Robot cable

* Please indicate the cable length (L) in [] [] [], e.g.) 030 = 3m

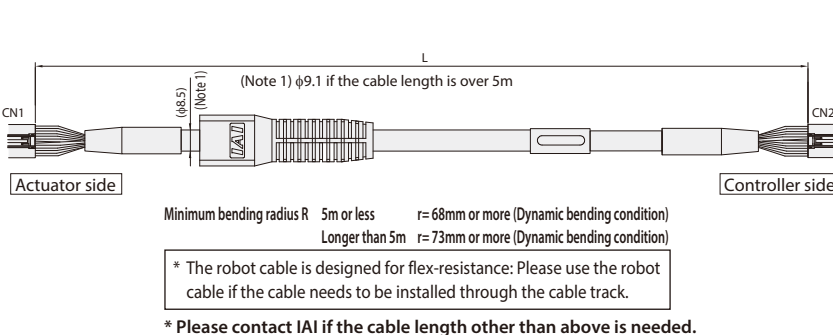

CN1			CN2		
Color	Signal name	Pin	Pin	Signal name	Color
Blue (AWG2219)	U	3	3	U	Blue (AWG2219)
Orange (AWG2219)	V	5	5	V	Orange (AWG2219)
Brown (AWG2219)	-	10	10	φB	Brown (AWG2219)
Gray (AWG2219)	-	9	9	VMM	Gray (AWG2219)
Green (AWG2219)	W	4	4	W	Green (AWG2219)
Red (AWG2219)	B+	15	15	B+	Red (AWG2219)
Black (AWG26)	-	8	8	LS+	Black (AWG26)
Yellow (AWG26)	-	14	14	LS-	Yellow (AWG26)
Blue (AWG26)	A+	12	12	A+	Blue (AWG26)
Orange (AWG26)	A-	17	17	A-	Orange (AWG26)
Green (AWG26)	B+	11	11	B+	Green (AWG26)
Brown (AWG26)	B-	6	6	B-	Brown (AWG26)
Gray (AWG26)	H51 IN	11	11	H51 IN	Gray (AWG26)
Blue (AWG26)	H52 IN	16	16	H52 IN	Blue (AWG26)
Blue (AWG26)	-	20	20	BK+	Blue (AWG26)
Red (AWG26)	-	2	2	LS-	Red (AWG26)
Gray (AWG26)	VCC	21	21	VCC	Gray (AWG26)
Red (AWG26)	GND	7	7	GND	Red (AWG26)
Brown (AWG26)	VPSBAT	18	18	VPS	Brown (AWG26)
Green (AWG26)	H53 IN	13	13	LS GND	Green (AWG26)
-	-	19	19	-	-
Pink (AWG26)	BAT+	22	22	VCC	Pink (AWG26)
-	-	23	23	-	-
Black (AWG26)	FG	24	24	FG	Black (AWG26)

Foreword
 Slider Type
 Wide Slider Type
 Rod Type
 Radial Cylinder
 Wide Radial Cylinder
 Table Type
 Cleanroom Slider
 Cleanroom Wide Slider
 Dust/Splash-Proof Rod
 Dust/Splash-Proof Radial Cylinder
 Dust/Splash-Proof Wide Radial Cylinder
 Options
 Reference Data
 Controller

IAI America, Inc.

Headquarters: 2690 W. 237th Street, Torrance, CA 90505 (800) 736-1712

Chicago Office: 110 E. State Pkwy, Schaumburg, IL 60173 (800) 944-0333

Atlanta Office: 1220 Kennestone Circle, Suite 108, Marietta, GA 30066 (888) 354-9470

www.intelligentactuator.com

The information contained in this product brochure may change without prior notice due to product improvements. Please contact IAI for latest information.

IAI Industrieroboter GmbH

Ober der Röth 4, D-65824 Schwalbach am Taunus, Germany

IAI (Shanghai) Co., Ltd.

Shanghai Jiahua Business Center A8-303, 808,
Hongqiao Rd., Shanghai 200030, China

IAI Robot (Thailand) Co., Ltd.

825 Phairojkijja Tower 12th Floor, Bangna-Trad RD.,
Bangna, Bangna, Bangkok 10260, Thailand